

Crash-Tested Bridge Railings for Timber Bridges

Michael A. Ritter, *Forest Service, U.S. Department of Agriculture*

Ronald K. Faller, *University of Nebraska-Lincoln*

Sheila R. Duwadi, *Federal Highway Administration*

Bridge railing systems in the United States historically have been designed on the basis of static load criteria given in the AASHTO *Standard Specifications for Highway Bridges*. In the past decade, full-scale vehicle crash testing has been recognized as a more appropriate and reliable method of evaluating bridge railing acceptability. In 1989 AASHTO published *Guide Specifications for Bridge Railings*, which gives the recommendations and procedures to evaluate bridge railings by full-scale vehicle crash testing. In 1993 NCHRP published *Report 350: Recommended Procedures for the Safety Performance Evaluation of Highway Features*, which provides criteria for evaluating longitudinal barriers. From these specifications, a cooperative research program was initiated to develop and crash test several bridge railings for longitudinal wood decks. The research resulted in the successful development and testing of five bridge railing systems for longitudinally laminated wood bridge decks in accordance with the AASHTO Performance Level 1 and Performance Level 2 requirements and the Test Level 4 requirements of *NCHRP Report 350*.

The primary purpose of a bridge railing is to safely contain vehicles that cross the bridge. To meet this objective, railings must be designed to withstand the force of vehicle impact.

In designing railing systems for highway bridges, engineers traditionally have assumed that vehicle impact forces can be approximated by equivalent static loads that are applied to railing elements. Although railing loads are actually dynamic, the equivalent-static-load method has been used for many years as a simplified approach to standardized railing design. Currently, the AASHTO *Standard Specifications for Highway Bridges* (1) requires that rail posts be designed to resist an outward transverse static load of 44.5 kN (10,000 lb). A portion of this load is also applied to posts in the inward transverse, longitudinal, and vertical directions and to the rail elements. These requirements are identical for all bridges regardless of bridge geometry or traffic conditions. Thus, a railing for a single-lane bridge on a low-volume road must meet the same loading requirements as a railing for a bridge on a major highway.

Despite the widespread use of design requirements based primarily on static load criteria, the need for more appropriate criteria for full-scale vehicle crash tests has long been recognized. The first U.S. guidelines for full-scale vehicle crash testing were published in 1962 (2) in a one-page document that provided basic guidelines for the test vehicle mass, approach speed, and impact angle and provided a degree of uniformity to the traffic barrier research in progress at the time.

Through subsequent use of this document, the need for additional comprehensive guidelines became apparent, and several reports were published during the 1970s through NCHRP. In 1981 NCHRP released *NCHRP Report 230: Recommended Procedures for the Safety Performance Evaluation of Highway Appurtenances* (3). This comprehensive report has been the primary source of crash testing criteria for more than a decade and continues to serve as the basis for current bridge railing testing requirements.

Although crash test criteria have been available for many years, the requirement to implement crash testing as a means of evaluating bridge railings in the United States depended on the jurisdiction. Some states implemented extensive bridge railing crash testing programs, whereas others continued to use static load design exclusively. The first recognition of full-scale crash testing in a national bridge specification came in 1989, when AASHTO published the *Guide Specifications for Bridge Railings* (or AASHTO Guide Specifications) (4). This work presents recommendations for the development, testing, and use of crash-tested bridge railings and refers extensively to NCHRP 230 for crash testing procedures and requirements.

A primary concept of the AASHTO Guide Specifications is that bridge railing performance needs differ greatly from site to site and that railing designs and costs should match site needs. Thus, recommended requirements for railing testing are based on three performance levels: Performance Level 1 (PL-1), PL-2, and PL-3. The PL-1 requirements represent the weakest system, and the PL-3 the strongest system. The relationship between the railing performance level and requirements for a specific bridge depend on a number of factors, such as the type of roadway, design speed, average daily traffic, and percentage of trucks in the traffic mix. The recently published *NCHRP Report 350: Recommended Procedures for the Safety Performance Evaluation of Highway Features* (5) provides for six test levels to evaluate longitudinal barriers: Test Level 1 (TL-1) through TL-6. Although this document does not include objective criteria for relating a test level to a specific roadway type, the lower test levels generally are intended for use on roadways with lower service levels and certain types of work zones, whereas the higher test levels are intended for use on higher-service-level roadways. Most highways on which wood bridges are installed will require railings that meet either the AASHTO PL-1 or PL-2 requirements or the NCHRP 350 TL-1 through TL-4 requirements. A railing that meets either PL-3, TL-5, or TL-6 requirements currently has a very limited application for wood bridges because of the high traffic volume and speeds associated with these levels.

The AASHTO Guide Specifications are optional, and the use of static load design criteria is permitted. How-

ever, emphasis on the use of crash-tested railings for new federally funded projects has increased significantly the role of full-scale crash testing as a means of evaluating railing performance. It is anticipated that AASHTO will adopt the guide specifications in the future, making crash-tested railings mandatory for most bridges. FHWA has officially adopted *NCHRP Report 350* as a replacement for *NCHRP Report 230*. At this time, it is unclear if AASHTO will adopt the Report 350 criteria into its guide specifications or retain the current criteria based on Report 230.

As of August 1990, 25 bridge railings had been successfully crash tested in accordance with the requirements of the AASHTO Guide Specifications and approved for use on federal-aid projects by FHWA (6). Of these railings, 24 are for concrete bridge decks and 1 is for a wood deck. For wood bridges to compete with other bridges in the future, a range of crash-tested bridge railings for different wood bridge types will be required. Because of this need, national emphasis was placed on developing a limited number of crash-tested railings for wood bridges.

OBJECTIVE AND SCOPE

To meet the need for crashworthy railings for wood bridges, the Forest Products Laboratory, USDA Forest Service, in cooperation with the Midwest Roadside Safety Facility of the University of Nebraska at Lincoln, FHWA, and the wood products industry, initiated a program to develop crash-tested bridge railings for longitudinal wood decks. The program objectives were to develop five crashworthy railings: three to meet AASHTO PL-1, one to meet AASHTO PL-2, and one to meet *NCHRP Report 350* TL-4. The scope of the project was limited to railings for longitudinal wood decks, 252 mm (10 in.) or greater in thickness, and constructed of glued-laminated (glulam) timber, spike-laminated lumber, or stress-laminated lumber. In each system, the lumber laminations are placed edgewise and oriented with the lumber length parallel to the direction of traffic. A brief description of each longitudinal deck bridge type is provided in *Timber Bridges: Design, Construction, Inspection, and Maintenance* (7).

Longitudinal glulam timber decks are constructed of panels that consist of individual lumber laminations glued together with waterproof structural adhesives. The panels are 1.07 to 1.38 m (3.5 to 4.5 ft) wide and effectively function as a large, solid block of wood. To form the bridge deck, panels are placed side by side and interconnected by transverse distributor beams bolted to the deck underside at intervals of 2.4 m (8 ft) or less. These distributor beams are designed to transfer vertical

loads between adjacent panels. They are not designed to resist lateral loads.

Spike-laminated decks are constructed of sawn lumber laminations 102 mm (4 in.) in nominal thickness. The individual laminations are interconnected with spikes that are typically 8 or 9.5 mm ($5/16$ or $3/8$ in.) in diameter and 356 to 406 mm (14 to 16 in.) long. The decks are commonly manufactured in panels that are 1.5 to 2.1 m (5 to 7 ft) wide and interconnected with transverse distributor beams in a manner similar to longitudinal glulam timber decks.

Stress-laminated decks are constructed of sawn lumber laminations that are typically 51 to 102 mm (2 to 4 in.) in nominal thickness. The laminations are stressed together with high-strength steel bars that are placed in holes drilled through the center of the wide faces of the laminations. When tensioned, the bars create compression between the laminations, and the entire deck effectively acts as a solid, orthotropic wood plate.

TEST REQUIREMENTS AND EVALUATION CRITERIA

Test requirements and evaluation criteria for this project followed procedures defined in the AASHTO Guide Specifications (including applicable references to *NCHRP Report 230*) and the *NCHRP Report 350* criteria. These procedures establish a uniform methodology for testing and evaluating railings so that the safety performance of different railing designs, tested and evaluated by different agencies, can be compared. It is impractical and impossible to test all railings for all possible vehicle and impact conditions. Therefore, the procedures specify a limited number of tests using severe vehicle impact conditions and a set of criteria against which test results may be evaluated.

Test Requirements

Vehicle impact requirements for railing crash testing depend on the railing performance or test level and are specified as requirements for vehicle type and weight, impact speed, and impact angle relative to the longitudinal railing axis. Testing for PL-1 requires two vehicle impact tests, and testing for PL-2 and TL-4 requires three vehicle impact tests. A summary of the requirements for PL-1, PL-2, and TL-4 is given in Table 1. In some cases, all tests for a given level may not be required if a railing with similar geometry and strength was tested previously and found to be satisfactory.

In addition to vehicle impact requirements, the AASHTO Guide Specifications and the *NCHRP Report 350* criteria also specify requirements for data acquisition and construction of the bridge railings. Require-

ments for data acquisition are referenced to Reports 230 and 350 and include specific data collection parameters and techniques that must be completed before, during, and after the crash test. Construction requirements specify that the bridge railing be designed, constructed, erected, and tested in a manner representative of actual installations. To assess properly the performance of most bridge railings, they must also be evaluated as a system in combination with the bridge superstructure for which it is intended. This is very important for railings for wood bridges, because the attachment of the railing to the bridge deck and the ability of the wood superstructure to resist applied railing loads may often be the controlling parameters.

Evaluation Criteria

Evaluation criteria for full-scale crash testing are based on three appraisal areas: structural adequacy, occupant risk, and vehicle trajectory after the collision. Criteria for structural adequacy are intended to evaluate the ability of the railing to contain, redirect, or permit controlled vehicle penetration in a predictable manner. Occupant risk evaluates the degree of hazard to occupants of the impacting vehicle. Vehicle trajectory after the collision is concerned with the path and final position of the impacting vehicle and the probable involvement of the impacting vehicle with other traffic. Note that these criteria address only the safety and dynamic performance of the railing and do not include service criteria such as aesthetics, economics, bridge damage, or post-impact maintenance requirements. The following evaluation criteria are summarized from the AASHTO Guide Specifications for PL-1 and PL-2 testing (similar evaluation criteria are provided in *NCHRP Report 350*):

1. The railing shall contain the vehicle; neither the vehicle nor its cargo shall penetrate or go over the installation. Controlled lateral deflection of the railing is acceptable.
2. Detached elements, fragments, or other debris from the railing shall not penetrate or show potential for penetrating the passenger compartment or present undue hazard to other traffic.
3. Integrity of the passenger compartment must be maintained with no intrusion and essentially no deformation.
4. The vehicle shall remain upright during and after collision.
5. The railing shall smoothly redirect the vehicle. A redirection is deemed smooth if the rear of the vehicle does not yaw more than 5 degrees away from the railing

from time of impact until the vehicle separates from the railing.

6. The smoothness of the vehicle-railing interaction is further assessed by the effective coefficient of friction μ , where $\mu = 0.0-0.25$ is good, $\mu = 0.26-0.35$ is fair, and $\mu \geq 0.36$ is marginal. Requirements for computing μ are given in the AASHTO Guide Specifications.

7. The impact velocity of a hypothetical front-seat passenger against the vehicle interior, calculated from vehicle accelerations and 610-mm (2-ft) longitudinal and 305-mm (1-ft) lateral displacements, shall be less than 9.15 m/sec (30 ft/sec) in the longitudinal direction and 7.63 m/sec (25 ft/sec) in the lateral direction. In addition, the highest 10-msec average vehicle accelerations subsequent to the instant of hypothetical passenger impact should be less than 147 m/sec² (483 ft/sec²) in the longitudinal and lateral directions.

8. Vehicle exit angle from the barrier shall not be more than 12 degrees. Within 30.5 m (100 ft) plus the length of the test vehicle from the point of initial impact with the railing, the railing side of the vehicle shall move no more than 6.1 m (20 ft) from the line of the traffic face of the railing.

DEVELOPMENT PHASE

Using a fundamental understanding of the performance characteristics of each deck type, development work was initiated to formulate a methodology for the railing tests. Because of economics and time, it was considered impractical to develop and test different railing systems for each longitudinal deck type. Instead, a more feasible approach was undertaken to develop several railing systems that could be adapted to each of the three longi-

tudinal deck types, without modifications that would result in reduced performance. To accomplish this, it was determined that railing development and testing should use the weakest deck type. This decision was based on the premise that if successful tests could be completed on the weakest deck, the railing could be adapted to stronger decks without hurting performance.

In assessing the potential resistance of each deck type to transverse railing impact forces, the strength of the wood and mechanical reinforcement was considered. Of primary concern was loading that could introduce tension perpendicular to grain stress in the wood deck.

Of the three deck types, the stress-laminated deck was considered the strongest for transverse railing loads, because the high-strength steel bars are continuous across the deck width. Loads developed at vehicle impact can be effectively distributed across the deck by the bars, making the entire deck width effective in resisting the applied loads.

The spike-laminated deck was considered to be of intermediate strength. If railing loads are applied transverse to the panel length, the loads are resisted by the spikes in withdrawal. Because of this, tension perpendicular to grain in the lumber laminations is not a concern; however, the spikes could be pulled from the deck, resulting in longitudinal separations between the laminations, and additional reinforcement would be required.

The glulam timber deck was considered to be the weakest in resisting railing loads, because the glulam timber panels act as solid pieces of wood, and loads applied transverse to the panel length are most likely to introduce tension perpendicular to grain and failure in the upper panel section. Mechanical reinforcement was considered necessary for longitudinal glulam timber

TABLE 1 Vehicle Impact Requirements for PL-1, PL-2, and TL-4 Bridge Railings

AASHTO Performance Level (4)	Impact Conditions		
	Small Car (816 kg)	Pickup Truck (2,449 kg)	Medium Single-Unit Truck (8,165 kg)
1	80.5 km/h 20 deg	72.4 km/h 20 deg	
2	96.6 km/h 20 deg	96.6 km/h 20 deg	80.5 km/h 15 deg
NCHRP 350 Test Level (5)	Impact Conditions		
	Small Car (820 kg)	Pickup Truck (2,000 kg)	Single-Unit Van Truck (8,000 kg)
4	100 km/h 20 deg	100 km/h 25 deg	80 km/h 15 deg

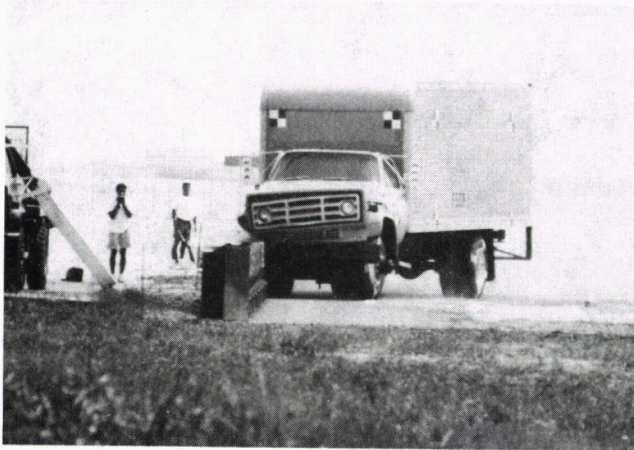

FIGURE 1 Crash-test sequence for 8172-kg (18,000-lb) truck traveling at 80.5 km/hr (50 mph), hitting railing at 15-degree angle to longitudinal railing axis.

decks to resist railing loads without damage. Thus, the glulam timber deck was considered the weakest deck for transverse railing loads and was selected for full-scale crash testing. If bridge railings performed acceptably on the glulam timber system, it was rationalized that the railings could be adapted to the other longitudinal wood bridge decks with no reduction in railing performance.

The primary emphasis of the railing design process was to develop railings that would meet the requirements for the AASHTO Guide Specifications and *NCHRP Report 350*. In addition, it was determined that consideration be given to (a) the extent of probable damage to the structure after vehicle impact and the difficulty and cost of required repairs; (b) adaptability of the railing to different wood deck types; (c) cost of the railing system to the user, including material, fabrication, and construction; (d) ease of railing construction and maintenance; and (e) aesthetics.

The conclusion of the development phase involved the design of several railing systems and preparation of plans and specifications for testing. The selection and design of these final systems were based on a review of other railings that had been crash tested successfully, as well as those that are used on wood bridges but had not been crash tested. To the extent possible, feasible designs were evaluated using computer simulation models. Although several proven computer models were used, it was difficult to adapt the programs for wood components because the behavior and properties of the wood systems at ultimate loading were unknown. Data collected during the crash testing were used to refine input parameters and more accurately predict railing performance in subsequent tests.

TEST METHODOLOGY

Testing of all bridge railings was completed at the Midwest Roadside Safety Facility in Lincoln, Nebraska. The site is located at an airport and was formerly a taxiway and parking area for military aircraft. It includes approximately 11 ha (27 acres) of concrete pavement and 1.6 ha (4 acres) of soil surface. To complete railing testing, a test bridge was constructed that measured approximately 2.4 m (8 ft) wide and 28.6 m (93.75 ft) long, in five simply supported spans measuring 5.72 m (18.75 ft) each. The deck was constructed of glulam timber panels 273 mm (10.75 in.) thick and 1.2 m (4 ft) wide. The glulam timber for the deck was Combination 2 Douglas fir given in the *AASHTO Standard Specifications for Highway Bridges (1)* and was treated with pentachlorophenol in heavy oil in accordance with American Wood Preservers' Association (AWPA) Standard C14 (8). Two glulam timber panels were placed

side by side to achieve the 2.4-m (8-ft) width, and transverse distributor beams were attached to the deck underside per AASHTO requirements (1). The test bridge was supported by concrete footings that were placed in excavations so that the top of the test bridge was level with the concrete surface at the site.

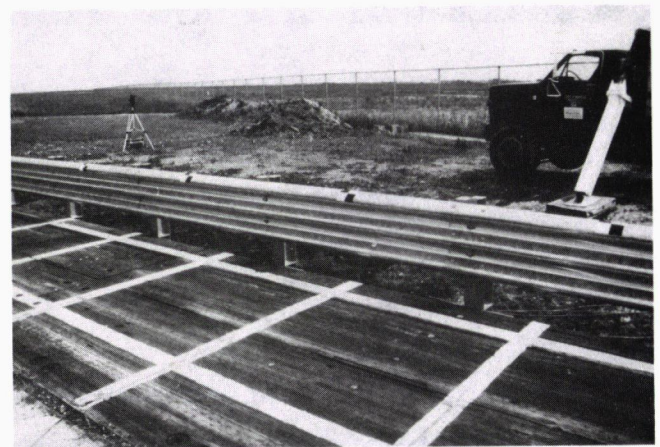
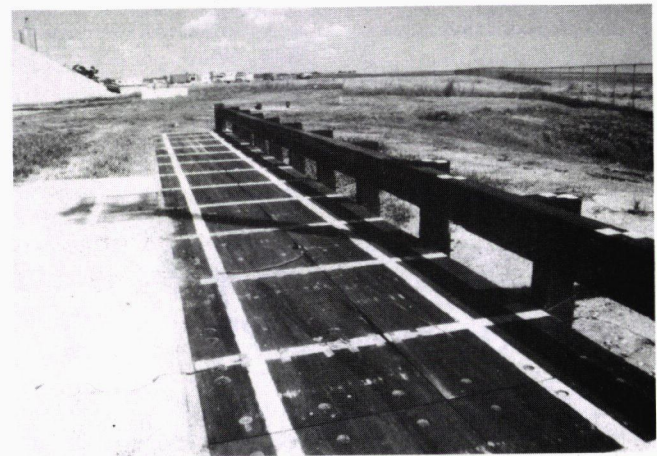
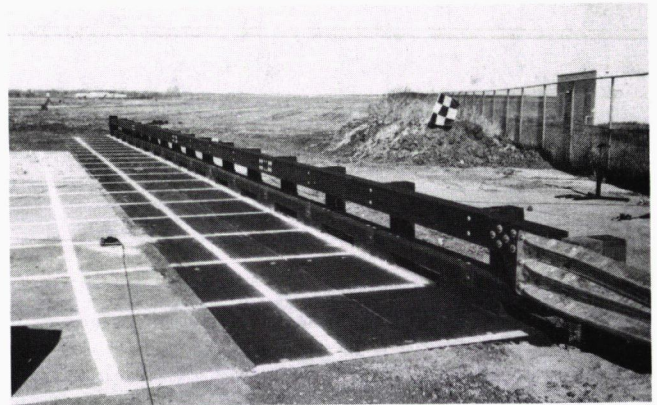

FIGURE 2 Bridge railings successfully crash tested to AASHTO PL-1 (photographs taken before testing).

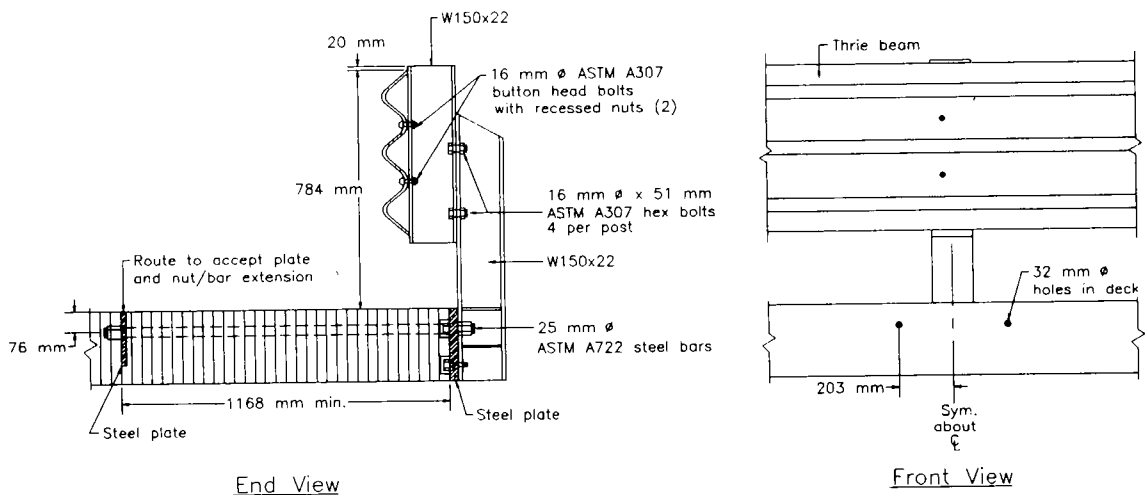
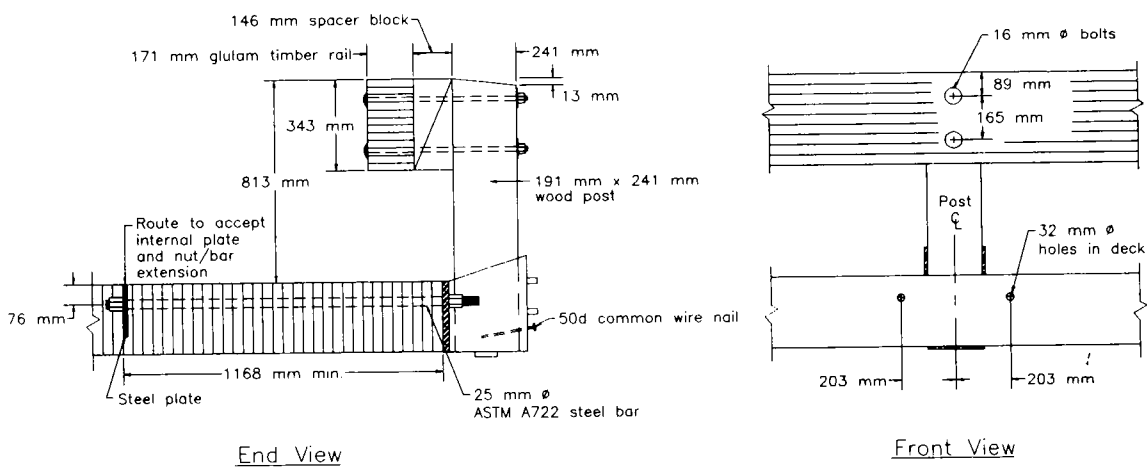
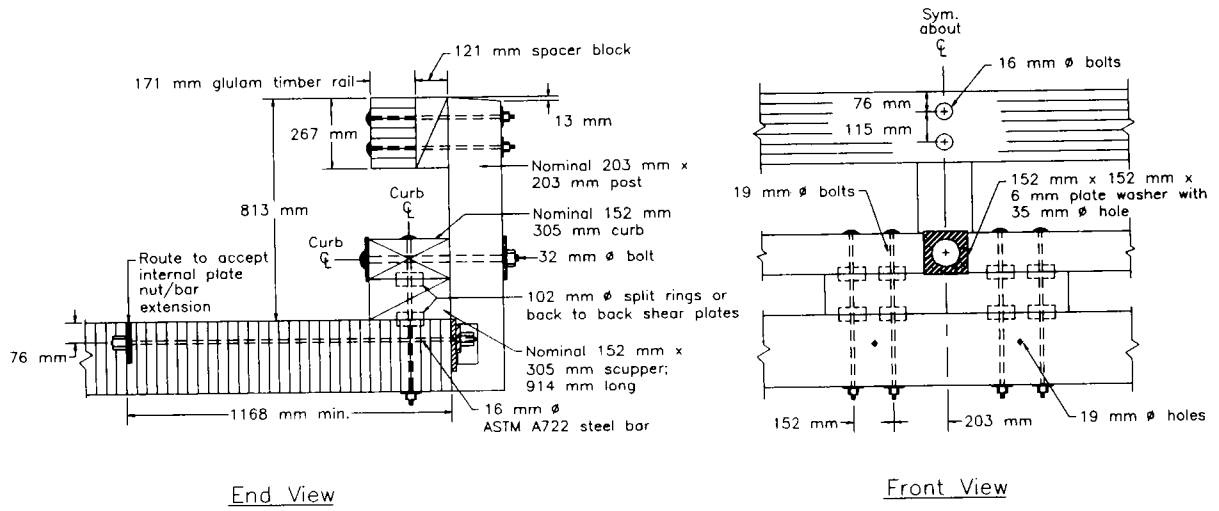

FIGURE 3 Drawings of bridge railings successfully crash tested to AASHTO PL-1: top, glulam timber rail with curb; middle, glulam timber rail without curb; bottom, steel rail.

Vehicle propulsion and guidance were provided by steel cable configurations. For propulsion, a reverse cable tow with a 1:2 mechanical advantage was used. A cable was attached to the front of the vehicle, routed through a series of pulleys, and connected to a tow vehicle that traveled in a direction opposite to the test vehicle. The unoccupied test vehicle was then pulled by the tow vehicle and released from the tow cable approximately 9.2 m (30 ft) before impact. A vehicle guidance system developed by Hinch was used to steer the test vehicle (9). Using this system, the left front wheel hub is attached to a tensioned steel cable that maintains the vehicle's direction along a designated straight path. Approximately 9.2 m (30 ft) from impact, the guidance connection is sheared off and the vehicle separates from the guidance cable. A crash-test sequence for an 8172-kg (18,000-lb) vehicle is shown in Figure 1.

Data acquisition parameters and techniques for the crash testing program were based on requirements of the AASHTO Guide Specifications and NCHRP Report 350 and followed three testing phases: pretest, test, and posttest. In the pretest phase, the as-built bridge railing and vehicle were documented using photography and drawings that indicated the applicable configuration, dimensions, and vehicle weight. During the test phase, data on the vehicle impact speed, impact angle, trajectory, and accelerations were collected primarily through the use of high-speed motion picture photography and accelerometers mounted on the vehicle. In the posttest phase, the condition of the railing, bridge superstructure, and vehicle were documented using photography and standardized damage assessment methods, including the traffic accident data scale (10) and vehicle damage index (11). Additional instrumentation was placed

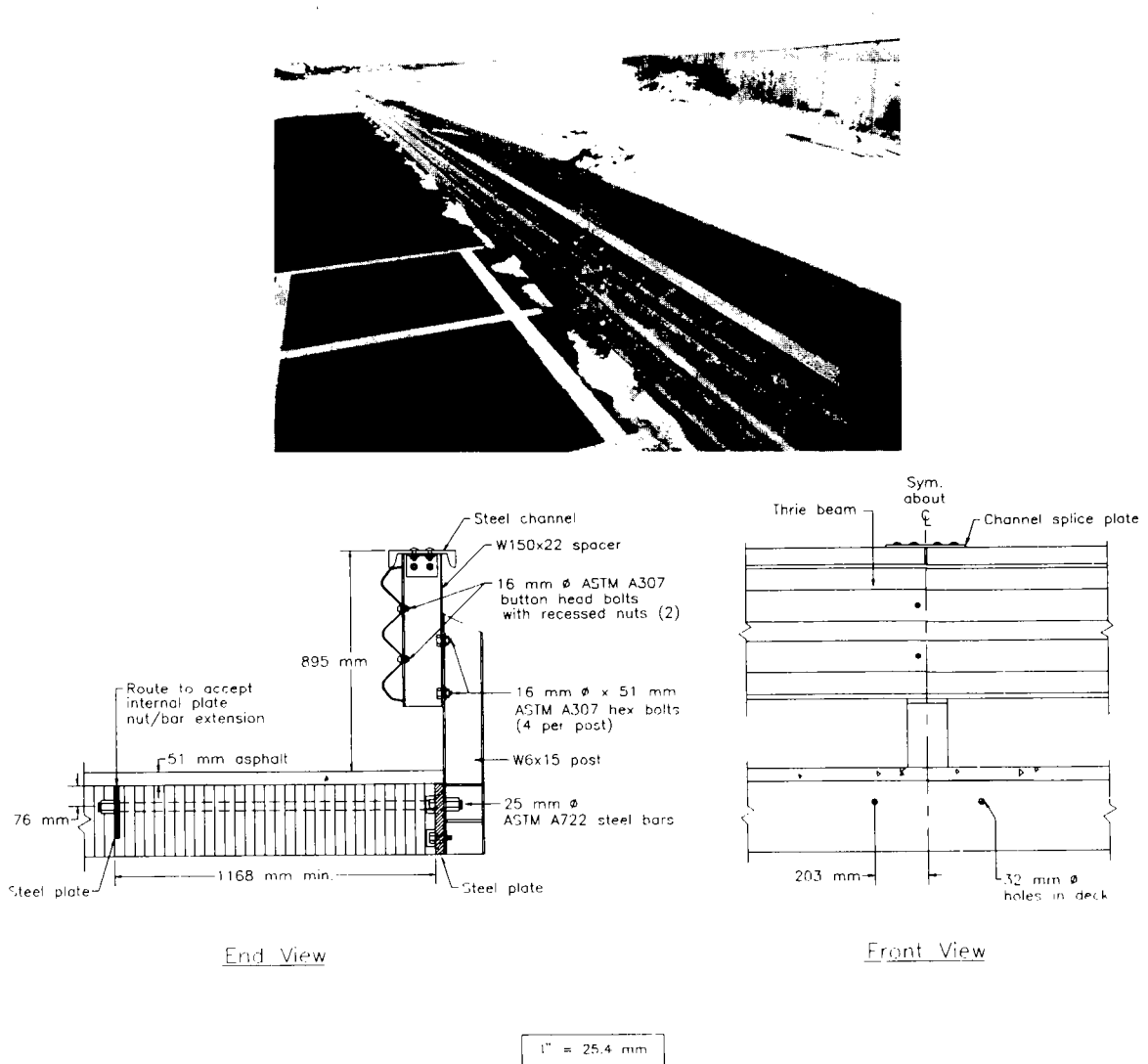

FIGURE 4 Steel thrie beam bridge railing successfully crash tested to AASHTO PL-2 (photograph taken before testing).

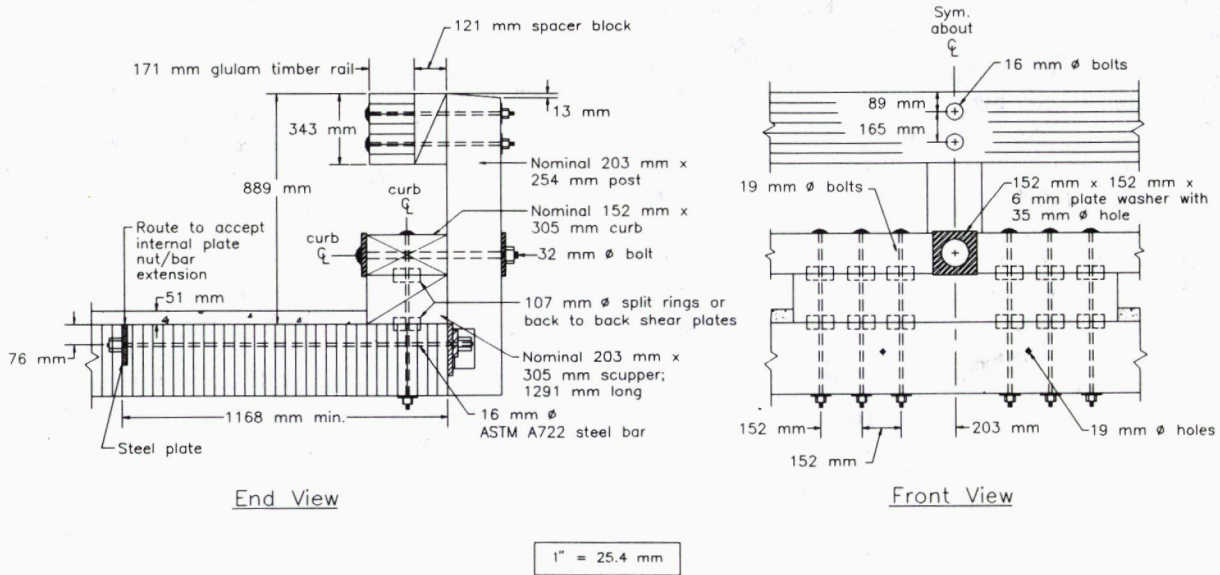
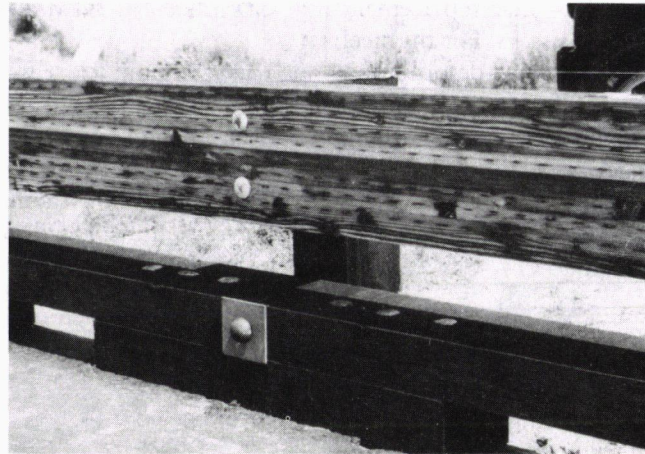

FIGURE 5 Glulam timber bridge railing successfully crash tested to NCHRP Report 350 TL-4 (photograph taken before testing).

on some railings to assess vehicle impact forces transmitted to the bridge railing and superstructure.

RESULTS AND DISCUSSION

As a result of the development and testing program, five bridge railings were successfully developed and tested for longitudinal wood decks. Three of these railings were tested at PL-1, one was tested at PL-2, and one was tested at TL-4. Each railing was tested on the glulam timber deck and is adaptable to the spike-laminated and stress-laminated decks. All designs used posts spaced 1.9 m (6.25 ft) on center and high-strength steel bars through a portion of the bridge deck to act as reinforcement in distributing railing loads without dam-

age to the bridge. Glulam timber for the rail members was Combination 2 Douglas fir as given in the AASHTO *Standard Specifications for Highway Bridges* (1), treated with pentachlorophenol in heavy oil to AWPA C14 requirements (8). Sawn lumber for posts, curbs, scuppers, and spacer blocks was No. 1 Douglas fir (1), treated with creosote to AWPA C14 requirements (8).

A detailed discussion of the testing and results for each railing system is beyond the scope of this paper but is presented in detail in previous publications (12,13). Overall, no damage to the test bridge was evident from any of the vehicle impact tests. For the railing systems with glulam timber rails, damage to the railing was primarily gouging and scraping resulting from the vehicle impact. All glulam timber railing remained

intact and serviceable after the tests, and replacement of the railing was not considered necessary. For the steel thrie beam railings, there was permanent deformation in the rail and post in the vicinity of the impact location. This would necessitate replacement of specific railing and post members, but damage was relatively minor considering the severity of the impact. A brief description of each railing design follows.

PL-1 Railings

The three tested PL-1 railings included a glulam timber railing with curb, a glulam timber railing without curb, and a steel thrie beam railing. Photographs and drawings of the PL-1 railings are shown in Figures 2 and 3, respectively.

The glulam timber railing with curb consisted of a single glulam timber railing mounted on a sawn lumber post. The post was connected with a single bolt to a lumber curb that was supported by scupper blocks. The curb and scupper blocks were connected to the bridge deck with bolts and timber connectors.

The glulam timber railing without curb consisted of a single glulam timber railing mounted on a sawn lumber post. The lower portion of the post was placed in a steel box that was attached to the bridge deck with high strength steel bars.

The steel railing consisted of a 10-gauge steel thrie beam railing mounted to a steel, wide flange post. The lower end of the post was bolted to a steel plate that was connected to the bridge deck with high-strength steel bars.

PL-2 Railing

The one PL-2 railing included a steel thrie beam railing, as shown in Figure 4. The steel railing was a modified version of that tested at PL-1. Minor changes in the railing geometry and the addition of a steel channel section above the rail element were necessary to resist the increased loads at PL-2.

TL-4 Railing

The one TL-4 railing included a glulam timber railing with curb, as shown in Figure 5. The railing consisted of a single glulam timber railing mounted on a sawn lumber post and was a modification of the curb system tested at PL-1. Because of the greater loads at TL-4, railing and post sizes were increased, as were bolts and timber connectors attaching the curb and scupper to the bridge deck.

CONCLUDING REMARKS

This program clearly demonstrates that crashworthy railing systems are feasible for longitudinal wood decks. Even at high-impact conditions required by AASHTO PL-2 and NCHRP Report 350 TL-4, the railing systems performed well with no significant damage to the bridge superstructure. The development of crashworthy railing systems has overcome a significant barrier to the use of longitudinal deck wood bridges.

REFERENCES

1. *Standard Specifications for Highway Bridges*. AASHTO, Washington, D.C., 1989.
2. *Full-Scale Testing Procedures for Guardrails and Guide Posts*. Highway Research Circular 482. HRB, National Research Council, Washington, D.C., 1962.
3. *NCHRP Report 230: Recommended Procedures for the Safety Performance Evaluation of Highway Appurtenances*. TRB, National Research Council, Washington, D.C., 1981.
4. *Guide Specifications for Bridge Railings*. AASHTO, Washington, D.C., 1989.
5. Ross, H. E., Jr., D. L. Sicking, R. A. Zimmer, and J. D. Michie. *NCHRP Report 350: Recommended Procedures for the Safety Performance Evaluation of Highway Features*. TRB, National Research Council, Washington, D.C., 1993.
6. *Memorandum on Crash Tested Bridge Railings*. File Designation HNG-14. FHWA, U.S. Department of Transportation, Aug. 13, 1990.
7. Ritter, M. A. *Timber Bridges: Design, Construction, Inspection, and Maintenance*. Report EM-7700-8. USDA Forest Service, DC, 1990.
8. *Book of Standards*. American Wood Preservers' Association, Woodstock, Md., 1992.
9. Hinch, J., T. L. Yang, and R. Owings. *Guidance Systems for Vehicle Testings*. ENSCO, Inc., Springfield, Va., 1986.
10. *Vehicle Damage Scale for Traffic Accident Investigators*. Traffic Accident Data Project Technical Bulletin 1. National Safety Council, Chicago, Il., 1971.
11. Collision Deformation Classification; Recommended Practice J224. In *SAE Handbook*, Vol. 4, Society of Automotive Engineers, Warrendale, Pa., 1985.
12. Faller, R. K., M. A. Ritter, J. C. Holloway, B. G. Pfeifer, and B. T. Rossen. Performance Level 1 Bridge Railings for Timber Decks. In *Transportation Research Record 1419*, TRB, National Research Council, Washington, D.C., 1993.
13. Rosson, B. T., R. K. Faller, and M. A. Ritter. *Performance Level 2 and Test Level 4 Bridge Railings for Timber Decks*. In *Transportation Research Record*, TRB, National Research Council, Washington, D.C., to be published.