

5629

HIGHWAY RESEARCH BOARD
Bulletin 116

***Experimental Concrete
Pavements***

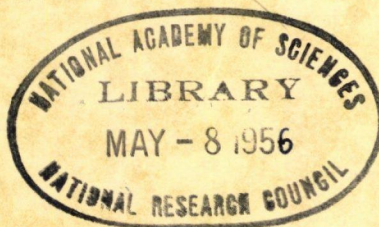

**National Academy of Sciences—
National Research Council**

publication 403

HIGHWAY RESEARCH BOARD

Officers and Members of the Executive Committee 1955

OFFICERS

G. DONALD KENNEDY, *Chairman* K. B. WOODS, *Vice Chairman*
FRED BURGGRAF, *Director* ELMER M. WARD, *Assistant Director*

Executive Committee

C. D. CURTISS, *Commissioner, Bureau of Public Roads*
A. E. JOHNSON, *Executive Secretary, American Association of State Highway Officials*
LOUIS JORDAN, *Executive Secretary, Division of Engineering and Industrial Research, National Research Council*
R. H. BALDOCK, *State Highway Engineer, Oregon State Highway Commission*
PYKE JOHNSON, *Consultant, Automotive Safety Foundation*
G. DONALD KENNEDY, *President, Portland Cement Association*
O. L. KIPP, *Assistant Commissioner and Chief Engineer, Minnesota Department of Highways*
BURTON W. MARSH, *Director, Safety and Traffic Engineering Department, American Automobile Association*
C. H. SCHOLER, *Head, Applied Mechanics Department, Kansas State College*
REX M. WHITTON, *Chief Engineer, Missouri State Highway Department*
K. B. WOODS, *Director, Joint Highway Research Project, Purdue University*

Editorial Staff

FRED BURGGRAF ELMER M. WARD WALTER J. MILLER
2101 Constitution Avenue Washington 25, D. C.

The opinions and conclusions expressed in this publication are those of the authors and not necessarily those of the Highway Research Board.

5629

EXPERIMENT
CONCRETE
PAVEMENTS
RESEARCH
PROJECTS
INDIANA
OHIO
SPENCER,
WALTER T
ALLEN, HARO
SMITH, PRESTO
ALLEN, CHARL
W.
CHILDS, L.D

N.R.C. HIGHWAY RESEARCH BOARD
Bulletin 116

***Experimental Concrete
Pavements***

PRESENTED AT THE
Thirty-Fourth Annual Meeting
January 11-14, 1955

1956
Washington, D. C.

Department of Maintenance

**M. W. Fisher, Chairman
Maintenance Engineer
State Highway Commission of Wisconsin**

COMMITTEE ON MAINTENANCE OF CONCRETE PAVEMENT AS RELATED TO THE PUMPING ACTION OF SLABS

**Carl E. Vogelgesang, Chairman
Chief Engineer
State Highway Department of Indiana**

**Charles W. Allen, Research Engineer, Ohio Department of Highways
Harold Allen, Chief, Non-Bituminous Section, Bureau of Public Roads
A. A. Anderson, Chief Highway Consultant, Portland Cement Association
W. E. Chastain, Sr., Engineer of Physical Research, Illinois Division
of Highways
George W. McAlpin, Jr., New York Department of Public Works
John W. Poulter, Chief Engineer, Koehring Company, Milwaukee
Thomas B. Pringle, Office, Chief of Engineers, Department of the Army,
Washington, D. C.
C. H. Scholer, Head, Applied Mechanics Department, Kansas State
College
T. E. Shelburne, Director of Research, Virginia Department of Highways,
University of Virginia
Bailey Tremper, Supervising Materials and Research Engineer, Cali-
fornia Division of Highways
William Van Breemen, Supervising Engineer, Engineering Research and
Soils, New Jersey State Highway Department
Dean Wilson, Maintenance Engineer, Missouri State Highway Department
K. B. Woods, Director, Joint Highway Research Project, Purdue Uni-
versity**

Contents

REPORT ON PAVEMENT RESEARCH PROJECT IN INDIANA

Walter T. Spencer, Harold Allen and Preston C. Smith 1

REPORT ON PAVEMENT RESEARCH PROJECT IN OHIO

Charles W. Allen and L. D. Childs 57

Appendix 65

Report on Pavement Research Project in Indiana

WALTER T. SPENCER, Soils Engineer, Indiana State Highway Department;
HAROLD ALLEN and PRESTON C. SMITH, Highway Physical Research Engineers,
Bureau of Public Roads

This report describes the location, design, materials, construction, traffic, and early performance of an experimental concrete pavement built in Indiana to study the effectiveness of subbases in the control of pumping.

The project is located on US 41 in the northwest corner of Indiana, beginning approximately 4.5 miles south of Cook and terminating at the south edge of Cook. Experimental sections, which have a total net length of 4 miles, serve as the southbound or west pavement of a divided highway.

Each mile of the carefully controlled test road has eight subbase sections as follows: (1) two of soil-cement mixtures with thicknesses of 3 and 5 inches; (2) three of open-graded crushed stone, with thicknesses of 3, 5, and 8 inches; and (3) three of dense-graded crushed stone, with thicknesses of 3, 5, and 8 inches. The ninth section in each mile was designated as a control section with the concrete pavement placed directly on the fine-grained soil.

The concrete pavement has a 9-8-9-inch thickened-edge section and is 24 feet wide. The first and third miles have plain concrete with contraction joints spaced 15 feet. The second and fourth miles have contraction joints spaced 40 feet.

The soils in the upper 3 feet of the subgrade are in the A-6 and A-7-6 groups. The soils in the upper 6 inches are predominately in the A-6 group, with group indices greater than 6.

Detailed tests were made to carefully control all phases of construction. Undisturbed triaxial specimens were taken from the subgrade just prior to paving. In-place CBR's were run in each section on both the subgrade and subbase.

The project has 72 Bouyoucos moisture electrodes installed in the subgrade and subbase and 2,000 precise level plugs in the concrete pavement.

The completed project was opened to traffic on November 11, 1949.

Pavement roughness indices for each lane of each section have been determined at various times.

Detailed traffic studies classify vehicles by types and weights and determine variations in traffic volumes. A speed and placement study of trucks was made in 1950.

The pavement sections having plain concrete, 15-ft. joint spacing, and no subbase have shown distress due to pumping. There has been no pumping or extrusion of material in the sections having open-graded subbase.

Further observations will be necessary to determine the relative effectiveness of the various types and thicknesses of subbases in the control of pumping. In addition to the continuation of the performance study, a program to measure the deflections of the concrete pavements under both static and moving loads was initiated late in 1953.

● INVESTIGATIONS (1) have shown that the increase in the number of heavy axle loads on the highways of the United States since 1940 has developed a phenomenon on portland cement concrete pavements known as "pumping." Pumping is the forceful ejection of a mixture of subgrade soil and water from underneath concrete pavement slabs during the passage of heavily loaded axles. It occurs at joints and cracks and along pavement edges. It may be recognized by soil stains on the pavement and by soil-water slurries at pavement edges.

Three factors are essential to produce pumping: (1) axle loads must be frequent and heavy; (2) there must be free water on the subgrade or subbase; and (3) the subgrade soil or the fine fraction of the subbase material must be fine enough to go into suspension in the free water.

If any one of these factors is absent, pumping will not occur. Continued and uncontrolled pumping results in faulting, cracking and eventual failure of the pavement.

The earlier studies indicated that pumping did not occur on subgrade soils that contained more than 55 percent retained on a No. 270 sieve. Later observations in Ohio (2) disclosed pumping on a few pavements placed on soil-aggregate subgrades containing up to 86 percent retained on the No. 200 sieve (approximately 88 percent retained on the No. 270 sieve) and having plasticity indexes greater than 7. These pavements are located in industrial areas and carry a relatively large number of heavy axle loads.

Observations made more recently in Indiana (3) indicate that the passage of extremely heavy axle loads over pavements on granular subbases may result in the ejection of sand and small gravel particles along the edges of pavements, especially adjacent to joints or cracks. However, little structural damage of the pavement due to the ejection of this coarse material has been reported.

The thickness of granular subbases required to prevent pumping could not be determined from the information developed in the investigations referred to above (1, 2). Thicknesses from 3 to 12 inches have been reported effective in preventing pumping when the materials contained more than 55 percent retained on the No. 270 sieve and had plasticity indexes less than 7.

Also, definite conclusions as to the width and drainability of subbases required to prevent pumping cannot be drawn from the reports available. Studies have included subbases placed the full width of the grade, in trench sections with longitudinal tile drains at the pavement edges and in trench sections 2 feet wider than the pavement with no drainage. The subbases in most of the full-width and tile-drained sections were either impervious or had very low permeability.

These previous investigations also showed that pumping is considerably reduced on pavements having a minimum number of expansion joints.

With these findings as a background, the experimental pavement described in this report was planned by the State Highway Department of Indiana in cooperation with the Bureau of Public Roads.

PROJECT ELEMENTS

The project is located on the southbound pavement of US Route 41 in Lake County, Indiana. The northern end of the project is approximately 9 miles south of the intersection of US Route 41 and US Route 30 (Lincoln Highway) and about 40 miles southeast of Chicago.

The large volume of heavy truck traffic and predominance of uniform fine-grained soil susceptible to pumping were the controlling factors in the selection of the site.

The experimental section serves as the southbound pavement of a divided highway and replaces a two-lane pavement built in 1927. The earthwork on the experimental project was done during the construction season of 1948 and the subbase and pavement were constructed during the summer of 1949. The pavement was opened to traffic on November 11, 1949.

Topography and Climate

The topography of the area in which the project is located is undulating to gently rolling, as shown in Figure 1. The pavement grades range from a minimum of 0.2 percent to a maximum of 1.16 percent.

The maximum temperature recorded by the Weather Bureau at Hobart station, located about 25 miles northeast of the project, is 109 F. and the minimum is -20 F. The average temperature for January is 25.6 F. and for July is 75 F. The maximum temperature at the project during the 1949 construction period was 103 F. in July, and the minimum was 28 F. in October.

The average annual rainfall recorded by the Hobart station is 34 inches. The rainfall measured by gages installed on the project was 24.43 inches during the period of May 1949 to October 1949, inclusive. The measured precipitation was 7.29 inches in July, compared to the weather bureau average of 2.85 inches. In the remaining 5 months, the total rainfall was near the weather bureau average. Although the rainfall and

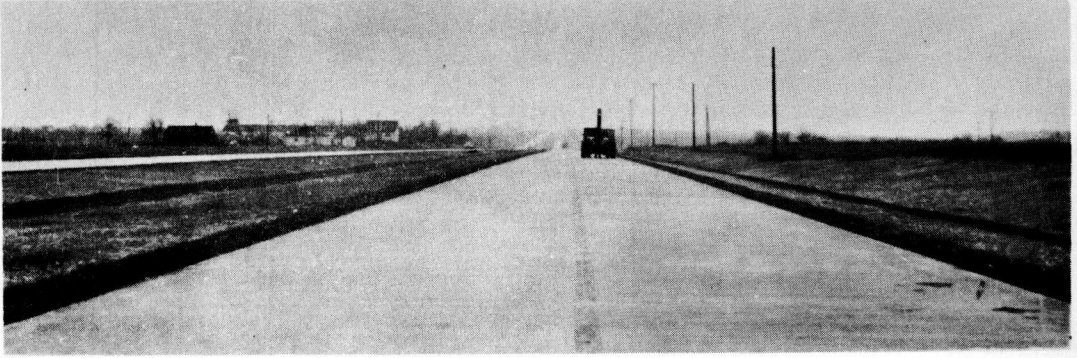

Figure 1. Project is located in undulating to gently rolling topography.

temperature data from the Hobart station and those for the project were somewhat different, those at Hobart station were considered adequate and readings on the project were discontinued after the construction was finished.

Soils

Lake County, in which the project is located, is in the Northern Moraine and Lake Region and is crossed by the Calumet Lacustrine, Kankakee Lacustrine and Valparaiso Moraine sections (4). The project is entirely within the Valparaiso morainic area, which is underlain by mixtures of silts and clays deposited during the Wisconsin glacial stage.

Pedologically, the predominating soil types throughout the length of the project are Carrington silt loam, Miami silt loam and Brookston silt loam.

It was considered necessary that the subgrade soils in the experimental project should conform to the following specification:

"The clay fraction, or particle size smaller than 0.005 mm., shall not be less than 15 percent. When the clay fraction ranges between 15 and 40 percent, the fraction retained on the No. 270 sieve, or material larger than 0.053 mm., shall not exceed 45 percent (more than 55 percent smaller). When the soil contains more than 40 percent clay, the fraction retained on the No. 270 sieve is not a controlling factor."

The investigations referred to elsewhere (1, 2) in this report indicate that concrete pavements placed on soils meeting these requirements will be susceptible to pumping.

The preliminary soil survey indicated that continuous lengths of subgrade susceptible to pumping could be built without excessive replacement of soil during grading operations. Table 1 shows the ranges in classification test values for 55 samples taken during the preliminary soil survey.

In order to make the subgrade throughout the project as uniform as possible, it was decided that the following soils should be removed and replaced with those of the A-6 and A-7-6 groups: (1) soils in the A-4 group, (2) soils in the A-7-6 group (considered to be

TABLE 1
SUMMARY OF CLASSIFICATION DATA FOR SAMPLES OBTAINED IN
THE ORIGINAL SOIL SURVEY

AASHO classification	No. of samples	Range in Soil-Test Data					
		Passing No. 200 sieve	Passing No. 270 sieve	Clay (smaller than 0.005 mm.)	Liquid limit	Plasticity index	Group index
A-4	6	Percent 38-92	Percent 35-90	Percent 12-35	18-28	6-10	1-8
A-6	33	50-89	42-86	17-53	23-38	11-20	3-13
A-7-5	1	93	88	42	52	19	7
A-7-6	15	78-94	75-91	29-56	41-53	16-32	11-19

undesirable because of the tendency to be elastic), and (3) sandy or silty pockets of soil, organic soils, and other soils not meeting the specifications.

Thus, the upper 3 feet of the subgrade were to be constructed entirely of soils in the A-6 and A-7-6 groups, all of which were within the specification limits.

NO SCALE

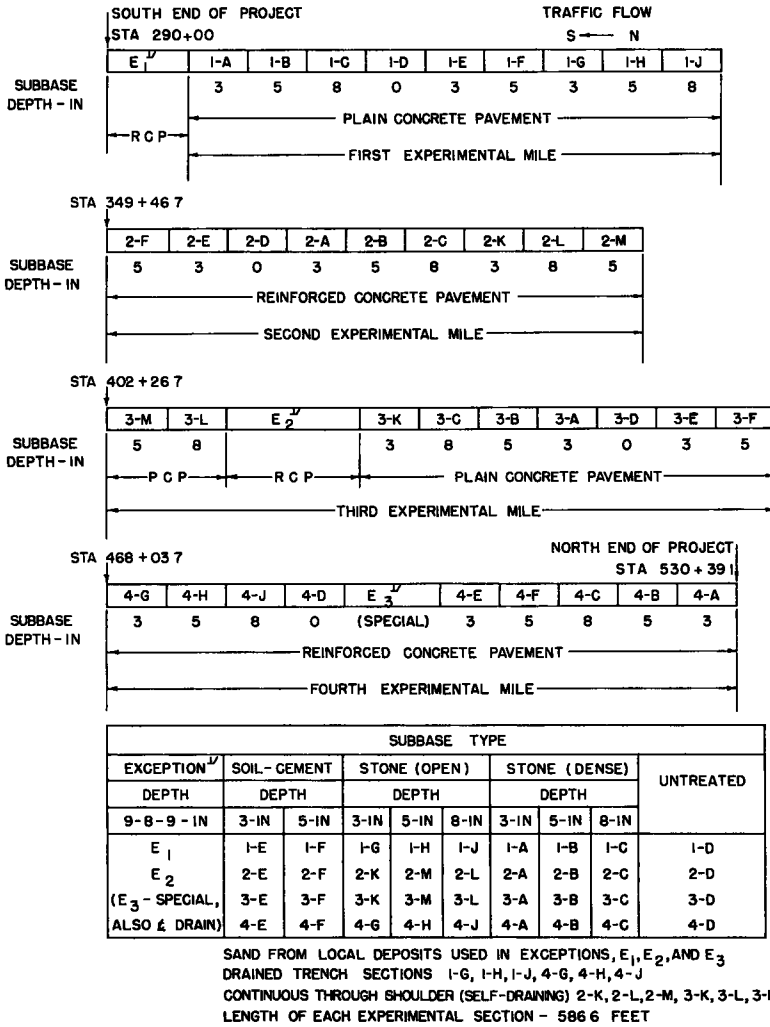

Figure 2. Plan of experimental sections.

Plan of Sections

The length of pavement included in the contract was 4.553 miles. Exceptions total 0.553 mile, making the experimental portion 4 miles in length. The project is divided into four parts, each of which includes nine experimental sections, arranged as shown in Figure 2. All sections are 586.6 feet long. For convenience, the four main divisions are designated as the first, second, third, and fourth experimental miles. On a linear basis, the first, third, and fourth "experimental miles" exceed one mile because an exception occurs with each "mile." The exceptions were made (1) to extend the pavement beyond a road intersection, (2) because of the necessity of excavating a peat deposit, and (3) to provide special drainage in an area of unusual soil stratification.

Subbases

In each of the experimental miles, the following subbases were placed: (1) two adjoining soil-cement sections, one 3 inches and the other 5 inches thick; (2) three sections composed of an open-graded, or reasonably permeable granular material, one 3 inches, one 5 inches, and one 8 inches thick; and (3) three adjoining sections of densely graded granular material with relatively low permeability, one 3 inches, one 5 inches, and one 8 inches thick. Each mile had one section in which the pavement was placed directly on the fine-grained plastic soil subgrade. This section serves as a basis for the evaluation of the performance of the subbases.

Typical sections of all subbases are shown in Figure 3.

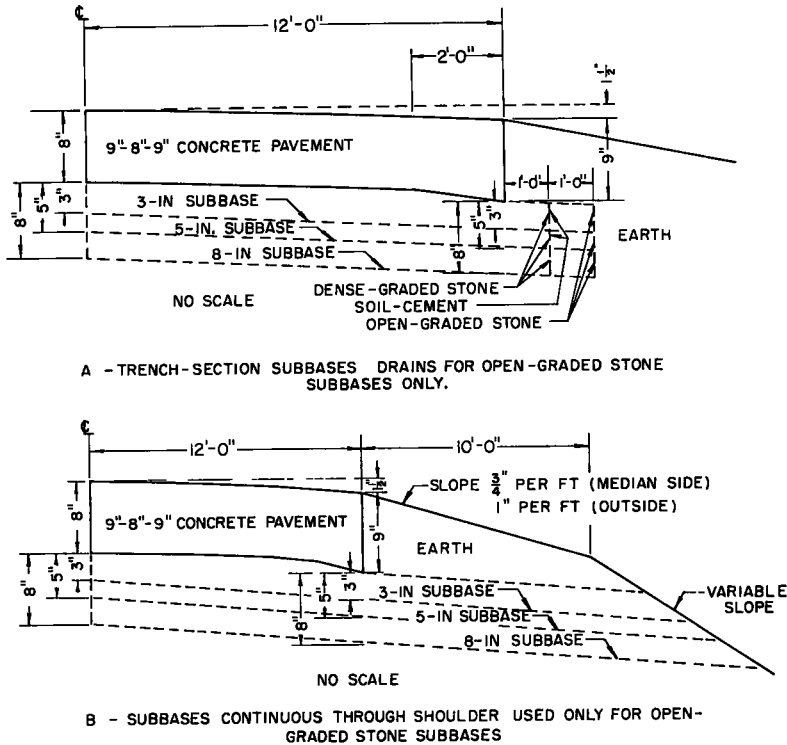

Figure 3. Typical subbase cross-sections.

The dense-graded material was placed in a trench section with the edges of the subbase extending one foot beyond each edge of the pavement. Drains were not provided for this type of subbase.

Two types of cross-section were used in placing the open-graded or permeable subbase material: (1) a trench section with lateral drains at 40- or 80-foot intervals for reinforced concrete pavement and at 47- or 75-foot intervals for plain concrete pavement, each drain being placed at a joint, and (2) full width of the roadway (shoulder slope to shoulder slope). In sections where drains were used, the subbase extends 2 feet beyond each edge of the pavement. As shown in Figure 4, each drain consists of a trench, 6 inches deep and 12 inches wide, located below the bottom of the subbase, back-filled with subbase material and connected to 4-inch vitrified clay pipes extending through each shoulder. In sections where drains were not used, the edge of the open-graded granular material is left open to provide continuous drainage.

All soil-cement subbases were constructed in a trench cross-section the same as that used for the dense-graded material.

The specifications required the contractor to select one of the following types of material for the granular subbases: (1) a combination of gravel and sand, (2) crushed

stone, or (3) air cooled blast-furnace slag. It was also required that both open-graded and dense-graded materials be obtained from the same source.

The specified gradations for both types of subbase material were as follows:

Open-graded material (Type I-M)		Dense-graded material (Type II-M) ^a	
Total percentage passing:		Total percentage passing:	
1½-inch sieve	100	1½-inch sieve	100
1-inch sieve	90-100	1-inch sieve	90-100
½-inch sieve	60-90	½-inch sieve	60-90
No. 4 sieve	30-70	No. 4 sieve	35-70
No. 30 sieve	10-30	No. 30 sieve	20-40
No. 200 sieve	0-3	No. 200 sieve	10-20

^a For Type II-M material, the fraction passing the No. 200 sieve shall not exceed one-half the amount passing the No. 30 sieve.

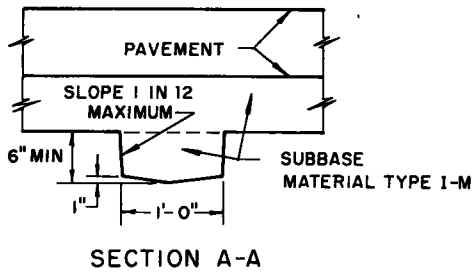
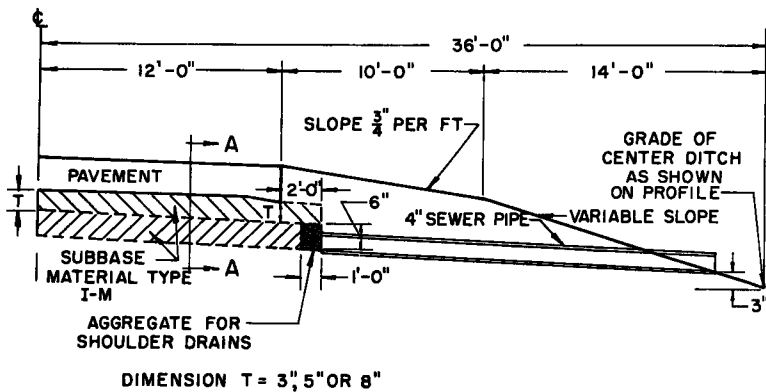

Figure 4. Typical cross-sections of drains used in trench sections of open-graded stone (type I-M), median side.

Although drainage of granular subbase depends on a number of factors, including boundary conditions and permeability of the subbase material, it was believed that determination of the coefficient of permeability of both the open- and dense-graded material might be used to explain subsequent differences in behavior of the two types of subbase materials under traffic. Consequently, permeability tests were planned for each type of subbase material having gradings and densities representative of those found in the material after final compaction of the subbase.

The physical test data for the soils used in the soil-cement subbases are given in Table 2. The cement content for these subbases was determined by the standard AASHTO procedures as described later in this report.

Pavement Design

The concrete pavement in the second and fourth miles of the experiment was designed in accordance with the 1948 Indiana standard, which required a 9-8-9-inch thickened-edge section 24 feet wide, reinforced with wire mesh weighing approximately 45 lb. per 100 sq. ft. and contraction joints spaced at 40-ft. intervals, with load-transfer devices consisting of $\frac{3}{4}$ -inch round smooth dowel bars 2 feet long spaced at 1-ft. centers. In the longitudinal joint, $\frac{5}{8}$ -inch round deformed tie bars 4 feet long spaced at 5-ft. intervals were required.

The same pavement cross-section was used in the first and third miles. However,

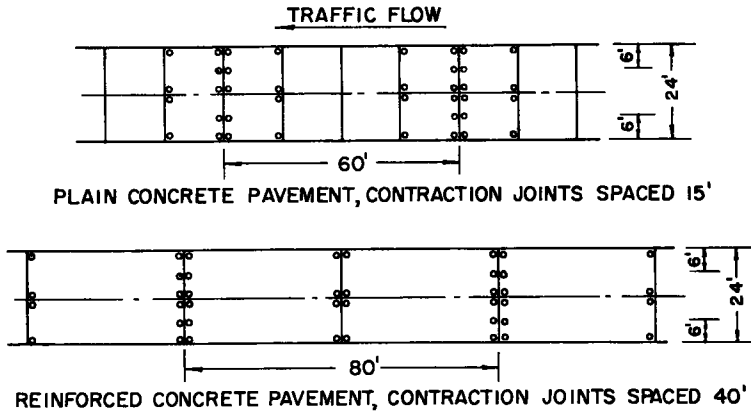

A. LEVEL POINTS FOR PLAIN AND REINFORCED CONCRETE PAVEMENTS.
ONE INSTALLATION IN EACH SECTION.

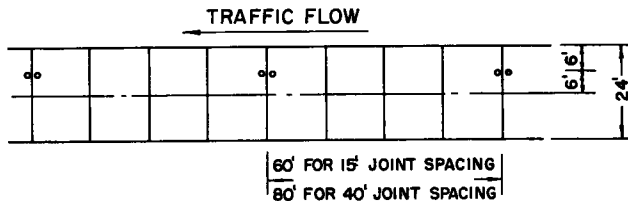

B. LEVEL POINTS FOR LONGITUDINAL PROFILES. INSTALLED THROUGH-
OUT EACH SECTION AT DESIGNATED INTERVALS

NOTE. LEVEL POINTS ARE 4 INCHES FROM CENTER OF CONTRACTION JOINTS, 8 INCHES FROM CENTER OF THE LONGITUDINAL JOINT AND 4 INCHES FROM EDGE OF PAVEMENT

Figure 5. Location of points at which periodic level readings are obtained to determine vertical movement of concrete slabs.

TABLE 2
CLASSIFICATION DATA FOR BORROW SOILS USED IN SOIL-CEMENT SUBBASES

Identifi- cation (Indiana)	Used in section	Passing No. 200 sieve	Passing No. 270 sieve	Smaller than 0.005 mm.	Liquid limit	Plasticity index	Standard compaction test		AASHO classifi- cation	
							Maximum dry density	Optimum moisture content		
		Percent	Percent	Percent			lb./cu. ft.	Percent		
50-50064	3-E, 4-E, 4-F	81	80	39	32	18	112.0	16.5	A-6(11)	
50-50065	1-E, 1-F, 2-E, 2-F, 3-F	79	78	45	41	21	103.5	19.1	A-7-6(13)	



Figure 6. Completed frost-proof bench mark.

Each truck destined for passage over the experimental pavement was weighed and classified at the pit scales and was classified again at the traffic counting station on the project.

Arrangements were made to use the Bureau of Public Roads roughness indicator to obtain roughness readings for each lane of each section before the project was opened to traffic and at periodic intervals thereafter.

Approximately 2,000 level points were placed in the pavement for the purpose of determining the vertical movement of the slabs. In order to obtain transverse profiles, 12 level points were installed adjacent to two joints in each section as shown in Figure 5-A. The joints selected are 60 feet apart in sections having a joint spacing of 15 feet and 80 feet apart in sections having a joint spacing of 40 feet. Additional level points were installed at the joints on each side of the two primary installations. Also, level points were installed at the midpoint of the outside lane, to be used in conjunction with the corresponding transverse installations to obtain longitudinal profiles of the entire experimental project. As shown in Figure 5-B, two of these level points were installed adjacent to every fourth joint in sections having a 15-ft. joint spacing, and at every second joint for sections having a 40-ft. joint spacing.

For permanent reference, a total of 13

the contraction joints were placed at intervals of 15 feet and both load-transfer devices and mesh reinforcing were omitted. The tie bars and tie bar spacings for the longitudinal joint were the same as in the reinforced pavement.

Expansion joints were not used in any of the 4 miles.

Observations and Installations for Determination of Pavement Performance

Various periodic observations were planned to study the performance of the pavement.

To make detailed traffic studies on the project, an automatic traffic counter (photo-electric type) was installed approximately 1.6 miles south of the north end of the project and adjacent to the field laboratory, where manual traffic counts are also made, and pit-scales located approximately 5 miles north of the northern end of the project are being used for weighing trucks. Weighing at a location so far removed from the project was justified from the destination information collected during the weighing operations.

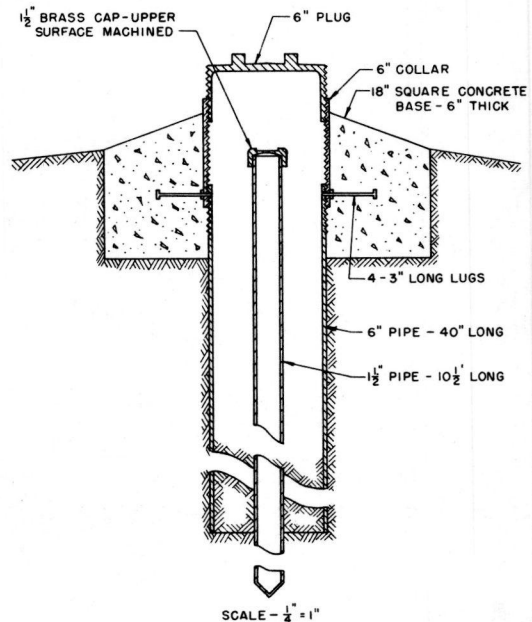

Figure 7. Sketch of frost-proof bench mark.

frost-proof bench marks were placed along the west right-of-way line and one near the east right-of-way line. A photograph of a bench mark is shown in Figure 6 and a diagram of the installation is shown in Figure 7.

Periodic observations of pumping conditions, pavement cracking, and general performance were planned.

Moisture Cells

Since the moisture content of the subgrade is one of the factors having considerable influence on pavement performance, it was considered desirable to measure the moisture content of the subgrade at various depths under the finished pavement at periodic intervals. When the project was designed, several types of units utilizing electrical resistance as a means of determining subsurface soil moisture were being investigated by soil scientists. The unit developed by Professor G. J. Bouyoucos (5) was selected for installation.

The Bouyoucos unit (Figure 8) consists of two pieces of monel metal screen acting as electrodes to which are soldered lead wires. The electrodes are separated and wrapped with nylon fabric and the whole assemblage is placed in a perforated nickel case $\frac{1}{16} \times 1\frac{3}{8} \times 1\frac{5}{8}$ inches in size. The nylon fabric absorbs moisture from the soil and gives it up to the soil readily. When the nylon unit is buried in the soil, its moisture content tends to achieve and maintain equilibrium with that of the soil. The electrical resistance of the unit varies inversely with its moisture content and is an index to moisture in the soil. The resistance of each unit is measured by means of a modified Wheatstone bridge and the moisture content is read from a calibration curve. It is estimated that the useful life of these units will be between five and ten years.

The location, grouping, and vertical depth of the units installed are given in Table 3. Nine groups, or a total of 66 units, were placed under the concrete pavement at depths varying from $2\frac{1}{2}$ inches above the subgrade (5-inch granular subbases only) to 12 inches below the top of the subgrade.

One group of six units was placed in the natural soil just inside the right-of-way near the field laboratory. This group was installed (1) so the moisture contents as determined by the units could be checked with those obtained from borings made adjacent to the units and (2) to determine the durability of both the nylon fabric used in the units and the insulation on the lead wires recommended for use.

CONSTRUCTION

Extensive tests and observations were made during construction of the project not only to insure that work was done in accordance with the specifications but also to obtain the necessary basic data from which variations in pavement performance could be analyzed. To aid in construction control and collection of field data, the field laboratory shown in Figure 9 was constructed on the project. The mobile soils laboratory of the Bureau of Public Roads was also used on the project during construction of the subbases.

Grading

The earth work required to bring the road section to subgrade elevation was done in

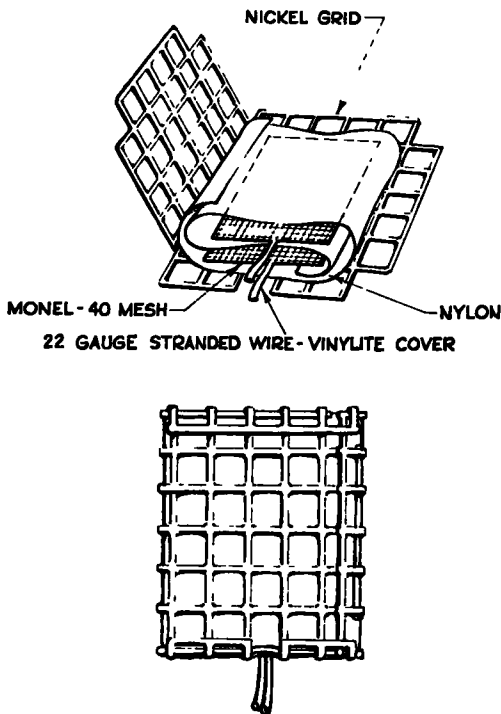

Figure 8. Bouyoucos nickel-nylon moisture cell.

accordance with standard practice in Indiana. The embankments were placed in layers having a maximum thickness of 8 inches (loose measurement) and compacted to a minimum of 95 percent of maximum wet density (AASHO Method T99). A 10-ton 3-wheel roller was used for embankment and subgrade compaction. Considerable borrow was required, all of which was obtained from one pit.

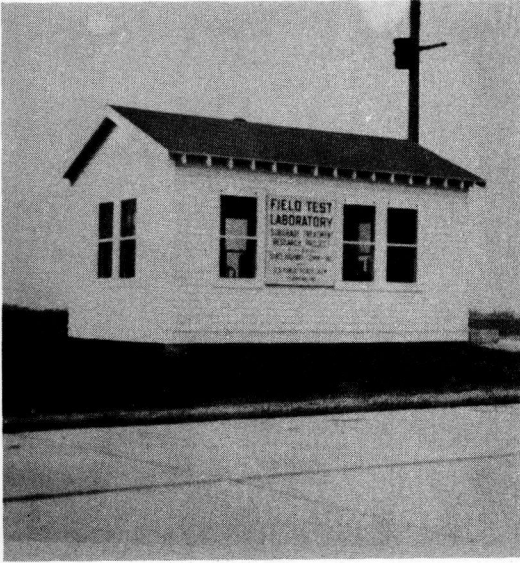

Figure 9. Project field laboratory.

As previously noted, the experimental project replaces an old pavement. When the old slab was 3 feet or less from the top of the finished subgrade, it was removed. Below a depth of 3 feet, the old slab was broken up into pieces not to exceed $\frac{1}{2}$ sq. yd. in size and left in place.

After completion of the grading, borings were made to a depth of 3 feet at the centerline and pavement edges at each station, and at any necessary intermediate points to establish the vertical and lateral soil distribution or soil profile on the basis of group index numbers. Examination of the test results from typical soil samples and of the boring data disclosed that all the soils were in the A-6 and A-7-6

TABLE 3
LOCATION DATA FOR BOUYOCOS MOISTURE-CELL UNIT INSTALLATIONS

Section	Subbase type	Pavement type	Contraction joint spacing	No. of units in each series ^a	Distance rt. of \square of pavement - each series	Longitudinal distance north of contraction joint - each series	Distance from top of subgrade		Station at installation location
							Above	Below	
							Feet	Inches	
1-E	Soil-cement, 3-inch depth	Plain	15	3	0.5	1.0	-	$\frac{1}{2}$ +, 6, 12	324 + 09.4
				3	11.0	1.0	-	$\frac{1}{2}$ -, 6, 12	
1-F	Soil-cement, 5-inch depth	Plain	15	3	11.0	1.0	-	$\frac{1}{2}$ +, 6, 12	327 + 54.4
				3	11.0	7.5	-	$\frac{1}{2}$ -, 6, 12	327 + 61.7
2-D	No subbase	Reinforced	40	3	0.5	1.0	-	$\frac{1}{2}$ +, 6, 12	362 + 27.7
				3	11.0	1.0	-	$\frac{1}{2}$ -, 6, 12	
2-M	Open-graded stone, 5-inch depth	Reinforced	40	4	0.5	1.0	$2\frac{1}{2}$	$\frac{1}{2}$ +, 6, 12	398 + 17.3
				4	11.0	1.0	$2\frac{1}{2}$	$\frac{1}{2}$ -, 6, 12	
3-B	Dense-graded stone, 5-inch depth	Plain	15	4	0.5	1.0	$2\frac{1}{2}$	$\frac{1}{2}$ +, 6, 12	441 + 97.4
				4	11.0	1.0	$2\frac{1}{2}$	$\frac{1}{2}$ -, 6, 12	
4-H	Open-graded stone, 5-inch depth (drained joint, trench x-section)	Reinforced	40	4	0.5	1.0	$2\frac{1}{2}$	$\frac{1}{2}$ +, 6, 12	474 + 84.4
				4	11.0	1.0	$2\frac{1}{2}$	$\frac{1}{2}$ -, 6, 12	
4-H	Open-graded stone, 5-inch depth (undrained joint, trench x-section)	Reinforced	40	4	0.5	1.0	$2\frac{1}{2}$	$\frac{1}{2}$ +, 6, 12	475 + 24.4
				4	11.0	1.0	$2\frac{1}{2}$	$\frac{1}{2}$ -, 6, 12	
4-B	Dense-graded stone, 5-inch depth	Reinforced	40	4	0.5	1.0	$2\frac{1}{2}$	$\frac{1}{2}$ +, 6, 12	520 + 09.5
				4	11.0	1.0	$2\frac{1}{2}$	$\frac{1}{2}$ -, 6, 12	
				4	0.5	20.0	$2\frac{1}{2}$	$\frac{1}{2}$ +, 6, 12	
				4	11.0	20.0	$2\frac{1}{2}$	$\frac{1}{2}$ -, 6, 12	
Adjacent to 3-A	Installation adjacent to R/W line (check installation)	-	-	6	54.0	-	-	6, 12, 18 ^b 24, 36, 48	449 + 00

^a A series is a group of units placed directly below each other at the indicated locations.

^b Distances below ground surface.

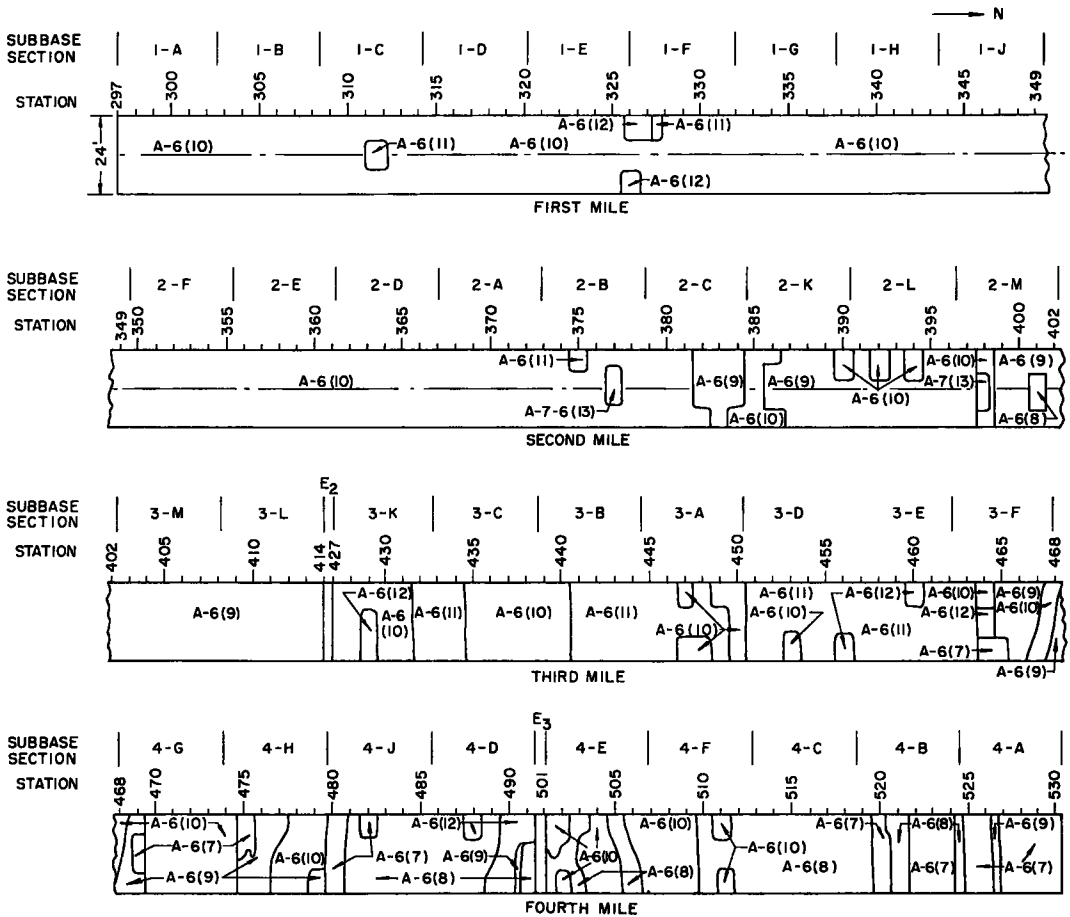

Figure 10. Distribution of soils in upper six inches of the subgrade on basis of the group index.

groups, with the former predominating. The group indexes ranged from 6 to 17.

The characteristics and classification of the soils in the upper 6 inches of the finished subgrade are shown in Table 4, and the distribution on the basis of group indexes is shown in Figure 10¹. The data show that 46 of the 48 samples taken from the top 6 inches of the subgrade are in the A-6 group and that 39, or 83 percent, have group indexes ranging from 8 to 11, inclusive. For 18 of the samples, the group index is 10.

Figure 10 shows that the subgrade soil of the first experimental mile and the southern half of the second mile is in the A-6 group, most of the soil having a group index of 10 and minor amounts with group indexes of 11 or 12. The subgrade soils of the third and fourth miles and the northern half of the second mile are more variable.

However, all of the soils in the subgrade immediately under the pavement are sufficiently uniform to permit comparisons of performance of the slabs placed over the various sections. A comparison of the data with the specifications show that the subgrade soils in all of the sections conform to the requirements and, therefore, all of the experimental sections are on subgrades that will "pump" under the proper rainfall and traffic conditions.

¹ Later sampling for CBR and triaxial tests showed some disagreement with group indexes for some areas of the initial map. Some adjustment of soil boundaries and group indexes was necessary to make the strip map more reliable. Therefore, the group index shown for some of the areas is the average for two or more samples obtained at approximately the same location.

TABLE 4
SUMMARY OF CLASSIFICATION DATA FOR SOILS IN THE UPPER 6 INCHES OF THE COMPLETED SUBGRADE

AASHO classification		Number of samples	Passing No. 200 sieve		Passing No. 270 sieve		Clay (smaller than 0.005 mm.)		Liquid limit		Plasticity index	
Group	Group index		Average	Range	Average	Range	Average	Range	Average	Range	Average	Range
			Percent	Percent	Percent	Percent	Percent	Percent	Average	Range	Average	Range
A-6	7	3	65	63-66	63	61-64	31	30-31	27	27-29	12	12-13
A-6	8	8	69	65-74	67	63-71	33	30-36	29	27-30	13	11-15
A-6	9	5	72	67-77	70	67-75	36	31-40	30	28-33	14	12-17
A-6	10	18	77	67-84	75	65-82	38	28-45	33	31-39	16	15-20
A-6	11	8	77	69-81	76	67-80	40	34-45	35	34-39	17	16-21
A-6	12	4	80	78-82	79	77-80	43	42-44	40	39-40	20	20-21
A-7-6	13	1	78	-	78	-	39	-	42	-	21	-
A-7-6	14	1	82	-	80	-	47	-	44	-	23	-

Subgrade Density and Moisture Controlled

The specifications provided that the moisture content of the upper 6 inches of the subgrade at the time the subbase or pavement were placed should be at optimum or not more than two percentage points above optimum, and that the dry density should be at least 95 percent of the maximum as determined by the Standard Method of Test for the Compaction and Density of Soils, AASHO Designation T99.

In-place density tests of the compacted subgrades were made in accordance with the current Indiana specification, which is similar to the Standard Method of Test for Field Determination of Density of Soil in Place, AASHO Designation T147-49 (Method A). In this method the density of soil is determined by finding the weight and moisture content of a disturbed sample and measuring the volume of the hole from which the sample was removed. Sand of uniform size and known weight per cubic foot was used as the medium for measuring the volume of the holes from which the density samples were taken.

Three in-place density tests were made in the subgrade of each section prior to placing the subbase. Four density tests were made in untreated section 4-D and three tests in each of the other three untreated sections, several days prior to paving. Results of these in-place density and moisture-content tests are summarized in Table 5.

The dry density as determined by these tests varied from 106 to 126 pcf., with an average of 116 pcf. The average relative compaction was 104 percent of the maximum dry density determined by the laboratory compaction test (AASHO Designation T99). The tests indicated that all portions of the subgrade had been compacted to at least 95 percent of the control dry density, the highest being 113 percent.

For the 107 tests, 27 moisture contents were within 2 percentage points above the

TABLE 5
IN-PLACE DENSITY AND MOISTURE CONTENT OF UPPER 6 INCHES OF SUBGRADE AT TIME OF PLACING SUBBASES OR PAVEMENT

Thickness and type of subbase	No. of tests	In-place dry density		Percentage of standard compaction			Moisture content										
							In-place			Optimum			No. tests above optimum		No. tests below optimum		
													Percentage points	Percentage points	Percentage points	Percentage points	
Max.	Min.	Ave.	Max.	Min.	Ave.	Max.	Min.	Ave.	Max.	Min.	Ave.	0-2	0.1 or more	0.1-2.0	2.1 or more		
		pcf.						percent			percent						
3" dense-graded	12	121	109	117	108	95	104	17	11	14	17	14	16	2	1	3	6
5" dense-graded	12	126	109	117	110	99	104	18	9	14	17	14	16	3	0	6	3
8" dense-graded	12	124	113	118	111	101	104	18	11	14	17	14	15	4	0	5	3
3" open-graded	12	122	113	117	113	102	106	17	9	14	17	15	16	4	0	2	6
5" open-graded	12	124	113	120	111	101	106	16	11	13	16	14	15	1	0	3	8
8" open-graded	11 ^a	126	114	119	113	102	105	16	12	13	16	14	15	2	0	4	5
3" soil-cement	12	121	106	111	106	96	100	19	14	16	17	14	16	6	0	6	0
5" soil-cement	11 ^a	118	108	111	104	96	99	21	15	17	17	14	16	3	3	5	0
Untreated	13	124	106	118	112	95	107	21	13	15	18	14	16	2	2	4	5
Mile one	27	126	108	115	113	95	104	21	12	15	17	16	16	5	2	9	11
Mile two	26	124	107	116	111	95	103	18	11	15	17	14	16	10	1	11	4
Mile three	27	124	106	116	113	96	104	21	11	15	18	15	16	5	2	6	14
Mile four	27	126	112	119	112	97	105	18	9	13	18	14	15	7	2	12	6
Entire Project	107	126	106	116	113	95	104	21	9	15	18	14	16	27	7	38	35

^a One test omitted because of erroneous data.

respective optimum moisture contents, 7 were more than 2 points above, 38 were within 2 points below, and 35 were more than 2 percentage points below optimum moisture content. Thus, 68 percent of the moisture contents for all sections were below optimum. The moisture contents ranged from 5.1 and 7.6 percentage points below optimum to 4.8 and 3.9 percentage points above optimum for subgrades of untreated and subbase sections, respectively.

The large proportion of moisture contents below the optimum indicates the difficulty in maintaining the proper subgrade moisture content when the subgrade is exposed. The

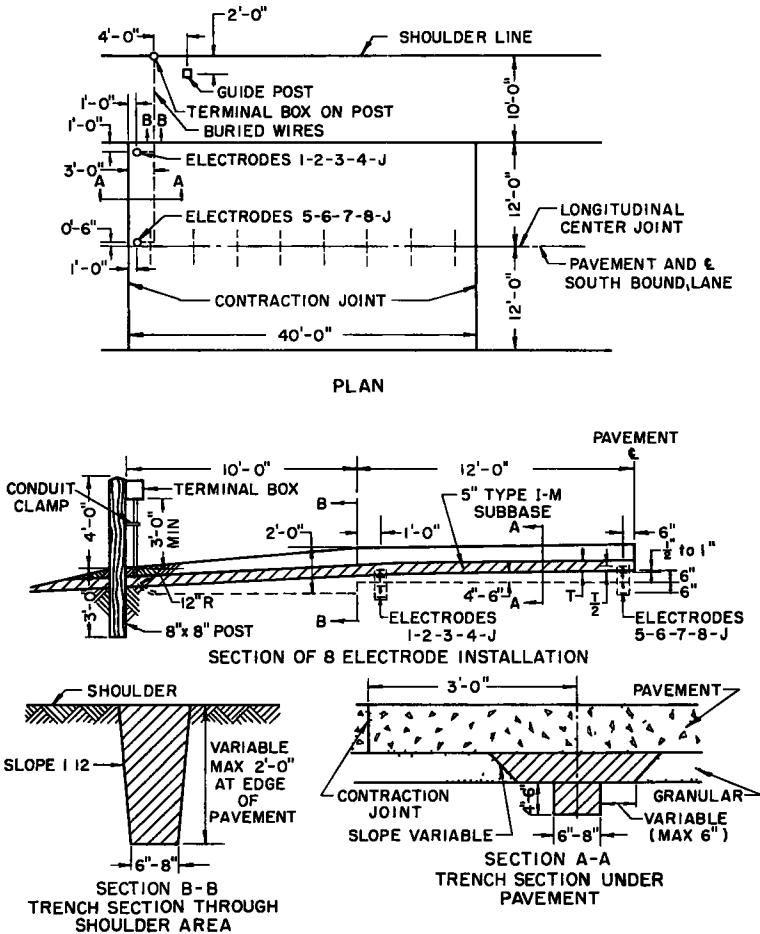

Figure 11. Plan of 8 unit Bouyoucos electrode installation at station 398+17.3, in 5-inch, open-graded stone (type I-M) subbase section.

subgrade was sprinkled frequently after completion and some portions having a moisture deficiency were scarified, sufficient water was added to satisfy the deficiency, and recompactd just prior to placement of the subbase.

Moisture Cell Installation

Soon after the subgrade was constructed, moisture cells were installed in the subgrade at the locations given in Table 3. The plan of a typical installation is shown in Figure 11.

The soil was removed in layers from the section in which the moisture-cell units were to be buried and each soil increment placed on the adjacent subgrade surface. When the hole was filled, each increment was replaced at approximately the same level from which it was removed.

A sample of soil was obtained at the level of each unit for use in calibration of the cell and performance of soil classification tests, and additional soil from the same level was passed through a No. 10 sieve for use in the zone surrounding the cell.

Sufficient water was added to one portion of the sieved sample to form a slurry. Just before each unit was placed, it was covered with a thin coat of the slurry. The unit was bedded in a shallow layer of the sieved material and a small amount of the sieved soil was used to cover it. Each increment of soil was replaced and thoroughly tamped. Although in-place density tests were not made on the replaced soil, care was taken to tamp the soil so that, by visual observation, its density appeared to be equal to or greater than that of the adjacent subgrade soil. Coating the unit with the slurry provided intimate contact with the soil; the sieved material above and below the unit provided protection during the tamping process.

Units to be located at the top of the subgrade were installed temporarily and protected by a steel plate during construction of the subbase. After the subbase was constructed, the plate and the overlying material were removed, the installation completed, and the subbase replaced.

After the units were in place, and the trench from the installations to the subbase edge backfilled, the remaining lengths of lead wires were coiled, wrapped in heavy water-proofed paper and buried in a pit in the shoulder. Before the pit was backfilled, boards were placed over the wrapped wire.

Connection of lead wires to the terminal boxes which were mounted on posts were made after major construction operations were completed to avoid the possibility of disturbance by construction equipment.

To insure proper identification of the units at various depths and lateral positions, different colored lead wires were used and each wire tagged.

Soil-Cement Subbases

All of the soil used in the soil-cement subbases was obtained from a borrow pit located near the south end of the project. The soil used in sections 3-E, 4-E, and 4-F was excavated by means of a dragline and, as shown in Table 2, its AASHTO classification was A-6(11). The soil used in the remainder of the soil-cement subbase sections was excavated by means of tractor-scrappers and its AASHTO classification was A-7-6(13).

Except for a modification of soil-pulverization requirements, the following standard test procedures were used to determine the cement content of the cement-treated sections: Standard Method of Test for Moisture-Density Relations of Soil-Cement Mixtures, Standard Method of Wetting-and-Drying Test of Compacted Soil-Cement Mixtures, and Standard Method of Freezing-and-Thawing Test of Compacted Soil-Cement Mixtures, AASHTO Designations T134-45, T135-45, and T136-45, respectively.

Specifications required that the soil should be pulverized until a minimum of 70 percent, exclusive of stone, passed the No. 4 sieve, as compared with 80 percent required in most specifications. Although durability tests made in accordance with AASHTO standards indicated that a cement content of 13 percent would be required to obtain satisfactory hardening of the borrow soil used in the soil-cement subbases, it was considered desirable to determine the effect of the minimum field pulverization requirement on the test results. Accordingly, a second set of laboratory tests were made.

Based on the assumption that the maximum size of unpulverized soil aggregations in the field would be approximately $\frac{1}{2}$ inch, the second group of durability tests were made on soil-cement mixtures which contained 30 percent of soil lumps ranging from $\frac{1}{4}$ to $\frac{1}{2}$ inch in size. The losses caused by freezing-thawing and wetting-drying tests indicated a cement content of 15 percent would be necessary for hardening.

However, examination of some of the test cylinders showed that a considerable portion of the loss was due to an excessive accumulation of $\frac{1}{4}$ to $\frac{1}{2}$ -inch lumps around the top edge which caused the breaching off of large pieces. Therefore, it was decided to make check tests in which particular attention would be given to obtaining a uniform distribution of the soil lumps throughout the mixture. These check tests showed that 14 percent of cement was sufficient for satisfactory hardening of the mixture containing the soil lumps. Data from these tests were not available until after construction of the

soil-cement subbase had started so two sections, 3-E and 4-F, have a cement content of 15 percent, and the remaining six sections have a cement content of 14 percent, by volume.

Specifications provided for optional use of equipment such as disc harrows, plows, etc., or traveling mixing machines for pulverizing and mixing. A traveling mixing machine was selected by the contractor for processing the cement-treated sections. This equipment is shown in Figure 12.

A typical cross-section for the concrete pavement and the soil-cement subbase is shown in Figure 3A. The bottom of the subbase cross-section is formed by a straight line from the center line to the edges and the top conforms to the crown and thickened edge of the pavement. This condition presented a rather serious construction problem



Figure 12. Equipment used in processing soil-cement subbase material. At top is rear view of the single-pass processing unit; at bottom, mixer box elevated to show: (A) cutting rotor; (B) shaping blades; and (C) mixing blades.

since the mixing machine processed to a uniform depth. To make the uniform processing depth obtained with the mixing machine congruous with construction of the final section, the plan cross-section was converted to a rectangular section having a depth sufficient to produce an equivalent volume. Sufficient untreated material, obtained from the borrow pit, was placed at the approximate maximum density as determined by means of the standard moisture-density test to obtain the compacted depths required to conform to the converted cross-section. A blade grader was used for shaping the surface of the untreated soil in preparation for construction. Before the processing operation started, the equipment was adjusted so that the desired depth of mixing was obtained.

Processing of the soil-cement was done in accordance with procedures which have been satisfactorily used for several years, hence, most of the details are omitted in this report.

The 26-ft. width of soil-cement subbase was processed in three strips. After the outer strips were compacted, paving forms were set. The forms were used for fine grading the subbase and for placing the pavement.

The specifications required that the moisture content of the mixture at time of

TABLE 6
IN-PLACE DENSITY AND MOISTURE CONTENT OF COMPACTED SOIL-CEMENT MIXTURES

Section No	Subbase thickness	In-place dry density ^a					Moisture content						
		Range	Average	No tests 5 0 pcf or more below control density ^b	Percentage of control density ^b		From in-place density test		Optimum ^b		During field compaction		Percentage of optimum
					Range	Average	Range	Average	Range	Average	Range	Average	
Inches	pcf	pcf				percent	percent	percent	percent	percent	percent	percent	
1-E	3	91-104	97	2	91-104	97	21 0-24.6	23 0	24 0	24 0	20 3-22 4	21 2	88
1-F	5	97-100	98	0	100-107	104	19 6-24 5	22.8	23.8-27.5	26.6	20, 2-26.9	23.6	89
2-E	3	93-101	97	1	94-102	98	24.3-31.4	26.7	23.9	23.9	20, 2-25.5	22.8	95
2-F	5	93-106	98	1	95-108	100	21.7-24.7	23.2	23.1-23 8	23 3	22 6-23 9	23 2	100
3-E	3	98-102	101	0	98-102	101	19 9-21 3	20.6	21 3-23 2	22.7	20, 9-23 4	22.8	100
3-F	5	95-104	100	2	92-100	96	22 6-27.5	24.4	21.0	21.0	19, 9-20 8	20 4	97
4-E	3	101-107	103	0	98-104	100	18.3-24.1	21 5	21.5	21.5	19, 5-22 7	20, 8	97
4-F	5	100-103	102	1	94-98	97	21 2-24.4	22 4	20 0-20 1	20.1	18 8-22.6	21 2	106
3-inch sections			99	3		99		23 0		23 0		21 9	95
5-inch sections			99	4		99		23.4		22.7		22 2	97
All sections			99	7		99		23.2		22.9		22 0	96

^a Four in-place density tests made in each section.

^b Control compaction test conformed to AASHO Designation T 134-45 except that compaction material was obtained from the processed mixture in the field and new material was used for each point on the compaction curve.

compaction should not be less than the optimum moisture content as determined by the standard method of test for Moisture-Density Relations of Soil-Cement Mixtures (AAS HO Designation T134-45). However, the moisture content of the unprocessed soil was so variable that it was difficult to predetermine the amount of water to add, and considerable reliance was placed on visual inspection for control of the application of water to the mixture. Table 6 shows average moisture contents determined on four samples of the mixture from each section, except section 4-F, during field compaction. Three samples were obtained from section 4-F. The average moisture content in sections 2-F, 3-E, and 4-F was at least 100 percent of optimum, but in the remainder of the sections it ranged from 88 to 97 percent of optimum. The average for all sections was 96 percent of optimum moisture content.

Tests were also made to determine that the processing machine was pulverizing the soil to the extent that at least 70 percent, based on the oven-dry weight of the soil, would pass the No. 4 sieve. Table 7 shows that the average pulverization for each section was greater than 70 percent and the average of 43 tests for all sections was 72.6 percent. The highest percentage for one test was 80.3. Nine tests, representing limited areas, showed pulverization percentages ranging between 62.2 and the minimum requirement of 70. As soon as visual inspection indicated insufficient pulverization, processing procedures were changed. Pulverization tests were made on samples from these areas to determine the need for construction changes. Normally, to obtain proper mixing and pulverization, the mixing machine could not be operated at a speed greater than 6.2 ft. per minute.

The densities used as standards in compaction control were the maximum values obtained by means of the Standard Method of Test for Moisture-Density Relations of

TABLE 7
DEGREE OF PULVERIZATION OBTAINED DURING
PROCESSING OF SOIL FOR SOIL-CEMENT SUBBASE
MIXTURES

Section No	Subbase thickness	Pulverization ^a			
			No. of tests	Range	Average
				percent	percent
Inches					
1-E	3	4	73.1-77.4	74.6	
1-F	5	6	66.2-78.5	73.4	
2-E	3	6	66.5-75.1	70.4	
2-F	5	9	67.1-77.1	72.0	
3-E	3	2	69.3-80.3	74.8	
3-F	5	5	70.5-75.8	73.1	
4-E	3	4	68.9-75.9	72.5	
4-F	5	7	62.2-78.7	72.8	
All sections		43	62.2-80.3	72.6	

^a Percentage passing No. 4 sieve, based on oven-dry weight of soil, exclusive of gravel or stone.

Soil-Cement Mixtures, AASHO Designation T134-45, except that (1) the mixture was not passed through the No. 4 sieve, and (2) new material, taken from the grade after completion of the wet mixing process, was used for each point on the compaction curve to insure the same degree of pulverization for both the control-standard and field tests.

The sand method was used to obtain the field densities of the soil-cement subbases. Several series of check tests made in the same holes by both the sand and the oil methods showed that the data obtained by either method should check within a variation of one pcf.

Four in-place density tests were made in each section after final compaction. The average percentage of compaction for the 32 density tests was 99, as shown in Table 6. In seven in-place density tests the dry density was 5.0 pcf., or more, below the corresponding control density, the maximum deficiency being 8.9 pcf. in section 1-E. Five of these seven field density tests were not made until at least 13 days after final compaction of the subbase. Because the personnel who were making the field density tests were also making control tests on other sections under construction at the same time, once it was ascertained that a certain construction procedure resulted in a satisfactory density, the remainder of the density tests were made at various time intervals subsequent to construction.

Considerable difficulty was encountered in keeping within the desired tolerance of $\pm 1/2$ inch of the specified depths and also in keeping the correct elevation of the cross-section with respect to the required grade. To assist in control of the subbase thickness and elevation without setting forms, fine-grade stakes were spaced at 25-ft. intervals at the centerline, quarter points and edges of the subbase. The surface was bladed to conform to a tolerance of $1/4$ inch from the tops of these stakes.

A factor which influenced the shape of the bottom of the treatment was a variation in

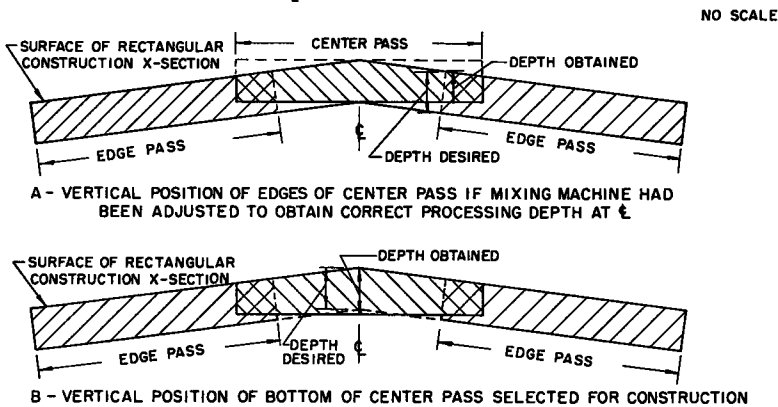

Figure 13. Selection of vertical position of center pass with respect to that of edge passes of mixing machine.

the slope of the operating plane for the edge passes and the center pass of the mixing machine. The relative positions of the portions of the cross-section processed by each pass of the mixing machine are shown by the diagrams of Figure 13. If the positions in 13A were used, the thicknesses of the processed material on each side of the center would have been deficient. If set so that the desired thickness would be obtained at the junction of the center and end passes, the thickness at the center would have been greater than necessary. Final adjustment of the depth of cut for the center pass was such that it was slightly excessive at the center and slightly deficient at the junction of the center and edge passes. The final cross-section is shown in Figure 13B.

Difficulty was encountered in compaction and fine-grading of the soil-cement subbase adjacent to the paving form. From 2 feet inside the form to the form line, a drop of $1 3/8$ inches in the subbase surface was required to provide for the thickened-edge pavement section, while the crown of the remainder of the subbase was considerably less. Consequently, when attempting to use the 10-ton 3-wheel roller to compact the 2-ft. strip to the required crown, one roller wheel was supported on the high or inside edge of the strip and failed to do more than flatten the material adjacent to the form. This condition is shown in Figure 14. Proper compaction could not be obtained with a pneumatic-tired roller. To obtain adequate compaction with the 3-wheel roller, it was necessary to leave excess material along the form line. It was decided to delay removal of the excess material until the treatment hardened. When the blading operation was started, it was soon apparent that, at best, a rough surface would be obtained. In a few instances compaction planes were encountered and a thin layer of hardened material torn from the surface, as illustrated in Figure 15. However, the occurrence of these areas was limited.

In addition to the mechanical difficulties encountered during construction in obtaining the design section, the type of soil being processed directly influenced the accuracy of measurements made to determine finished treatment thicknesses. The soil was so tough that the shattering effect of the cutting teeth and the action of the planer or shaping blades, located behind the cutting teeth, did not level the material between the teeth. As a consequence, a corrugated rather than a smooth surface was obtained for the bottom of the subbase. The variations from a true plane ranged from a maximum of $\frac{1}{2}$ inch in localized areas to lesser ones at other locations. These corrugations, shown in Figure 16, made the measurement of thickness of the subbase difficult and somewhat uncertain.

Thirty-six subbase-thickness measurements were recorded. Of this total one was equal to, 18 were less and 17 were more than the plan thickness. In the group of 18 measurements, 10 were within the project tolerance of $\frac{1}{2}$ inch, 5 were between $\frac{1}{2}$ and $\frac{3}{4}$ inch, and 3 between $\frac{3}{4}$ and $\frac{7}{8}$ inch less than the plan thicknesses. In the group of 17 measurements, 9 were within the project tolerance of $\frac{1}{2}$ inch, 4 were between $\frac{1}{2}$ and $\frac{3}{4}$ inch and 2 between $\frac{3}{4}$ and 1 inch greater than plan thicknesses. One reading of plus $1\frac{7}{16}$ and one of plus $1\frac{9}{16}$ were obtained. In this group of 36 thickness measurements, 55.6 percent were within the project tolerance of $\pm\frac{1}{2}$ inch, 38.8 percent between $\frac{1}{2}$ and 1 inch of the plan thickness and 5.6 percent were more than 1 inch greater than the plan thickness.

Regardless of the variation in thickness caused by conditions noted previously, the cement-treated sections are sound structurally and the dimensions sufficiently accurate to determine any major difference in performance between the 3-inch and the 5-inch

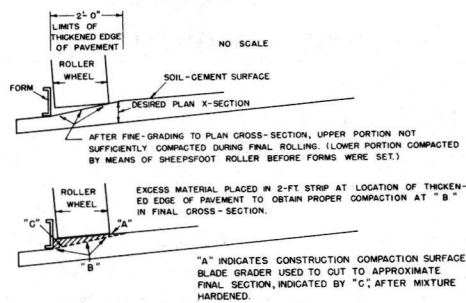

Figure 14. Procedure used for compacting cement-treated subgrade at location of thickened pavement edge.



Figure 15. Condition of soil-cement surface along form line caused by blading after mixture hardened. Locations at which this condition occurred were infrequent.

thicknesses. Cross-sections were taken on the subgrade surface before processing and on the surface of the completed treatments. These sections and the thickness measurements will be available for correlation purposes, with respect to thicknesses, in the event that subsequent observations show unusual performance variations.

Granular Subbases

As previously noted, it was necessary to sprinkle the completed subgrade to maintain the desired moisture content until the subbase was placed. To prevent the subgrade surface from being soaked by excess water which was occasionally brought in with the subbase material, sprinkling was discontinued far enough in advance of subbase construction to permit the formation of a thin dry crust at the surface of the subgrade. Also, this procedure minimized the possibility of

intrusion of the subgrade soil during construction of the initial lift of open-graded subbases. This precaution was particularly necessary in construction of the 3-inch open-graded subbases because they required more rolling than the other subbases to obtain the required density.

Of the three permissible types of granular subbase material, gravel-sand, crushed stone, or slag, the contractor decided to use crushed stone from a commercial limestone quarry located approximately 30 miles from the northern end of the project. The open-graded stone was produced by washing some of the fines from a normal quarry product and adding material greater than $\frac{1}{2}$ inch in size. The

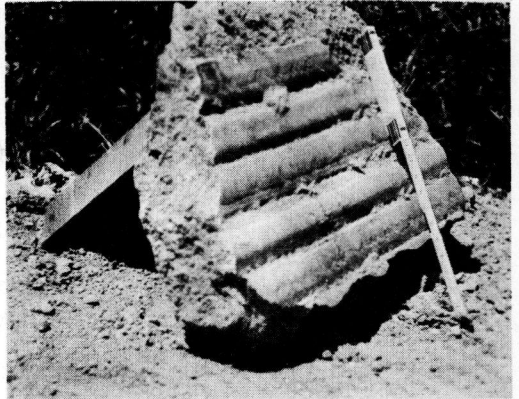

Figure 16. Corrugations formed on the bottom of the soil-cement subbase.

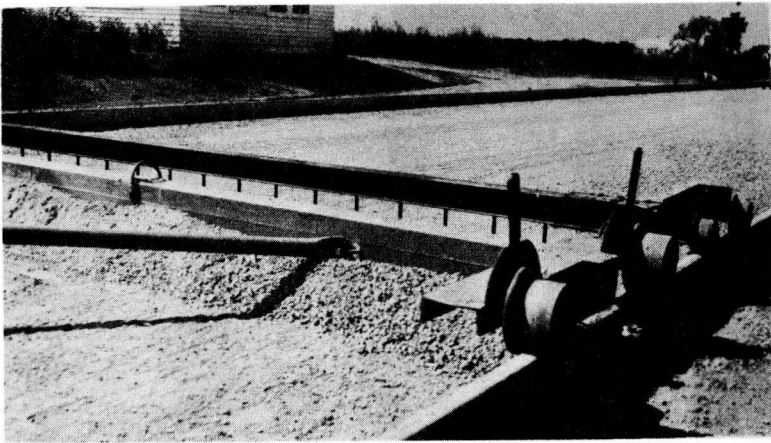

Figure 17. Segregation obtained during initial fine-grading of the open-graded stone subbase.

dense-graded stone was produced by adding both dust and material retained on the $\frac{1}{2}$ -inch sieve to the same quarry products.

Each experimental mile contained a 3-, 5-, and 8-inch section of both open-graded and dense-graded stone subbase. During initial construction of the 3-inch subbase, a 3-inch lift was placed on the adjoining sections requiring similar material. After this lift was completed, sufficient material was placed on the remaining two sections to obtain a total compacted depth of 5 inches. Then, the third lift was placed on the remaining section to obtain the specified 8-inch depth. However, if there was considerable rain while the first lift was being placed, the subgrade became so soft that trucks could not travel on the subbase without rutting the subgrade, hence, there was usually a substantial delay before resumption of construction. Consequently, during subsequent construction, to minimize pooling of rain water in the partially completed subbase, placing of the stone was started at the top of the grade and was placed from the center toward the edges. Each section was completed to the approximate final depth before another section was started.

Initially, all lifts of the stone were placed by means of a spreader box. However, the use of a spreader box had a tendency to make the truck wheels spin and form short ruts in the subgrade. Subsequently, because of the possibility of such ruts blocking lateral drainage, the first lift of all stone subbases was spread by opening the tail gate with the truck in motion and bringing the material to the desired cross-section with a blade grader. The second and third lifts were placed with the spreader box.

A continuous series of sieve analyses was made both at the quarry and on the project during construction of a section to insure proper gradation of the stone.

A 10-ton 3-wheel roller was used for compacting each lift of both types of stone.

Compaction requirements for both types of stone specified in-place densities of 95 percent or more of the maximum dry density obtained by the Standard Method of Test for the Compaction and Density of Soils, AASHO Designation T99, except that the material passing the $\frac{3}{4}$ -inch sieve was used in the test instead of that passing the No. 4 sieve.

After the stone had been shaped and rolled to the approximate final cross-section, concrete paving forms were set and the surface of the subbase was fine graded with the same equipment used on the soil-cement subbases. Regardless of the type of cross-section, fine grading was done only on that portion of the treatment to be covered by the concrete slab.

Some segregation occurred during the placing and fine grading of the stone. There was a tendency for the coarse particles to accumulate at each end of the roll of loose



Figure 18. Texture of surface of open-graded stone subbase.

material formed ahead of the fine-grader, as shown in Figure 17. This was corrected in part by using hand labor to remix the coarse particles with the material in the central portion of the roll. In areas where segregation was not corrected during fine grading, the top portion of the subbase was torn up, remixed with a blade grader, and relaid to the proper grade. Figure 18 shows that the material at time of final rolling was not segregated.

After final rolling, in-place density tests were made in each section. Sieve analyses were made on the materials removed in making in-place density tests. Laboratory permeability tests were made on material having the coarsest and finest gradations for each of the two types of stone subbase, each sample being compacted to the average density for the corresponding grading.

Cross sections were taken on the subgrade before the stone was placed and also on the surface of the completed subbase.

Open-Graded Stone Subbase. In the first and fourth experimental miles, the open-graded stone was placed in a trench section extending 2 feet outside the proposed paving line, with lateral drains extending through the shoulder. In the second and third miles, the open-graded stone was extended through the shoulder, as shown in Figure 19.

Preliminary in-place density tests indicated that the required percentage of maximum density was not being obtained at some locations in the open-graded material. Therefore, a loaded earth scraper was substituted for the three-wheel roller. However, the

use of this equipment did not result in increased density, and tended to cause a lateral movement in the material adjacent to the wheels. Also, the tire treads left deep indentations, shown in Figure 20, which necessitated rerolling with the 3-wheel roller to obtain a smooth surface. Further investigations indicated that the 3-wheel roller had produced satisfactory density but the proper control density was not being used for comparison.

A study of data obtained in the laboratory by performing the compaction test on samples of type I-M material having different gradations indicated that the maximum dry density was related to the fraction of the material passing the No. 30 sieve. The chart shown in Figure 21 was developed for use in compaction control. It expresses the relation between laboratory maximum dry density (abscissa) and percentage passing the No. 30 sieve (ordinate) for different gradings of type I-M material used on the project.

To use the chart, the in-place density test was made, a sieve analysis was performed on the subbase material removed in the in-place density test, the percentage passing the No. 30 sieve was plotted on the chart, and the maximum dry density corresponding to this percentage was used as the standard to which the in-place dry density was compared for determination of sufficiency of subbase compaction.

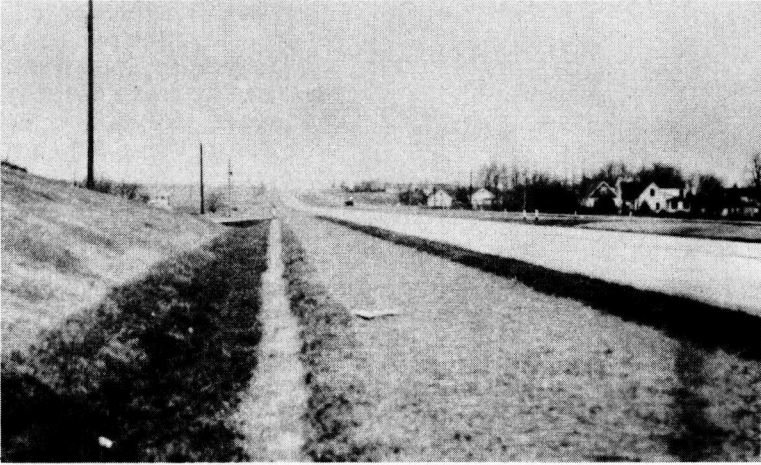

Figure 19. Completed open-graded stone section with subbase extending through shoulder.

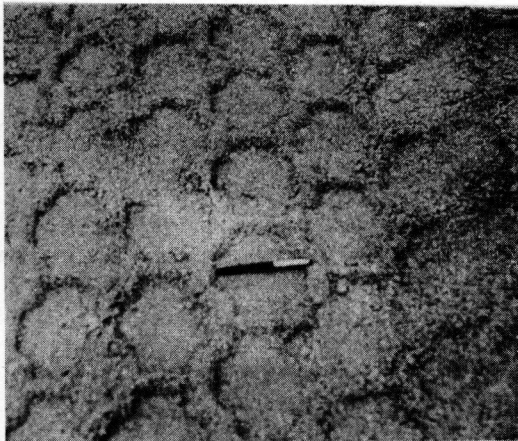

Figure 20. Condition of surface of open-graded stone subbase after rolling with a loaded earth scraper.

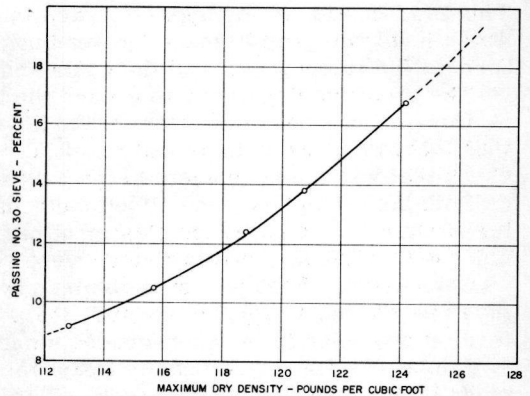

Figure 21. Relation between the percentage of the material passing the No. 30 sieve and the maximum dry density (laboratory compaction test) of the open-graded stone (type I-M). This chart was used in field compaction control.

SAMPLE NO	PERCENTAGE PASSING SIEVE		COMPACTION TEST	
	NO 30	NO 200	MAXIMUM DRY DENSITY LB /CU FT	OPTIMUM MOISTURE CONTENT PERCENT
712	9.2	1.7	112.8	9.5
725	16.8	2.4	124.2	12.7

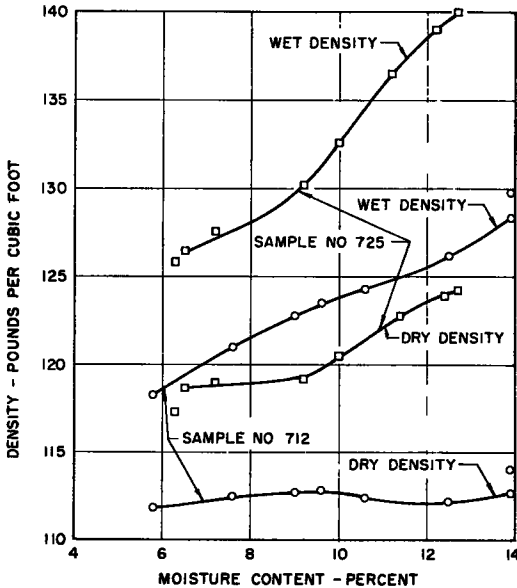

Figure 22. Moisture-density curves for open-graded (type I-M) stone.

Figure 22 shows the laboratory compaction curves for the two samples of open-graded stone used in obtaining the minimum and maximum values of maximum dry density plotted in Figure 21. As commonly found when performing the standard compaction test on open-graded or predominantly one-sized materials, the moisture-density curve for sample 712 is very irregular. There is no specific optimum moisture content, that is, a specific moisture content at which the maximum dry density is obtained. Increase in moisture content does not appreciably affect the compaction characteristics of the material, hence, the specified field compaction can be obtained at a relatively low moisture content.

It was necessary to use a new sample of stone for each point in making the laboratory compaction test because of the degradation effect of the rammer when the entire test was made on the same sample. The data in Table 8 illustrate the degradation of the open-graded material resulting from the use of one sample for the entire test.

In-place field densities in the open-graded stone were determined by means of the oil method. SAE 140 lubricating oil was used to measure the volume of the

test holes. This high viscosity oil was necessary to prevent excessive loss due to penetration.

Trial tests were made with a large rubber balloon apparatus manufactured for use in making density determinations. The expansion of the rubber pouch in the test hole was intended by the manufacturer to be obtained by means of lung pressure. The apparatus was modified so that a constant air pressure of 3 psi. could be maintained after the water from the storage cylinder had been forced into and expanded the rubber balloon. This modification of the apparatus was found necessary in order to maintain the constant water level required to make the readings accurate and to force the rubber pouch to conform to the irregularities of the walls and bottom of the test hole.

The pressure necessary to expand the balloon sufficiently to force it into the irregularities of the sides and bottom of the hole tended to enlarge the portion near the surface thus increasing the volume and resulting in erroneous readings. When this occurred a check test was made adjacent to the original hole.

Both the oil and rubber balloon methods were checked by filling test holes with plaster of paris. The hardened plaster of paris cores were removed, cleaned, and the volumes determined. These volumes were considered as the true volumes of the test holes.

Comparison of the test data obtained by all three methods indicated that the oil method was the most satisfactory and, therefore, it was used in the open-graded stone.

A total of 76 in-place density tests were made in the open-graded subbases. This number includes those made for control purposes during construction and four made in each section to determine the final density just prior to placing the concrete pavement. The final dry density values ranged

TABLE 8
DIFFERENCE IN GRADING OF SAME SAMPLE OF TYPE I-M STONE BEFORE AND AFTER LABORATORY COMPACTION TEST

Sample No.	Cumulative percentage passing sieve				
	1-inch	1/2-inch	No. 4	No. 30	No. 200
680 (before test)	100	83.2	49.9	9.4	1.6
680 (after test)	100	83.8	55.2	14.3	3.9

from 118 to 132 pcf., with an average of 124 pcf., as shown in Table 9. The relative compaction, in percent of standard determined by AASHTO Method T99-49 (modified to use the fraction smaller than $\frac{3}{4}$ inch), ranged from 95 to 107, with an average of 101 percent.

Sieve analyses were made on 46 of the samples obtained in the making of final density tests. The summary given in Table 10 shows that the average percentage passing the No. 200 sieve is slightly more than the specifications permitted. Since gradation control tests showed that the material was within the specification limits before leaving the quarry, it seems evident that the handling, blading, and rolling abraded the stone.

Subbase samples representing the coarsest and finest gradations were obtained for permeability tests. For each

TABLE 9
IN-PLACE DENSITY OF OPEN-GRADED STONE SUBBASE
(TYPE I-M)

Section No	Thickness inches	In-place dry density		Percentage of standard compaction ^a	
		Range pcf.	Average pcf.	Range	Average
1-G	3	119-126	123	95-103	100
1-H	5	124-132	128	100-107	102
1-J	8	124-128	126	102-105	104
2-K	3	118-129	122	95-104	99
2-M	5	121-129	125	99-103	101
2-L	8	121-123	122	101-104	102
3-K	3	124-127	126	99-105	102
3-M	5	120-125	124	101-103	102
3-L	8	120-124	122	100-104	102
4-G	3	119-125	121	96-106	101
4-H	5	120-126	123	98-101	100
4-J	8	121-126	124	99-102	100
All 3-in sections			123		101
All 5-in sections			125		101
All 8-in sections			124		102
All sections			124		101

^a Compaction test made on fraction passing $\frac{3}{4}$ -in sieve

TABLE 10
GRADATION OF TYPE I-M STONE (OPEN-GRADED)

Section No.	Thickness of subbase inches	Percentage passing sieve														
		1-inch			$\frac{1}{2}$ -inch			No. 4			No. 30			No. 200		
		Max.	Min.	Ave.	Max.	Min.	Ave.	Max.	Min.	Ave.	Max.	Min.	Ave.	Max.	Min.	Ave.
1-G	3	100	99	100	87	84	86	58	52	55	14	18	16	4.2	1.5	3.2
1-H	5	100	99	100	90	80	86	61	50	55	20	18	18	4.8	3.7	4.1
1-J	8	100	100	100	88	83	85	54	49	53	17	13	15	3.2	2.6	2.8
2-K	3	100	100	100	90	82	86	58	53	55	20	12	16	4.2	3.3	3.7
2-M	5	100	100	100	90	87	88	60	54	57	19	15	16	4.9	3.0	3.7
2-L	8	100	100	100	87	81	85	56	46	52	16	12	13	3.3	2.3	2.7
3-K	3	100	100	100	91	84	88	62	48	56	19	12	16	4.2	3.2	3.6
3-M	5	100	100	100	88	84	86	57	53	55	17	12	14	3.2	2.5	2.8
3-L ^a	8	100	100	100	85	83	84	52	51	52	13	13	13	3.0	2.2	2.6
4-G	3	100	100	100	89	84	87	57	53	55	16	10	14	4.2	3.7	3.6
4-H	5	100	100	100	92	85	89	63	50	55	19	14	16	4.2	2.9	3.4
4-J	8	100	100	100	93	90	91	61	58	60	17	15	16	3.0	2.1	2.5
Average of 46 samples				100			87			55			15			3.3
Specification limits				90-100			60-90			30-70			10-30			0-3

^a Two samples. Four samples were obtained from each of other sections.

of the two gradations, two samples were compacted to the average in-place density of the subbase section from which the material was obtained and a series of repetitive permeability tests were made on each of the prepared samples.

The coefficient of permeability (k) resulting from four tests on the first sample representing the approximate fine limit ranged from 14 to 15 feet per day.² Values obtained from eight tests made on the second sample representing the same gradation limit ranged from 10 to 16 feet per day, with an average of 14 feet per day.

Seven tests were made on each of the two samples approximating the coarse gradation limit. Values of k for the first sample ranged from 21 to 24 feet per day and from 19 to 21 feet per day for the second sample, with averages of 22 and 20, respectively.

²"The magnitude of the coefficient of permeability may be judged by comparing it with the rate at which water will percolate vertically into a wet soil with a deep water table. For this condition, the hydraulic gradient is unity and the coefficient of permeability is equivalent to the rate of rainfall which could be taken into the soil if the water were uniformly distributed over the surface of the soil. Thus, a soil with k=1 foot per day could transmit vertically downward a maximum rainfall of 12 inches in 24 hours." Quoted from "Highway Subdrainage," by E. S. Barber and C. L. Sawyer, Public Roads, Vol. 25, No. 12, February 1952.

TABLE 11
IN-PLACE DENSITY OF DENSE-GRADED STONE SUBBASES
(TYPE II-M)

Section No	Subbase thickness inches	In-place dry density		Percentage of stan. compaction ^a	
		Range	Average	Range	Average
		pcf.	pcf.		
1-A	3	129-134	132	96-100	98
1-B	5	134-136	135	100-101	100
1-C	8	134-137	136	100-102	101
2-A	3	130-140	134	97-104	100
2-B	5	133-139	137	99-104	102
2-C	8	134-137	135	100-102	101
3-A	3	130-139	136	97-104	101
3-B	5	133-141	136	99-105	102
3-C	8	132-135	134	98-100	100
4-A	3	133-137	135	99-102	100
4-B	5	135-138	136	100-103	101
4-C	8	134-140	138	100-104	103
All 3-inch sections			134		100
All 5-inch sections			136		101
All 8-inch sections			136		101
All sections			135		101

^a Compaction test made on fraction passing 3/4-inch sieve.

TABLE 12
GRADATION OF TYPE II-M STONE (DENSE-GRADED)

Section No.	Subbase thickness inches	Percentage passing sieve														
		1-inch			3/4-inch			No. 4			No. 30			No. 200		
		Max.	Min.	Ave.	Max.	Min.	Ave.	Max.	Min.	Ave.	Max.	Min.	Ave.	Max.	Min.	Ave.
1-A ^a	3	100	100	100	90	88	89	65	58	61	43	35	38	12.9	12.5	12.6
1-B	5	100	100	100	89	85	87	61	58	60	40	36	39	12.5	11.5	12.0
1-C	8	100	100	100	84	82	83	57	47	52	36	28	31	11.8	8.8	9.9
2-A	3	100	100	100	88	79	84	55	42	51	35	23	29	11.1	8.2	9.6
2-B	5	100	100	100	85	79	83	57	47	53	39	30	34	11.8	9.9	10.6
2-C	8	100	100	100	88	83	85	60	51	56	38	35	37	12.9	11.4	12.0
3-A	3	100	100	100	89	82	86	66	58	62	37	30	33	11.1	6.3	8.2
3-B	5	100	100	100	88	86	87	65	55	60	39	28	33	9.9	6.6	7.9
3-C	8	100	100	100	92	85	87	62	55	57	41	30	34	12.6	8.2	10.1
4-A	3	100	100	100	89	82	86	63	56	61	39	37	38	14.3	11.8	12.9
4-B	5	100	100	100	93	88	91	68	64	66	43	38	41	13.1	10.7	12.3
4-C	8	100	100	100	89	84	87	62	58	60	41	33	36	12.7	10.0	11.4
Average of 47 analyses				100			86			58			35			10.7
Specification limits				90-100			60-90			35-70			20-40			10-20

^a Three samples. Four samples from each of other sections.

subbase rain water formed pools in local low areas on the surface. These pools of water remained for several days after the storm passed.

An investigation similar to that made on the open-graded material showed that the percentage passing the No. 30 sieve, within the range encountered on the project, had no influence on the maximum density as determined by the standard compaction test. The laboratory compaction curves were normal, having a definite peak at which the maximum dry density and optimum moisture content could be determined. Also, the degradation effect of the rammer used in the compaction test was negligible.

The final dry density values ranged from 129 to 141 pcf., with an average of 135 pcf., as shown in Table 11. The relative compaction, in percent of standard determined by AASHC Method T99 (modified to use the fraction smaller than 3/4 inch), ranged from 96 to 105, with an average of 101 percent.

Both the rubber balloon method (volumeter) and the oil method were considered for making in-place density tests in this type of material. In general, the oil method was considered slightly more accurate for use in the dense-graded stone. However, the time consumed in preparing a suitable level to which to pour the oil, when balanced against the variation in data obtained by the two methods, made it more practical to use the rubber balloon method. The balloon method was checked in the same manner as

Dense-Graded Stone Subbase. Each experimental mile contained three sections of dense-graded stone subbase, having thicknesses of 3, 5, and 8 inches, respectively. The stone was placed in a trench section extending one foot outside the paving line, and no lateral drains were used.

In contrast to the open-graded subbases, after compaction of the first 3-inch lift of densely-graded stone, the loss of construction time in placing additional lifts on the 5- and 8-inch subbase sections after a rain was negligible. Inspection indicated that after a heavy rainfall very little free water collected at the bottom of the 3-inch lift, and none reached the subgrade after the 5- and 8-inch thicknesses had been placed and compacted. During one 2-day period there were approximately 3 inches of rainfall. In several locations on the rough-graded surface of the compacted

when trials were made with it in the open-graded subbase.

In addition to those made at the quarry, a total of 77 sieve analyses were made. This total includes those made for construction control and to show the final average grading of the material in place.

To determine the average grading of the material in place, 47 sieve analyses were performed on the material removed when making the final density tests. The average gradation for each section and the specification limits are given in Table 12. A few of the samples tested had slightly more than the specified 40 percent passing the No. 30 sieve and some had a deficiency of material passing the No. 200 sieve.

Gradations and densities for permeability tests were selected in the same manner as those for the open-graded subbase stone. A total of four samples was used to determine the permeability of the material representing the approximate limits of the coarse and fine variation from the general average shown in Table 12. Two samples were used to obtain data for each limit. Five tests were made on one sample and four tests on the second sample representing the approximate maximum section variation, with respect to fineness, from the general average. The coefficient of permeability (k) for the first sample ranged from 0.42 to 0.45 ft. per day and from 0.48 to 0.50 for the second sample. The averages for the respective samples were 0.43 and 0.49 ft. per day. k values for the two samples representing the maximum section variation with respect to coarseness ranged from 0.92 to 1.19 and 0.94 to 1.04 ft. per day, respectively, with average values of 1.05 and 1.00. Seven tests were made on the first sample and six on the second one.

Tests to Determine Condition of Subgrade and Subbase Prior to Paving

Before the concrete pavements were constructed, in-place California bearing ratio tests were made on the completed subgrade and subbases. Undisturbed samples for triaxial compression tests and disturbed samples for laboratory compaction and CBR tests were obtained from the completed subgrade and an in-place density test was made at each location from which an undisturbed sample was obtained. It was believed that the data obtained from these tests might be of value in a later analysis of pavement performance of the various sections.

Triaxial-Compression Tests. The soil map, Figure 10, was used as a guide in the selection of locations for obtaining undisturbed subgrade soil samples for making triaxial compression tests. The subgrade soil surveys had shown that the group index of most of the A-6 soils ranged from 8 to 12, inclusive, hence, an effort was made to select soils for sampling having group indexes in that range. Undisturbed samples of the A-6 soil were obtained from each of the four experimental miles. The A-7-6 soil in the second mile was also sampled.

These undisturbed samples, 3 inches in diameter and 7 inches long, were sent to the laboratory of the Indiana Joint Highway Research Project at Purdue University for

TABLE 13
TRIAxIAL COMPRESSION TEST DATA FOR UNDISTURBED SAMPLES OF SUBGRADE SOIL

Location Mile Station ^a No.	AASHO soil classi- fication	Max. vert.-lateral pres. for lateral pressures of.			Triaxial compression test				Subgrade modulus	Dry density	Moisture content	In-place density test ^f	
		0	7.5	15	Cohesion	Angle of internal friction	Modulus of elasticity ^b	Dry density				Moisture content	
		psi.	psi.	psi.	psi.	deg.	psi.	pci.	pcf.	percent	pcf.	percent	
1 315+30	A-6(10)	43	64	76	12	32	2120	120	118	13.6	118	13.5	
1 319+06	A-6(10)	68	71	82	24	19	1830	100	121	14.2	-	-	
2 362+72	A-6(10)	71	69 ^c	95	21	26	2780	160	121	14.5	120	16.3	
2 398+00	A-7-6(13)	36 ^d	41 ^d	38 ^d	12	22	970	50	108	20.2	111	19.6	
2 401+00	A-6(9)	90 ^e	103 ^e	95 ^e	24	27	2170	120	123	14.3	124	15.0	
3 455+95	A-6(11)	52	50	56	22	7	1710	100	114	16.0	117	13.8	
4 526+77	A-6(9)	50	90	85	20	28	1800	100	120	14.2	122	13.6	

^a All samples were obtained at the centerline of the proposed pavement.

^b Determined at strain = 2 percent of length of specimen

^c Not included in analysis because of large voids in specimen.

^d Three samples tested at each lateral pressure.

^e Two samples tested at each lateral pressure.

^f Disturbed-sample method.

TABLE 14
IN-PLACE DENSITY AND MOISTURE CONTENT OF UPPER 6 INCHES OF SUBGRADE JUST PRIOR TO CONSTRUCTION OF PAVEMENT

Thickness and type of subbase	No of tests	In-place dry density			Percentage of stan compaction			In-place			Optimum			No tests above opt. Percentage points			No. tests below opt. Percentage points		
		Max.	Min	Ave.	Max.	Min	Ave.	Max.	Min.	Ave.	Max.	Min	Ave	0-2	0 2 1	or more	0,1-2,0	2,1 or more	
		pcf.	pcf.	pcf.				pct	pct.	pct	pct	pct.	pct						
3" dense-graded	5	124	116	121.3	111	105	107.4	15.8	12.7	14.5	17.2	14.2	15.4	0	0		5	0	
5" dense-graded	5	125	111	119.4	108	101	105.9	17.2	14.3	15.7	17.2	14.0	15.4	4	0		1	0	
8" dense-graded	5	126	118	121.7	109	105	106.8	16.5	11.8	14.6	16.5	14.0	15.1	3	0		1	1	
3" open-graded	7	125	115	119.9	109	102	107.1	15.3	13.4	14.7	16.7	14.7	15.6	2	0		4	1	
5" open-graded	7	128	120	121.3	114	105	110.6	19.6	12.2	15.0	16.4	14.8	15.6	0	1		5	1	
8" open-graded	5	124	119	121.1	109	105	106.6	16.8	13.4	14.6	15.7	13.7	14.8	2	0		2	1	
3" soil-cement	6	128	109	118.4	114	94	105.1	15.7	13.1	14.6	17.2	14.0	15.7	2	0		2	2	
5" soil-cement	5	128	119	123.2	115	107	109.2	16.4	12.7	14.4	16.7	14.0	15.5	1	0		2	2	
Untreated	13	124	106	117.7	113	95	106.9	21.3	12.6	15.2	18.0	13.7	16.4	2	2		4	5	
Mile one	11	122	106	117.1	111	95	105.8	21.3	13.5	16.3	17.0	15.5	16.4	2	2		6	1	
Mile two	13	128	111	121.6	115	105	108.8	19.6	13.1	15.2	17.1	14.5	15.9	3	1		6	3	
Mile three	12	124	114	118.6	112	102	106.9	16.8	13.8	15.2	18.0	14.7	16.4	4	0		4	4	
Mile four	22	128	109	121.4	114	94	107.1	15.3	11.8	13.6	18.0	13.7	14.6	7	0		10	5	
Entire project	58	128	106	120.0	115	94	107.2	21.3	11.8	14.8	18.0	13.7	15.6	16	3		26	13	

determination of triaxial strength. The test data are summarized in Table 13.

The ranges in soil strength characteristics were as follows: cohesion - 12 to 24 psi. ; angle of internal friction - 7 to 32 degrees; modulus of elasticity - 970 to 2,780 psi. ; and subgrade modulus - 50 to 160 psi. per inch.

The data for "maximum vertical minus lateral pressure" given in Table 13, were used in plotting Mohr stress circles, from which the cohesion and angle of internal friction for the soils were determined.

The modulus of elasticity was determined from a secant line drawn between 0 and 2 percent strain on the stress-strain curve.

The subgrade modulus was computed by using Burmister's equation (6) for rigid pavements, which is

$$k = \frac{E_2}{1.18rF_w}$$

in which E_2 is the modulus of elasticity of the subgrade, r is the radius of the bearing plate in inches, and F_w is the settlement coefficient. The values of subgrade modulus in Table 13 are based on a 30-in. diameter plate and a settlement coefficient, F_w , of 1.0 (no subbase).

Although the A-7-6(13) soil had the lowest cohesion, modulus of elasticity and dry density, and the highest moisture content, there was no consistent relationship shown between group index and strength characteristics, density, or moisture content of the soils. Some of the specimens had surface cavities, caused by the extraction of pebbles during sampling or preparation of the specimen for testing, which reduced the cross-sectional area of such specimens and probably resulted in erroneous test data. However, when such cavities were extensive, the test data were omitted in the computation of strength characteristics.

Attention is called to the close agreement, shown in Table 13, between the densities and moisture contents obtained from laboratory tests of the undisturbed samples and those determined in-place by the disturbed sample method.

In-Place Density. At least one in-place density test was made in the subgrade of each section just prior to paving. The tests were made in subbase sections 1 to 10 days before the pavement was placed for all except the soil-cement sections. For all except one of the soil-cement sections, the interval was 14 to 21 days. The interval was one day in section 1-E. The data for the untreated sections are the same as those given in Table 5. A summary of the test data for all sections is given in Table 14.

The dry density varied from 106 to 128 pcf., with an average of 120 pcf. The average relative compaction for all sections was 107 percent, and was slightly higher, 109 percent, in the second experimental mile than in the other three miles.

With one exception, the tests showed the relative compaction of the upper 6 inches of the subgrade to be at least 95 percent and was 101 percent or greater in all sections except parts of 1-D (untreated) and 4-E (3-in. soil-cement subbase) just prior to paving. One test in sections 1-D and 4-E showed a relative compaction of 95 and 94 percent, respectively, but tests in other portions of the same sections just prior to paving, as well

as just prior to placement of the subbase on section 4-E, indicated a relative compaction of 101 percent or greater.

These high subgrade density values are due not only to the thorough compaction during initial construction of the subgrade but also to the subsequent manipulation necessary to satisfy moisture and density requirements at the time of placing the subbase and to the additional compaction obtained during construction of the subbases. The average in-place dry density was 4 pcf. greater just prior to paving than it was just prior to construction of the subbases.

For the 58 in-place density tests, 16 moisture contents were within 2 percentage points above the respective optimum moisture contents, three were more than 2 points above, 26 were within 2 points below, and 13 were more than 2 percentage points below optimum moisture content. The moisture contents of the subgrades ranged from 3.3 percentage points below optimum to 3.2 percentage points above optimum for the subbase sections. These data for the subbase sections indicate a lesser range in moisture content from the optimum than before the subbases were placed but the percentage of test results below optimum was practically unchanged. The drier soils probably acquired some moisture either from a surface source or by capillary action.

In-Place CBR Tests. At least one set of in-place CBR tests was made in each section just prior to pavement construction. One test in each set was made on the subbase surface and another on the surface of the subgrade.

Table 15 shows the range in in-place CBR values for the subbases. The values for the dense-graded stone ranged from 8 to 45, with an average of 25 and those for the open-graded stone ranged from 4 to 20, with an average of 9.

The low moisture content of the subbases may be partially responsible for these relatively low CBR values. It is noted that the in-place moisture content ranged from 1.1 to 4.9 percent for the dense-graded stone and from 2.3 to 4.9 percent for the open-graded stone. Table 17 shows that the optimum moisture contents for average gradations of the two types of stone were 8 and 10 percent, respectively.

It does not appear that the relatively low CBR values can be attributed to insufficient compaction of the subbases. The minimum in-place dry density for the dense-graded stone, determined at the CBR test site, was 134 pcf., which is the same density used as a control standard during compaction. For the open-graded stone subbases, the in-place dry density ranged from 118 to 129 pcf., while the range for compaction control was 116 to 128 pcf.

For the soil-cement subbases, CBR values for the tests made within the capacity of the testing apparatus ranged from 168 to 227.

The in-place CBR values for the subgrade ranged from 2 to 46, with an average of

TABLE 15
IN-PLACE CBR VALUES AND RELATED DENSITIES AND MOISTURE CONTENTS OF SUBBASES^a

Thickness and type of subbase	No. of tests	In-place CBR value		In-place Dry density		Dry density Compaction control		Moisture content (CBR test) ^b	
		Range	Average	Range	Average	Range	Average	Range	Average
		percent	percent	pcf.	pcf.	pcf.	pcf.	percent	percent
3-inch dense-graded	6	8-34	22	134-138	135	134	134	1.1-4.9	2.9
5-inch dense-graded	6	17-45	28	135-136	136	134	134	2.4-4.8	3.6
8-inch dense-graded	6	18-30	23	134-140	137	134	134	2.8-4.1	3.3
All dense-graded	18	8-45	25	134-140	136	134	134	1.1-4.9	3.3
3-inch open-graded (tr.) ^c	4	6-18	10	119-126	123	116-123	120	2.9-4.9	4.0
3-inch open-graded (sh.) ^d	2	6	6	120-126	123	124-127	120	2.9-3.6	3.2
5-inch open-graded (tr.)	4	4-20	10	120-129	124	121-128	124	4.1-4.6	4.4
5-inch open-graded (sh.)	2	4-5	5	123-124	124	122-125	123	2.5-2.7	2.6
8-inch open-graded (tr.)	4	8-20	12	118-125	122	122-124	123	3.4-3.6	3.5
8-inch open-graded (sh.)	2	6-8	7	120-124	122	120-123	122	2.3-4.1	3.2
All open-graded	18	4-20	9	118-129	123	116-128	123	2.3-4.9	3.7
3-inch soil-cement	5	188-227	209	91-102	99	99-103	101	17.2-24.6	20.6
5-inch soil-cement	4	168-214	199	94-102	98	94-106	100	18.7-24.4	20.5
All soil-cement	9	168-227	204	91-102	98	94-106	101	17.2-24.6	20.6

^aAll tests were made just prior to paving.

^bIn some CBR tests, moisture content was not determined so value for adjacent in-place density test was used.

^c"(tr.)" - Trench-section subbase.

^d"(sh.)" - Subbase continuous through shoulders.

TABLE 16
IN-PLACE CBR VALUES AND RELATED DENSITIES AND MOISTURE CONTENTS OF A-6 SUBGRADE SOILS,
ARRANGED ACCORDING TO GROUP INDEXES

AASHO group index	No. of tests	In-place CBR		In-place density		Moisture content			
		Range	Average	Range	Average	CBR test ^a		Optimum ^b	
		percent	percent	pcf.	pcf.	Range	Average	Range	Average
7	1	18	18	125	125	14, 3	14, 3	14, 2	14, 2
8	10	3-46	21	115-126	121	7, 6-18, 4	13, 7	13, 7-14, 0	13, 9
9	8	2-33	13	119-122	121	12, 3-19, 3	15, 6	14, 2-16, 7	15, 1
10	24	3-38	14	111-128	121	12, 7-18, 2	15, 0	14, 5-17, 0	15, 8
11	4	8-31	18	116-120	118	13, 6-15, 9	15, 0	17, 2	17, 2
12	1	7	7	115	115	16, 3	16, 3	18, 0	19, 0
All tests	48	2, 46	15	111-128	121	7, 6-19, 3	14, 9	13, 7-18, 0	15, 4

^a In some CBR tests, moisture content was not determined so the value for adjacent in-place density test was used.
^b Standard AASHO compaction test.

15, as shown in Table 16. Although not shown in the table, the CBR values for the subgrade under the dense-graded stone ranged from 3 to 29 and from 2 to 15 under the open-graded stone, while the subgrades under the soil-cement subbases ranged from 8 to 38.

Table 16 shows no definite tendency for the CBR to vary inversely with the group index of the subgrade soils. However, this failure may be due to variations in moisture content and density of the soil. The low CBR values were generally obtained where the moisture content was near or above optimum.

For example, the CBR value of 2 corresponds to a subgrade moisture content of 17.6 percent, or about 2 percentage points above optimum, while the CBR value of 46 corresponds to a moisture content of 7.6 percent. Figure 23 shows their is a tendency for the CBR to increase with decrease in moisture content for the A-6(10) subgrade soils. The same figure shows that the variation in CBR with respect to density of the A-6(10) soil is quite erratic.

Typical in-place CBR curves are shown in Figure 24 and a view of the in-place CBR testing equipment in Figure 25.

Laboratory CBR Tests. Samples of subgrade soil for laboratory CBR tests were obtained at eight locations. The identification test data showed similar characteristics for several of the soils, so in three instances two soils were mixed to make composite samples. Consequently, laboratory CBR tests were made on five instead of the original eight samples.

One laboratory CBR test was made on a sample of open-graded crushed stone representing the average grading of all sections having this type of subbase. Another test was made on a sample representing the average grading of all sections of dense-graded crushed stone.

The laboratory CBR samples were 6.19 inches in diameter and 5 inches long. A 12.7-pound hammer having a striking face of 7.06 square inches was used to compact the samples in three layers, using 25 blows for each layer and a height of fall of 12

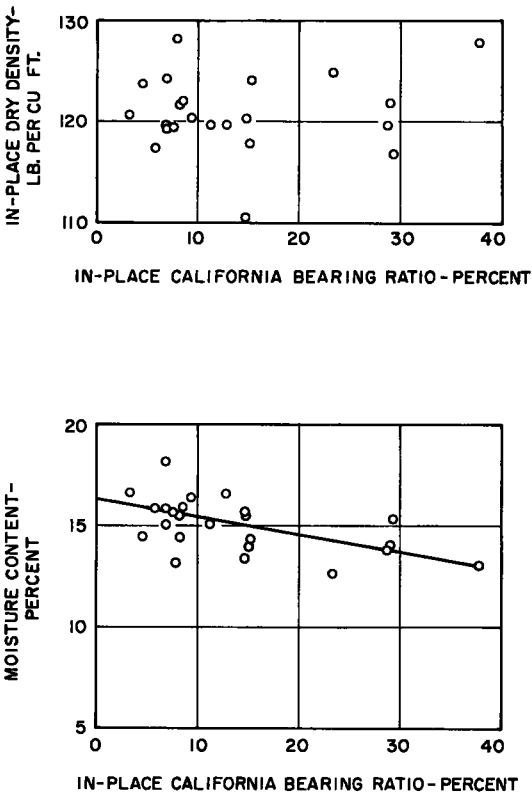

Figure 23. Relationship of in-place California bearing ratio to moisture content and in-place dry density of A-6(10) subgrade soil.

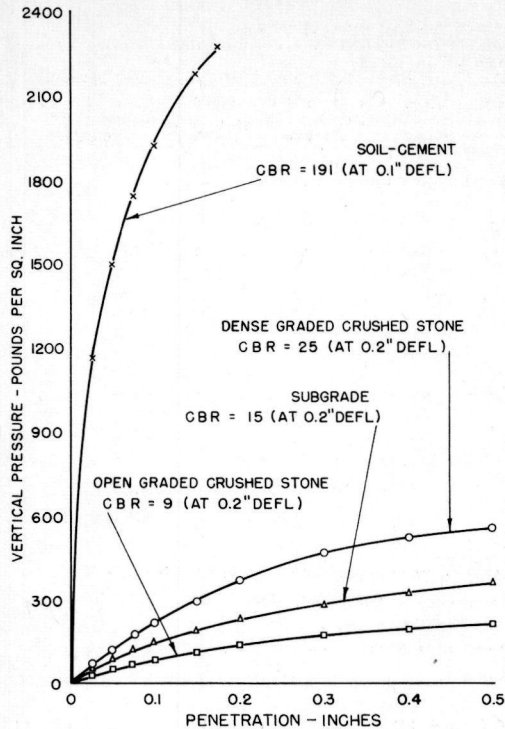

Figure 24. Typical in-place California bearing ratio curves.

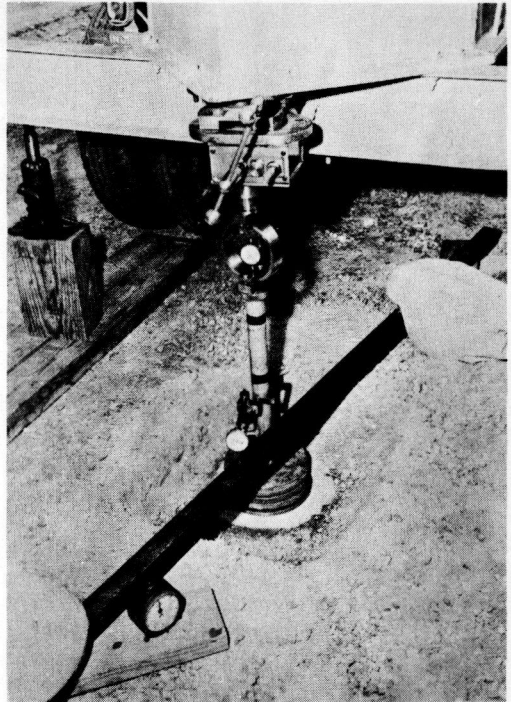

Figure 25. In-place CBR apparatus just prior to start of test.

inches. By using this compactive effort, the maximum dry unit weight and optimum moisture content obtained for a soil was the same as obtained in the standard AASHTO compaction test.³ In using this equipment to obtain compaction data equivalent to that obtained in the modified compaction test,⁴ the samples were compacted in five layers, using 50 blows per layer and a height of fall of 18 inches.

Table 17 gives the laboratory CBR data. Data for in-place CBR tests made at some of the same localities from which the laboratory CBR samples were obtained are also given in the table.

The CBR values ranged from 4 to 6 for soil samples prepared by the equivalent standard compaction procedure, the low value being obtained on soil with a group index of 11 while the high value was obtained on soil with a group index of 10. The A-6(12) soil had a CBR of 5. The CBR values ranged from 11 to 23 for soil samples prepared by the equivalent modified compaction procedure, the lowest value being obtained on the A-6(12) soil and the highest value on the A-6(9) soil. These data do not show a definite relationship between CBR values and group indexes.

For the tests made at the same locations from which the laboratory samples were obtained, the in-place CBR values ranged from 8 for an A-6(11) soil to 29 for an A-6(10) soil. Although the in-place dry density conformed more closely to the maximum density obtained by the modified than by the standard laboratory compaction procedure, there are insufficient data to permit a comparison of in-place and laboratory CBR values.

CBR values of 57 and 91 were obtained on the open-graded and dense-graded subbase materials, respectively, when prepared by the equivalent standard compaction procedure. The open-graded and dense-graded subbase materials, prepared by the equivalent modi-

³ In AASHTO Method T 99, the $\frac{1}{30}$ cubic foot specimen is compacted in 3 layers, using 25 blows per layer, and a $5\frac{1}{2}$ -pound hammer, dropped from a height of 12 inches.

⁴ In the modified compaction test, the $\frac{1}{30}$ cubic foot specimen is compacted in 5 layers, using 25 blows per layer, and a 10-pound hammer, dropped from a height of 18 inches.

TABLE 17
COMPARISON OF IN-PLACE AND LABORATORY CALIFORNIA BEARING RATIO TEST DATA

Test or sample location and data identification	Subgrade								Subbase	
	Series No. 1	Series No. 2 ^a	Series No. 3 ^a	Series No. 4 ^a	Series No. 5	Series No. 6	Series No. 7	b c	b c	
Section No.	2-M	3-K	4-D	2-D	3-D	1-D	1-D	2-M		
Type of subbase	Open-graded stone	Open-graded stone	None	None	None	None	None	Open-graded stone	Open-graded stone (I-M) ^b	Dense-graded stone (II-M) ^b
Location of laboratory CBR sample	401+00, E	428+00, E	490+48, E	362+72, E	455+95, E	315+30, E	319+06, E	396+00, E		
AASHO classification of laboratory CBR sample	A-8(8)	A-8(9)	A-8(9)	A-8(10)	A-8(10)	A-8(11)	A-8(11)	A-8(12)	-	-
Dry density, pcf.										
Field in-place	120	120	122	120	-	118	-	111	124	135
Maximum-										
Standard compaction test ^d	112	112	110	109	108	106	109	102	121	134
Modified compaction test ^e	124	124	117	121	120	120	120	117	132	135
Laboratory CBR sample, initial										
Standard compaction test ^d	112	114	114	110	110	109	109	102	120	134
Modified compaction test ^e	125	124	124	124	124	122	122	119	131	136
Moisture content, percent										
Field in-place density test	15	15	13	16	-	14	-	20	-	-
Field in-place CBR test	-	-	-	14	-	-	14	-	-	-
Optimum -										
Standard compaction test ^d	16	15	17	17	17	16	17	16	10	8
Modified compaction test ^e	12	11	15	13	13	13	13	14	8	6
Laboratory CBR sample, end of test										
Standard compaction test ^d	16	16	18	18	18	18	18	23	6	9
Modified compaction test ^e	13	14	17	17	16	16	19	19	7	12
CBR, percent										
Field in-place	-	-	22	29	-	-	8	-	4-20 ^c	8-45 ^c
Laboratory -										
Standard compaction test ^d	5	5	6	6	4	4	5	5	57	91
Modified compaction test ^e	13	23	20	20	12	12	11	11	157	181

^a In each of three series, soil having same AASHO classification was obtained from two locations and combined into one sample for laboratory CBR tests

^b Laboratory CBR tests made on composite samples representing approximate average grading of indicated type of stone.

^c Range of in-place CBR values shown for tests in several sections

^d AASHO Designation T 99.

^e Using 1/30 cu. ft. mold, soil compacted in 5 layers with 25 blows per layer by means of 10-lb. hammer dropped from height of 18 inches.

^f Sample compacted at optimum moisture content as determined in standard compaction test.

^g Sample compacted at optimum moisture content as determined in modified compaction test.

fied compaction procedure, had CBR values of 157 and 181, respectively.

As previously stated, the average in-place CBR value for the open-graded stone was 9, while that of the dense-graded stone was 25. These low in-place CBR values obtained on the subbase compared to the laboratory values may be partially due to the fact that the subbases were compacted with a smooth-wheel roller, whereas the laboratory samples were compacted by a dynamic process. Also, it is possible that the lateral restraint of the mold in the laboratory CBR test affected the test value.

No laboratory CBR tests were made on the soil-cement mixture.

Paving

The materials used in the concrete pavement conformed to the 1946 Indiana specifications. Two sizes of coarse aggregate were used; the large size was crushed limestone obtained from Thornton, Illinois and the smaller size was gravel obtained from a terrace at Lafayette, Indiana. The fine aggregate was obtained from the same terrace as the gravel.

Construction of both plain and reinforced concrete pavement was in accordance with the Indiana standard specifications. At least one thickness core was obtained from each section. These 55 cores taken from the planned 8-in. thickness of the pavement, ranged in thickness from 7.6 to 8.8 inches, with 7 being less than 8.0 inches. No cores were obtained from the thickened-edge portion of the pavement.

In general, two beams were made for each experimental section for determination of the flexural strength of the concrete. A summary of the flexural strength data is given in Table 18. The minimum and maximum 7-day flexural strengths were 450 and 809 psi., respectively, while

TABLE 18
FLEXURAL STRENGTH OF CONCRETE BEAMS

Subbase thickness and type	Flexural strength					
	7-day			28-day		
	Max.	Min.	Ave.	Max.	Min.	Ave.
	psi.			psi.		
3" dense-graded	727	591	643	880	634	797
5" dense-graded	791	522	605	872	729	759
8" dense-graded	701	513	614	831	678	773
3" open-graded	662	532	600	833	720	767
5" open-graded	809	525	652	990	645	843
8" open-graded	784	530	646	930	599	784
3" soil-cement	691	477	592	822	674	721
5" soil-cement	736	450	625	872	618	744
Untreated	704	525	591	870	629	761
Mile No. 1	791	477	634	916	618	800
Mile No. 2	809	513	625	990	599	763
Mile No. 3	727	522	593	880	629	761
Mile No. 4	722	450	622	978	624	764
All sections	809	450	619	990	599	776

TABLE 19
SUMMARY OF CONCRETE PAVING DATA

Mile No.	Cement content			Water content			Air content		
	Max.	Min.	Ave.	Max.	Min.	Ave.	Max.	Min.	Ave.
	Bbl. per cu. yd.			Gal. per sack cement			Percent		
1	1.505	1.496	1.500	5.50	5.07	5.29	4.65	2.95	3.72
2	1.505	1.493	1.501	5.59	4.93	5.20	4.75	2.95	3.68
3	1.504	1.491	1.500	5.54	5.04	5.21	3.75	2.85	3.31
4	1.510	1.490	1.500	5.61	5.09	5.30	3.70	2.65	3.22
All sections			1.500			5.20			3.48

the average for all sections was 619 psi. Minimum, maximum, and average 28-day flexural strengths were 599, 990, and 776 psi., respectively.

Tests for the determination of yield, slump, water-cement ratio and air entrainment were made periodically to control the quality of the concrete mixture. Table 19 shows that the cement yield varied but slightly from the average of 1.50 barrels per cu. yd. of concrete. The average water-cement ratio was 5.2 gallons of water per sack of

TABLE 20
TYPE TOTALS FOR MANUAL COUNTS OF VEHICLES FOR FOUR 7-DAY PERIODS EACH YEAR, 1950-1953

Year	Month	Passenger cars	Single-unit trucks		Truck combinations ^a	Buses (school other)	Total vehicles
			Under 1½ tons, panel	All pickup others			
1950	January	9,772	527	806	3,554	38	14,697
	April	13,779	743	897	3,604	65	19,088
	July	18,153	793	1,144	4,076	74	24,240
	October	16,199	747	987	4,167	77	22,177
	Total	57,903	2,810	3,834	15,401	254	80,202
	Ave. daily	2,068	100	137	550	9	2,864
1951	January	10,606	604	776	3,763	54	15,803
	April-May	15,077	794	869	3,806	72	20,618
	August	20,965	1,075	959	3,729	89	26,817
	November	15,999	855	842	4,073	92	21,861
	Total	62,647	3,328	3,446	15,371	307	85,099
	Ave. daily	2,237	119	123	549	11	3,039
1952	January	12,394	807	774	3,545	51	17,571
	April	17,747	882	916	3,759	76	23,380
	July-Aug.	22,561	981	1,012	3,809	98	28,461
	October	19,318	871	1,057	4,498	106	25,850
	Total	72,020	3,541	3,759	15,611	331	95,262
	Ave. daily	2,572	126	134	558	12	3,402
1953	Jan. -Feb.	14,606	721	826	4,183	82	20,418
	April	16,706	805	1,014	4,299	101	22,925
	July-Aug.	24,458	969	975	4,191	95	30,688
	Oct. -Nov.	19,143	816	1,001	4,504	103	25,567
	Total	74,913	3,311	3,816	17,177	381	99,598
	Ave. daily	2,675	118	136	613	14	3,557

^a Includes tractor-truck semitrailers, single-unit trucks and trailers, and tractor-truck semitrailer and trailer.

cement. The air content varied from 2.7 to 4.8 percent, with an average of 3.5 percent.

Following a heavy rain, concrete batch hauling on the east shoulder during paving operations on the 3- and 5-in. full-width open-graded stone subbases of the second mile caused deep rutting and mixing of the soil with the stone. In order to re-establish drainage, the mixture of stone and soil was removed and the damaged portions rebuilt.

TRAFFIC SURVEYS

Traffic surveys have been made periodically on the project to classify vehicles by types and weights and to determine variations in traffic volume. A speed and placement study was made in 1950.

Four 7-day manual classification counts, seasonally spaced, were made each year from 1950 through 1953. Vehicles were classified as follows: (1) passenger cars; (2) single unit trucks, under 1½ tons, panel and pickup, two-axle, single-tired, two-axle, dual-tired, three-axle; (3) tractor-truck semitrailer; three, four, five, and six axles separately classified; (4) single-unit trucks and trailers; four and five axles separately classified; (5) tractor-truck semitrailer and trailer; five, six, and seven axles separately classified; and (6) busses (school and other).

Table 20 gives a general summary of the data for the 7-day manual classification counts made in 1950-1953.

Data for the traffic counting periods show that the daily average number of vehicles increased each year, being 2,864, 3,039, 3,402, and 3,557 in 1950, 1951, 1952, and 1953, respectively. This increase was primarily in passenger car traffic, for which the average daily traffic was 2,068, 2,237, 2,572, and 2,675 for the four successive years. The number of small single-unit trucks (under 1½-ton) increased from 100 in 1950 to 126 in 1952 but decreased to 118 in 1953. There was no significant change in number of heavier single-unit trucks, the daily averages being 137, 123, 134, and 136 for the four successive years. The number of truck combinations showed only slight change in the first three years, the daily average being 550, 549, and 558 successively, but increased to 613 in 1953. The daily average number of busses increased from 9 in 1950 to 14 in 1953.

Each day of the traffic counting periods was divided into three 8-hr. shifts, midnight to 8 A. M., 8 A. M. to 4 P. M., and 4 P. M. to midnight.

Eliminating panels and pickups and other 2-axle single-tired vehicles which ordinarily do not have heavy axle loads, the most truck traffic was from 4 P. M. to midnight, exception Saturday. Also, the least number of trucks counted was on Saturdays and Sundays.

Table 21 shows the minimum average time interval in minutes between trucks during the 8-hr. periods of greatest truck traffic in the four manual traffic counts each year during the 1950-53 period. These data do not include passenger cars, single-unit trucks under 1½ tons, other 2-axle single-tired trucks nor buses. However, the 2-axle, dual-tired, single-unit trucks are included since the axle loads in this group range up to 23,999 lb.

The data in this table show that during all traffic counting periods the peak volume was 455 trucks in the classifications included in the tabulation, during an 8-hr. shift. The minimum average time interval between such trucks in this period was 1.05 minutes.

As stated previously, trucks were weighed on pit scales located about 5 miles north of the project. In the first two weighing periods in 1950, vehicles were weighed 8 hours each day for three weeks, a different 8-hr. period being used each week. The remaining two weighing periods in 1950 were less extensive and were conducted in conjunction with the placement studies. Trucks were weighed on three days in the third period and on six days in the fourth period, but the weighing was done only during 8 hours each day.

In the first cycle of 1951, the weighing procedure was similar to that in the first two periods of 1950, but was scheduled for late April and early May. The second weighing period in 1951 and those in subsequent years were of three days' duration, and trucks were weighed only from 4 P. M. to midnight of each day. Currently, there are only two 3-day weighing periods each year, normally in April and October. These two weighing periods occur at approximately the same times as the second and fourth manual traffic counts.

TABLE 21
MINIMUM AVERAGE TIME INTERVALS BETWEEN TRUCKS^a DURING PERIODS
OF HIGHEST TRUCK TRAFFIC

Year	Month ^b	Volume of truck traffic during 8-hr. period of greatest intensity ^c			Minimum average time interval between trucks for:		
		Max.	Min.	Ave.	Max. peak	5-day average (Mon. - Fri.)	7-day average ^d
				minutes	minutes	minutes	
1950	January	360	334	350	1.33	1.37	1.63 ^e
Do.	April	380	315	349	1.26	1.37	1.66 ^e
Do.	July	416	379	397	1.15	1.21	1.46 ^e
Do.	October	428	382	409	1.12	1.17	1.39 ^f
1951	January	410	255	355	1.17	1.35	1.62 ^f
Do.	April-May	418	328	382	1.15	1.26	1.54 ^f
Do.	August	414	349	383	1.16	1.25	1.54 ^f
Do.	November	396	344	374	1.21	1.28	1.54 ^e
1952	January	394	325	363	1.22	1.32	1.63 ^f
Do.	April	416	355	387	1.15	1.24	1.57 ^e
Do.	July-Aug.	411	357	385	1.17	1.24	1.55 ^e
Do.	October	455	398	417	1.05	1.15	1.39 ^f
1953	Jan. -Feb.	395	361	379	1.22	1.27	1.52 ^e
Do.	April	434	395	414	1.11	1.16	1.44 ^e
Do.	July-Aug.	426	372	394	1.13	1.22	1.50 ^e
Do.	Oct. -Nov.	450	412	428	1.07	1.12	1.36 ^f

^a Excluded from data are passenger cars, buses, single-unit trucks under 1½ tons and other 2-axle single-tired trucks.

^b Month during which the 7-day manual traffic count was made.

^c 4 p. m. to midnight, Monday to Friday, inclusive.

^d The maximum truck traffic on Saturdays, regardless of the 8-hour period in which it occurred, was included in computations for the 7-day average for the period from 4 p. m. to midnight.

^e Peak volume for Saturday - between midnight and 8 a. m.

^f Peak volume for Saturday - between 8 a. m. and 4 p. m.

Table 22 shows the number of trucks counted and the number of empty and loaded trucks weighed during the four weighing periods of 1950. The trucks which were not weighed were mostly in the lighter classifications.

Tables 23 and 24 show, by weight groups, the estimated average daily number of single axles over 10,000 lb. and tandem axles over 16,000 lb. (total for both axles), respectively, passing over the experimental project during 1950-1953. These tabulations are based on the data obtained during the weighing periods and from the automatic traffic recorder, hence, the indicated weight data have been expanded by class so that the frequencies are for all trucks passing, whether or not they were weighed.

TABLE 22
COMPARISON OF NUMBER OF TRUCKS
COUNTED AND NUMBER OF TRUCKS
WEIGHED DURING THE FOUR WEIGHING
CYCLES OF 1950.

Weighing cycle	No. of loaded trucks weighed	No. of empty trucks weighed	Total No. of trucks weighed	Total No. of trucks counted
First	3,091	493	3,584	4,502
Second	3,735	682	4,417	5,400
Third	732	159	891	998
Fourth	1,470	291	1,761	2,027
Totals	9,028	1,625	10,653	12,927

TABLE 23
AVERAGE NUMBER OF SINGLE AXLE LOADS OF 10,000 LB. AND OVER PER DAY OF EACH MONTH FOR 1950-1953.
TABULATED IN VARIOUS WEIGHT GROUPS

Month	Year	Average number of single axle loads per day by weight groups												
		10,000-11,900	12,000-13,900	14,000-15,900	16,000-16,900	17,000-18,000	18,100-18,900	19,000-19,900	20,000-21,900	22,000-23,900	24,000-25,900	26,000-32,000	10,000-32,000	18,100-32,000
		lb.	lb.	lb.	lb.	lb.	lb.	lb.	lb.	lb.	lb.	lb.	lb.	lb.
January	1950	70.8	85.3	168.2	129.7	115.1	75.5	37.0	12.9	2.9	0.6	0.0	738.0	128.9
	1951	73.9	90.2	182.4	138.7	166.4	81.7	40.6	14.4	3.6	0.6	0.0	792.5	140.9
	1952	61.0	74.7	155.7	115.4	142.0	68.9	35.2	12.5	3.4	0.5	0.0	669.3	120.5
	1953	65.3	99.6	159.0	115.8	145.6	65.6	21.3	6.2	0.6	0.5	0.2	679.7	94.4
February	1950	78.3	94.1	186.3	143.6	171.6	83.4	40.9	14.2	3.3	0.6	0.0	816.3	142.4
	1951	73.9	90.1	182.4	138.7	166.4	81.8	40.7	14.4	3.6	0.6	0.0	792.6	141.0
	1952	68.8	84.3	177.3	130.3	159.8	77.7	39.7	14.1	3.8	0.5	0.0	756.3	135.8
	1953	76.6	116.9	186.0	135.6	170.5	77.1	24.9	7.2	0.8	0.6	0.3	796.4	110.8
March	1950	66.9	97.1	139.8	97.2	128.8	67.8	21.4	5.5	0.6	0.0	0.0	625.0	95.3
	1951	75.1	109.8	158.2	110.2	148.7	78.6	24.9	6.7	0.7	0.0	0.0	712.9	110.9
	1952	65.4	95.7	141.6	98.6	132.5	69.3	22.2	6.0	0.7	0.0	0.0	631.8	98.1
	1953	74.3	112.5	178.7	129.8	162.0	73.7	23.6	6.9	0.7	0.6	0.3	763.1	105.9
April	1950	74.0	107.7	155.4	107.9	142.5	74.9	23.7	6.1	0.7	0.0	0.0	693.0	105.5
	1951	76.0	111.1	160.2	111.5	150.6	79.6	25.2	6.8	0.8	0.0	0.0	721.7	112.4
	1952	68.6	101.3	151.2	105.0	138.8	73.2	23.2	6.3	3.1	0.0	0.0	670.7	105.8
	1953	80.2	121.3	191.7	139.7	174.7	79.6	25.5	7.5	0.8	0.6	0.3	821.9	114.3
May	1950	87.2	127.3	183.2	127.1	168.0	88.6	27.9	7.2	0.8	0.0	0.0	817.5	124.6
	1951	86.1	125.9	181.4	126.2	170.5	90.3	28.5	7.7	0.8	0.0	0.0	817.4	127.3
	1952	77.8	114.0	168.8	117.4	157.5	82.5	26.3	7.1	0.8	0.0	0.0	752.2	116.7
	1953	87.9	132.8	210.2	153.0	191.3	87.2	27.9	8.2	0.9	0.7	0.3	900.4	125.2
June	1950	65.1	121.8	165.8	114.4	163.3	84.9	21.0	13.5	0.7	0.9	0.0	751.4	121.0
	1951	55.3	105.8	139.9	100.4	143.9	72.5	18.8	12.3	0.7	0.7	0.0	650.3	105.0
	1952	55.2	105.4	139.6	101.7	143.6	71.8	18.9	12.9	0.8	0.7	0.0	650.6	105.0
	1953	65.4	99.4	159.6	116.0	144.6	65.6	21.0	6.2	0.7	0.5	0.2	679.1	94.2
July	1950	72.0	134.8	183.1	126.5	180.4	94.0	23.3	15.0	0.7	1.0	0.0	830.7	133.9
	1951	60.9	117.1	153.7	110.7	158.8	80.1	20.8	13.7	0.8	0.8	0.0	717.4	116.1
	1952	62.2	112.3	156.1	113.8	161.1	80.9	21.2	14.5	0.9	0.7	0.0	723.8	118.3
	1953	75.0	113.8	182.4	132.5	165.3	75.1	24.1	7.1	0.7	0.6	0.3	776.9	107.9
August	1950	81.8	152.9	208.2	143.8	204.4	106.7	26.4	17.0	0.8	1.1	0.0	943.0	152.0
	1951	66.8	128.2	169.0	121.8	174.1	87.7	22.9	15.0	0.9	0.8	0.0	787.3	127.3
	1952	67.3	128.5	169.6	123.5	174.4	87.5	23.0	15.7	0.9	0.8	0.0	791.3	128.0
	1953	79.0	119.8	192.5	139.8	174.1	79.1	25.3	7.5	0.8	0.6	0.3	818.7	113.5
September	1950	87.0	156.7	199.0	154.1	222.0	91.6	37.2	7.0	1.2	0.6	0.0	956.3	137.5
	1951	85.6	152.7	211.5	161.9	226.3	93.3	37.1	6.9	1.2	0.7	0.0	977.2	139.3
	1952	81.3	145.4	204.7	156.7	218.9	90.9	35.9	6.6	1.3	0.7	0.0	942.4	135.5
	1953	93.4	142.5	229.7	166.9	208.0	94.4	30.3	9.0	0.9	0.7	0.3	976.1	135.6
October	1950	74.2	133.5	170.7	131.9	189.1	77.9	31.7	5.9	1.0	0.5	0.0	816.5	117.0
	1951	72.4	129.2	178.7	136.7	191.3	79.0	31.4	5.9	1.1	0.6	0.0	826.1	117.9
	1952	70.7	126.6	178.5	136.5	190.5	79.2	31.3	5.8	1.2	0.6	0.0	821.0	118.1
	1953	82.2	125.2	202.5	147.1	183.0	82.9	26.6	7.9	0.8	0.6	0.3	859.2	119.2
November	1950	66.2	119.2	152.8	118.0	168.9	69.6	28.3	5.3	0.9	0.4	0.0	729.6	104.5
	1951	63.7	113.8	157.2	120.3	168.6	69.6	27.7	5.2	0.9	0.5	0.0	727.5	103.9
	1952	61.1	109.8	154.8	118.1	165.0	68.3	27.1	5.0	1.0	0.6	0.0	710.9	102.1
	1953	69.1	105.4	170.2	123.7	154.0	69.8	22.4	6.7	0.7	0.6	0.2	722.8	100.4
December	1950	84.4	101.5	201.0	155.1	184.8	89.9	44.0	15.4	3.5	0.7	0.0	880.5	153.5
	1951	74.6	91.1	184.2	140.1	168.1	82.6	41.1	14.5	3.6	0.6	0.0	800.7	142.6
	1952	67.8	83.1	173.2	128.5	157.5	76.6	39.1	13.9	3.7	0.5	0.0	743.9	133.9
	1953	75.2	114.7	182.7	133.1	167.4	75.5	24.4	7.1	0.7	0.6	0.3	781.7	108.6
Daily Ave.	1950	75.7	119.4	176.1	129.1	173.2	83.8	30.2	10.4	1.4	0.5	0.0	799.9	126.3
	1951	72.0	113.9	171.5	126.4	169.5	81.4	29.9	10.3	1.6	0.5	0.0	776.9	123.7
	1952	67.3	106.8	164.2	120.4	161.8	77.3	28.6	10.0	1.8	0.5	0.0	738.5	118.1
	1953	77.0	117.0	187.1	136.1	170.0	77.1	24.8	7.3	0.8	0.6	0.3	798.0	110.8

These data show that a daily average of 800 single axle loads over 10,000 pounds and a daily average of 225 tandem axle loads over 16,000 pounds (total for both axles) passed over the project during 1950. Based on the 1950 totals, there was a decrease in single axle loads of 3.3 and 7.4 percent for 1951 and 1952, respectively, while there was an increase in tandem axle loads of 23.2 and 30.8 percent for the 2 years. The number of tandem axles continued to increase in 1953, being 51.3 percent greater than in 1950, but the number of single axle loads was approximately the same, 798, as in 1950.

There is a marked tendency for the axle loads to cluster just below the state legal load limits of 18,000 lb. for single axles and 32,000 lb. (total for both axles) for tandem axles. During 1950, there was a daily average of 173 single axle loads between 17,000 and 18,000 lb. or 22 percent of the total number of single axle loads over 10,000 lb. During 1950, there was a daily average of 52 tandem axle loads between 30,000 and

TABLE 24

AVERAGE NUMBER OF TANDEM AXLE LOADS OF 16,000 LB. AND OVER (TOTAL FOR BOTH AXLES) PER DAY FOR EACH MONTH FOR 1950-1953. TABULATED IN VARIOUS WEIGHT GROUPS.

Month	Year	Average number of tandem axle loads per day by weight groups (total for both axles)													
		16,000-18,000	18,100-19,900	20,000-21,900	22,000-23,900	24,000-25,900	26,000-27,900	28,000-29,900	30,000-31,900	32,000-32,400	32,500-34,900	35,000-39,900	16,000-39,900	32,100-39,900	
		lb.	lb.	lb.	lb.	lb.	lb.	lb.	lb.	lb.	lb.	lb.	lb.	lb.	
January	1950	6.9	7.0	12.0	15.7	20.8	27.1	32.1	40.7	6.0	11.8	3.2	183.5	21.1	
	1951	10.6	9.9	17.4	22.5	30.2	39.1	44.7	59.2	8.5	18.2	3.1	263.3	29.8	
	1952	10.0	9.8	17.2	22.4	29.7	38.5	45.5	58.2	8.5	17.1	3.1	260.2	28.8	
	1953	10.6	12.1	20.7	26.3	33.4	45.4	54.7	67.8	7.8	10.2	1.2	290.1	19.1	
February	1950	7.6	7.6	13.3	17.4	23.0	29.8	35.4	44.9	6.7	13.0	3.4	201.9	23.1	
	1951	10.5	9.9	17.3	22.4	30.0	38.9	44.6	58.8	8.5	18.0	3.1	261.9	29.6	
	1952	11.2	11.1	19.3	25.2	33.4	43.4	51.1	65.4	9.6	19.3	3.5	292.7	32.4	
	1953	12.6	14.2	24.3	30.9	39.2	53.4	64.1	79.4	9.1	12.0	1.4	340.6	22.5	
March	1950	7.7	7.9	12.0	12.5	18.0	26.7	36.3	37.7	3.6	5.8	0.7	168.9	10.1	
	1951	11.2	11.5	17.5	18.2	26.3	39.2	53.1	55.2	5.3	8.5	1.0	247.0	14.8	
	1952	11.3	11.6	17.7	18.3	26.6	39.6	53.5	55.5	5.4	8.6	1.0	249.0	15.0	
	1953	11.7	13.2	22.4	28.7	36.4	49.9	59.6	72.6	8.3	10.8	1.2	314.8	20.3	
April	1950	8.6	8.7	13.4	13.8	20.1	29.7	40.3	41.9	4.1	6.5	0.8	187.8	11.3	
	1951	11.4	11.6	17.7	18.4	26.7	39.7	53.9	56.0	5.4	8.6	1.0	250.5	15.0	
	1952	11.9	12.2	18.8	19.3	28.1	41.8	56.5	58.6	5.7	9.1	1.1	263.1	16.8	
	1953	12.7	14.3	24.2	31.1	39.5	54.0	64.5	78.6	9.0	11.7	1.3	340.8	22.0	
May	1950	10.2	10.4	15.8	16.4	23.7	35.0	47.6	49.5	4.8	7.6	0.9	222.1	13.4	
	1951	12.9	13.1	20.1	20.8	30.2	44.9	60.8	63.3	6.1	9.7	1.2	283.0	17.0	
	1952	13.5	13.8	21.2	21.7	31.7	46.9	63.5	66.0	6.4	10.3	1.2	296.3	17.9	
	1953	13.8	15.6	26.5	34.0	43.1	59.2	70.5	85.8	9.8	12.9	1.5	372.8	24.2	
June	1950	9.1	11.7	14.1	18.5	20.1	41.7	51.8	51.3	4.5	5.2	0.7	228.6	10.4	
	1951	9.7	12.5	15.0	19.7	21.5	45.7	55.7	56.4	4.8	5.6	0.7	247.2	11.1	
	1952	10.6	13.6	16.5	21.7	23.5	49.0	60.9	60.8	5.3	6.1	0.8	268.8	12.1	
	1953	10.8	12.2	20.7	26.6	33.7	46.1	55.2	67.4	7.7	10.0	1.2	291.6	18.9	
July	1950	10.0	13.0	15.6	20.5	22.3	46.1	57.4	56.7	4.9	5.8	0.7	253.0	11.5	
	1951	10.7	13.7	16.5	21.7	23.7	50.2	61.3	62.0	5.3	6.1	0.8	272.0	12.2	
	1952	11.9	15.3	18.5	24.4	26.4	55.0	68.3	68.2	5.9	6.9	0.9	301.7	13.6	
	1953	12.3	13.9	23.7	30.4	38.5	52.7	63.0	76.8	8.7	11.4	1.3	332.8	21.5	
August	1950	11.4	14.7	17.5	23.2	25.2	52.4	64.7	64.1	5.5	6.5	0.8	286.1	12.9	
	1951	11.7	15.1	18.1	23.8	25.9	55.1	67.3	68.0	5.7	6.7	0.9	298.2	13.4	
	1952	12.8	16.6	19.9	26.3	28.4	59.4	73.6	73.3	6.4	6.4	0.9	325.1	14.7	
	1953	13.0	14.7	25.0	32.0	40.5	55.5	66.2	81.0	9.3	12.1	1.4	350.8	22.7	
September	1950	10.0	13.7	12.8	22.8	30.3	47.7	55.9	70.5	9.7	12.2	1.6	287.1	23.5	
	1951	12.7	17.0	16.2	27.8	38.0	60.0	70.4	89.7	12.9	15.1	2.2	361.9	30.1	
	1952	12.9	17.5	16.5	29.0	38.9	62.0	72.1	92.1	12.7	15.4	2.1	371.1	30.3	
	1953	15.8	17.8	30.3	39.1	49.1	67.5	80.1	97.2	11.1	14.4	1.6	423.9	27.1	
October	1950	8.5	11.7	10.8	19.4	25.7	40.6	47.5	60.0	8.3	10.4	1.4	244.3	20.0	
	1951	10.7	14.4	13.7	23.5	32.2	50.6	59.5	75.7	10.9	12.7	1.8	305.8	25.4	
	1952	11.3	15.4	14.4	25.9	34.0	54.2	63.1	80.5	11.2	13.5	1.9	325.4	26.6	
	1953	13.8	15.6	26.6	34.4	43.2	59.2	70.4	85.4	9.7	12.6	1.4	372.3	23.8	
November	1950	7.6	10.5	9.7	17.3	22.9	36.3	42.4	53.6	7.3	9.3	1.2	218.1	17.8	
	1951	9.5	12.8	12.0	20.7	28.4	44.8	52.6	67.0	9.6	11.2	1.6	270.2	22.5	
	1952	9.7	13.3	12.6	22.0	29.6	46.9	54.8	69.8	9.7	11.8	1.6	282.0	23.1	
	1953	11.6	13.1	22.4	28.9	36.3	49.8	59.3	71.9	8.2	10.6	1.2	313.3	20.1	
December	1950	8.3	8.3	14.4	18.8	24.9	32.4	38.2	48.7	7.2	14.2	3.6	219.1	25.1	
	1951	10.7	10.0	17.5	22.7	30.5	40.1	45.2	59.7	8.6	18.3	3.2	266.5	30.1	
	1952	11.1	10.9	19.1	24.8	33.0	42.8	50.4	64.6	9.5	19.0	3.5	288.8	32.0	
	1953	12.2	13.9	23.8	30.2	38.3	52.2	62.8	77.6	8.9	11.7	1.3	333.0	21.9	
Daily Ave.	1950	8.8	10.4	13.5	18.0	23.1	37.2	45.9	51.7	6.1	9.0	1.6	225.2	16.6	
	1951	11.0	12.6	16.6	21.9	28.6	45.7	55.8	64.3	7.6	11.5	1.7	277.3	20.8	
	1952	11.5	13.4	17.7	23.4	30.3	48.3	59.5	67.7	8.0	12.0	1.8	293.7	21.8	
	1953	12.6	14.2	24.2	31.0	39.3	53.7	64.2	78.5	9.0	11.7	1.3	339.7	22.0	

32,000 lb., or 23 percent of the total number of tandem axle loads over 16,000 lb. For these same weight groups and axle types, there was an increase in the number of tandem axles and a slight decrease in the number of single axles during ensuing years.

In 1950, there was a daily average of 126.3 single axle loads over the legal load limit of 18,000 lb., or 15.8 percent of the total number over 10,000 lb. The percentage of illegal single loads increased to 15.9 in 1951 and 16.0 in 1952, but decreased to 13.8 in 1953. During 1950 there was a daily average of 16.6 tandem axle loads over the legal limit of 32,000 lb., which is 7.4 percent of the tandem axle loads over 16,000 lb. There was practically no change in these percentages in 1951 and 1952, being 7.5 and 7.4 respectively, over the 2 years, but the percentage of overweight tandem axle loads decreased to 6.5 in 1953.

There is a seasonal variation in traffic volume for both single and tandem axles. The

smallest traffic volume for both types of axles occurs in the winter and spring months, while the highest volume is in September for single axles and in August, September, and October for tandem axles.

Special speed and placement studies were made in September 1950 at two locations. The north location, at Station 509+80 was approximately 0.4 mile from the end of the project. In the direction of traffic, the grade at this station is +0.2 percent. Before entering the section having the +0.2 percent grade, there is a long section of -0.2 percent grade.

The south location, at Station 359+00 was approximately 1.3 miles from the southern end of the project. In the direction of traffic, the grade at this station is -0.2 percent. Before entering the -0.2 percent grade, there is a long section of +0.656 percent grade.

The dates of the studies made at each location were as follows: North Station—Monday, Sept. 11, 4 P. M. to 12 P. M.; Wednesday, Sept. 13, 12 P. M. to 8 A. M.; Thursday, Sept. 14, 8 A. M. to 4 P. M. South Station—Monday, Sept. 18, 4 P. M. to 12 P. M.; Wednesday, Sept. 20, 12 P. M. to 8 A. M.; Thursday, Sept. 21, 8 A. M. to 4 P. M.

The average speed and average placement of the right wheels from the west (outside) edge of the pavement for the heavier truck classifications, divided into various axle load groups, are shown in Table 25.

The data in this table are for 954 loaded vehicles having axle loads ranging from 10,000 lb. to 22,000 lb. for single axle loads over 10,000 lb. and for tandem axle loads over 26,000 lb. The placement of these vehicles was entirely within the west or outside lane. This group is the equivalent of 96.3 percent of the total number of loaded trucks having axle loads within the indicated weight ranges, recorded during the speed and placement studies. The remaining 3.7 percent represents trucks either partially or entirely in the left (inside) lane.

There were insufficient vehicles in some weight groups to establish any trends in speeds with respect to comparative speeds of either the different types of trucks or various axle-weight groups of each vehicle type. The average speed for all trucks included in the tabulation was 41.4 mph.

TABLE 25
AVERAGE SPEED AND PLACEMENT OF LOADED TRUCKS AND COMBINATIONS
HAVING AXLE LOADS OF 10,000 LB. AND OVER, TRAVELING IN THE RIGHT (OUTSIDE) LANE, SEPTEMBER^a 1950.
TABULATED BY VARIOUS AXLE-LOADED GROUPS.

Vehicle type	No. of trucks	Maximum axle load on truck or combination ^b	Average gross weight of truck or combination	Average speed ^c	Distance from outside edge of pavement to right wheel ^d	
					Average	Minimum and maximum
		lb.	lb.	mph.	feet	feet
Single-axle vehicles						
Single unit, 6-tired	34	10,000-16,000	17,250	41.8	4.0	2.5-5.0
	24	16,000-18,000	22,058	41.0	4.1	2.0-6.5
	5	18,000-22,000	23,680	39.2 ^c	4.2	3.0-5.5
	1	Over 22,000	28,300	50.2	4.0	4.0
Tractor-truck semitrailer, 3-axle	202	10,000-16,000	29,604	41.5	3.9	1.5-6.5
	211	16,000-18,000	37,891	41.5	3.8	1.5-6.0
	135	18,000-22,000	40,462	41.4	4.0	2.0-6.0
Tractor-truck semitrailer, with full trailer, 5 axle	1	10,000-16,000	55,000	38.5	4.5	4.5
	15	16,000-18,000	68,873	37.6	3.4	2.0-4.5
	1	18,000-22,000	72,300	38.5	4.5	4.5
Tandem-axle vehicles						
Single unit-tandem axle	9	26,000-32,000	34,411	36.4	4.0	3.0-5.5
	3	32,000-35,000	39,167	44.9	3.7	3.5-4.0
Tractor-truck semitrailer 4-axle	257	26,000-32,000	43,982	41.5	4.0	1.5-6.0
	25	32,000-35,000	55,076	43.9	3.9	2.0-5.5
	2	Over 35,000	54,950	38.6	3.3	3.0-3.5
Tractor-truck semitrailer, 5-axle	21	26,000-32,000	62,386	39.3	4.4	2.0-5.0
	8	32,000-35,000	69,550	36.9	3.9	3.0-4.5
Total	954					

^a Speed and placement studies extended over a total period of 48 hours. Data were obtained during one 8-hour period on each of 6 calendar days.

^b Maximum axle load on truck or combination irrespective of location of axle from front to back of vehicle. For tandem axles, the axle-load group is for total load on both axles.

^c The speed was determined for only 3 of the 5 single-axle, 6-tired trucks in the 18,000-22,000 pound group. For all other vehicle types and axle-load groups, the speed was determined for at least 92 percent of each number of trucks counted.

^d Distances shown are from edge of pavement to the midpoint between the contact areas of the dual tire assembly.

TABLE 26
PAVEMENT ROUGHNESS INDEX, IN INCHES PER MILE, OF PLAIN CONCRETE PAVEMENT (15-FT. JOINT SPACING)

Thickness and type of subbase	Roughness index of mile one, in inches per mile								Roughness index of mile three, in inches per mile								Ave. increase for miles 1 and 3 ^a	
	West (outer) lane				East (inner) lane				West (outer) lane				East (inner) lane					
	Nov. 1949	Mar. 1952	Dec. 1953	Increase ^a	Nov. 1949	Mar. 1952	Dec. 1953	Increase ^a	Nov. 1949	Mar. 1952	Dec. 1953	Increase ^a	Nov. 1949	Mar. 1952	Dec. 1953	Increase ^a	Outer lane	Inner lane
3-inch dense-graded	131	154	187	36	135	154	154	19	153	186	193	40	148	186	180	32	38	26
5-inch dense-graded	126	160	193	67	135	154	180	45	139	193	193	54	135	147	167	32	60	38
8-inch dense-graded	135	167	180	45	144	167	180	36	132	213	206	44	144	167	180	36	44	36
All dense-graded	131	160	180	49	138	158	171	33	151	197	197	46	142	167	176	33	47	33
3-inch open-graded	130	160	167	37	139	167	180	41	144	171	193	49	144	154	167	23	43	32
5-inch open-graded	144	184	180	36	158	180	180	22	126	159	167	41	135	147	154	19	38	20
8-inch open-graded	130	167	187	37	144	167	180	36	149	163	167	18	140	154	167	27	28	32
All open-graded	135	170	171	37	147	171	180	33	140	164	176	36	140	152	163	23	36	26
3-inch soil-cement	144	187	206	62	153	193	193	40	135	180	180	45	135	147	154	19	53	30
5-inch soil-cement	157	199	193	36	153	167	180	27	144	163	206	62	144	154	167	23	49	25
All soil-cement	151	193	199	49	153	180	186	33	140	172	193	53	140	151	161	21	51	27
Untreated	139	180	219	80	153	173	167	14	131	174	231	100	135	149	167	32	90	23
All subbase sections	137	172	182	45	145	169	178	33	144	178	188	44	141	157	167	26	44	30
All sections	137				146				143				140					

^a November 1949 to December 1953.

Three-axle and four-axle tractor-truck semitrailers were the most numerous types recorded. Study of the basic data indicated that there was no appreciable difference between average day and night speeds for either of these vehicle types. However, the average position of the right wheels of the 3-axle tractor-truck semitrailers and the 4-axle tractor-truck semitrailers having the heavier axle loads were 0.5 ft. and 0.4 ft., respectively, farther from the pavement edge during the hours of darkness.

Although there were insufficient vehicles in some of the weight groups for the data to be conclusive, there was a tendency for the tandem-axle vehicles in the heaviest axle groups to travel closer to the edge of the pavement than those for lighter axle groups.

OBSERVATIONS ON FINISHED PAVEMENTS

In order to determine (1) the effectiveness of the various types of subbases for the prevention of pumping, and (2) differences in performance of the pavements on the various types of subbases, observations have been made since the experimental pavement was completed. The observations include pavement roughness, differential levels, visual inspections, and moisture-cell readings.

Pavement Roughness

Roughness indices for each lane of each section were obtained with the Bureau of Public Roads roughness indicator in November 1949, before the project was opened to traffic. Additional sets of readings were obtained in March 1952 and December 1953. The data are summarized in Tables 26 and 27. Figure 26 shows the roughness index of the traffic lane for each section.

For the plain concrete pavement with 15-ft. contraction joint spacing, constructed on subbases in the first and third experimental miles, the average pavement roughness

TABLE 27
PAVEMENT ROUGHNESS INDEX, IN INCHES PER MILE, OF REINFORCED CONCRETE PAVEMENT (40-FT. JOINT SPACING)

Thickness and type of subbase	Roughness index of mile two, in inches per mile								Roughness index of mile four, in inches per mile								Ave. increase for miles 2 and 4 ^a	
	West (outer) lane				East (inner) lane				West (outer) lane				East (inner) lane					
	Nov. 1949	Mar. 1952	Dec. 1953	Increase ^a	Nov. 1949	Mar. 1952	Dec. 1953	Increase ^a	Nov. 1949	Mar. 1952	Dec. 1953	Increase ^a	Nov. 1949	Mar. 1952	Dec. 1953	Increase ^a	Outer lane	Inner lane
3-inch dense-graded	130	141	121	-1	126	141	141	15	126	137	129	3	121	121	129	8	1	12
5-inch dense-graded	117	133	154	37	131	129	141	10	117	124	141	24	126	129	129	3	30	7
8-inch dense-graded	121	133	141	20	126	154	141	15	130	141	141	11	121	129	154	33	16	24
All dense-graded	123	136	141	19	126	141	141	13	124	134	137	13	123	126	137	15	16	14
3-inch open-graded	121	146	154	33	126	134	167	41	131	141	141	10	122	123	141	19	21	30
5-inch open-graded	126	150	141	15	135	141	141	6	117	160	141	24	130	129	141	11	20	8
8-inch open-graded	122	133	141	19	122	136	129	7	121	133	141	20	121	139	141	20	20	14
All open-graded	123	136	145	22	129	139	146	18	123	145	141	18	124	127	141	17	20	17
3-inch soil-cement	117	129	129	12	131	136	141	10	121	137	141	20	130	121	141	11	16	10
5-inch soil-cement	121	129	141	20	126	129	141	15	130	133	154	24	126	134	129	3	22	9
All soil-cement	119	129	135	16	129	133	141	12	126	135	148	22	128	128	135	7	19	10
Untreated	121	124	141	20	130	141	141	11	126	133	141	15	126	129	141	15	18	13
All subbase sections	122	137	141	19	128	138	143	15	124	136	141	17	125	127	138	13	18	14
All sections	122				128				124				125					

^a November 1949 to December 1953.

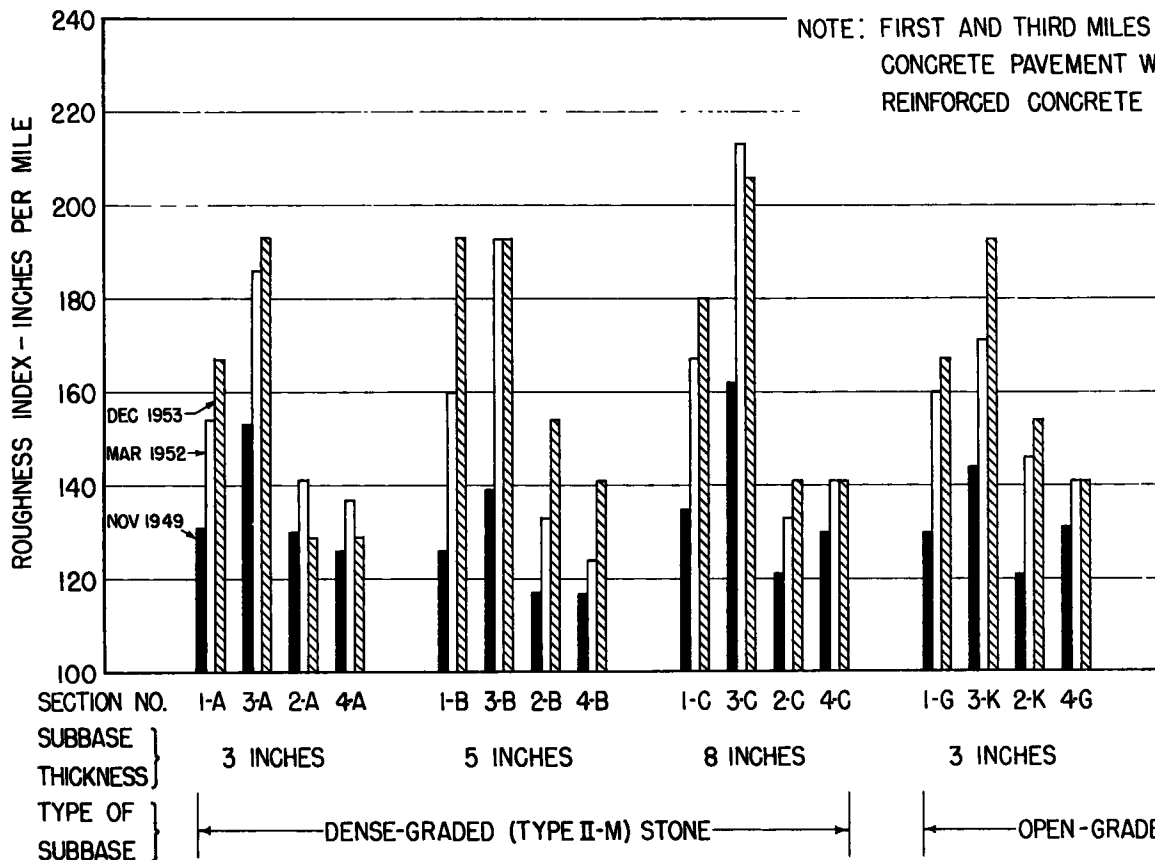

Figure 26. Roughness index of outer (traffic) lane of each

index in November 1949 was 140 in. per mile for the outer (traffic) lane and 143 for the inner (passing) lane, the variations being from 126 to 162 in. per mile. The initial average roughness index of the reinforced concrete pavement with 40-ft. joint spacing, constructed on subbases in the second and fourth miles, was 123 in. per mile in the traffic lane and 126 in the passing lane, with section variations ranging from 117 to 135 in. per mile. The roughness index of the plain concrete pavement placed directly on the subgrade was 135 in. per mile in the traffic lane and 144 in the passing lane, while that of the reinforced concrete pavement placed without subbase was 124 in. per mile in the traffic lane and 126 in the passing lane.

By December 1953 the average roughness index for the plain concrete pavement on subbases had increased 44 in. per mile in the traffic lane and 30 in. per mile in the passing lane. In the traffic lane of this type of pavement built on subbases, the greatest increase in roughness index, 67 in. per mile, occurred in the pavement built on the 5-in. dense-graded subbase in the first mile, while the minimum increase, 18 in. per mile, occurred in the 8-in. open-graded subbase section of the third mile. The average increase in roughness index for plain concrete pavement built without subbase was 90 in. per mile for the traffic lane and 23 in. per mile for the passing lane.

There was less increase in roughness in the reinforced concrete pavement with 40-ft. joint spacing than in the plain concrete pavement. For the former, the average increase for those sections of both miles built on subbases was 18 in. per mile in the traffic lane and 14 in the passing lane. The average increase in roughness index of the

FIRST TWO BAR GROUPS IN EACH SERIES OF FOUR) HAVE PLAIN
 15-FOOT JOINT SPACING SECOND AND FOURTH MILES HAVE
 PAVEMENT WITH 40-FOOT JOINT SPACING.

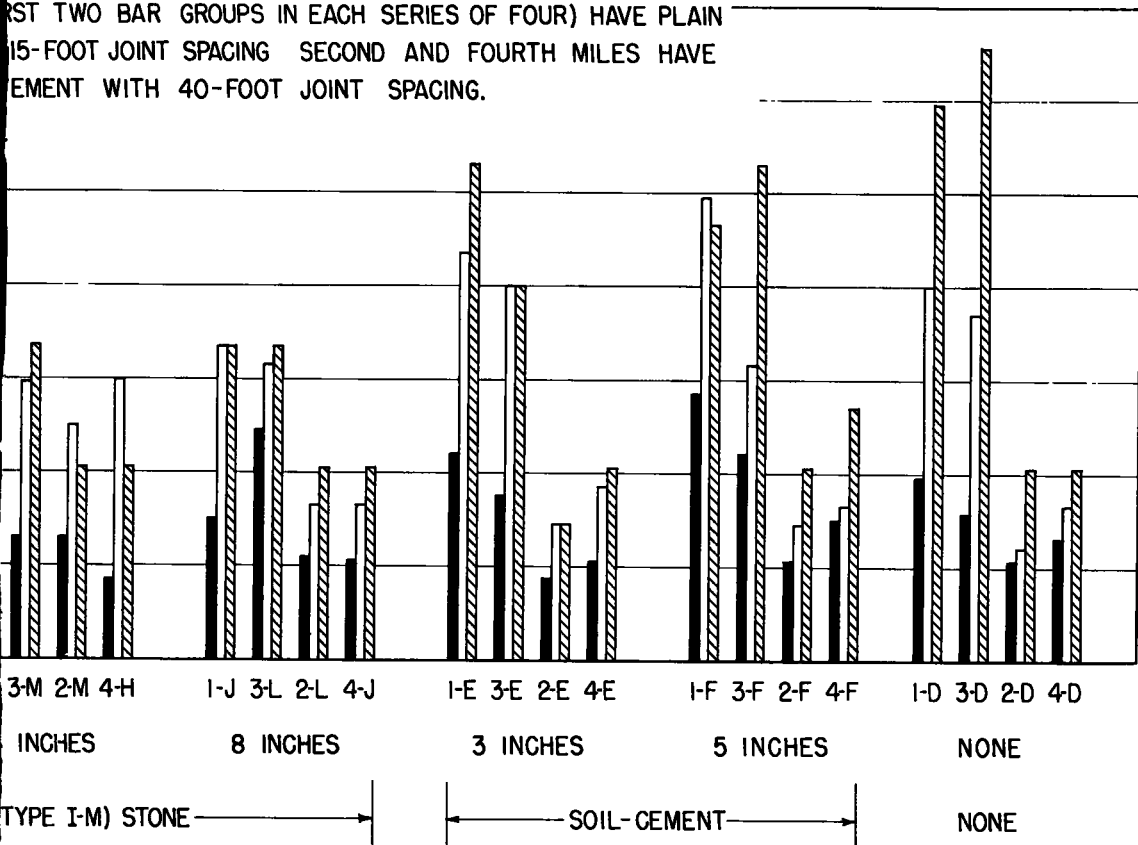

section in November 1949, March 1952 and December 1953.

traffic lane of the reinforced concrete pavement built without a subbase was 18 in. per mile. The maximum increase in roughness index in the traffic lane, 37 in. per mile, occurred in the 5-in. dense-graded subbase section of the second mile, while at least one section on each type of subbase had an increase of not more than 10 in. per mile. However, the pavement on the 5-in. open-graded subbase increased in roughness 43 in. per mile from 1949 to 1952 but decreased 19 in. per mile from 1952 to 1953.

Further observations after subjection to traffic for several years will be necessary before it can be determined (1) whether the thicker subbases result in significantly smoother pavements, and (2) whether one type of subbase is better than the others.

Precise Levels

Level readings were obtained for each section in October 1949, before the project was opened to traffic, at the points shown in Figure 5. Additional readings were taken in May 1950, October 1950, February 1951, August 1951, and February 1952.

The February 1951 level readings are not discussed in this report. The initial readings for that time indicated that the elevation of most of the level points had increased, hence, it was presumed that the extensive period of cold weather immediately preceding the determination of elevations had caused freezing and expansion of the subgrade, and only limited level readings were obtained. The data for February 1952 are discussed because the average temperature for that month was higher than in February 1951 and investigations showed that freezing had extended to a depth of only a few inches in the

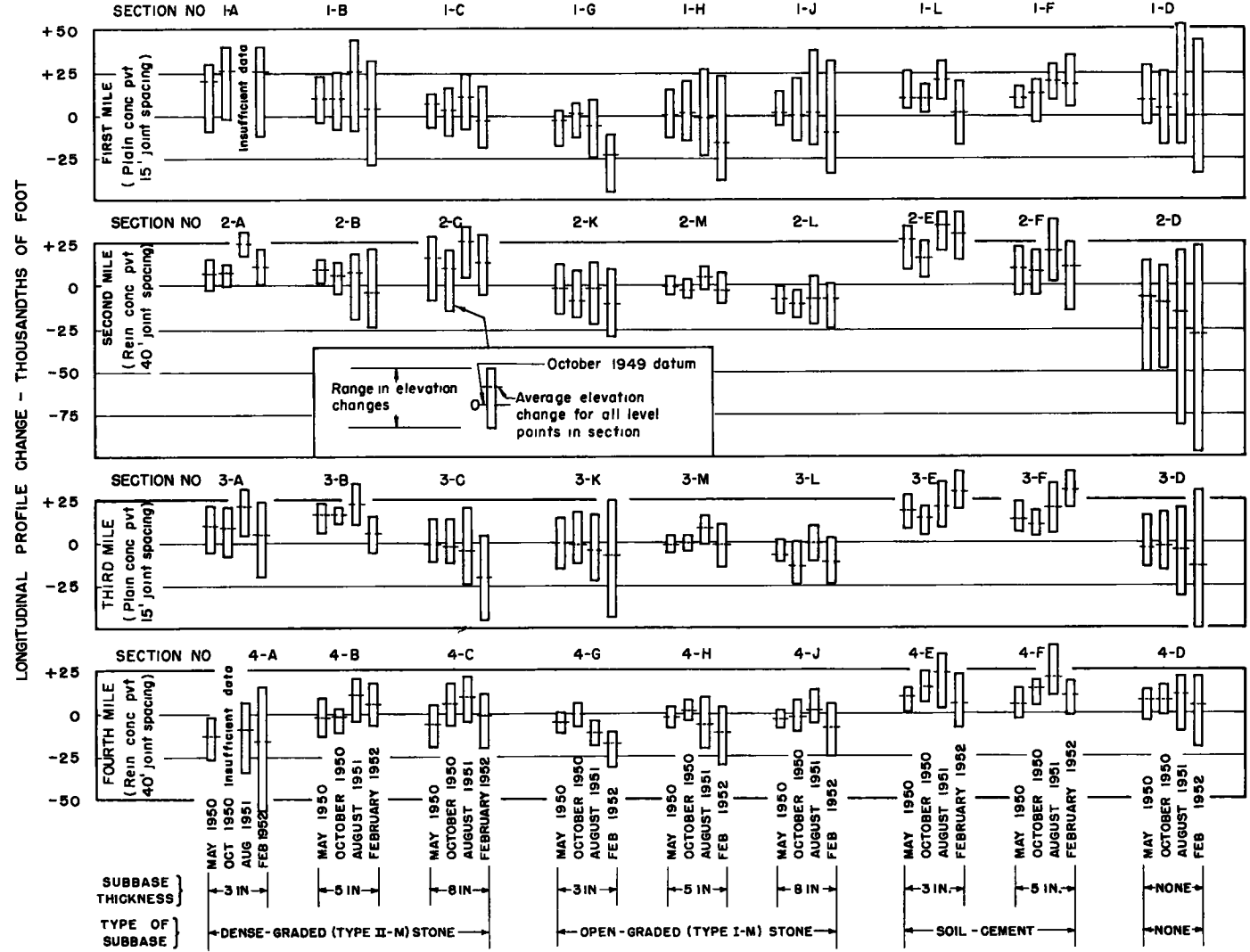

Figure 27. Longitudinal profile changes for each section at centerline of traffic (outer) lane.

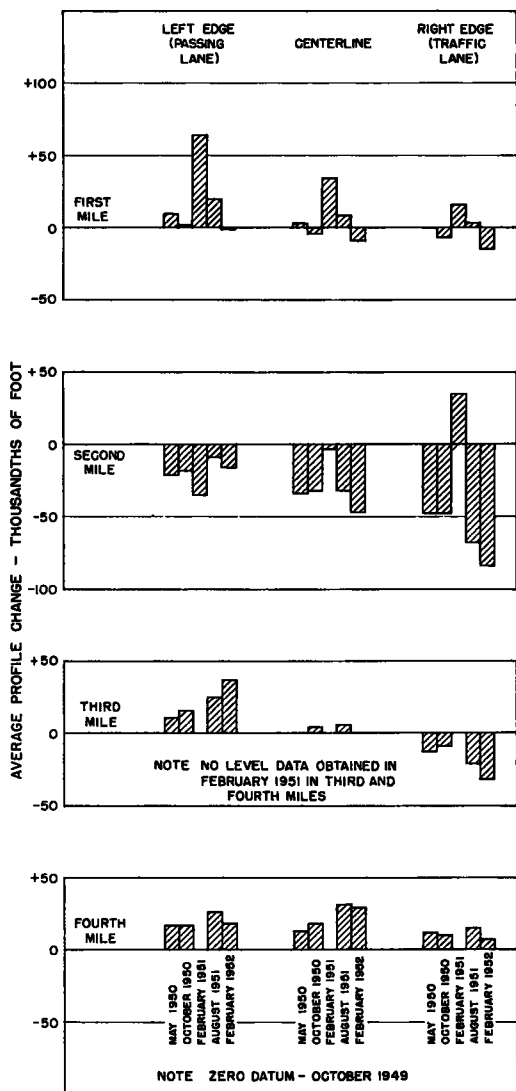

Figure 28. Average profile changes of pavement sections with no subbase.

traffic lane when the level readings were taken in February 1952 was 0.015 ft. for section 1-D (first mile), 0.084 ft. in section 2-D (second mile), and 0.032 ft. in section 3-D (third mile). In section 4-D (fourth mile), the average elevation had increased 0.007 ft. by February 1952, compared to October 1949, but had decreased slightly from August 1951 readings. There has also been some decrease in elevation at the centerline of the pavement for these sections, but the depression has been less than at the right edge of the traffic lane.

Visual Inspection

Condition surveys, which include observations of pumping conditions and tabulation of cracking and faulting have been made several times since the project was opened to traffic.

Spalling occurred at some of the joints soon after the pavement was constructed. Most of the spalling probably was caused by finishing operations.

shoulder material at the time of the later readings.

Except for the sections with no subbase, the average section profile changes at the centerline, quarter-points and inner and outer edges of the 24-ft. pavement were less than 0.05 ft. for each section for all but the February 1951 period. No significant trend in the profile changes that can be attributed to known subgrade or subbase conditions was noted for the sections with subbases.

Figure 27 shows the change in elevation of the level points at the center of the traffic lane for each set of level determinations except those made in February 1951. The elevation of the level points in October 1949 is used as a zero datum for computation of the subsequent changes. The average profile change of each section is based on readings at 18 to 20 level points in sections having plain concrete pavement, 20 to 24 points in the three sections having reinforced concrete pavement placed on open-graded stone subbase with drains, and 10 to 16 points in all other sections having reinforced concrete pavement.

Figure 27 shows that the greatest range in elevation changes at the center of the traffic lane has occurred in the sections without subbases. The greatest movement occurred in sections 2-D, reinforced concrete pavement, in February 1952, the level point changes ranging from 0.024 ft. above to 0.097 ft. below the 1949 datum, and having an average change of 0.028 ft. below the 1949 datum.

For the sections without subbase, Figure 28 shows the average profile changes at the concentrated level-point installations such as shown in Figure 5. Using the October 1949 profile as a datum, the average decrease in elevation at the right edge of the

TABLE 28
DEVELOPMENT OF TRANSVERSE CRACKS IN PANELS OF REINFORCED CONCRETE PAVEMENT WITH VARIOUS TYPES OF SUBBASES^a

Date of crack survey	Percentage of panels having one or more transverse cracks																						
	Dense-graded stone subbase, having thickness of						Open-graded stone subbase, having thickness of						Soil-cement subbase, All types & thickness of subbase						No subbase		All sections, including those with no subbase		
	3 inches		5 inches		8 inches		3 inches		5 inches		8 inches		3 inches		5 inches		thickness of subbase		Inner	Outer	Inner	Outer	
Nov 11, 1949	Opened to traffic (no cracks)																						
Sept. 12, 1950	4	4	4	4	0	4	0	0	0	4	0	0	0	0	0	0	0	1	2	4	4	1	2
Jan. 18, 1951	8	15	8	8	8	20	4	7	0	8	0	0	0	0	0	0	3	7	12	15	4	8	
April 9, 1951	12	19	19	19	12	24	4	11	8	12	0	0	0	4	0	0	7	11	12	15	7	11	
Aug. 23, 1951	12	19	19	19	16	32	15	22	20	28	4	4	0	4	0	0	11	16	12	15	11	16	
Dec. 6, 1951	12	19	19	23	16	32	15	22	24	32	4	4	0	4	0	0	11	17	12	15	11	17	
Mar. 11, 1952	42	46	31	46	28	48	26	33	32	40	15	22	0	7	4	19	22	33	19	35	22	33	
Nov 20, 1952	96	96	100	100	88	100	100	100	88	100	85	96	81	78	73	77	89	93	85	96	89	94	
Dec. 1, 1953	96	96	100	100	92	100	100	100	92	100	89	85	73	85	92	96	92	96	85	96	91	96	
Total no of panels	26	26	26	26	25	25	27	27	25	27	27	27	27	27	26	26	209	209	26	26	235	235	

^a Planned length of panels is 40 feet. Panels less than 35 feet in length or overlapping two types of thicknesses of subbase are not considered.

Pavement joints have been maintained in the same manner as for other similar Indiana pavements. The asphalt joint filler has been removed and replaced when necessary.

Crack Surveys. At the time of the last condition survey, in December 1953, there were 4 transverse cracks in the plain concrete pavement, which has a contraction joint interval of 15 ft. All of these cracks are in the pavement sections which have no subbase.

In December 1953, 96 percent of all reinforced concrete panels (having a planned length of 40 ft.) had a transverse crack in the outer (traffic) lane, and 91 percent had a transverse crack in the inner (passing) lane. These transverse cracks occur within the middle half of the panels. In the traffic lane, the percentage of cracked panels was the same for the pavement without subbase as for the pavement with subbase. However, in the passing lane, only 85 percent of the panels without subbase had cracked, while 92 percent of the panels on subbases had cracked.

Table 28 shows that, by December 1953, for the outer (traffic) lane of the reinforced concrete pavement: (1) a transverse crack had occurred in all panels of sections having 5 and 8 in. of dense-graded stone subbase and 3, 5 and 8 in. of open-graded stone subbase; and (2) the minimum percentage of transverse cracking for all types of subbase, 85 percent of the panels, occurred in sections having soil-cement subbase.

The most rapid increase in transverse cracking of the panels of reinforced concrete pavement occurred in the period from March 11, 1952 to November 20, 1952, in which the percentage of cracked panels for all sections increased from 33 to 94 in the outer lane and from 22 to 88 in the inner lane.

These transverse cracks in the reinforced concrete pavement are closed cracks.

Pavement Pumping. Due to the variety of subbase materials and thickness of subbases, as well as differences in pavement design, the evidence of pumping is not the same in all sections. Pumping may be described by types as follows:

Type I. The soil-water slurry varies in consistency from a thin liquid to a thick mud and is ejected either along the edges of the pavement or along joints or cracks in the interior of the slab. This type of pumping usually results in pavement cracking or faulting. Sediment or mud boils on the pavement, such as that in Figure 29 and 30, are evidences of this type of pumping.

Type II. Clear or slightly discolored water mixed with granular material or fragments of soil-cement is ejected along the edges of the pavement, as shown in Figures 31 and 32. This is referred to as a "blow-hole" because of the cavity which is formed when the soil-water mixture is forced from the subbase. Some discoloration or staining of the pavement edges may occur. Faulting and cracking have not been observed in connection with this type of pumping.

Type III. Slightly discolored or clear water is pumped from cracks or joints in the interior of the slab. This type of pumping is associated with consolidation of granular materials. Therefore, it may often be followed by faulting at joints and cracking between joints, but usually does not result in structural failure. This type has not been observed on the experimental project.

In the traffic lane of sections with no subbase and having plain concrete pavement with a 15-ft. contraction joint interval, there has been either active pumping or evidence of pumping of Type I at every joint and along the outside edge of the slabs. Typical pumping conditions on these sections of pavement are shown in Figures 29 and 30. Faulting occurred at some joints in 1953. Pumping in these sections had become so

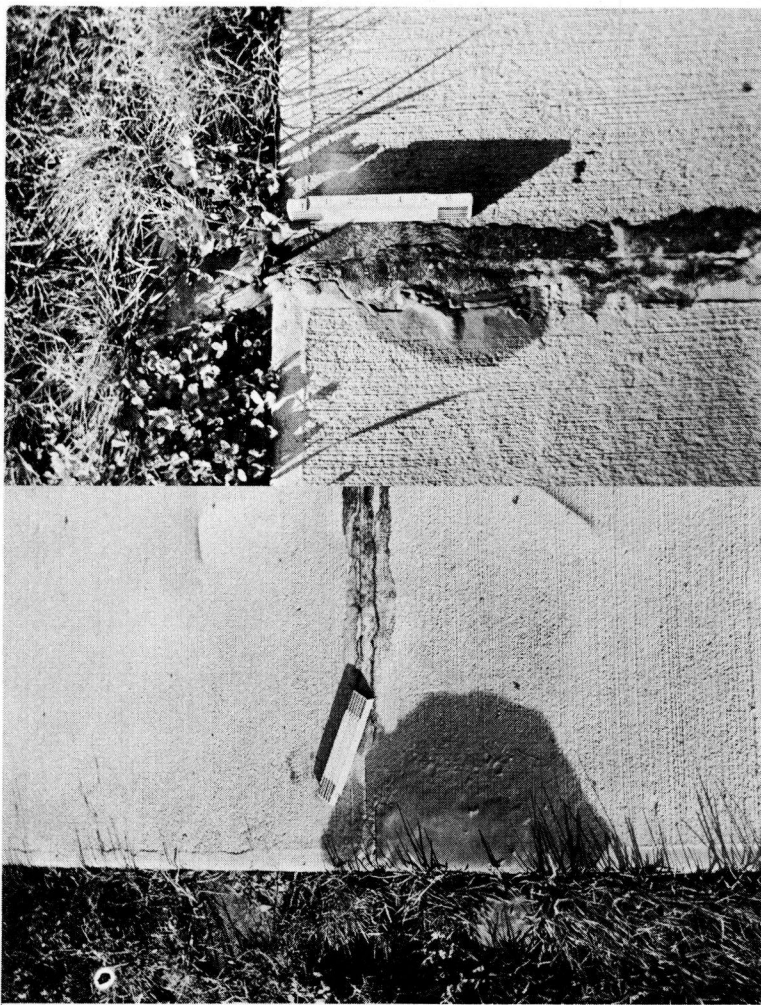

Figure 29. Sediment has been pumped onto pavement at contraction joints in sections having plain concrete, 15-foot joint spacing and no subbase (type I pumping). At top is Station 454+52; at bottom, Station 454+07.

severe in 1953 that it was decided that considerable faulting might occur during the spring break-up period of 1954 unless corrective action was taken. Consequently, the pavement sections having no subbases in the first and third experimental miles were subsealed with asphalt in July 1953. The 30-45 penetration asphalt was pumped through holes drilled about 3 feet from the transverse joints, at the center of the traffic and passing lanes. An average of 19.4 gal. of asphalt was used per hole, and the traffic lane required about twice as much as the passing lane. However, subsealing was not very effective at some joints. Sufficient pumping and faulting occurred at four joints in the traffic lane to cause transverse cracks in the panels during the winter of 1953-54.

Progressive pumping and faulting continued at these joints during the spring of 1954, as shown in Figure 33.

Some pumping has occurred along the outside edge of the untreated sections having reinforced pavement with a contraction joint interval of 40 feet. However, there has been no pumping at the joints or cracks in these sections.

Granular material has been extruded along the outer edge of the pavement in all sections having dense-graded stone (Type II-M) subbase, as shown in Figure 31. The extrusion (Type II pumping) was infrequent and of minor intensity except in the cut sections

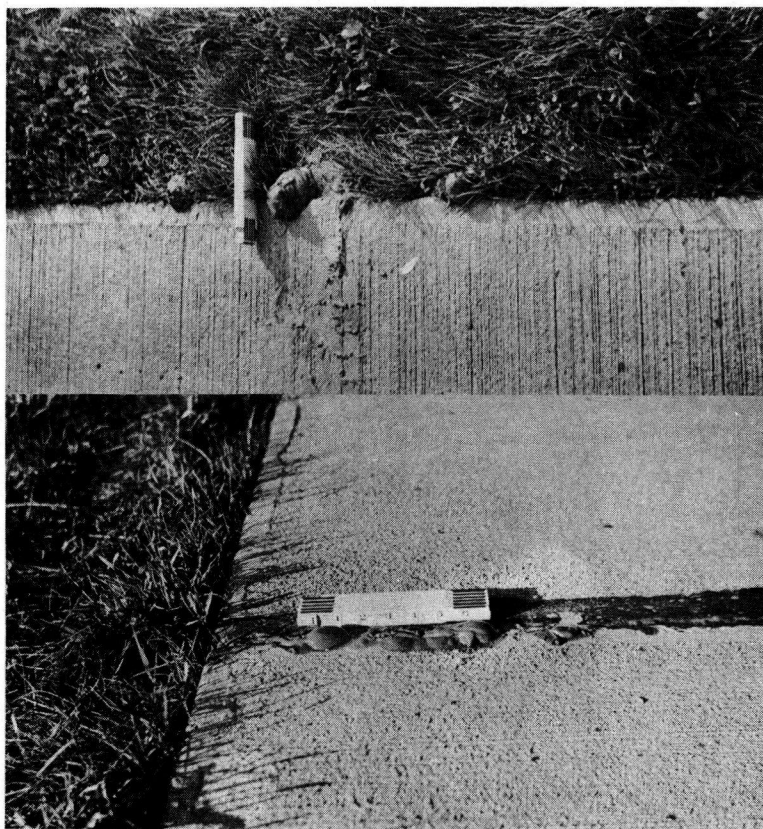

Figure 30. Mud boils have been pumped onto pavement at the outer edge of the slabs and at the joints in sections having plain concrete, 15-foot joint spacing and no subbase (type I pumping). At top is Station 317+79; bottom, Station 454+37.

in the second and fourth miles. There was no extrusion of granular material along the joints in these sections.

Soil-cement material has been extruded at some of the joints in the plain concrete pavement and at the outer edge of the pavement in all sections having soil-cement subbases, as shown in Figure 32. In general, the intensity and frequency of occurrence were considerably higher than for the dense-graded stone subbase.

There has been no extrusion of granular material in the sections having an open-graded stone subbase.

No pumping has been observed in the passing lane of any of the experimental sections.

Moisture Cells

The electrical resistance of each of the moisture cells has been determined at frequent intervals, usually each month during the first two years. Later, the readings were obtained seasonally.

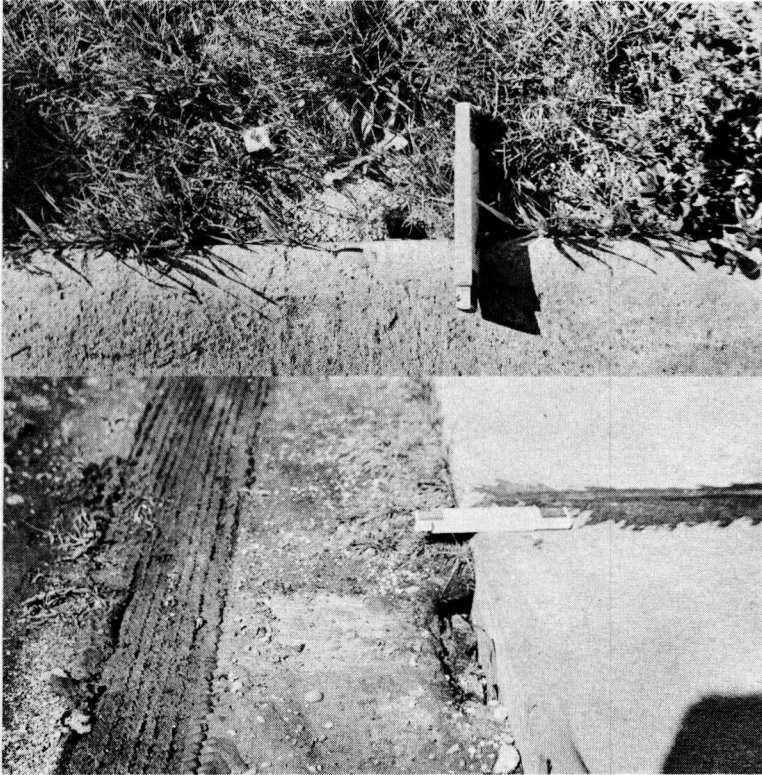

Figure 31. Extrusion of granular material at edge of pavement from dense-graded stone subbases (type II pumping). Reinforced concrete pavement with joint spacing of 40 feet. At top is Station 514+21, 8-inch subbase; bottom is Station 523+00, 5-inch subbase.

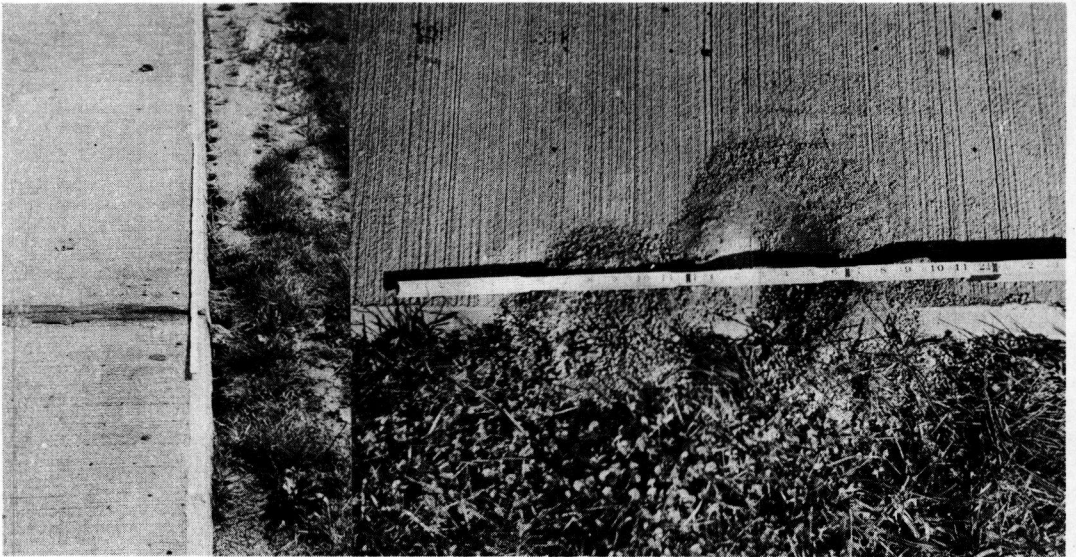

Figure 32. Extrusion of material at edge of pavement slab in 3-inch soil-cement subbase section (type II pumping). Pavement is reinforced concrete with joint spacing of 40 feet. Right is Station 360+67; on the left is Station 358+67.

Initially, an exhaustive attempt was made by the state to calibrate the moisture cells by the method described by Bouyoucos (7). However, moisture contents determined by actual sampling did not agree with the calibration curves. It was believed that part of the disagreement was due to the fact that the density of the soil was not considered in preparation of the calibration curves.

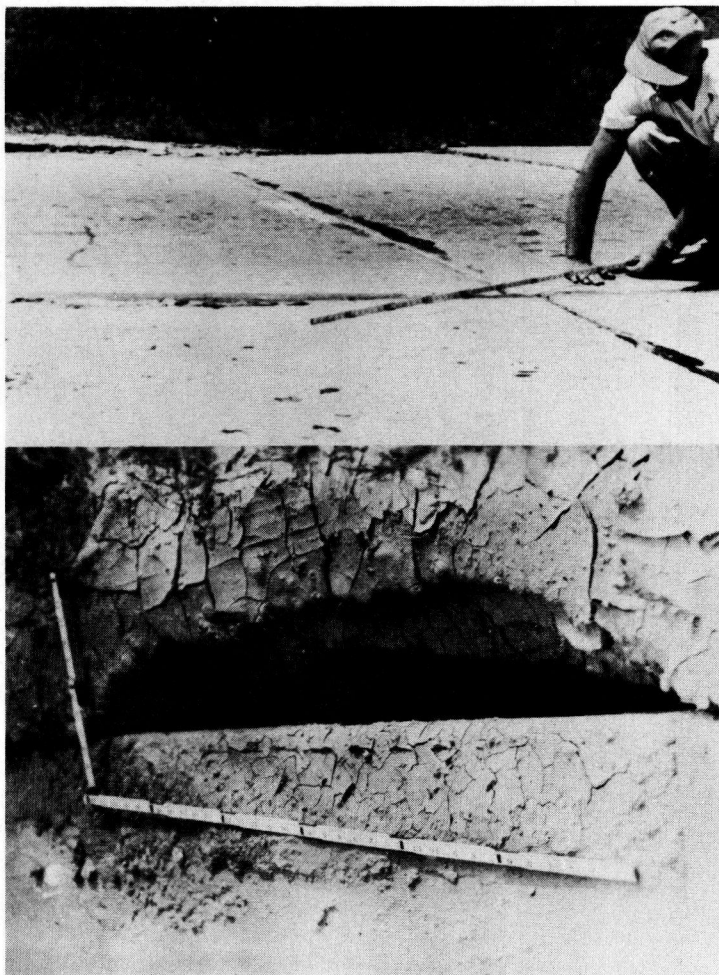

Figure 33. Faulting and pumping of plain concrete pavement in spring of 1954. (15-foot joint spacing, no subbase). Top: Pavement slabs have been depressed at joint and have transverse crack about 8 feet from joint. Bottom: Slurry and blow-hole at outer edge of pavement (upper-left portion of top).

Preliminary investigations by the Bureau of Public Roads indicated that the moisture content corresponding to the electrical resistance reading of the Bouyoucos moisture cell in the field could be determined from calibration curves prepared in the laboratory. These investigations also showed that the electrical resistance of the cell, for a constant moisture content, varied inversely with the dry density of the soil. Consequently, it was necessary to prepare calibration curves for each soil, covering the range of both moisture content and density anticipated in the soil in which the cells were inserted in the field. For the experimental project, calibration curves were prepared for increments of five pcf. dry density of the soil and the cells were normally calibrated at moisture content increments of one percent for each of the curves.

The method of calibration will be described in a later report. Figure 34 shows the calibration curves for an A-6(10) soil obtained from the project. The resistance readings are corrected to 70 F.

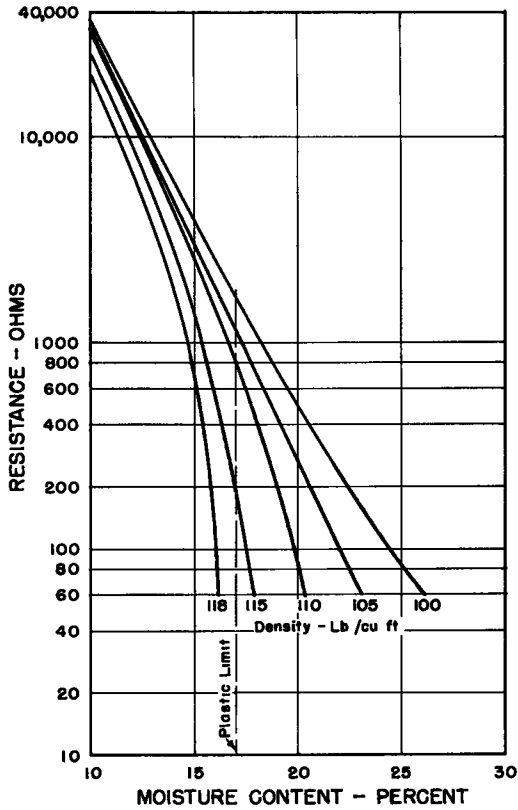

Figure 34. Moisture-cell calibration curves for A-6(10) soil.

Figure 35 shows the cell resistance readings of the installation in the subgrade of the soil-cement subbase section, 1.0 ft. left of the outer (right) edge of the pavement, for the period from November 1949 through November 1952. The figure also shows the actual moisture contents for the period of April 1950 through September 1951. The moisture contents were determined from soil samples obtained at the elevation of the cells but beneath the outer edge of the pavement. The soil at $\frac{1}{2}$ - and 6-in. depths in the subgrade at this installation in an A-6(10) material which has the same physical characteristics as that used in preparing the calibration curves of Figure 34, but is an A-6(11) soil at a depth of 12 inches.

Since the electrical resistance, for a constant soil moisture content, varies inversely with the dry density of the soil, and no density tests have been made in conjunction with the cell readings, the selection of the proper calibration curve to be used in determining the moisture content at the cell is difficult. However, if it is assumed that the subgrade soil is 90 percent saturated, which Hicks (8) and Kersten (9) have reported is normal for a clay subgrade several months after a pavement is constructed in a semi-humid region, the density of the soil can be deter-

TABLE 29
MOISTURE-CELL READINGS AND ACTUAL MOISTURE CONTENTS OF SUBGRADE AT STATION 324+09.4,
11.0 FEET RIGHT OF CENTERLINE, 3-INCH SOIL-CEMENT SUBBASE SECTION

Date	Cell at $\frac{1}{2}$ -inch depth ^a				Cell at 6-inch depth ^a			
	Field sample		Resistance	Moisture content from calibration curve	Field sample		Resistance	Moisture content from calibration curve
Actual moisture content	Dry density ^b	Actual moisture content			Dry density ^b			
	percent	pcf.	ohms	percent	percent	pcf.	ohms	percent
April 1950	26.7	93.5	240	24.5 ^c	25.8	95.0	370	22.5 ^c
June 1950	21.6	102.2	175	22.0	13.2	120.7	240	14.5 ^c
July 1950	18.4	108.6	200	19.6	16.7	112.1	240	18.0
Aug. 1950	21.2	103.0	195	21.4	14.0	118.5	220	15.6 ^c
Sept. 1950	16.7	112.2	200	18.1	16.2	113.6	195	17.7
Oct. 1950	20.6	104.0	175	21.2	17.1	111.3	180	18.6
Nov. 1950	18.5	108.2	215	19.5	17.2	111.2	160	18.7
Dec. 1950	17.7	109.8	220	18.9	14.9	116.4	220	16.3
Mar. 1951	20.9	103.7	140	22.0	17.2	111.2	165	18.7
April 1951	18.5	108.2	145	20.1	15.4	115.3	160	17.0
May 1951	19.2	107.0	110	21.0	14.9	116.3	180	16.4
June 1951	14.9	116.3	100	16.9	15.1	115.9	190	16.6
July 1951	17.3	111.1	100	19.2	17.2	111.2	200	18.6
Aug. 1951	15.0	116.1	95	17.0	17.8	109.7	165	19.4
Sept. 1951	16.7	112.2	95	18.9	16.4	113.2	150	18.1
Average	18.9			20.0	16.6			17.8

^a Cell placed in A-6(10) soil.

^b Based on specific gravity of 2.70 and assumption that soil is 90 percent saturated.

^c Approximate. No calibration curve available for density less than 100 or more than 118 pounds per cubic foot.

mined when it has the moisture content measured by the actual soil sampling.

Table 29 gives the actual moisture contents shown in Figure 35, the dry density of the soil when it is 90 percent saturated, and the moisture content determined from the calibration curves by using the cell resistance and the dry density corresponding to 90 percent saturation. The average moisture content, determined from samples obtained

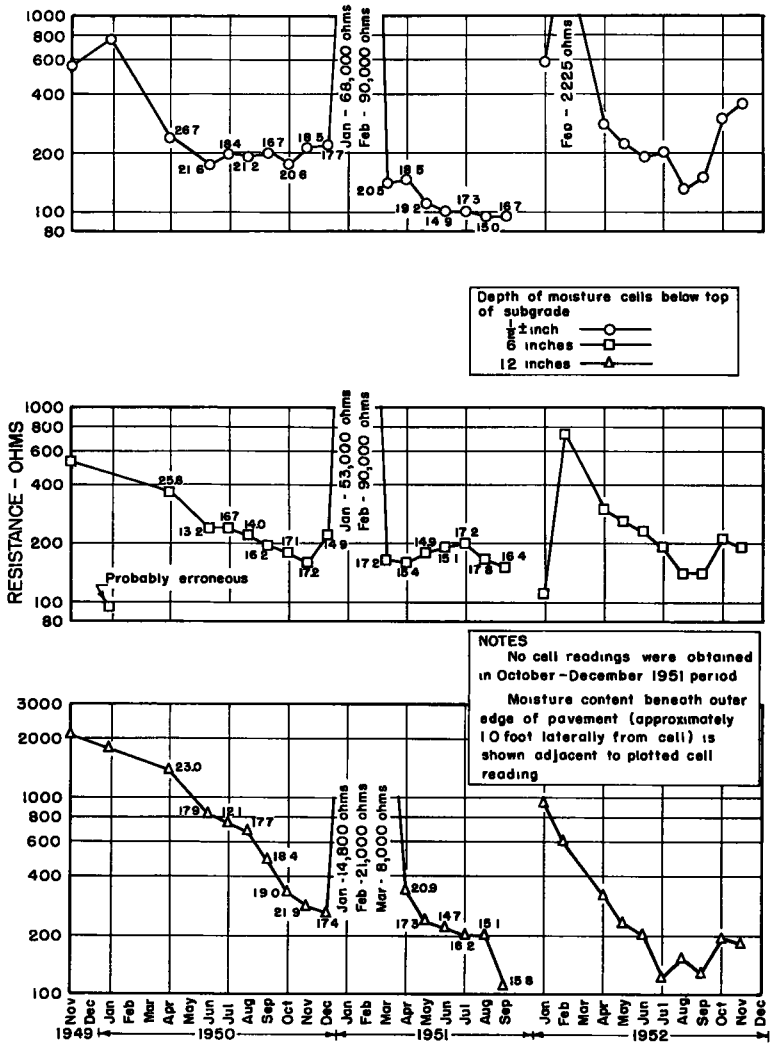

Figure 35. Moisture-cell readings, November 1949 to November 1952, for cell installation in subgrade 1.0 foot left of outer (right) edge of pavement, Station 324+09.4. 3-inch soil-cement subbase section.

below the edge of the pavement, was 18.9 percent at 1/2-in. depth in the subgrade and 16.6 percent at 6-in. depth. The moisture contents determined from the resistance readings and calibration curves were 20.0 and 17.8 percent, respectively, for the two depths, or approximately 1.1 percentage points higher than the actual moisture content. The maximum difference between the actual and cell moisture contents was 3.3 percent. For the 30 cell readings used in the averages in Table 29, 27 of the cell moisture contents were within 2.0 percentage points of the actual moisture content.

Although these data show reasonably good agreement between the actual and cell moisture contents, several sources of error may tend to nullify each other to produce

the favorable results. These factors are as follows: (1) difference in moisture content of the soil adjacent to the cell and the soil below the edge of the pavement; (2) imperfections in the procedure for calibrating the moisture cells; (3) improper density used when determining the moisture content corresponding to the cell-resistance readings; (4) failure to determine the temperature of the soil adjacent to the cell at the time the resistance was determined; and (5) equipment variations.

With regard to the first source of error, the actual moisture content used for comparison was determined from a sample of soil obtained near the outer edge of the pavement. Climatic, atmospheric, and construction conditions may cause a greater fluctuation in moisture content beyond the outer edge of the pavement than occurs beneath the pavement.

In order for the calibration curves to have maximum reliability, the condition of the soil adjacent to the cell should be identical in both the calibration and field installations. As stated previously, the cells in the field were embedded in soil having sufficient moisture to form a slurry, and the remainder of the soil surrounding the embedded cell was tamped to approximately the same density as the adjacent subgrade. In calibration of the cells it was necessary to obtain cell-resistance readings at several moisture contents and densities for each soil. If the calibrated cells had been embedded in the same manner as those in the field, considerable time would have been required to obtain resistance readings at relatively low moisture contents, and it would have been difficult to determine the density of the soil immediately surrounding the cell.

The soil densities given in Table 29 are based on the assumption that the soil is 90 percent saturated, and the cell moisture content is obtained from the calibration chart by using the density corresponding to that percentage saturation. In reality, the soil adjacent to the cells may not have an average saturation of 90 percent and there is undoubtedly some periodic variation in the percentage saturation.

Soil temperature readings have not been made, but it is probable that some of the cell resistance readings were made when the soil was near the freezing temperature. The calibration curves are corrected to 70 F. If the cell resistance reading is 300 ohms when the temperature of the soil is 32 F., the corrected resistance will be 210 ohms at 70 F. Reference to the 105-pcf. curve of Figure 34 shows that this difference in resistance corresponds to a moisture content difference of 1.0 percent.

There may be some difference in cells, either in their original construction or due to weathering influences. It has been noted that the minimum resistance which can be obtained when the cell has been immersed in water for a long period is normally about 60 ohms. In field installations, several cells have had resistance readings of less than 60 ohms during two or more consecutive months.

In order to eliminate some of the sources of error in the determination of the moisture content corresponding to the cell resistance, an attempt was made to prepare calibration curves based on the resistance readings and actual moisture contents obtained in the field. However, these calibration curves are unreliable because all of the sources of error described for the laboratory calibration method are also inherent in the field calibration. Since soil density has a major influence on the cell resistance, particularly in the low resistance range, and the density of the soil adjacent to the cell was not determined in the field installations, the subgrade moisture contents determined from the field calibration show a greater variation from the actual moisture content than when determined by use of the laboratory calibration curves. Consequently, neither the field calibration curves nor the corresponding subgrade moisture content data are included in this report.

In general, there has been a gradual reduction in electrical resistance of all cells for a period of several months following field installation, after which the resistance was relatively constant except for those periods when the ground was frozen. This trend is illustrated in Figures 35 and 36.

A summary of the resistance readings of the cells located in the subgrade is given in Table 30 for the periods during which the resistance was relatively constant. Since there is considerable periodic variation in resistance for the same cell, as well as a difference in average resistance for cells placed at the same depth under the same type and thickness of subbase, the limited number of installations beneath each type of sub-

base do not permit comparison of resistance of the subgrade beneath the various types of subbase. However, there are sufficient cells installed at the various depths that a comparison of the average resistance at specific subgrade depths is warranted.

The average resistances were 189, 250, and 223 ohms for all cells at subgrade depths of 1/2, 6, and 12 inches, respectively. The average resistances at 0.5 ft. right of the pavement centerline were 211, 209, and 193 ohms for the cells at depths of 1/2, 6, and 12 inches, respectively, while at 11.0 ft. right of the centerline, the averages

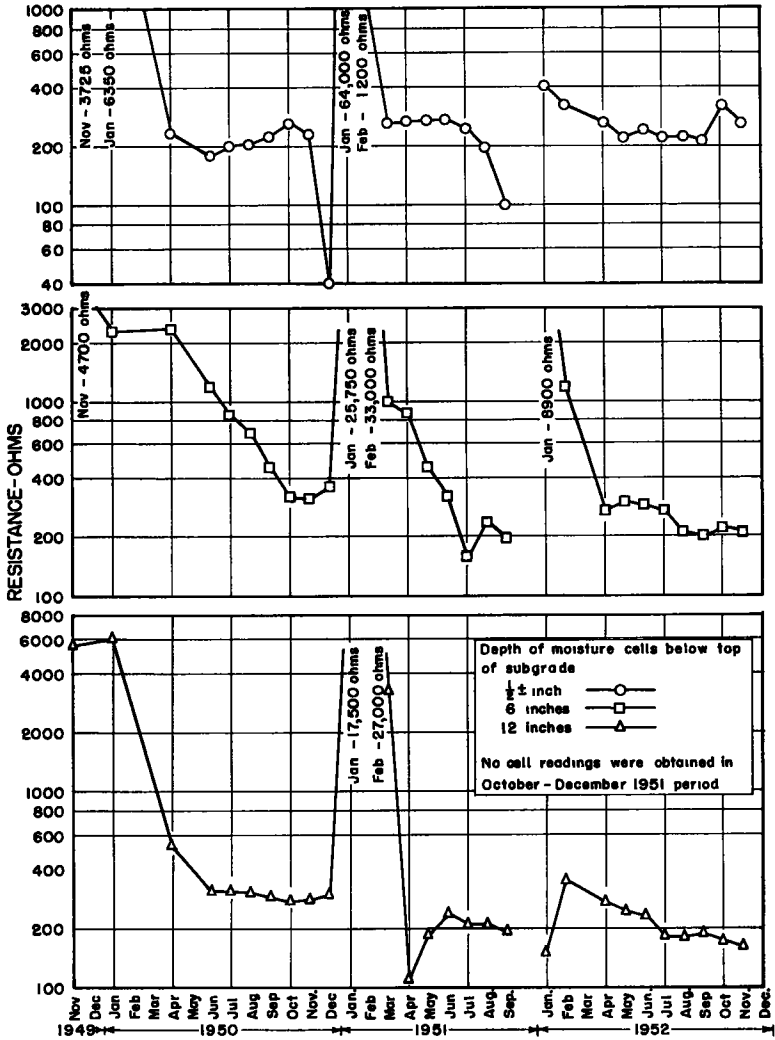

Figure 36. Moisture-cell readings, November 1949 to November 1952, for cell installation in subgrade 0.5 foot right of centerline or pavement, Station 324+09.4. 3-inch soil-cement subbase section.

were 171, 286, and 247 ohms.

These averages indicate a tendency for the resistance to be slightly lower at the top of the subgrade near the outer edge of the pavement than at other cell locations. The averages also indicate that at 0.5 ft. right of the centerline, the resistance is about the same at the three depths and that at 1/2-in. depth, the resistance is greater near the centerline than near the edge of the pavement. However, disregarding the average reading of 481 ohms for the cell at 1/2-in. depth, 0.5 ft. right of centerline at station 520+28.5, which is at the midpoint of a 40-ft. panel of reinforced concrete pavement,

the average for the cells at $\frac{1}{2}$ -in. depth near the centerline becomes 169 ohms. Thus, for cells near the contraction joints, there is a tendency for the resistance to be slightly lower near the top of the subgrade than at greater depth.

Table 30 shows that many of the cells, particularly at $\frac{1}{2}$ -in. depth in the subgrade, have had a minimum resistance reading of 60 ohms or less. Most of the cells tested in the laboratory have a resistance of about 60 ohms after they have been soaked in water for long periods. Thus, the subgrade soil has become saturated at many of the cell locations.

The minimum cell readings also indicate that the upper portion of the subgrade tends to attain a higher moisture content than at greater depth. The average minimum resistances are 77, 127, and 128 ohms at depths of $\frac{1}{2}$, 6, and 12 inches, respectively.

These small differences in average resistance are relatively insignificant, if the soils at the various depths and lateral positions have the same density. For example, using Figure 34, for a dry density of 110 pcf., the moisture content corresponding to a resistance of 170 ohms is 19.2 percent, while at 250 ohms it is 18.7 percent, or a variation of 0.5 percentage point in moisture content. However, if the upper portion of the subgrade has a density of only 105 lb., the moisture content corresponding to 170 ohms resistance is 20.9 percent.

The resistance of the cells placed at depths of 6 and 12 inches in the open ground varied with the climatic condition, hence the readings are not reported. For example the cell at a depth of 6 in. had a resistance of 38,000 ohms in August 1951 and 670 ohms in September 1951.

Figures 37 and 38 show there is a seasonal trend in the resistance of the cells placed at depths of 18, 24, 36, and 48 in. in the open ground. The resistance decreases to a low value in the winter and continues relatively constant for several months, after which it increases considerably, then remains relatively constant at the high value during the late summer, autumn, and early winter. The increase in resistance occurs earlier at the shallower depths and the maximum resistance varies inversely with the depth.

TABLE 30
ELECTRICAL RESISTANCE OF MOISTURE CELLS IN SUBGRADE, JUNE-NOVEMBER 1950,
APRIL-SEPTEMBER 1951, AND APRIL-NOVEMBER 1952

Section	Thickness and type of subbase	Location of cell		Electrical resistance of cells					
		Station	Distance right of centerline	$\frac{1}{2}$ inch below subbase		6 in. below subbase		12 in. below subbase	
				Range	Average	Range	Average	Range	Average
			feet	ohms	ohms	ohms	ohms	ohms	ohms
1-E	3-inch soil-cement	324+09.4	0.5 11.0	100-320 95-360	230 182	160-1180 140-300	401 197	110-310 110-830	226 310
1-F	5-inch soil-cement	327+54.4 327+61.7	11.0 11.0	40-210 45-620	100 206	200-960 240-590	542 395	110-450 120-1360 ¹	247 457 ¹
2-D	No subbase	362+27.7	0.5 11.0	60-440 210-370	223 ^a 287	190-440 230-680	265 376	240-630 180-530	361 267
2-M	5-inch open-graded stone	398+17.3	0.5 11.0	50-500 60-260	161 ^b 132	140-410 d	202 ^c d	d d	d d
3-B	5-inch dense-graded stone	441+97.4	0.5 11.0	40-430 75-280	115 ^e 174	65-130 270-720	114 409	110-400 180-480	182 297
4-H	5-inch open-graded stone (drained joint)	474+84.4	0.5 11.0	40-310 75-240	108 ^e 124 ^f	50-275 90-210	147 121	120-360 125-205	182 153
4-H	5-inch open-graded stone (undrained joint)	475+24.4	0.5 11.0	65-200 80-330	111 142	175-455 150-280	268 192	100-385 130-260	185 161
4-B	5-inch dense-graded stone	520+09.5	0.5 11.0	140-560 110-340	229 181 ^g	50-250 50-200	126 101	45-160 180-390	101 233
4-B	5-inch dense-graded stone	520+28.5	0.5 11.0	60-900 40-520	481 178 ^h	50-280 40-450	140 ^e 237	80-170 100-295	114 164
Average at 0.5 ft. right of centerline				69-418	211	110-427	209	115-345	193
Average at 11.0 ft. right of centerline				83-353	171	157-488	286	137-533 ¹	247 ¹
Average for all cells				77-400	189	127-459	250	128-451 ¹	223 ¹

^a Three readings in 1951 questionable and disregarded

^b Five readings in 1950 questionable and disregarded

^c April 1952 reading questionable and disregarded

^d All readings questionable and disregarded

^e Two readings in 1950 questionable and disregarded

^f Three readings in 1950 and two in 1951 were disregarded

^g Two readings in 1950 and four in 1951 were disregarded

^h Two readings in 1952 questionable and disregarded

¹ Excluding all 1950 readings

^j Excluding 1950 readings for cells in Section 1-F, 12 inches below subbase, 11.0 feet right of centerline

Although some of the change in resistance of the cells placed in the open ground is due to changes in moisture content, part of the change may be due to variations in density of the soil or soil-contact with the cell. Moisture-content determinations on samples obtained adjacent to the cells indicate that during both the low- and high-resistance periods there may be a considerable change in moisture content while the resistance

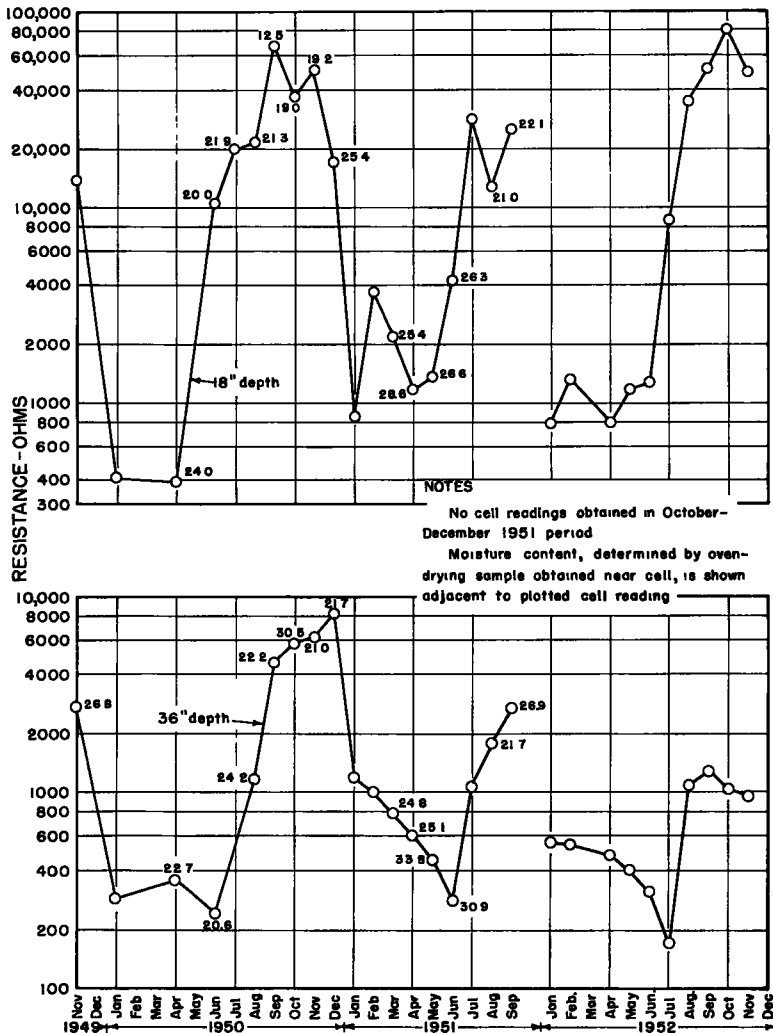

Figure 37. Moisture-cell readings, November 1949 to November 1952, for cells at depths of 18 and 36 inches in open ground, 54 feet right of centerline of pavement, Station 449+00.

remains relatively constant. However, for each cell the average moisture content, determined adjacent to the cell, tends to be slightly lower during the period of high cell resistance than when the resistance is low. The moisture contents are shown in Figures 37 and 38.

Laboratory calibration curves have not been prepared for moisture cells in the stone subbase materials, hence the resistance readings for cells placed in the subbases are not discussed in this report.

Based on the data obtained in the field and in the laboratory, it is evident that if the Bouyoucos cells are used for moisture content determination, the soil density must be determined simultaneously with the cell reading.

Although a temperature slightly greater or less than that at which the cell was calibrated only slightly affects the resistance, particularly in the low-resistance range, soil-temperature readings should also be made simultaneously with the resistance readings, in order to determine the seasonal variation in moisture content of the soil.

SUMMARY

The purpose of the experiment is to determine the effectiveness of various types and thicknesses of subbase in the control of pumping of plain and reinforced concrete pave-

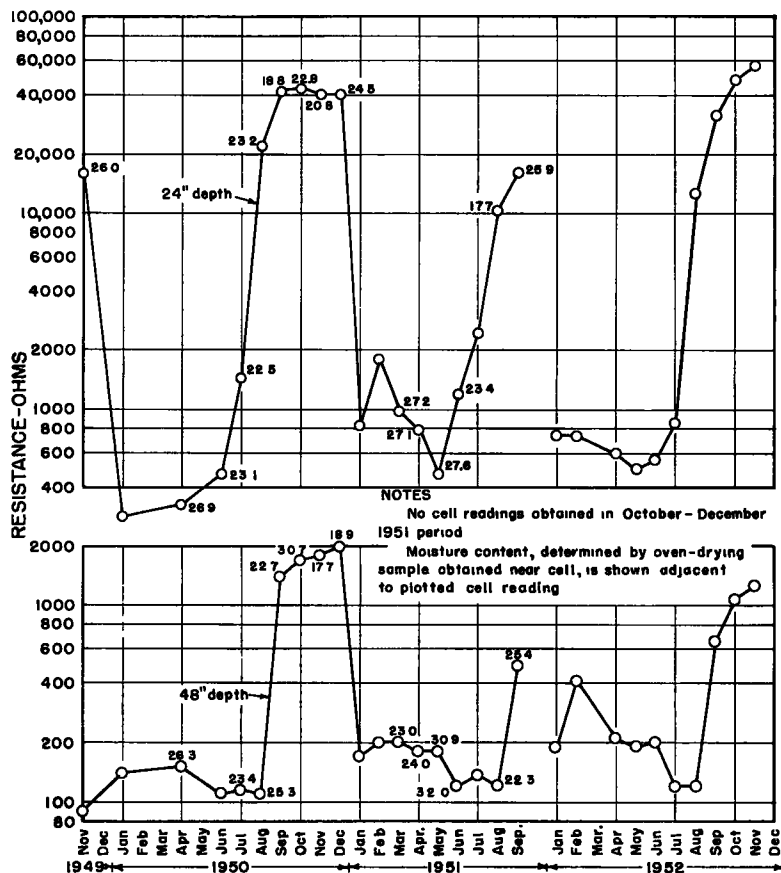

Figure 38. Moisture-cell readings, November 1949 to November 1952, for cells at depths of 24 and 48 inches in open ground, 54 feet right of centerline of pavement, Station 449+00.

ments constructed on fine-grained soils.

Each of the four miles in the experimental project has eight subbase sections, as follows: (1) two of soil-cement, with thicknesses of 3 and 5 inches; (2) three of open-graded crushed stone, with thicknesses of 3, 5, and 8 inches; and (3) three of dense-graded crushed stone, with thicknesses of 3, 5, and 8 inches. One control section in each mile has no subbase.

The dense-graded stone and soil-cement subbases were constructed in trench sections extending one foot beyond each edge of the pavement, and no lateral drains were provided. In two miles, the open-graded stone subbase extends two feet beyond each edge of the pavement and has lateral drains. In the other two miles, the open-graded stone subbase extends the full width of the roadway (shoulder slope to shoulder slope).

The concrete pavement has a 9-8-9-in. thickened edge section and is 24 ft. wide. The first and third miles have plain concrete with contraction joints spaced 15 feet.

The second and fourth miles have reinforced concrete with contraction joints spaced 40 feet.

The soils in the upper 3 ft. of the subgrade are in the A-6 and A-7-6 groups. The soils in the upper 6 in. are predominantly in the A-6 group, with group indexes greater than 6.

All portions of the subgrade were compacted to at least 95 percent of the maximum dry density determined by the standard compaction test. The average relative compaction of the upper 6 in. of the subgrade was 104 percent just prior to construction of the subbases. Tests made just prior to paving indicated the subgrade had an average relative compaction of 107 percent.

Subgrade soils which ranged from A-6(8) to A-6(12) had laboratory California bearing ratio values ranging from 4 to 6 when compacted to the maximum dry density obtained by the standard method of compaction and soaked for four days. When compacted to the maximum dry density obtained by the modified compaction method, the CBR values ranged from 11 to 23. The in-place CBR values for the subgrade, determined just prior to paving, ranged from 2 to 46.

The ranges in soil strength characteristics, determined from triaxial compression tests on undisturbed samples of subgrade soil, were as follows: Cohesion - 12 to 14 psi.; angle of internal friction - 7 to 32 degrees; modulus of elasticity - 970 to 2780 psi.; and subgrade modulus - 50 to 160 psi. per inch.

Bouyoucos moisture-cells, of the nylon-fabric type, installed in the subgrade indicate that (1) the resistance of the cells becomes relatively constant several months after installation, then remain constant except for periods when the subgrade is affected by freezing and (2) that the resistance tends to be slightly lower in the upper portion of the subgrade than at greater depth. However, before the cell readings can be used to determine the moisture content of the soil, the density and temperature of the soil must be known. Further correlation of data obtained from the field installation is necessary before it can be determined that the adopted method of calibrating the cells is adequate.

The soil used in three sections of soil-cement subbase was classified as A-6(11) while that used in the remaining five sections was A-7-6(13). The cement content, by volume, for two of the sections was 15 percent, and was 14 percent for the other six sections.

The material used in the crushed stone subbase was well-graded and only material smaller than $1\frac{1}{2}$ in. was used. The average percentage passing the No. 200 sieve was 3.3 for the open-graded type and 10.7 for the dense-graded type. The average coefficient of permeability, in ft. per day, of the compacted open-graded stone was 18, and was 0.7 for the dense-graded stone. The average relative compaction was 101 percent for each of the two types of granular subbase, and the minimum was 95 percent.

Single-axle loads in excess of 10,000 lb. passing over the experimental project decreased from 800 per day in 1950 to 739 per day in 1952 but increased to 798 in 1953, while tandem-axle loads in excess of 16,000 lb. increased from 225 per day in 1950 to 340 in 1953.

In November 1949, immediately after the pavements were constructed, the average roughness index in the traffic lane was 140 in. per mile for the plain concrete pavement placed on subbases and 123 in. per mile for the reinforced concrete pavement. The initial roughness index, in inches per mile, in the traffic lane of pavements without subbase was 135 for the plain concrete and 124 for the reinforced concrete. By December 1953, the average roughness index in the traffic lane, in inches per mile, had increased 44 for the plain concrete and 13 for the reinforced concrete pavement placed on subbases. The average roughness increase in the traffic lane for sections built without a subbase was 90 in. per mile for the plain concrete and 18 for the reinforced concrete pavement.

Excluding the sections without a subbase, the average section profile changes at the outer edges, quarter-points and centerline of the 24-ft. pavement have been less than 0.05 ft., except for those in February 1951 when the subgrade was frozen.

The greatest changes in pavement elevation have occurred in the sections without subbases. Section 2-D, reinforced concrete pavement, showed the greatest movement. The average decrease in elevation at the center of the traffic lane of this section, determined at 12 level points, was 0.028 ft. and the level-point changes ranged from 0.024

ft. above to 0.097 ft. below the 1949 elevation. Eight level points at the outer edge of one 160-ft. portion of this section showed an average decrease in elevation of 0.084 ft.

By December 1953, a transverse crack had occurred in four panels of the traffic lane of the plain concrete pavement, in sections without a subbase. At that same time, 96 percent of the panels in the reinforced concrete pavement in the traffic lane and 91 percent in the passing lane had at least one transverse crack in the middle half of the panel, but these cracks have remained closed.

Pumping has not occurred at any of the contraction joints or cracks in the reinforced concrete pavement, and there has been no extrusion of material at the edges of either of the two types of pavement in the sections having an open-graded stone subbase.

Some pumping has occurred along the outer edge of the reinforced concrete pavement in sections having no subbase.

Granular material has been extruded along the outer edge of the pavement in all sections having dense-graded stone subbase.

Soil-cement material has been extruded at some of the joints in the plain concrete pavement and at the outer edge of the pavement in all sections having soil-cement subbases.

In the traffic lane of sections having plain concrete pavement and no subbase, there has been active pumping at every joint and along the outside edge of the slabs. Minor faulting occurred at some joints in 1953. The pavement in these sections was sub-sealed with asphalt in July 1953 to prevent excessive pavement failure. However, excessive pumping and progressive faulting continued at some joints during the winter of 1953-54, resulting in the formation of a transverse crack in four panels.

Further observations for a period of several years will be necessary to determine the relative effectiveness of the various types and thickness of subbase in the control of pumping.

CONCLUSIONS

Although further observations will be necessary to determine the relative effectiveness of the various types of subbase in the control of pumping, the following conclusions are indicated at this time:

1. There is a sufficient volume of heavy-axle load traffic on the experimental pavement to cause pumping. Limited pumping has occurred at either the outer edge of the pavement or at the contraction joints in all sections except those having open-graded stone subbase.
2. The pavement sections having plain concrete, 15-ft. joint spacing and no subbase, have shown distress which is due to pumping.

FUTURE RESEARCH

In addition to a continuation of the observations of performance of the pavements as described in this report, the cooperative agreement was expanded in 1953 to include the measurement of deflections and strains in the concrete pavement. Under an agreement with the state, the Joint Highway Research Project, Purdue University, is developing the necessary strain-measuring equipment. After pilot studies of strain measurements have been made for representative slabs of concrete pavement under different vehicle loadings and speeds, deflection and strain measurements will be made on each type of pavement constructed on each type of subbase, as well as on the pavement sections without subbase.

References

1. "Final Report of Project Committee No. 1, Maintenance of Concrete Pavement as Related to the Pumping Action of Slabs." Proceedings of Highway Research Board, December 1948.
2. "A Survey of Pumping in Ohio." Ohio Department of Highways, March 1, 1951.
3. "Performance of Concrete Pavement on Granular Subbase." Bulletin 52, Highway Research Board, 1952.

4. "The Formation, Distribution and Engineering Characteristics of Soils," by D. J. Belcher, L. E. Gregg and K. B. Woods. Bulletin 87, The Engineering Experiment Station, Purdue University, 1943.
5. "Nylon Electrical Resistance Unit for Continuous Measurement of Soil Moisture in the Field." By G. J. Bouyoucos, Soil Science, Vol. 67, No. 4, April 1949.
6. "The Theory of Stresses and Displacements in Layered Systems and Applications to the Design of Airport Runways," by D. M. Burmister, Proceedings of Highway Research Board, 1943.
7. "A Fabric Absorption Unit for Continuous Measurement of Soil Moisture in the Field," by G. J. Bouyoucos and A. H. Mick, Soil Science, Vol. 66, No. 3, September 1948.
8. "Observations of Moisture Contents and Densities of Soil Type Base Courses and Their Subgrades," by L. D. Hicks, Proceedings of Highway Research Board, 1948.
9. "Subgrade Moisture Conditions Beneath Airport Pavements," by M. S. Kersten, Proceedings of Highway Research Board, 1945.

Report on Pavement Research Project in Ohio

CHARLES W. ALLEN, Engineer of Research, Ohio Department of Highways; and
L. D. CHILDS, Senior Development Engineer, Portland Cement Association

This project was built in the summer and fall of 1952 in an attempt to determine the performance of various thicknesses of subbase on a main truck route. The project is four miles long, of 9-in. uniform thickness, and is 24 ft. wide. It is divided into four sections, two with contraction joints on 100-ft. centers and two with contraction joints on 20-ft. centers.

The four sections are divided into subsections using the following types of subbase: (1) control with no subbase, subgrade is a known pumping soil; (2) open-textured granular subbase material, 3, 5, and 8 inches thick; (3) dense-graded granular subbase material, 3, 5, and 8 inches thick; (4) cement-modified soil 6 inches thick, with cement contents of 5, 7, 9, and 11 percent; and (5) soil-cement mixture 3 and 5 inches thick.

Eighteen 24-hr. traffic counts made since the project was constructed show that the test lanes carry approximately 1,844 combination trucks in 24 hours. Many of these have axle loads exceeding 18,000 lb.

● THE Department of Maintenance, in its "Final Report of Project Committee No. 1, Maintenance of Concrete Pavement as Related to the Pumping Action of Slabs," (1) recommended that future research be conducted to investigate the thickness and characteristics of subbases necessary to prevent pumping of portland-cement-concrete pavements placed over potentially pumping soils, and the relationship of traffic and slab end deflections to pumping.

The Bureau of Public Roads recommended a continuation of the study, and several states were invited to participate by constructing test roads which would incorporate features particularly suitable for this investigation.

The Ohio Department of Highways and the Bureau of Public Roads cooperated in the construction of such a test road in the summer and fall of 1952. These two organizations and the Portland Cement Association are cooperating in the testing.

While this report is concerned mainly with the construction of the test road, the performance observations made to date are included although it is much too early to attempt to draw any conclusions from them.

DESIGN AND CONSTRUCTION

Project Location

The report of the project committee showed conclusively "that the repeated passage of heavy axle loads is the primary activating element in pumping at joints and cracks in concrete pavements" and that "free water and fine-grained subgrade soils are the other two contributing factors." Therefore, it was essential that the test road be constructed where the subgrade soil was conducive to pumping and where the anticipated number of heavy axle loads would be sufficient in magnitude to assure that these elements which are known to cause pumping were present.

The location finally selected for the Ohio test road was approximately four miles of the eastbound roadway of US 20 in Sandusky County between Fremont and Clyde. Being a part of a main route east of Toledo, the road carries a large number of freight vehicles many of which haul heavy loads.

Construction Specifications

In general the specifications under which this test road was constructed were the "State of Ohio, Department of Highways, Construction and Material Specifications," dated January 1, 1951. Certain additions and modifications of these specifications, which are included in the following paragraphs, were necessary so that a complete record of the materials that went into its construction and the in-place condition of the

TABLE 1
STRENGTH OF PAVEMENT CONCRETE

Type of Specimen	Age, Days	No of Tests	Strengths	
			Compressive, psi	Modulus of Rupture, psi
Cylinders	7	97	3,456	-
Cylinders	28	110	4,757	-
Cores	28 ^a	68	4,852 ^a	-
Beams	3	117	-	609
Beams	5	128	-	632
Beams	7	228	-	652

^aThe cores were cut and tested at various ages ranging from 2 $\frac{1}{4}$ to 7 $\frac{1}{2}$ months. The average age was 6.07 months and the average strength was 5,794 psi. The equivalent 28-day strength is given in the table.

using full width construction. The test road was divided into four sections, each approximately 6,500 ft. in length. In the first and third sections the contraction joints were spaced at 100-ft. intervals, while in the second and fourth sections, they were spaced at 20-ft. intervals. Expansion joints were only used between sections and on each side of the one major bridge. All of the joints have load transfer devices.

The materials used in the concrete were crushed-limestone coarse aggregate, manufactured sand, and portland cement entraining 3 to 6 percent of air, each from one approved source.

The results of tests of beam and cylinder specimens cast at the time of construction are shown in Table 1.

Subgrade

In order to insure a reasonably uniform subgrade within the limits of what is known to be a pumping soil, the upper foot of the subgrade was required to conform to the following gradation:

Aggregate retained on a No. 200 sieve (0.075 mm.)	0 - 60% ^a
Silt (0.075 mm. to 0.005 mm.)	0 - 85%
Clay (smaller than 0.005 mm.)	15 - 100%

^a If the plus No. 200 mesh sieve aggregate exceeds 45 percent, the silt content shall not exceed 15 percent and the clay content shall not exceed 40 percent.

The characteristics of the upper foot of the in-place subgrade were obtained by the sampling of each 500-ft. length of roadway, a complete summary of which is given in Table A (appendix). The upper foot of the subgrade soil ranges between A-6(8) and A-6(12) of the AASHTO Designation M145-49, with the exception of a small quantity of A-7-6(13) material. A table of ranges and averages which characterize the material is listed in Table 2.

TABLE 2
RANGES AND AVERAGES OF
SUBGRADE CONSTANTS

Classification	Range	Ave. Value
Passing No. 10	89% - 100%	95%
Passing No. 200	63% - 92%	77%
Silt	31% - 55%	43%
Clay	29% - 45%	36%
Liquid Limit	30 - 42	35
Plasticity Index	12 - 22	16

subgrade, subbase, and surface course might be available for future study.

When any course of any 500-ft. subsection was completed, the contractor was required to allow the project engineer up to three working days in which to make in-place tests of the completed course.

Pavement

The pavement was built of mesh reinforced air-entrained portland-cement concrete. It has a 9-in. uniform thickness and is 24 ft. wide. The concrete was placed

Subbase

Each section, except the fourth, is divided into twelve different subbase treatments and one length of no subbase. These subsections are 500 ft. long and consist of: (1) open-textured granular subbase material, 3, 5, and 8 inches thick; (2) dense-graded granular subbase material, 3, 5, and 8 inches thick; (3) soil-cement, 3 and 5 inches thick; and (4) cement-modified soil, 6 inches thick, with cement contents of 5, 7, 9, and 11 percent.

The fourth section is divided into only 11 subbase treatments, the 11 percent cement-modified subsection being omitted. The

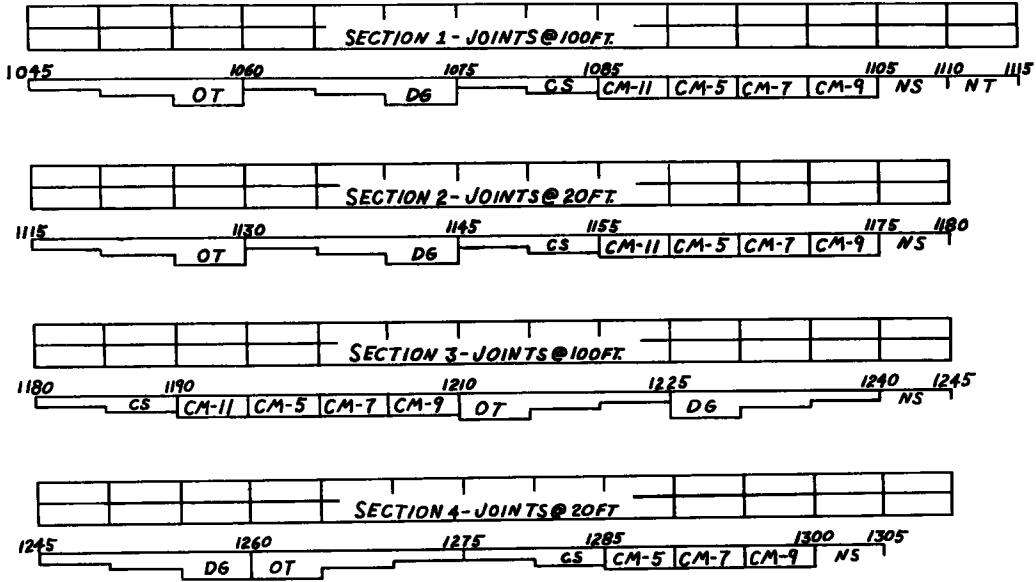
**LEGEND**

OT = Open Textured - 3", 5", 8"
 DG = Dense Graded - 3", 5", 8"
 CS = Cement Stabilized - 3", 5"
 CM = Cement Modified Soil - 6"
 5, 7, 9, 11 % Cement
 NS = No Subbase
 NT = No Test

Figure 1. Arrangement of subbase treatments on the Ohio subbase test road.

specific arrangement is shown in Figure 1.

The material used for the open-textured granular subbase was crushed limestone. The specifications required that the coefficient of permeability be not less than 500 feet per day and that the grading conform to the following:

Sieve Size	Total Percent Passing
1½ in.	100
1 in.	50-100
No. 4	30-100
No. 40	0-35
No. 200	0-15

The material used for the dense-graded granular subbase was also crushed limestone. The coefficient of permeability was required to be not greater than 2 feet per day and the grading was required to conform to the following:

Sieve Size	Total Percent Passing
1½ in.	100
1 in.	95-100
No. 40	20-65
No. 200	15-30

A brief summary of the average characteristics of these granular subbase materials is given in Table 3. Characteristics of samples from each treatment are listed in Table B in the appendix.

The soil for the soil-cement subbase met the grading requirements of the upper foot of the subgrade. The pulverized soil was required to have a minimum of 80 percent of the mixture by weight passing a No. 4 sieve, exclusive of the gravel or stone retained

TABLE 3
CHARACTERISTICS OF GRANULAR SUBBASE

Subbase Treatment and Soil Classification	Gradation Total Percent Passing			Permeability Coefficient, Ft./Day	AASHO Max. Dry Density, Pcf.	Optimum Moisture, %
	No. 4	No. 40	No. 200			
Open-textured A-1-a(0)	38	11	7	590	125	12
Dense-graded A-1-b(0)	99	36	22	0.21	128	11

on a No. 4 sieve. The soil-cement contained 14 percent cement by volume. A soil-stabilizing machine was used to pulverize the soil, spread the cement and water, mix the materials and spread the mixture. For the initial compaction, a tamping roller was required. A smooth-wheeled tandem roller and pneumatic tired rollers were required for final compaction. The contractor was required to cure the completed course with earth or saturated straw for a minimum of 7 days or until the portland-cement concrete was placed on the subbase.

When tested in accordance with the requirements of the Standard Method of Freezing-and-Thawing Test of Compacted Soil-Cement Mixture, AASHO Designation T 136-45, representative soil-cement cylinders showed a loss after 12 cycles of 5 percent. Cylinder strengths from 2-by-2-in. representative soil-cement cylinders are as follows:

Age, days	Strength, psi.
2	254
7	350
28	497

The cement-modified soil subbase and the soil-cement subbase were constructed of the same materials and by the same methods except that for the cement modified subbase a minimum of 70 percent cement pulverization was permitted and no curing was required.

The effect of cement modification of the soil is shown by the data in Table 4.

TABLE 4
EFFECT OF CEMENT MODIFICATION
CN SOIL CHARACTERISTICS

Cement Content	0%	5%	7%	9%	11%
Physical Constant	Numerical Value of Constant at Cement Contents Listed Above				
Liquid Limit	39	39	37	37	36
Plastic Limit	19	25	25	27	29
Plasticity Index	20	14	12	10	7
Shrinkage Limit	19	25	26	28	32
Soil Classification	Percent in Each Classification at Above Cement Contents				
Coarse Sand	4	20	24	26	31
Fine Sand	14	18	18	25	22
Silt	39	38	36	34	32
Clay	42	23	21	14	14

A brief summary of the average characteristics of both of the cement-treated subbases is given in Table 5. Characteristics of samples from each treatment are listed in the appendix.

OBSERVATIONS OF PERFORMANCE

General

Observations of the performance of the various subbase treatments will probably continue for several years. Traffic studies, records of moisture and temperature changes, pavement deflections studies, studies of pavement strains and visual observations of distress are being made at the present time.

Traffic Studies

The Ohio Highway Department began making traffic counts and weight surveys of the vehicles using the test road in

TABLE 5
CHARACTERISTICS OF CEMENT TREATED SUBBASES

Subbase Treatment	Max. Lab. Dry Wt. (Incl. Cem.), Pcf.	Max. Lab. Wet Wt. (Incl. Cem.), Pcf.	Wet Wt. as Placed Pcf.	Opt. Moist., %	Moist. as Placed, %
Soil-cement	105.8	126.4	125.0	18.8	19.5
Cement-modified	106.0	126.8	125.2	18.7	19.3



Figure 2. Deflectometer installation.

January, 1953. With a few exceptions traffic counts and weight surveys have been made monthly since that time. These traffic studies indicate that the test road is well located with respect to traffic loads and frequency. On an average yearly weekday 5,749 vehicles pass over the test road. Of this amount 2,130 are heavy trucks. Based on weight surveys, 21 percent of the axles of the heavy trucks weigh more than 14,000 lb. The results of these monthly traffic counts and weight surveys will be found in the appendix.

Moisture and Temperature Records

Provisions were made during construction for the installation of fibreglas electrical soil-moisture instruments which contain thermistors for temperature determinations also. A discussion of the basic design of this instrument can be found in "The Place of Electrical Soil-Moisture Meters in Hydrologic Research," by E. A. Colman (2). Improvements in this basic design had been made in the instruments used. These improvements are discussed in "The Fibreglas Soil-Moisture Instrument," by E. A. Colman and T. M. Hendrix (3).

These fibreglas soil-moisture cells were installed in the subbase and subgrade beneath the pavement at each of seven locations along the test road. In addition four of the cells were placed along the right-of-way line at various depths so that the effect of the pavement slab might be observed. The Ohio Department of Highways and the Bureau of Public Roads are cooperating in the interpretation of the data being obtained from these cells.

TABLE 6
MAXIMUM DEFLECTIONS RECORDED IN JULY 1953
(Deflections in Thousandths Inches)

Subbase Type	20 Foot Slabs				100 Foot Slabs			
	Joints		Midslabs		Joints		Midslabs	
	t = 15	t = 15 t = 13	t = 2	t = 2	t = 12	t = 12	t = 15	t = 1
3in O T	10	11	14	18	20	20	13	26
5in O T	9	9	10	14	15	16	13	23
8in O T	13	14	14	23	17	9	8	13
3in D G	14	15	17	18	38	20	14	19
5in D G	11	13	12	15	24	9	9	17
8in D G	12	10	12	14	26	12	11	18
3in S C	11	11	13	16	23	13	10	15
5in S C	8	8	10	14	12	11	9	12
5% C M	8	14	16	25	16	12	9	14
7% C M	8	13	14	21	15	12	8	17
9% C M	8	11	7	11	13	12	8	15
11% C M	9	8	10	21	14	12	10	17
N S	23	22	21	20	99	20	16	18

t = Temperature of top of slab minus temperature of bottom of slab

Only two of the four test sections are instrumented for these tests, namely, the second and third sections which have 100-ft. and 20-ft. joint spacings, respectively.

The loading truck being used in these studies is a 3-axle dump truck loaded to a gross of approximately 31,500 lb. on the tandem axles.

In the general evaluation study only the maximum deflections are desired. They are being obtained by measuring the relative displacement between the slab edge and the top of a rod driven through a casing into the subgrade. The deflectometer used to measure slab deflections with respect to the rod is shown in Figure 2. In each subsection of the two sections selected for study there are deflectometer installations at the midpoint of three slabs and within 6 inches of each side of one joint.

The maximum deflection data that has been obtained to date is summarized in Tables 6 and 7. The figures representing corner deflections are averages of three runs at each of two adjacent corners and those in midslab columns are averages of three runs at each of three positions at the pavement edge midway between joints.

The effect of temperature upon the magnitude of panel deflections is very noticeable. In Table 7, under 100-foot slabs, the tests made in the early morning with a slab differential, temperature of top of slab less temperature of bottom of slab, of 0 F. gave corner deflections about twice as large as those made in the afternoon with a slab differential of +12 F. The same trend is observed under 20-foot slabs but the differences between early morning deflections and afternoon deflections are not quite as large.

From the maximum deflection data obtained thus far, it is quite evident that all of the subbases are of some value in the reduction of slab deflection below that found in the no-subbase sections. Thus far, of those being tested, the most effective in the reduction of slab deflection are the cement-modified subbases. Next in rank are the soil-cement subbases and the least effective are the open-textured and dense-graded subbases.

To ascertain the magnitude of strains in the portland-cement-concrete road slabs associated with the slab deflections, several of the installations for maximum deflections have been selected for further study and these are instrumented to provide a continuous strain and deflection record for each pass of the test vehicle.

The linear variable differential trans-

Deflection and Strain Studies

Two types of deflection studies are being made. The first is an overall evaluation program in which a controlled load moves past an arrangement of maximum reading deflectometers. The arrangement is such that the maximum deflections of the outer corners and edges of several slabs in each treatment on one section are recorded within a short interval of time. This method serves to reduce the effects on deflection readings of changes in the shape of the slab due to temperature differences.

A second type of study is being made at a limited number of locations. At these positions, deflections and strains are read continuously during the passage of the load.

TABLE 7
MAXIMUM DEFLECTIONS RECORDED IN APRIL 1954
(Deflections in Thousandths Inches)

Subbase Type	20 Foot Slabs				100 Foot Slabs			
	Joints		Midslabs		Joints		Midslabs	
	t = 4	t = 10	t = 0	t = 1	t = 0	t = 12	t = -1	t = 12
3in O T	34	27	20	17	38	19	29	13
5in O T	28	18	16	10	34	13	32	14
8in O T	47	22	24	16	36	12	23	10
3in D G	36	19	20	17	60	30	24	21
5in D G	29	15	17	13	29	14	20	15
8in D G	28	20	19	13	36	19	23	14
3in S C	41	23	21	15	62	38	18	15
5in S C	40	16	18	10	30	18	16	14
5% C M	38	23	27	20	27	12	13	11
7% C M	28	17	24	16	42	15	17	11
9% C M	30	17	15	10	38	15	15	11
11% C M	31	19	17	11	29	19	15	14
N S.	53	35	20	20	103	78	25	21

t = Temperature of top of slab minus temperature of bottom of slab

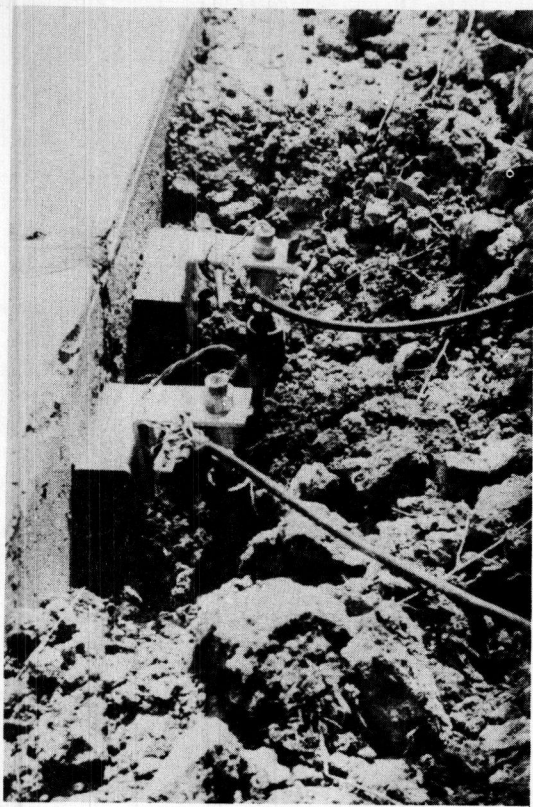

Figure 3. Transformer installation.

formers being used for the continuous deflection measurements are mounted in a manner similar to the maximum reading deflectometers. The housing is held in an angle bracket which is clamped to the uni-strut section and the iron core pin rests on the top of the reference rod which was driven through the casing into the subgrade. They are coupled directly to a Sanborn automatic strain recorder. A view of the transformers installed at a joint is shown in Figure 3.

For the measurement of strains for the continuous record study Baldwin SR-4 Type A-9 gages are cemented to the upper surface of the portland-cement concrete close to the edge. The Sanborn recorder indicates these strains simultaneously with the deflections indicated by the transformers.

One of the SR-4 Type A-9 gages is mounted midway between the ends of the slab and two gages are placed at a distance from the corner which has been found by trial to be the position giving maximum response with corner loads. These positions have been found to be $4\frac{1}{2}$ feet from the joint in 20-foot panels and 8 feet from the joint in 100-foot panels. The distances are not critical.

A summary of maximum deflections and strains from the tests made to date is presented in Table 8. No constant temperature differential could be attained in these tests due to time requirements.

When the truck wheels were crossing the joint, the maximum tension in the upper face of the concrete slab was seldom as large as the maximum compression recorded

TABLE 8
MAXIMUM STRAINS AND DEFLECTIONS FROM CONTINUOUS RECORDS

Subbase Type	1953 Deflections (.001 in.)				1953 Strains (.000001 in./in.)			1954 Deflections (.001 in.)			1954 Strains (.000001 in./in.)			
	t	Corner App.	Mid- Lv.	Mid- Slab	Corner App.	Mid- Lv.	Mid- Slab	t	Corner App.	Mid- Lv.	Mid- Slab	Corner App.	Mid- Lv.	Mid- Slab
20-Foot Slabs														
5 in. O. T.	4	15	16	12	27	26	29	3	29	25	-	27	23	-
5 in. D. G.	4	18	16	25	33	30	41	3	11	18	20	34	26	31
5 in. S. C.	-2	54	34	23	41	39	31	4	24	28	-	25	29	-
7% C. M.	0	26	26	21	28	28	36	6	22	24	-	29	28	-
N. S.	0	31	30	22	41	40	36	3	36	48	-	31	33	-
100-Foot Slabs														
5 in. O. T.	11	13	11	16	28	37	38	2	23	26	15	27	26	31
5 in. D. G.	6	14	16	12	32	32	31	0	21	31	12	29	27	25
5 in. S. C.	8	22	24	21	35	34	38	6	23	28	23	30	29	28
7% C. M.	15	36	26	23	33	31	39	6	20	22	14	32	30	-
N. S.	9	61	60	15	33	47	39	8	57	75	27	38	40	39

t = Temperature of top of slab minus temperature at bottom of slab.

when a truck wheel was at the gage position. The larger of these two values was listed in Table 8. For this reason the tabulated corner strains do not differ greatly from those at mid slab.

Visual Observations of Pavement

Thus far, four condition surveys to observe the amount of joint pumping, edge pumping and edge blowing have been made by the Ohio Department of Highways. Previous surveys have led to the conclusion that curbs, acceleration and deceleration lanes materially reduce the surface evidence of pumping and edge blowing and that joint spacing has a material effect also. Therefore, in the composite summary of these surveys, the figures are based on 100 feet of uncurbed length and the different joint spacings are shown separately.

These surveys show that the opened-textured granular subbases have the least visual evidence of pumping and blowing. Next in rank are the dense-graded and last are the no-subbase sections. The soil-cement and cement-modified subbases are definitely better than the no-subbase sections.

By April 1954, the faulting and cracking of one of the no-subbase subsections with 100-foot joint spacing had become so severe that corrective maintenance was required. The other no-subbase subsections had by this time shown definite indications of some loss of subgrade support. All of the no-subbase subsections were undersealed with bituminous material on April 21, 1954.

A featured crushed limestone granular shoulder, about 3 inches thick at the pavement's edge and about 3 feet wide, was placed along the outside pavement edge for the entire length of the test road in August 1954, to correct the dangerous shoulder condition of some of the subsections which was due largely to severe pumping and edge blowing action.

TENTATIVE CONCLUSIONS

As previously stated, it is still too early to draw definite conclusions as to the relative merits of each subbase treatment. All treatments perform better than untreated subgrade. This is especially noticeable under the 100-foot slabs, where several failures have occurred on the subsections on the untreated subgrade and considerable maintenance has been required.

References

1. Proceedings, Highway Research Board, Vol. 22, p. 281 (1948).
2. American Geophysical Union Transactions, Vol. 27, No. 6, Dec. 1946.
3. Soil Service, Vol. 67, No. 6, June 1949.

Appendix

TABLE A
CHARACTERISTICS OF UPPER ONE FOOT OF SUBGRADE
(Field Density Tests Represent Top Six Inches Only)

Type of Subbase	Station Limits	Sieve Analysis, % Passing #10 #200		Based on Laboratory Tests of Samples of Delivered Material										Based on Field Density Tests				
				Particle Size, %				Plasticity Constants		HRB ^a Soil Classification	Moist Den Test		Opt Moist, % ^b	Comp Moist %	Max Lab. Dry Wt., pcf ^b	Comp Dry Wt., pcf	Percent Comp	
				Coarse Sand	Fine Sand	Silt	Clay	Liquid Limit	Plast Index		Max Dry Wt., pcf	Opt Moist %						
3 in O T	1045-1050	99	91	3	5	51	40	35	17	A-6(11)	109 4	16 7	14 6	8 8	114 5	116 1	101 3	
5 in C T	1050-1055	95	84	6	5	52	32	34	15	A-6(10)	109 6	16 9	16 4	11 6	110 8	114 0	102 9	
8 in O T	1055-1060	95	84	6	5	47	37	35	17	A-6(11)	108 1	16 7	16 2	10 9	111 3	113.1	101 6	
3 in D G	1060-1065	98	89	4	5	53	36	37	17	A-6(11)	108 9	16 9	16 5	12 5	110 4	115 1	104 2	
5 in. D G	1065-1070	100	90	5	5	55	33	36	16	A-6(10)	103 0	20 3	16 9	14 2	109 6	112 8	102 9	
8 in D G	1070-1075	97	80	8	9	46	34	35	14	A-6(10)	111 5	16 4	14 9	12 3	114 1	116 0	101 7	
3 in S C	1075-1080	99	92	3	4	47	43	38	19	A-6(12)	110 0	15 6	14 6	12 7	114.6	115 3	100 6	
5 in S C	1080-1085	95	85	6	4	46	39	40	18	A-6(11)	105 2	16 4	15 2	9 3	113.3	117 1	103 4	
11% C M	1085-1090	96	83	7	6	43	40	38	18	A-6(11)	107 1	18 6	14 6	11 5	114 6	115 2	101 0	
5% C M	1090-1095	98	83	8	7	38	45	33	14	A-6(10)	107 8	18 0	12 1	11 2	122 0	125 3	102 7	
7% C M	1095-1100	99	82	9	8	52	30	36	16	A-6(10)	104 6	20 0	12 0	8 3	121 8	125 3	102 9	
9% C M	1100-1105	99	90	5	4	51	39	37	18	A-6(11)	109 4	17 6	15 1	12 7	115 5	117 0	101 3	
N S	1105-1110	97	86	5	6	45	41	35	16	A-6(10)	110 5	16 9	13 6	9 3	117 5	116 8	99 4	
3 in O T	1115-1120	96	76	11	9	39	37	31	14	A-6(10)	113 7	15 6	16 0	10 3	113 2	116 3	102 7	
5 in O T	1120-1125	97	78	7	12	38	40	34	17	A-6(11)	113 2	15 7	13 8	9 2	117 8	120 5	102 2	
8 in O T	1125-1130	95	88	9	18	39	29	32	14	A-6(8)	115 1	14 6	13 5	8 0	117 0	117 8	100 6	
3 in D G	1130-1135	98	81	7	10	44	37	37	19	A-6(12)	110 9	15 8	15 4	9 5	112 9	114 4	101 3	
5 in D G	1135-1140	96	77	9	10	39	38	32	16	A-6(10)	112 6	15 9	16 1	10 8	111 4	116 6	104 7	
8 in D G	1140-1145	98	75	10	13	43	32	30	13	A-6(9)	112 3	15 5	15 1	10 9	113 8	117 9	103 6	
3 in S C	1145-1150	97	72	11	14	42	30	30	12	A-6(8)	111 9	15 1	15 5	9 8	112 8	110 8	98 2	
5 in S C	1150-1155	94	75	9	10	46	29	35	15	A-6(10)	108 1	16 8	16 9	11 0	109 6	106 6	97 2	
11% C M	1155-1160	96	80	6	10	47	33	33	15	A-6(10)	108 9	16 7	15 8	10 6	112 0	107 9	96 4	
5% C M	1160-1165	97	78	8	11	44	34	37	17	A-6(11)	110 1	16 4	16 9	11 2	109 8	110 1	100 5	
7% C M	1165-1170	99	85	6	8	49	36	38	17	A-6(11)	108 9	17 6	18 8	16 1	105 5	107 7	102 1	
9% C M	1170-1175	99	85	6	8	52	33	36	15	A-6(10)	106 5	18 3	18 6	14 0	105 9	110 9	104 7	
N S	1175-1180	97	82	8	7	45	37	40	18	A-6(11)	107 9	16 8	17 8	13 4	107 9	106 9	99 1	
3 in S C	1180-1185	94	76	10	8	47	29	37	16	A-6(10)	-	-	16 6	11 8	110 4	108 9	98 7	
5 in S C	1185-1190	90	74	8	8	43	31	39	18	A-6(11)	-	-	18 0	15 8	107 2	108 9	99 8	
11% C M	1190-1195	93	85	10	18	34	31	36	18	A-6(8)	-	-	14 6	16 6	114 6	105 0	91 7	
5% C M	1195-1200	97	74	9	14	36	38	42	22	A-7-6(13)	-	-	18 1	15 0	107 1	107 9	105 7	
7% C M	1200-1205	98	79	8	11	37	42	31	14	A-6(10)	-	-	14 1	11 6	114.5	116 3	101 6	
9% C M	1205-1210	97	76	11	10	34	42	38	18	A-6(11)	-	-	-	-	-	-	-	
8 in O T	1210-1215	94	70	12	12	36	34	34	15	A-6(9)	112 1	15 6	15 8	12 8	112 1	114 0	101 7	
3 in O T	1215-1220	94	69	13	12	31	38	34	16	A-6(9)	105 1	17 9	15 6	10 4	112 6	109 9	97 6	
3 in O T	1220-1225	92	69	12	11	36	33	36	17	A-6(10)	109 5	16 2	16 2	14 8	111 2	111 5	100 3	
8 in D G	1225-1230	94	70	11	13	37	33	39	19	A-6(10)	106 1	17 8	13 0	8 1	118.5	113 8	96 1	
5 in D G	1230-1235	96	73	11	12	39	34	35	15	A-6(10)	109 3	15 8	-	-	-	-	-	
3 in D G	1235-1240	91	66	12	13	31	35	32	15	A-6(8)	118 2	14 0	10 5	6 5	126 6	119 3	94 5	
N S	1240-1245	94	69	12	13	36	33	31	14	A-6(9)	115 4	14 6	14 7	9 4	114 5	112 4	98 2	
3 in D G	1245-1250	95	69	12	14	34	35	33	16	A-6(9)	109 7	16 2	-	-	-	-	-	
5 in D G	1250-1255	98	70	11	17	36	34	36	18	A-6(10)	109 5	18 4	12 7	8 3	119 3	120 9	101 3	
8 in D G	1255-1260	94	69	12	13	33	36	35	18	A-6(10)	112 8	14 7	12 7	8 2	119 3	122 2	102 2	
8 in O T	1260-1265	98	80	9	9	37	43	42	21	A-7-6(13)	-	-	18 1	17 1	107 1	107 1	100 0	
5 in O T	1265-1270	90	65	13	12	32	38	36	18	A-6(9)	109 5	15 3	13 5	9 6	117 0	107 7	92 7	
3 in O T	1270-1275	89	63	14	12	33	30	36	17	A-6(9)	112 0	15 5	12 7	8 2	119 3	112 6	94 4	
3 in S C	1275-1280	94	68	13	13	34	34	38	17	A-6(10)	112 6	14 5	14 6	11 4	114 6	119 6	104 4	
5 in S C	1280-1285	92	73	9	10	39	34	33	15	A-6(10)	109 6	15 8	15 8	11 9	112 0	113 4	101 3	
5% C M	1285-1290	90	67	11	12	36	31	34	15	A-6(9)	110 9	15 3	-	-	-	-	-	
7% C M	1290-1295	91	68	11	12	32	36	35	16	A-6(9)	110 1	16 2	14 6	10 6	114 6	115 9	101 1	
9% C M	1295-1300	92	73	10	9	33	40	33	15	A-6(10)	111 4	15 5	-	-	-	-	-	
N.S	1300-1305	93	72	11	10	34	38	32	15	A-6(9)	112 5	15 2	-	-	-	-	-	
Avg of	1115-1160	97	78	8	11	44	34	34	16	A-6(10)	110 8	16 2	16 1	11 1	111 5	112 6	101 1	
Avg of	1180-1245	94	72	10	12	37	35	36	17	A-6(10)	110 8	16 0	15 3	12 1	113 6	111 4	98 3	
Avg of	1045-1305	95	76	9	10	41	36	35	16	A-6(10)	110 0	16 4	15 2	11 3	113 6	114 0	100 4	

^a"Classification of Highway Subgrade Material" as adopted by the Highway Research Board in 1945
^bData from typical moisture density curves

TABLE B
CHARACTERISTICS OF GRANULAR SUBBASES

Comp. Thickness in.	Station Limits	Based on Laboratory Tests of Samples of Delivered Material											Based on Field Density Tests							
		Sieve Analysis % Passing						Particle Size, %		Plasticity Constants		HRB ^a Soil Classification	Permeability Coeff. ft./day	Moist. Den. Test		Opt. Moist. % ^b	Comp. Moist. %	Max. Lab. Dry Wt. pcf. ^b	Comp. Dry Wt. pcf.	Per-cent Comp.
		1 1/4"	1"	3/4"	4	40	200	Coarse Sand	Fine Sand	Liquid Limit	Plast Index			Max. Lab. Dry Wt. pcf.	Opt. Moist. %					
		Open Textured																		
3	1045-1050	100	100	34	9	6	5	2	17	N. P.	A-1a(0)	279	123.2	13.8	10.1	6.5	126.9	132.4	104.4	
3	1115-1120	100	100	45	13	9	8	3	-	N. P.	A-1a(0)	224	-	-	10.2	4.8	126.8	126.3	99.8	
3	1220-1225	100	100	38	10	7	5	3	19	1	A-1a(0)	910	126.8	11.0	11.5	8.1	126.8	127.0	100.1	
3	1270-1275	100	100	36	9	7	5	2	-	N. P.	A-1a(0)	768	122.1	12.7	10.2	4.8	126.8	125.0	98.7	
5	1050-1055	100	100	37	11	8	7	2	18	1	A-1a(0)	500	124.8	12.0	10.1	4.9	126.9	126.5	99.8	
5	1120-1125	100	100	43	10	8	7	2	-	N. P.	A-1a(0)	538	-	-	10.6	6.0	126.8	121.1	95.7	
5	1215-1220	100	100	41	12	8	11	3	20	2	A-1a(0)	967	129.0	11.6	10.2	6.5	126.8	121.0	95.2	
5	1265-1270	100	100	32	12	9	4	2	-	N. P.	A-1a(0)	533	128.1	11.1	10.2	4.8	126.8	122.9	97.0	
8	1055-1060	100	100	43	13	7	8	2	16	N. P.	A-1a(0)	393	125.2	13.3	10.1	5.7	126.9	129.8	102.4	
8	1125-1130	100	100	42	12	8	7	3	20	2	A-1a(0)	513	125.0	10.4	10.2	5.9	126.8	126.3	99.6	
8	1210-1215	100	100	37	11	6	6	4	19	2	A-1a(0)	681	128.5	10.8	10.2	6.2	126.8	125.2	98.9	
8	1260-1265	100	100	26	8	6	4	2	-	N. P.	A-1a(0)	764	116.4	10.7	10.2	5.9	126.8	120.4	95.0	
Dense Graded																				
3	1060-1065		100	99	36	18	41	8	-	N. P.	A-1b(0)	0.13	127.5	11.4	12.6	3.5	127.5	126.0	98.8	
3	1130-1135		100	96	36	21	38	9	-	N. P.	A-1b(0)	0.20	128.1	11.1	11.5	2.9	128.3	126.5	98.5	
3	1235-1240		-	-	-	-	-	-	-	-	-	-	-	-	11.5	4.2	128.3	126.5	98.6	
3	1245-1250		100	99	38	26	43	7	-	N. P.	A-2-4(0)	0.08	127.4	10.8	11.5	5.0	128.3	127.5	99.4	
5	1065-1070		100	100	36	25	39	6	-	N. P.	A-1b(0)	0.02	128.3	10.8	12.6	3.9	127.5	126.1	98.9	
5	1135-1140		100	99	43	27	39	9	-	N. P.	A-2-4(0)	0.10	128.0	10.6	11.5	4.1	128.3	120.5	93.7	
5	1230-1235		100	99	35	21	42	8	-	N. P.	A-1b(0)	0.04	127.1	11.1	11.5	6.3	128.3	123.1	96.0	
5	1250-1255		100	100	42	27	40	8	-	N. P.	A-2-4(0)	0.14	130.0	11.0	11.5	8.4	128.3	124.2	96.8	
8	1070-1075		100	99	24	17	39	4	-	N. P.	A-1b(0)	1.02	127.6	11.7	12.6	3.9	127.5	126.2	99.0	
8	1140-1145		100	98	36	22	42	7	-	N. P.	A-1b(0)	0.10	128.3	10.7	11.5	3.5	128.3	122.6	95.7	
8	1225-1230		100	98	26	17	39	5	-	N. P.	A-1b(0)	0.03	126.7	11.3	11.5	6.2	128.3	126.7	98.8	
8	1255-1260		100	99	40	25	41	9	-	N. P.	A-1b(0)	0.45	127.9	10.7	11.5	9.0	128.3	126.4	98.5	

^a "Classification of Highway Subgrade Material" as adopted by the Highway Research Board in 1945.

^b Actual laboratory tests representative of the material in place.

TABLE C
CHARACTERISTICS OF CEMENT TREATED SUBBASES

Comp. Thickness, in.	Station Limits	Sieve Analysis, % Ret. on #10	Particle Size %				Plasticity Constants		HRB ^c Soil Classification	Max. Lab. Dry Wt. (Incl. Cem.) pcf.	Max. Lab. Wet Wt. (Incl. Cem.) pcf.	Wet Wt. as Placed pcf.	Opt. Moist. %	Moist. as Placed, %	Cem. Cont., %	Remarks
			Coarse Sand	Fine Sand	Silt	Clay	Liquid Limit	Plast. Index								
Soil Cement																
3	1075-1080	5	8	7	35	45	31	14	A-6(10)	104.4	126.4	125.3	19.5	21.3	14.1	
3	1145-1150	5	8	7	35	45	31	14	A-6(10)	104.6	125.8	123.6	20.2	18.4	(1)	(1)1145+00 to 1147+50 -20.5% ^a
3	1180-1185	5	8	7	35	45	31	14	A-6(10)	105.3	125.8	124.5	19.5	19.1	14.4	1147+50 to
3	1275-1280	5	8	7	35	45	31	14	A-6(10)	109.3	128.3	125.5	16.0	19.3	14.4	1150+00 -20.9% ^a
5	1080-1085	5	8	7	35	45	31	14	A-6(10)	105.5	125.5	123.0	18.0	21.5	(2)	(2)1080+00 to 1082+50 -14.1%
5	1150-1155	5	8	7	35	45	31	14	A-6(10)	103.1	124.4	124.9	21.1	20.0	(3)	1082+50 to 1085+00 -14.2%
5	1185-1190	5	8	7	35	45	31	14	A-6(10)	105.7	126.2	125.2	19.0	18.7	14.2	(3)1150+00 to 1152+50 -20.7% ^b
5	1280-1285	5	8	7	35	45	31	14	A-6(10)	108.8	128.4	127.6	17.5	17.9	14.1	1152+50 to 1155+00 -18.9% ^b
Cement Modified																
6	1085-1090	5	8	7	35	45	31	14	A-6(10)	105.8	126.9	123.4	18.5	20.2	(4)	(4)1085+00 to 1087+50 -11.0%
6	1155-1160	5	8	7	35	45	31	14	A-6(10)	105.6	127.4	126.2	20.4	20.7	11.0	1087+50 to 1090+00 -10.0%
6	1190-1195	5	8	7	35	45	31	14	A-6(10)	104.7	126.8	123.6	20.0	18.3	(5)	(5)1190+00 to 1192+50 -11.8%
6	1090-1095	5	8	7	35	45	31	14	A-6(10)	108.3	128.4	125.7	15.5	18.3	5.2	1192+50 to 1195+00 -11.0%
6	1160-1165	5	8	7	35	45	31	14	A-6(10)	105.1	125.8	123.4	19.5	18.8	(6)	(6)1160+00 to 1162+50 -6.3%
6	1195-1200	5	8	7	35	45	31	14	A-6(10)	105.8	125.7	122.7	18.3	19.8	5.0	1162+50 to 1165+00 -5.0%
6	1285-1290	5	8	7	35	45	31	14	A-6(10)	106.9	126.2	128.2	17.1	18.6	5.0	1165+00 -5.0%
6	1095-1100	5	8	7	35	45	31	14	A-6(10)	107.8	128.8	126.7	19.2	20.6	7.2	
6	1165-1170	5	8	7	35	45	31	14	A-6(10)	104.7	124.9	123.2	18.9	17.0	7.0	
6	1200-1205	5	8	7	35	45	31	14	A-6(10)	105.1	126.2	124.2	18.4	18.8	7.0	
6	1290-1295	5	8	7	35	45	31	14	A-6(10)	106.7	127.0	127.2	18.0	18.5	(7)	(7)1290+00 to 1292+50 -6.7%
6	1100-1105	5	8	7	35	45	31	14	A-6(10)	107.5	128.5	127.0	18.6	19.2	9.0	1292+50 to
6	1170-1175	5	8	7	35	45	31	14	A-6(10)	103.7	124.9	122.6	19.3	19.7	8.3	1295+00 -7.2%
6	1295-1300	5	8	7	35	45	31	14	A-6(10)	109.7	130.2	129.5	18.2	18.4	9.0	

^a Includes 6.1% additional cement added when section was reworked.

^b Includes 4.9% additional cement added when section was reworked.

^c "Classification of Highway Subgrade Material" as adopted by the Highway Research Board in 1945.

TABLE D
1953 24-HOUR WEEKDAY TRAFFIC COUNT

Month	Light Vehicles		Heavy Vehicles		Total Heavy Vehicles	Total Vehicles
	Pass. Cars	Panels & Pickups	Single Unit Trucks	Combination Trucks		
January	2637	217	325	2309	2634	5488
February ^a	2360	178	237	2020	2257	4795
March	2306	163	189	1994	2183	4652
April	3121	290	344	2022	2366	5777
May	3137	247	295	2253	2548	5932
June	3920	267	406	1955	2361	6548
July	4696	227	372	1818	2190	7113
August	4993	291	340	2215	2555	7839
September	3879	252	278	1937	2215	6346
October	3122	245	366	1843	2209	5576
November	2888	192	269	1728	1997	5077
December	2644	180	241	1753	1994	4818
Av. Yearly Weekday	3309	229	305	1987	2292	5830

^a Estimated

TABLE E
1954 24-HOUR WEEKDAY TRAFFIC COUNT

Month	Light Vehicles		Heavy Vehicles		Total Heavy Vehicles	Total Vehicles
	Pass. Cars	Panels & Pickups	Single Unit Trucks	Combination Trucks		
January	2176	159	203	1794	1997	4332
February	2439	183	207	1844	2051	4673
March	2898	215	293	1873	2166	5279
April ^a	3307	217	272	1744	2016	5540
May	3715	219	251	1615	1866	5800
June ^a	4381	215	260	1577	1837	6433
July	5048	210	269	1538	1807	7065
August	4765	250	259	1485	1744	6759
September ^a	4139	234	262	1573	1835	6208
October ^a	3514	219	264	1661	1925	5658
November	2889	204	266	1748	2014	5107
December	2577	218	269	2107	2376	5171
Av. Yearly Weekday	3487	212	256	1713	1969	5668

^a Estimated

TABLE F
TANDEM TRUCK AXLE FREQUENCY BY VARIOUS WEIGHT GROUPS FOR A 24-HOUR WEEKDAY

Axle Weight Groups, Thousands of Pounds	Number of Tandem Axles, Listed Individually															
	1953										1954					
	Jan.	Apr.	May	June	July	Aug.	Sept.	Oct.	Nov.	Dec.	Jan.	Feb.	Mar.	May	July	Aug.
No Pay Load	858	718	754	752	626	860	708	558	498	646	538	544	598	438	564	550
Under 14	652	979	1095	936	1006	1049	981	724	921	985	1082	1120	1083	993	864	903
14 to 15	179	87	156	117	155	173	160	96	72	123	166	86	143	113	116	119
15 to 16	184	72	60	68	88	68	95	67	42	74	46	46	75	43	54	70
16 to 17	94	26	20	26	44	53	35	32	14	12	46	11	18	29	22	18
17 to 18	37	6	7	9	18	19	15	16	11	-	-	3	23	12	10	10
18 to 19	14	-	-	7	5	6	9	4	3	6	-	3	9	2	6	2
19 to 20	8	-	-	2	-	2	6	1	3	6	-	-	5	-	8	2
20 to 21	-	-	-	2	-	-	1	-	-	-	-	3	-	-	-	4
21 to 22	-	-	-	-	-	-	4	-	-	-	-	-	-	-	-	2
22 to 23	-	-	-	-	-	-	-	-	-	-	-	-	-	-	-	-
23 to 24	-	-	-	-	-	-	-	-	-	-	-	-	-	-	-	-
24 & Over	-	-	-	-	-	-	-	-	-	-	-	-	-	-	-	-
Total	2026	1888	2092	1918	1942	2230	2014	1498	1564	1852	1878	1816	1954	1630	1644	1680

TABLE G
SINGLE TRUCK AXLE FREQUENCY BY VARIOUS WEIGHT GROUPS FOR A 24-HOUR WEEKDAY

Axle Weight Groups Thousands of Pounds	Number of Single Axles															
	1953										1954					
	Jan.	Apr.	May	June	July	Aug.	Sept.	Oct.	Nov.	Dec.	Jan.	Feb.	Mar.	May	July	Aug.
No Pay Load	2815	2932	3240	2764	2454	3022	2633	2695	2262	1886	2304	2104	2171	1672	1986	1831
Under 14	2855	2284	2465	2154	2014	2128	1899	2020	1904	2055	2132	2008	2173	1939	1545	1577
14 to 15	379	330	336	388	332	446	329	328	298	379	333	408	336	327	266	222
15 to 16	396	242	329	277	311	381	284	267	306	324	333	335	329	300	266	218
16 to 17	260	254	286	233	239	243	244	263	219	168	308	240	224	225	206	180
17 to 18	272	204	277	257	233	288	208	201	197	193	245	209	203	227	184	176
18 to 19	177	154	165	155	144	203	181	174	184	122	164	156	149	144	142	127
19 to 20	88	50	67	100	67	77	134	67	98	46	125	89	86	73	78	53
20 to 21	74	22	20	31	20	32	30	36	16	19	25	36	28	16	20	25
21 to 22	3	6	-	16	9	2	8	6	9	-	5	5	7	3	4	-
22 to 23	3	-	2	3	5	4	3	3	1	-	-	-	2	1	2	-
23 to 24	-	-	-	-	-	-	1	-	-	-	5	-	-	-	-	-
24 & Over	-	3	2	-	2	-	-	-	-	6	-	-	-	-	-	-
Total	7322	6481	7189	6378	5830	6826	5954	6060	5584	5198	5979	5590	5708	4927	4699	4409

TABLE H
TOTAL TRUCK AXLE FREQUENCY BY VARIOUS WEIGHT GROUPS FOR A 24-HOUR WEEKDAY

Axle Weight Groups Thousands of Pounds	Total Number of Axles															
	1953										1954					
	Jan.	Apr.	May	June	July	Aug.	Sept.	Oct.	Nov.	Dec.	Jan.	Feb.	Mar.	May	July	Aug.
No Pay Load	3673	3650	3994	3516	3080	3882	3341	3253	2760	2532	2842	2648	2769	2110	2550	2381
Under 14	3507	3263	3560	3090	3020	3177	2880	2744	2915	3040	3214	3128	3256	2932	2409	2480
14 to 15	558	417	492	505	487	619	489	424	370	502	499	494	479	440	382	341
15 to 16	580	314	389	344	399	449	379	334	348	398	379	381	404	343	320	288
16 to 17	354	280	308	259	283	296	279	295	233	180	354	251	242	254	228	198
17 to 18	309	210	284	266	251	307	223	217	208	193	245	212	226	239	194	186
18 to 19	191	154	165	162	149	209	190	178	187	128	164	159	158	146	148	129
19 to 20	96	50	67	102	67	79	140	68	101	52	125	89	91	73	86	55
20 to 21	74	22	20	33	20	32	31	36	16	19	25	39	28	16	20	29
21 to 22	3	6	-	16	9	2	12	6	9	-	5	5	7	3	4	2
22 to 23	3	-	2	3	5	4	3	3	1	-	-	-	2	1	2	-
23 to 24	-	-	-	-	-	-	1	-	-	-	5	-	-	-	-	-
24 & Over	-	3	2	-	2	-	-	-	-	6	-	-	-	-	-	-
Total	9348	8369	9281	8296	7772	9056	7968	7558	7148	7050	7857	7406	7662	6557	6343	6089

TABLE I
EXPERIMENTAL SUBBASE PROJECT, FIELD SURVEYS TO DATE^a
 Summary of Pumping per 100 Foot of Uncurbed Length Itemized by Specific Subbase Type and Slab Length

Type of Subbase	Number of Pumping Joints								Number of Pumping Edges							
	20-Foot Slabs				100-Foot Slabs				20-Foot Slabs				100-Foot Slabs			
	1st.	2nd.	3rd.	4th.	1st.	2nd.	3rd.	4th.	1st.	2nd.	3rd.	4th.	1st.	2nd.	3rd.	4th.
3 in. Open Textured	-	-	-	-	-	-	-	-	-	0.1	-	-	-	-	-	-
5 in. Open Textured	-	-	-	-	-	-	-	-	-	-	-	-	-	-	-	-
8 in. Open Textured	-	-	-	-	-	-	-	-	-	-	-	-	-	-	-	-
3 in. Dense Graded	-	-	-	-	-	-	-	-	-	0.9	0.4	-	-	-	-	-
5 in. Dense Graded	-	-	-	-	-	-	-	-	-	-	-	-	-	-	-	-
8 in. Dense Graded	-	0.1	0.2	0.1	-	-	-	-	-	0.4	0.1	-	-	-	-	-
3 in. Soil Cement	-	-	0.9	1.0	-	0.6	1.1	0.8	-	1.4	2.7	0.2	-	1.1	0.8	-
5 in. Soil Cement	-	-	0.7	-	-	0.2	0.4	0.2	-	1.0	2.5	-	0.1	0.4	0.4	-
6 in. Cement Modified, 5%	-	0.6	4.2	1.8	-	0.5	0.5	0.5	0.3	3.4	3.5	0.1	-	1.0	0.9	0.9
6 in. Cement Modified, 7%	-	0.6	2.5	2.2	-	-	0.7	0.3	0.5	5.1	2.6	1.3	-	1.7	2.4	0.9
6 in. Cement Modified, 9%	0.1	0.3	1.7	1.0	-	-	0.2	0.2	0.4	3.5	1.2	2.1	-	0.5	1.4	0.2
6 in. Cement Modified, 11%	-	0.8	1.6	1.0	-	0.2	0.7	0.7	0.2	1.6	1.0	0.2	-	0.6	0.7	-
No Subbase ^b	0.7	1.3	7.0	4.7	0.1	0.1	0.7	0.2	-	1.7	3.4	1.0	0.1	0.9	1.4	0.1

Summary of Blowing per 100 Foot of Uncurbed Length Itemized by Specific Subbase Type and Slab Length

Type of Subbase	Number of Blowholes								Feet of Continuous Blowing							
	20-Foot Slabs				100-Foot Slabs				20-Foot Slabs				100-Foot Slabs			
	1st.	2nd.	3rd.	4th.	1st.	2nd.	3rd.	4th.	1st.	2nd.	3rd.	4th.	1st.	2nd.	3rd.	4th.
3 in. Open Textured	0.1	0.3	4.6	0.2	-	-	0.2	-	-	-	-	-	-	-	-	-
5 in. Open Textured	0.2	1.7	2.4	-	-	-	2.2	-	-	-	-	-	-	-	-	-
8 in. Open Textured	0.3	1.1	0.1	-	-	-	1.6	-	-	-	-	-	-	-	-	-
3 in. Dense Graded	-	6.8	11.9	0.3	-	0.8	10.2	0.1	-	1.0	-	-	-	1.2	-	-
5 in. Dense Graded	0.4	11.5	18.9	-	-	-	12.6	0.1	-	1.7	-	-	-	-	-	-
8 in. Dense Graded	1.1	13.3	17.8	-	-	3.0	18.4	-	-	4.4	3.2	-	-	-	-	-
3 in. Soil Cement	1.3	16.3	27.8	0.1	0.6	2.2	12.3	2.8	-	1.8	-	-	-	11.0	2.2	-
5 in. Soil Cement	0.8	20.6	12.1	-	0.9	2.9	3.4	0.2	-	8.3	11.5	-	-	2.5	0.6	-
6 in. Cement Modified, 5%	2.0	14.2	5.6	1.1	0.3	2.9	4.6	0.8	-	6.1	2.1	-	-	5.1	1.1	-
6 in. Cement Modified, 7%	9.1	10.0	12.8	2.1	1.5	9.8	2.1	1.9	1.1	17.0	19.9	-	-	1.3	2.5	-
6 in. Cement Modified, 9%	10.9	22.6	25.4	1.8	0.6	14.2	0.9	1.0	0.3	24.9	8.4	-	-	1.2	0.8	-
6 in. Cement Modified, 11%	2.8	13.2	13.0	-	4.1	9.6	8.0	0.8	-	-	5.0	-	-	6.7	1.0	-
No Subbase ^b	4.4	19.5	3.4	-	0.1	1.7	1.6	-	-	-	8.7	-	-	-	1.3	-

^a 1st., 2nd., 3rd. and 4th. refer to the field surveys of March 26, 1953, May 14, 1953, March 15, 1954 and December 10, 1954 respectively.

^b All of the no-subbase sections were subsealed with bituminous material on April 21, 1954.

Note: On August 20 and 23, 1954, a feathered granular shoulder, about 3 inches thick at the pavement's edge and about 3 feet wide, was placed the full length of the project to correct the low shoulder condition.

TABLE J
EXPERIMENTAL SUBBASE PROJECT, FIELD SURVEYS TO DATE^a
Summary of Pumping per 100 Foot of Uncurbed Length Itemized by General Subbase Type and Slab Length

Type of Subbase	Number of Pumping Joints								Number of Pumping Edges							
	20-Foot Slabs				100-Foot Slabs				20-Foot Slabs				100-Foot Slabs			
	1st.	2nd.	3rd.	4th.	1st.	2nd.	3rd.	4th.	1st.	2nd.	3rd.	4th.	1st.	2nd.	3rd.	4th.
Open Textured	-	-	-	-	-	-	-	-	-	-	-	-	-	-	-	-
Dense Graded	-	-	0.1	-	-	-	-	-	-	0.4	0.2	-	-	-	-	-
Soil Cement	-	-	0.8	0.5	-	0.4	0.7	0.5	-	2.7	2.6	0.1	-	0.7	0.6	-
Cement Modified	-	0.6	2.5	1.5	-	0.2	0.5	0.4	0.4	3.4	2.1	0.9	-	0.9	1.3	0.5
No Subbase ^b	0.7	1.3	7.0	4.7	0.1	0.1	0.7	0.2	-	1.7	3.4	1.0	0.1	0.9	1.4	0.1

Summary of Blowing per 100 Foot of Uncurbed Length Itemized by General Subbase Type and Slab Length

Type of Subbase	Number of Blowholes								Feet of Continuous Blowing							
	20-Foot Slabs				100-Foot Slabs				20-Foot Slabs				100-Foot Slabs			
	1st.	2nd.	3rd.	4th.	1st.	2nd.	3rd.	4th.	1st.	2nd.	3rd.	4th.	1st.	2nd.	3rd.	4th.
Open Textured	0.2	1.0	2.4	0.1	-	-	1.3	-	-	-	-	-	-	-	-	-
Dense Graded	0.5	10.5	16.4	0.1	-	1.3	13.7	0.1	-	2.4	1.1	-	-	0.4	-	-
Soil Cement	1.2	18.5	20.0	0.1	0.7	2.6	7.8	1.5	-	5.0	5.8	-	-	6.7	1.4	-
Cement Modified	6.2	15.0	14.2	1.2	1.6	9.0	3.9	1.1	0.3	12.0	8.9	-	-	3.6	1.3	-
No Subbase ^b	4.4	19.5	3.4	-	0.1	1.7	1.6	-	-	-	8.7	-	-	-	1.3	-

Summary of Pumping and Blowing per 100 Feet of Uncurbed Length Itemized by General Subbase Type

Type of Subbase	Pumping								Blowing							
	Number of Joints				Number of Edges				Number of Blowholes				Feet of Continuous			
	1st.	2nd.	3rd.	4th.	1st.	2nd.	3rd.	4th.	1st.	2nd.	3rd.	4th.	1st.	2nd.	3rd.	4th.
Open Textured	-	-	-	-	-	-	-	-	0.1	0.5	1.8	-	-	-	-	-
Dense Graded	-	-	-	-	-	0.2	0.1	-	0.3	6.9	14.9	0.1	-	1.4	0.6	-
Soil Cement	-	0.2	0.7	0.5	-	1.7	1.6	0.1	0.9	10.5	13.9	0.5	-	5.9	3.6	-
Cement Modified	-	0.4	1.5	1.3	0.2	2.2	1.7	1.0	3.9	12.0	9.1	1.6	0.1	7.8	5.1	-
No Subbase ^b	0.4	0.7	3.9	2.5	0.1	1.3	2.4	0.5	2.2	10.6	2.5	-	-	-	5.0	-

^a 1st., 2nd., 3rd. and 4th. refer to the field surveys of March 26, 1953, May 14, 1953, March 15, 1954 and December 10, 1954 respectively.

^b All of the no-subbase sections were subsealed with bituminous material on April 21, 1954.

Note: On August 20 and 23, 1954, a feathered granular shoulder, about 3 inches thick at the pavement's edge and about 3 feet wide, was placed the full length of the project to correct the low shoulder condition.

Some HRB Publications Relating to Concrete and Maintenance

Bulletin 21: MAINTENANCE COSTS (1949) 14 p. \$.15

Progress Report of the Project Committee on Maintenance Costs, J. S. Bright, Chairman; Cost of Mechanical Loaders in Ditch Cleaning as Compared with Costs of Hand Operations in Virginia, J. J. Forrer; Economics of Resurfacing Disintegrated Pavements, C. Owen Beckley.

Bulletin 29: MAINTENANCE COSTS (1950) 20 p. \$.45

Progress Report of the Project Committee on Maintenance Costs, H. A. Radzikowski, Chairman; County Road Maintenance and Operation Costs, Roger H. Willard.

Bulletin 47: SALVAGING OLD PAVEMENTS BY RESURFACING (1952) 35 p. \$.60

Bulletin 70: AIR-ENTRAINED CONCRETE: Properties of Air Voids and Service Record of Pavements (1953) 23 p. \$.60

Determination of Properties of Air Voids in Concrete, Curtis Warren; Record of Experimental Air-Entrained Concrete 10 to 14 Years After Construction, L. E. Andrews; Discussion, William Lerch.

Bulletin 75: EFFECT IN CONCRETE OF PELLET AND FLAKE FORMS OF CALCIUM CHLORIDE (1953) 18 p. \$.30

Bulletin 87: CONCRETE RESURFACING OF CONCRETE PAVEMENT IN VARIOUS STAGES OF DETERIORATION (1954) 39 p. \$.60

Bulletin 116: EXPERIMENTAL CONCRETE PAVEMENTS (1955) 71 p. \$1.35

Report on Pavement Research Project in Indiana, Walter T. Spencer, Harold Allen and Preston C. Smith; Report on Pavement Research Project in Ohio, Charles W. Allen and L. D. Childs, Appendix.

Bibliography 7: PRESTRESSING AND PRECASTING REINFORCED CONCRETE FOR USE IN HIGHWAY BRIDGES AND STRUCTURES (1949) 110 p. \$.75

Bibliography 8: DURABILITY OF CONCRETE PHYSICAL REACTIONS (1951) 35 p. \$.60

Bibliography 13: CALCIUM CHLORIDE IN CONCRETE Annotated (1952) 57 p. \$.60

Special Report 4: ROAD TEST ONE-MD (1952) 169 p. \$ 2.25

Introduction, General Summary of Project, Traffic Test Procedures and Results, Analysis of Soil Data, Analysis of Structural Effect of Heavy-Vehicle Loads, Appendix: Basic Data

Special Report 8: CONNECTICUT HIGHWAY MAINTENANCE PRODUCTION STUDY (1952) 220 p. \$2.70

Special Report 14: STRUCTURAL EFFECTS OF HEAVY-DUTY TRAILER ON CONCRETE PAVEMENT: A Supplemental Investigation to Road Test One-MD (1953) 32 p. \$.60

Current Road Problems 1-R: CURING OF CONCRETE PAVEMENTS (1952) 19 p. \$.30

Current Road Problems 3: DESIGN OF CONCRETE PAVEMENTS REQUIRING A MINIMUM OF STEEL (1942) 13 p. \$.15

Current Road Problems 4-R: MAINTENANCE METHODS FOR PREVENTING AND CORRECTING THE PUMPING ACTION OF CONCRETE PAVEMENT SLABS (1947) 30 p. \$.30

Current Road Problems 6: PATCHING CONCRETE PAVEMENTS WITH CONCRETE (1943) 16 p. \$.15

Current Road Problems 13-R: USE OF AIR-ENTRAINED CONCRETE IN PAVEMENTS AND BRIDGES (1950) 74 p. \$.45

THE NATIONAL ACADEMY OF SCIENCES—NATIONAL RESEARCH COUNCIL is a private, nonprofit organization of scientists, dedicated to the furtherance of science and to its use for the general welfare. The ACADEMY itself was established in 1863 under a congressional charter signed by President Lincoln. Empowered to provide for all activities appropriate to academies of science, it was also required by its charter to act as an adviser to the federal government in scientific matters. This provision accounts for the close ties that have always existed between the ACADEMY and the government, although the ACADEMY is not a governmental agency.

The NATIONAL RESEARCH COUNCIL was established by the ACADEMY in 1916, at the request of President Wilson, to enable scientists generally to associate their efforts with those of the limited membership of the ACADEMY in service to the nation, to society, and to science at home and abroad. Members of the NATIONAL RESEARCH COUNCIL receive their appointments from the president of the ACADEMY. They include representatives nominated by the major scientific and technical societies, representatives of the federal government designated by the President of the United States, and a number of members at large. In addition, several thousand scientists and engineers take part in the activities of the research council through membership on its various boards and committees.

Receiving funds from both public and private sources, by contribution, grant, or contract, the ACADEMY and its RESEARCH COUNCIL thus work to stimulate research and its applications, to survey the broad possibilities of science, to promote effective utilization of the scientific and technical resources of the country, to serve the government, and to further the general interests of science.

The HIGHWAY RESEARCH BOARD was organized November 11, 1920, as an agency of the Division of Engineering and Industrial Research, one of the eight functional divisions of the NATIONAL RESEARCH COUNCIL. The BOARD is a cooperative organization of the highway technologists of America operating under the auspices of the ACADEMY-COUNCIL and with the support of the several highway departments, the Bureau of Public Roads, and many other organizations interested in the development of highway transportation. The purposes of the BOARD are to encourage research and to provide a national clearinghouse and correlation service for research activities and information on highway administration and technology.
