

Performance of Doweled Joints Under Repetitive Loading

LESLIE W. TELLER, Chief, Structural Research Branch, and
HARRY D. CASHELL, Highway Physical Research Engineer,
Division of Physical Research, Bureau of Public Roads

Load-transfer systems are desirable in transverse joints of concrete pavements to control edge stresses, to reduce slab deflections under load, and to maintain surface alinement of the two slab ends.

Many forms of testing techniques have been devised to judge the performance of load-transfer systems. In most cases the tests have been performed in the laboratory and, as usually made, provide data on the shear resistance of the load-transfer unit under a single or, at most, a few static loads. Such tests, however, are rather limited in scope.

In order to develop information on the structural action of load-transfer systems under repetitive loading, the Bureau of Public Roads devised a laboratory procedure quite different from the shear test. The principle of the test is very simple. The specimen, a concrete slab divided transversely at midlength by the joint under test, is supported in a machine that applies a known load alternately on either side of the joint for any desired number of cycles. The design of the machine and the dimensions of the specimen made it possible to study, under forces and motions which simulate closely those of actual service, the effects of several variables influencing the structural performance of dowel bars.

An analysis of the data developed in the tests revealed that a definite exponential relation exists between dowel diameter and load-transfer capacity, other conditions being constant.

A relation was also evident between slab depth and the dowel diameter required to transfer a given percentage of the applied load. This relation indicated that, for minimum dowel size, the diameter in eighths of an inch should approximately equal the slab depth in inches.

For $\frac{3}{4}$ -in. diameter dowels, an embedded length of 8-dowel diameters is required for maximum load transfer. Larger dowels, such as the 1-in. and $1\frac{1}{4}$ -in. diameters now in common use, require for full-load transfer a length of embedment of about six diameters, both initially and after many hundreds of thousands of cycles of repetitive loading.

For a given load-transfer system, the tests indicated that much better structural performance could be expected in a contraction joint than in an expansion joint.

● THE USE of smooth, round steel bars for the purpose of transferring load across transverse joints in concrete pavements seems to have been first reported in connection with a pavement built in the winter of 1917-18 between two army camps near Newport News, Va. In this installation four $\frac{3}{4}$ -in. diameter bars were used in the 20-ft pavement width.

In the years that followed World War I, the use of steel dowels, as they came to be called, spread quite rapidly. During this period, the detailed requirements as to diameter, length, and spacing varied widely. For a joint across the full width of the pavement, one state in 1926 required two $\frac{1}{2}$ -in. diameter bars 4 ft long; another, four

$\frac{5}{8}$ -in. diameter bars 4 ft long; and still another, eight $\frac{3}{4}$ -in. diameter bars 2 ft long. Long bars of small diameter spaced about 30 in. apart were the general rule. By 1930 nearly half of the states required the use of dowels in transverse joints.

In 1928 Westergaard (1) published the first analysis of dowel reactions. It was based on certain assumed ideal conditions including equal deflection on both sides of the joint. He concluded that dowels 2 ft apart would bring about a material reduction in critical stress in the concrete of the pavement, but at a spacing of 3 ft they would not. No study of dowel length was made.

When the designs for the pavement sections used in the Arlington tests (2) were being developed in 1929, it was decided to include a study of doweled joints; dowel spacings of 18, 27, or 36 in. were selected for the various transverse joints. The dowels were $\frac{3}{4}$ in. in diameter and 3 ft long in all cases. These dimensions and spacings were representative of state practices at that time.

As a result of the load tests on the doweled joints in the Arlington investigation, it was concluded that none of the dowel systems tested was particularly effective in controlling critical edge stress and that dowels would have to be stiffer and much more closely spaced to be effective structurally.

The Bureau's researches into the structural action of concrete pavements stimulated a considerable amount of interest in the subject on the part of others. One result was an increased effort to develop a better understanding of the structural action of doweled joints and to rationalize their design.

In 1932, Bradbury (3) attempted to determine analytically the required diameter, length, and spacing of dowels. His studies indicated the need for larger diameter dowels at close spacing; and, through the application of the Timoshenko equations for the bending of bars on elastic foundations, he developed a formula for estimating the required length of dowels. In 1938, Friberg (4) analyzed the dowel reactions by means of the same equations and reported an experimental study of the support afforded dowels by the surrounding concrete. Friberg also emphasized the advantages to be gained from increasing dowel diameter and decreasing dowel spacing. He concluded that the length of dowels could be materially reduced below the 24 in. then in common use.

Westergaard (1), in his analytical studies of dowel reactions, had concluded that the major part of the load transfer which takes place when a wheel load approaches a transverse joint is accomplished by the 2 or, at most, 4 dowels nearest the wheel load. In 1940, Kushing and Fremont (5) published a theoretical analysis of the distribution of reactions among the several units of a doweling system, assuming elastic deflection of the dowels. As would be expected, this analysis indicated a wider distribution of reactions than was indicated by Westergaard's earlier study in which the dowels were assumed to be infinitely stiff. In discussing the Kushing and Fremont paper, Sutherland presented data from load tests on certain large slabs in the Arlington investigation. These data indicated, for the conditions of the tests with $\frac{3}{4}$ -in. diameter dowels at 18-in. spacing, the relative deflection of the two abutting slabs was largely controlled by the four units immediately adjacent to the load.

This brief review of research activity prior to about 1940 shows much progress in the effort to rationalize the structural design of doweled joints. The increased use and the cost of load-transfer systems made the problem of proper design an important one. The researches indicated the need for strong units closely spaced. It was also indicated that the long dowel bars used earlier were not necessary, and there was some optimum length for maximum effectiveness. The inherent structural deficiencies of the round steel dowel bar as a load-transfer mechanism had long been recognized and many alternate designs, frequently proprietary, were offered during this period. Some of these designs were simple structural shapes of greater stiffness; others were quite elaborate.

EARLY TEST PROCEDURES INADEQUATE

State highway departments and other agencies responsible for the selection or approval of competitive designs sought comparative data on which to base decisions.

The need for test procedures to develop such data became pressing, and many forms of testing techniques were devised to meet the need. In nearly all cases the tests were performed in the laboratory by applying a load to a relatively small specimen in such a way as to develop a shearing force, usually on one but sometimes on two or more dowels or other types of load-transfer units embedded in concrete. The load-deflection data obtained in the tests were used in various ways for judging the relative abilities of dowels and other devices in transferring load across joint openings. A typical test procedure of this type, as performed in Illinois, is described in the report of that state's investigation of joint performance (6).

Finney and Fremont (7) used a modification of this test procedure to study the effect on dowel deflection of the variables of dowel diameter, dowel length, and width of joint opening.

The laboratory shear test, as usually made, develops data on the relative shear resistance of load-transfer units under a single or, at most, a few essentially static loads. It does not, however, provide other information of equal or greater significance.

If there is any play or looseness of the dowel in its socket or, in the case of some proprietary load-transfer units, play within the unit itself, this looseness will not be revealed in the shear test even though it would have an important bearing on the structural effectiveness of the unit when the load is reversed as it is in service.

Furthermore a dowel or other load-transfer unit in the pavement is placed in action every time an axle load crosses the transverse joint—thousands, even millions of times. Each time this happens there is a complete stress reversal in the load-transfer mechanism as the load passes from one abutting slab to the other. It is well recognized that performance under a single loading is no measure of performance under repeated loading, yet as late as 1947 there existed no published data on the effects of repetitive loading and stress reversal on the structural action of dowels or other load-transfer units.

These considerations led the Bureau of Public Roads in 1947 to devise a test procedure of quite a different type, one which would provide information on the structural action of load-transfer units under repetitive loading. It was desired particularly to determine (a) the initial efficiency of such units in transferring load; (b) the degree to which this efficiency might be expected to be retained as the load cycle is repeated many thousands of times; and (c) the effect on load-transfer efficiency of such major design variables as dowel diameter, dowel length, and width of joint opening.

It is the purpose of this report to describe the test and to discuss the information that it has so far provided.

TESTING MACHINE AND SPECIMEN DESCRIBED

The principle of the test is very simple. The specimen, a concrete slab divided transversely at midlength by the joint under test, is supported in a machine that applies a known load alternately on either side of the joint for any desired number of cycles.

By means of strain and deflection measurements, made periodically, data are obtained which show the initial effectiveness of the load-transfer system and the deterioration in effectiveness which develops from repetitive application of the test load.

Testing Machine

The machine, shown in Figure 1, consists essentially of a concrete base which provides support for the specimen, a structural steel frame which furnishes a reaction for a pair of loading levers that apply the load through 10-in. diameter loading pads alternately on either side of the joint under test, dead weights at the ends of the loading levers to create the desired load, and an electrically driven cam and lift-rod mechanism which alternately raises and lowers the loading levers. The machine requires very little attention and can operate continuously.

The specimen, a concrete slab 10 ft long and 4 ft wide, is supported at its ends by fixed bearings on short pedestals that are a part of the machine base. On either side

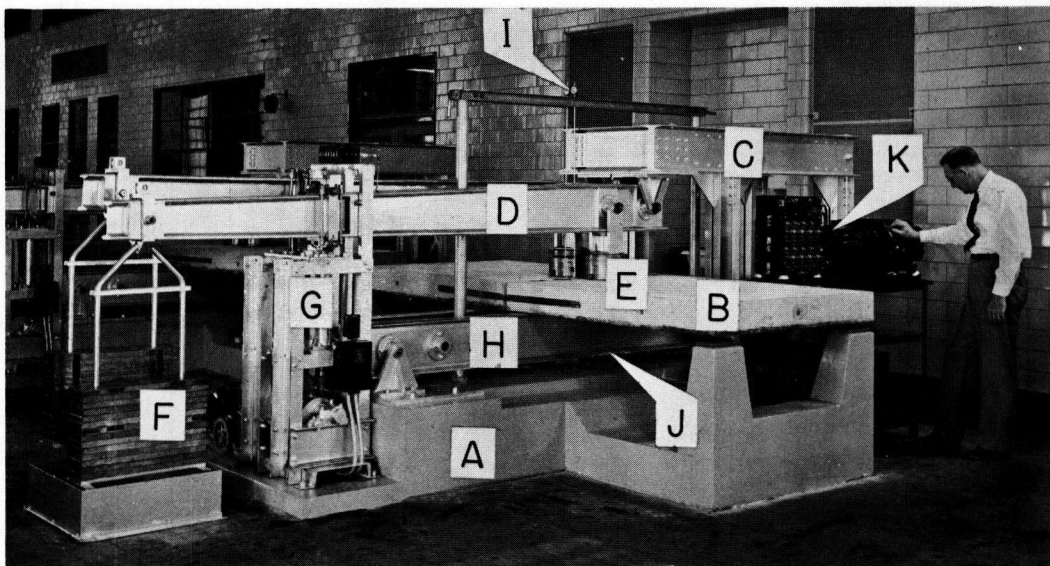

Figure 1. Testing machine (A, reinforced concrete base; B, test specimen; C, structural steel frame; D, loading lever; E, loading pad; F, adjustable load of lead weights; G, cam and lift-rod mechanism; H, specimen support beam; I, micrometer dials; J, SR-4 strain gages; and K, oscillograph recording equipment).

of the test joint each half-slab bears on a steel support beam. The deflection of the beam simulates the yielding of the subgrade when a load is applied to a pavement slab. As the load is applied on one side of the test joint by the lowering of one loading lever, the load is automatically removed from the opposite side of the joint by the lifting of the other loading lever. As this action takes place, the support beam under the loaded side deflects from the load while the support beam under the unloaded side is deflected solely by the shearing forces in the doweling system just as in the case of a pavement on the subgrade.

Two span lengths were provided for the support beams, the relation between them being such that use of the greater span length would result in deflections twice as great as would be obtained with the lesser span length, other test conditions remaining unchanged.

The dimensions of the machine are such that the deflections and the angular motion at the joint can be made to simulate closely the movements that have been measured in the load testing of full-size pavement slabs on a weak subgrade. By adjusting the length of bearing between the specimen and the support beam directly under the load, the degree of transverse curvature of the specimen and hence the stress in the concrete along the joint edge can be controlled. For the tests reported, a bearing pad having a length of 15 in. was used. With a constant load value this gives a flexural stress in the concrete along the joint edge which varies with the depth of slab being tested.

The machine is designed to apply loads rather slowly so as to avoid shock, the frequency being but 10 cycles per minute. At this rate about one week is required to obtain 100,000 complete cycles of load application and stress reversal. After the first machine was placed in operation it became apparent that even a limited program would extend over an excessively long period of time and since the test appeared to be promising three additional machines were built. Two of the four have a load capacity of 10,000 lb; the other two have a capacity of 15,000 lb. Any desired test load, up to the capacity of the machine, may be obtained by changing the number of lead weights on the platforms at the end of the loading levers.

The loading system is calibrated by placing a load-measuring device between the

pad on the loading lever and the corresponding support beam before the specimen is placed in the machine. The load-strain rate of each support beam is then developed from loads applied by the calibrated loading system and from strains as measured in the lower flanges of the beams. These rates provide a means of determining the amount of load being transferred for any given applied load. Since the unit of strain measurement is equivalent to a load increment of about 30 lb and since periodic calibrations showed negligible changes, it was concluded that determinations of the amount of load transferred were accurate within 60 lb.

In Figure 1, a pair of tubular columns supported in steel sleeves in the base and extending upward above the machine frame may be seen. They support a cross member or bridge which serves as a datum for deflection measurements. These measurements were made with micrometer dials reading directly to thousandths of an inch from which it was practicable to estimate ten-thousandths.

Test Specimen

As stated previously, the test specimen is a concrete slab 4 ft wide by 10 ft long divided transversely at midlength by the joint in which the load-transfer system is installed. So far, the slabs have been either 6, 8, or 10 in. in depth.

Since the quality of the concrete has not been a variable in the test program being reported, every effort has been made to have the strength and other properties of the concrete uniform in the specimens that have been tested. The same aggregates, grading, and proportions were used throughout. The concrete was mixed under careful control in the laboratories of the Bureau. The following summary shows average strengths and other properties of the concrete as determined by standard tests at the age of 28 days: compressive strength 5,610 psi, standard deviation 280 psi, flexural strength 770 psi, standard deviation 35 psi; and modulus of elasticity (sonic) 7, 120,000 psi.

It was particularly important that the slab specimens be precision cast and so handled that the joint installation could not be damaged before the test started. To accomplish this a concrete casting base was built. In the surface of this base were steel plate inserts to create smooth, plane, parallel surfaces on the lower surface of the specimen for the points of bearing in the testing machine. On this base the side form for the specimen was placed. This was a rectangular frame of structural steel channel of the required depth, across the center of which was fastened the steel plate partition that created the joint opening and held the load-transfer units in position and alinement. The concrete was consolidated by vibration. After the surface had been finished the specimen was covered with burlap, kept wet for 7 days, and then allowed to dry in the air of the laboratory. In general, the specimen was more than 28 days old before being subjected to load.

The dowels of the load-transfer systems were made from conventional hot-rolled, carbon steel bar stock. Tests of the material showed it to have average mechanical properties, as follows:

Tensile strength (psi)	66,533
Yield point (psi)	44,327
Percent elongation (2-in. gage length)	40.5
Modulus of elasticity (psi)	30,094,000

All dowels were so installed that their final position did not vary from true alinement by more than $\frac{1}{16}$ in. per foot of length. Just prior to concreting, the free or sliding half of each dowel was coated with heavy oil to prevent bonding of the concrete.

Care Exercised in Handling Specimen

Following the completion of the curing, the specimen was moved from the casting base to the testing machine in the channel frame. To hold the slab securely in the frame during this operation, short steel dowels were cast in the concrete around the perimeter of the specimen. These extended through close-fitting holes drilled in the

web of the channel and supported the weight of the specimen in the frame when the latter was lifted. Figure 2 shows these details as one looks down into the casting form. Figure 3 shows a partially filled form before the vibrating of the concrete had been

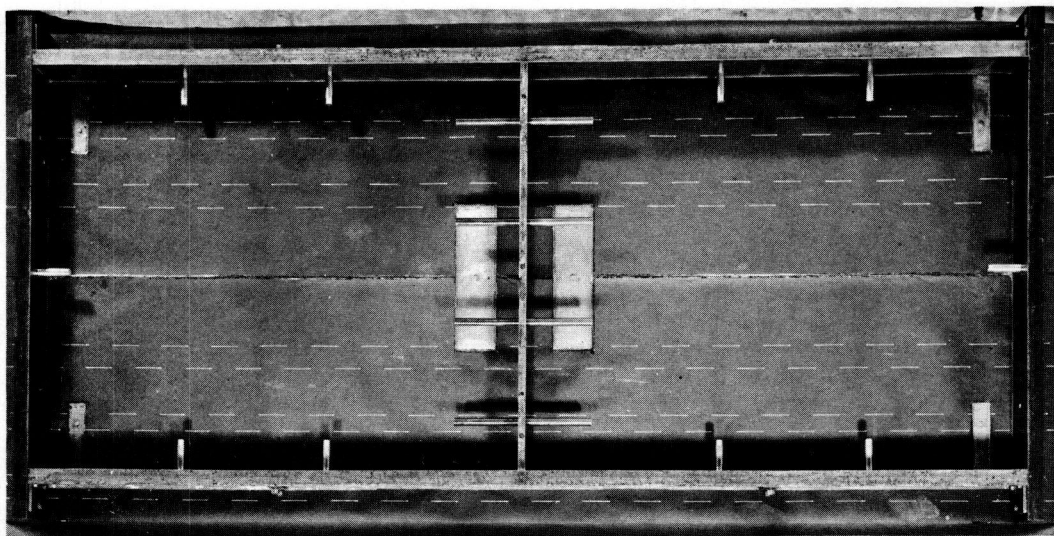

Figure 2. Looking down on the mold in which the specimens were cast.



Figure 3. Appearance of concrete during fabrication of a specimen; fluidity was obtained with internal vibrators.

started, and is included to give an idea of the character of the concrete mixture. Figure 4 shows a specimen in the frame being lowered into position in the testing machine. Once the specimen was properly placed, the form was disassembled and removed together with the steel partition used to create the joint opening. By this procedure all of the specimens were successfully handled and placed in the testing machines without damage to the joint system.

As stated earlier, the test was designed so as to make it possible to subject the load-transfer units under test to forces and motions that would simulate closely those which would be encountered in service. These requirements determined the general size of the specimens and the machine for testing them.

The earlier tests of full-size slabs at Arlington, Va. (2), had supplied data on the load-deflection relation of doveled joints in pavement slabs of several thicknesses. Data were obtained also on the angular motion that occurs when a slab end is deflected by load. This information was used to determine the dimensions of the support beams and, in turn, the length of the test specimen. Because of the indications of various analyses of dowel reactions and of the experiments referred to by Sutherland (5), it was decided to make the concrete specimen wide enough to permit the installation of four load-transfer units 12 in. apart. This led to the selection of the 48-in. width mentioned earlier. Since the experiments were expected to include load-transfer units of various sizes and strengths, the design of the machines provided for a range of loads and specimen depths. Vary few concrete highway pavements have been built with thicknesses of less than 6 in. or more than 10 in. For this reason, slab depths of 6, 8, or 10 in. were selected for study as stated previously.

From this description it is apparent that the test lends itself to studies of the structural behavior of load-transfer systems under conditions that approach those of actual service and provides a means for obtaining new and useful information on the effects of repetitive loading.

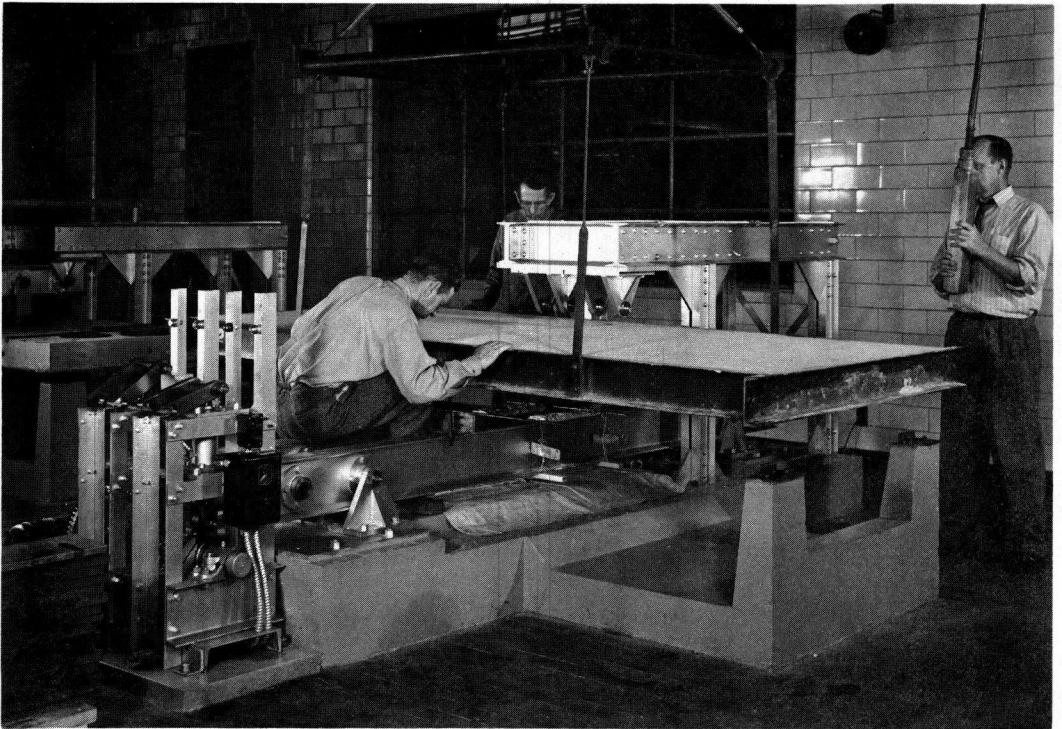

Figure 4. Lowering a cured specimen into the testing machine in the channel frame in which it was cast; the loading levers have been removed for this operation.

Impact conditions of load application have been purposely avoided: first, because a joint that causes appreciable impact is usually either a poorly constructed or a failed joint and, second, because impact is a complicated phenomenon difficult to control and to evaluate.

With the machine described it is possible to study any one of a number of variables that influence the structural performance of load-transfer systems. The work that has been done thus far has been largely confined to studies of the effects of the three variables of dowel diameter, dowel length, and width of joint opening. Certain collateral studies that were made for various reasons are described later.

TEST PROCEDURE BASED UPON PRELIMINARY STUDIES

After the completion of the first machine, it was necessary to make a number of preliminary studies to determine what the details of the test procedure should be to yield the most pertinent information in the least time. Some of the questions that needed to be answered were as follows:

1. How many cycles of loading would be required to produce significant comparisons and what additional information would be obtained by continuing the test beyond this point?
2. What strain and deflection data should be obtained and at what intervals should each measurement be made?
3. With two joint deflection values available, as the result of providing two span lengths for the support beams, what would be the relative effect of each on the test results?

The determination of the number of cycles of loading needed to develop significant data is an important matter. An effort was made to ascertain from traffic survey data how many wheel loads of approximately 10,000 lb might be applied at a given point on a transverse joint of a pavement on a heavily traveled route in the course of a year. It was found, however, that data on the transverse placement of wheel loads of this magnitude were not available, and the effort to relate the test duration to periods of pavement service was abandoned, at least for the early program. It was then decided to study the structural behavior of a few specimens under repeated loading; and, on the basis of these observations, make a decision on the question of test duration and others related to the test procedure.

As an important part of the preliminary studies, a representative specimen was subjected to a test in which a 10,000-lb load was applied alternately on either side of the joint 2 million times.

The specimen in this case was a slab 6 in. in depth; the joint opening was $\frac{3}{4}$ in.; the four dowels were $\frac{3}{4}$ -in. diameter; and the length of their embedment in the concrete on either side of the joint opening was 8-dowel diameters. The lesser span length of the support beams was used which resulted in a midspan deflection rate of 0.01 in. per 1,000 lb of applied load, assuming no load transfer across the joint.

The purpose of the test was primarily to develop general information required for the detailed planning of the testing procedure and the test program. As the loading cycle was repeated on this specimen, the program was interrupted at frequent intervals in order that measurements might be made of strains in the lower flanges of the support beams and deflections of the slab surfaces on either side of the joint opening. These measurements were made under a sequence of statically applied loads, the magnitude of which was varied from 2,000 to 10,000 lb by 1,000-lb increments.

From the differences in strain and the differences in deflection measured on the loaded and unloaded sides of the joint opening, values of relative strain and relative deflection were obtained. These terms appear frequently in the remainder of the report.

In this report, unless otherwise noted, all data pertaining to relative strains and relative deflections are based on the average of two sets of measurements, one set taken with the static test loads applied to one joint edge and the other taken with the same loads applied to the adjacent joint edge.

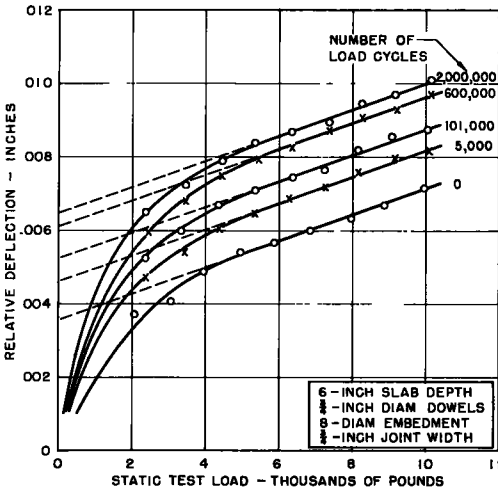

Figure 5. Relation between applied load and relative deflection, after various numbers of load cycles.

application of the first 5,000 lb of load the dowels were in a state of adjustment in which existing play or looseness was being taken up, and a condition of full bearing was being established. Once this condition had been attained the relation between increments of load and increments of relative deflection became constant. Thus, through the intercept values of the individual slopes on the Y-axis, the graph offers a means for estimating the amount of dowel looseness or play that was present at the beginning of the test, as well as the amount that resulted from repetitive loading.

Causes of Dowel Looseness

The term dowel looseness as used in this report includes all conditions that tend to prevent the dowel from offering full resistance to load. Conditions which may contribute to dowel looseness are coatings applied to prevent bond, water or air voids in the concrete, particularly under the dowel, shrinkage of the concrete during hardening, and wear of the dowel socket from repeated loading. The magnitude of the initial dowel looseness indicated in Figure 5 is 0.0035 in.

The high-bearing pressures between the dowel and the concrete, particularly in the region above and below the dowel near the face of the joint, tend to break down or wear the concrete during repetitive loading and thus increase whatever looseness may have existed initially. The data in Figure 5 indicate that in this test the 2 million cycles of load repetition and stress reversal caused the initial looseness to be increased by an additional 0.003 in.

The manner in which this looseness increased as the number of load repetitions increased, although evident in Figure 5, is shown in more detail in Figure 6. In the latter figure the increase in dowel looseness resulting from the repeated application of the 10,000-lb load is traced throughout the 2 million cycles of load application. The individual values were determined by the intercepts on the Y-axis of such curves as are shown in Figure 5. It is interesting to note in Figure 6 that the increase in looseness, developed during the first 40,000 cycles,

The data obtained in the testing of the specimen are shown in various ways in Figures 5-9, inclusive. These figures illustrate certain characteristics of behavior which were found to be common in all of the subsequent tests.

The relation between the statically applied loads and the corresponding relative deflections of the two slab surfaces, as determined after various numbers of loading cycles, is shown in Figure 5. Values of relative deflection were obtained from measurements made with micrometer dials directly above one of the dowels nearest the applied load.

From these data it is apparent that successive increments of load caused progressively smaller increments of relative deflection until the applied load was approximately 5,000 lb. From 5,000 to 10,000 lb the load-deflection relation is linear. This indicates that during the ap-

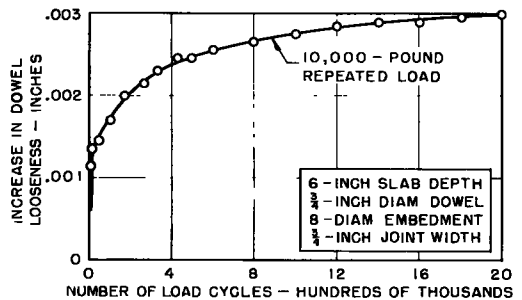

Figure 6. Effect of repetitive loading on the development of dowel looseness.

equals that developed by the subsequent 1,960,000 cycles.

As stated before, strain values measured in the lower flanges of the two support beams at midspan provide a direct measure of the amount of load being transferred across the joint opening by the load-transfer system. In the case of the representative specimen used in the preliminary studies, Figure 7 shows the relation between the statically applied load and the percentage of load transferred after various numbers of application of the 10,000-lb load, as determined from the strain data. In this graph the effect of the gradually increasing dowel looseness, under the repetitive loading, on the percentage of load transferred is quite evident.

This effect is brought out more clearly, however, in Figure 8 in which the loss in effectiveness of the load-transfer system is expressed as a percentage of its initial performance and traced throughout the 2 million cycles of load application. In this figure the loss in effectiveness for applied static loads of 10,000, 5,000, and 2,000 lb is shown. It is apparent that the load-transfer system is much more effective when the slab-end deflection is relatively large as is the case with the larger loads. The relatively rapid increase in dowel looseness during the early part of the test as indicated in Figure 6 is reflected in the strain data of Figure 8 also.

The data shown in Figure 5 indicated that the dowels in the joint of the representative specimen used in the preliminary tests became fully seated under an applied load of approximately 5,000 lb, and from that load to one of 10,000 lb the relation between load increments and increments of relative deflection was constant. The same is true for the relation between applied load and load transferred as measured by the strain data. This is brought out in Figure 9. It is of interest that once the play and looseness of the system is taken up the effectiveness of the system is relatively high, and even after 2 million repetitions of the application of the 10,000-lb load this effectiveness has remained practically unchanged.

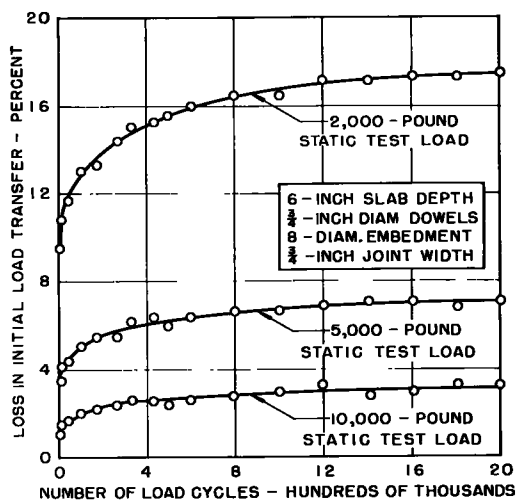

Figure 8. Loss in initial capacity to transfer load resulting from repetitive loading.

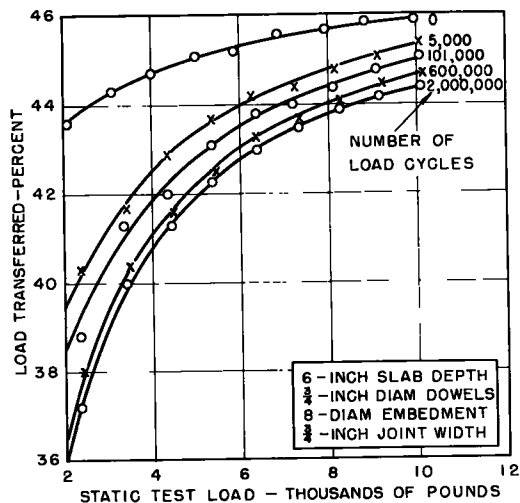

Figure 7. Relation between applied load and percentage of load transferred, after various numbers of load cycles.

PROGRAM OF LOADING AND OBSERVATIONS ADOPTED

From a study of the data obtained in the preliminary studies, a loading and observation schedule was adopted which was followed in testing all specimens covered by this report, with the exception of a few special cases.

As in the case of the preliminary tests with the representative specimen, the program of repetitive applications of the 10,000-lb (or 15,000-lb) load was interrupted at intervals to permit the application of a series of static test loads for which measurements of relative deflection and strain were made. The static test

loads ranged from about 2,000 to 10,000 lb by 1,000-lb increments. In general, no attempt was made to obtain data under the dynamic load cycle, although in a few tests, oscillograms of the strain data were obtained as will be discussed later. In making the measurements with the various static test loads, the load of a given magnitude was removed before the application of the load of the next higher magnitude.

For each load increment, measurements were made with micrometer dials to determine the relative deflection of the slab surfaces at the joint. With four equally spaced dowels in the system, the loading pad was located midway between the two central dowels. The measurements of relative deflection were made close to the joint edge and directly over one of the two central dowels.

Also for each load increment, strains were measured at several points. The relative strains in the lower flanges of the two support beams provided information as to the amount of load being transferred by the dowels. Strain in the upper surface of the concrete specimen in the direction of the joint edge and at midlength of the joint gave information on the transverse bending stress in the concrete. In addition, bending stresses in individual dowels were determined by means of strain gages at static test loads of approximately 2,000, 5,000, and 10,000 lb.

The measurements just described were made before the beginning of the application of repetitive loads and after 5,000, 15,000, 40,000, 100,000, 200,000, 300,000, 400,000, 500,000, and 600,000 load cycles. This frequency was adequate to establish the behavior pattern of the various specimens without being unduly time consuming.

On the basis of the preliminary studies it was decided to terminate the repetitive loading test on a given specimen after 600,000 cycles. The data showed that significant changes developed before this number of cycles had been applied, and that changes between this number and 2 million cycles were very small. What this represents in terms of traffic is not known, as was stated earlier. However, 600,000 applications of a 10,000-lb load at a given spot on the joint edge of a pavement under traffic must be representative of a considerable period of service on many highways. From the standpoint of the test program, the application of 600,000 cycles of loading required six weeks as a minimum, and this seemed to be about all the time that should be devoted to one test specimen.

After preliminary tests and consideration of the data, it was decided to use span lengths for the support beams that would cause a midspan deflection of 0.01 in. for an applied load of 1,000 lb, assuming no load transfer across the joint. With an applied load of 10,000 lb, as in a test, the midspan deflection would then be approximately 0.10 in. with no load transfer or 0.05 in. with the assumed ideal condition of complete load transfer. This deflection rate is somewhat greater than that which usually prevails at a transverse joint edge of a fully supported concrete pavement slab. Many slab ends are not fully supported, however, and deflection rates of the magnitude just mentioned have been measured. From the testing standpoint it was believed that data developed at the rate selected would be more sensitive to structural deterioration in the load-transfer system than those which were developed at a lesser rate.

Twenty-nine specimens were tested in the studies of the three variables of dowel diameter, length of dowel embedment, and width of joint opening. One specimen (the first) was carried through only 57,000 loading cycles and the data are not included; two were used in special tests outside the program. Thus, 32 specimens in all were constructed.

Of the 29 specimens in the studies of the three major variables, eight were used in studies of the effects of dowel diameter, 20 in the studies of length of dowel embedment, and eight in the studies of the effect of width of joint opening. The data from certain specimens could be used for more than one comparison which accounts for the apparent discrepancy in numbers of specimens.

The dowel diameters used in the tests were $\frac{5}{8}$ in., $\frac{3}{4}$ in., $\frac{7}{8}$ in., 1 in., $1\frac{1}{8}$ in., and $1\frac{1}{4}$ in. In the studies of the effect of length of dowel embedment, a constant width of joint was used throughout; and the lengths of embedment, expressed in dowel diameters, ranged from 2 to 12. The actual dowel lengths are shown in Table 1. The widths of joint opening used in the tests were $\frac{1}{16}$ in., $\frac{1}{2}$ in., $\frac{3}{4}$ in., and 1 in.

The amount of load that can be transferred by a dowel or dowel system depends upon (a) the load carrying capacity of the dowel under the most favorable conditions, (b) the amount by which this optimum capacity is reduced by what has been termed initial dowel looseness in this report, and (c) the amount by which initial capacity to transfer load has been reduced by subsequent repetitive loading. Accordingly, the data obtained in the major part of the test program being reported are presented and discussed in the order mentioned.

TABLE 1
ACTUAL DOWEL LENGTHS INCLUDED
IN THE STUDY OF LENGTH OF
DOWEL EMBEDMENT

Diameters of Dowels (in.)	Lengths of Dowels (in.)			
$\frac{3}{4}$	3.75	6.75	12.75	18.75
1	4.75	8.75	16.75	24.75
$1\frac{1}{4}$	5.75	10.75	20.75	-

LOAD TRANSFER UNDER IDEAL CONDITIONS

In the discussion of Figure 5 earlier in the report, it was noted that the relation between increments of applied load and increments of relative deflection of the abutting slab edges did not become constant until a static test load value of about 5,000 lb was reached. It was concluded that at this point a condition of full bearing of the dowel in the concrete socket had been established. The linear portion of the relation which was found for the higher loadings thus may be taken as representative of true elastic deformation of the dowel and the concrete, and hence a means by which the capacity of the system to transfer load under the most favorable conditions can be determined.

It was decided that for studying the effects of varying dowel diameter, length of dowel embedment, and width of joint opening a useful index would be the amount of dowel deflection resulting from a shear load of 1,000 lb—the term dowel deflection representing relative deflection with the dowel in full bearing on the concrete. Such an index could be obtained from the linear portion of the load-relative deflection relations, such as those shown in Figure 5, by any one of the three methods described briefly in the following paragraphs.

Method 1. Loads ranging from 5,000 to 10,000 lb by 1,000-lb increments were applied. Relative deflections were measured over each of the four dowels. Average shear in the load-transfer system was determined from strain values in support beams and related to average relative deflection values. This method was used in 19 tests.

Method 2. Applied loads were the same as in Method 1. Relative deflections were measured over one dowel adjacent to the load only. Shear value for this particular dowel was arrived at by distributing total shear among the four dowels according to value of bending strains in each one. Each point defining the relation is an average of 10 test values. This method was used in 18 tests.

Method 3. After completion of the regularly scheduled test on a 4-dowel system, the two outer dowels were cut through so that only the two central dowels remained active. Average shear and relative deflection values were obtained as in Method 1. This procedure was used in 12 tests.

In four tests all three methods were used and in the majority of the remainder two methods were used. Typical data from the three methods on a single specimen are shown in Figure 10. For convenience in presentation the straight lines were drawn to pass through the origin (although the origin for Method 3 is off the graph). It was concluded that essentially the same index value was obtained by each method. Where two or three methods were used on a single specimen, the values obtained were averaged.

EFFECT OF DESIGN FEATURES ON LOAD TRANSFER

In Figures 11-14 the dowel-deflection index values just described have been utilized to study the effects of varying the principal design features of dowel diameter, length of dowel embedment, and width of joint opening. The index values provide a measure of the relative load-transfer capacity for the particular conditions involved. The larger the index value, the less effective is the system.

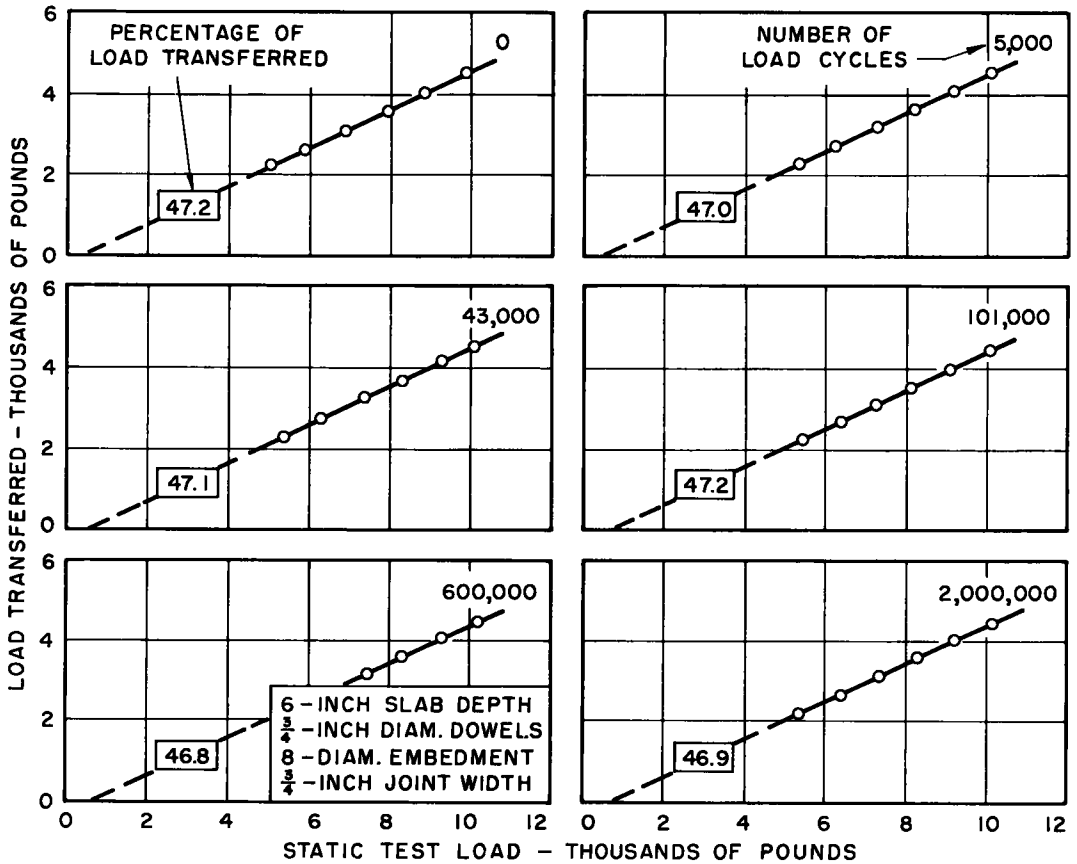

Figure 9. Relation between applied load and amount of load transferred, after various numbers of load cycles.

Dowel Diameter

In Figure 11, the dowel-deflection index data are utilized to show the effect of variations in dowel diameter. These data are from tests in which the width of joint opening was $\frac{3}{4}$ in. As indicated, four of the values were for a 6-in. slab depth, two for an 8-in. slab depth, and one for a 10-in. slab depth. Thus some information is provided on the influence on dowel deflection of the depth of concrete above and below the dowel.

If one considers a dowel as a cantilever being deflected by a vertical force equal to the shear on the dowel, it is apparent that the deflection at the point of load application will be the result of (a) the deformation of the concrete under the bearing load exerted by the dowel, (b) the angular change in direction of the dowel axis resulting from the deformation of the concrete, and (c) the elastic bending of the dowel itself.

In his analysis of dowel design, Friberg (4) considered each of these factors and combined them in a single formula for the deflection of a dowel crossing a joint. It is of interest to compare the values of dowel deflection observed in the experiments being reported with corresponding values computed by Friberg's formula (see appendix), utilizing the elastic properties which existed in the present tests. This comparison is made in Figure 12 in which the deflection values determined experimentally for the four dowel sizes in the specimens of 6-in. depth are shown as plotted points, while the relation obtained with the formula is shown as the solid line. It is apparent that the relation between dowel diameter and dowel deflection is an exponential one in each case, although the value of the exponent found in these experiments is somewhat different than that in the theoretical formula. For the dowel diameters greater than $\frac{3}{4}$ in., it is ap-

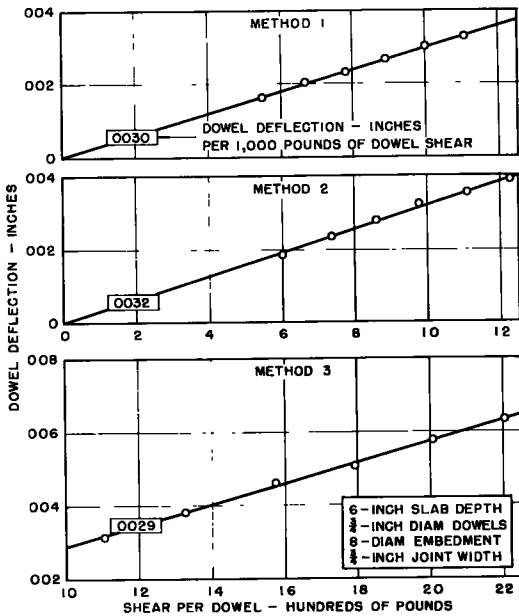

Figure 10. Typical relations between dowel shear and dowel deflection.

eter dowel and a 3/4-in. joint opening, maximum resistance is obtained with an embedment of about 6 diameters, whereas for a 1 1/4-in. diameter dowel an embedment of about 4 diameters develops maximum resistance. It should be borne in mind that these embedment lengths are for concrete of relatively high strength and for dowels that are embedded with unusual care. Whether the same relations would hold for concrete of lesser strength can only be determined by further tests. Such tests should be made, as the present data point to the possibility of a considerable savings in steel requirements for dowels, particularly with the larger diameter dowels now coming into use.

Width of Joint Opening

In Figure 14 the dowel-deflection index values are arranged to show the effect of increasing the width of joint opening. The data are for a dowel embedment of 8 diameters in all cases. The dowel diameters are 3/4 in., 1 in., and 1 1/4 in. and the depth of the slab varies with dowel diameter in the manner indicated. As would be expected, there is a marked increase in dowel deflection as the width of joint opening is increased, the deflection of a given dowel size being approximately doubled as the width of opening is increased from 7/16 to 1 in. This indicates that a given dowel size provides approx-

parent also that the deflection values found in the present experiments are quantitatively not greatly different from those computed by the formula.

Length of Dowel Embedment

The deflection index data may be used also to study the effect of varying the length of embedment (or bearing on the concrete) on the ability of the dowel to resist loads. In Figure 13, dowel-deflection index values are shown for three dowel diameters (3/4 in., 1 in., and 1 1/4 in.) and for a range of lengths of embedment from 2 to 12 diameters. The width of joint opening was 3/4 in. in all cases. It will be observed that the greater the stiffness of the dowel itself, the less the length of its embedment, in terms of dowel diameter, influences the deflection.

The relation shown for the 3/4-in. diameter dowel indicates that for a width of joint opening of 3/4 in. an embedment of about 8 diameters is required to develop maximum resistance. For a 1-in. diam-

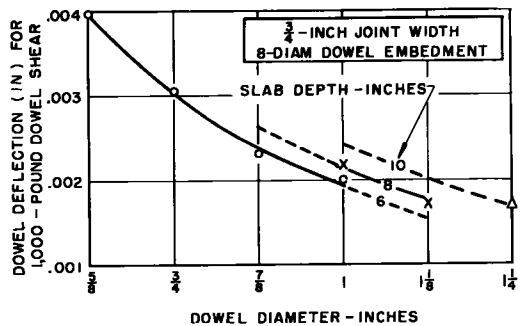

Figure 11. Relations between dowel diameter and dowel deflection.

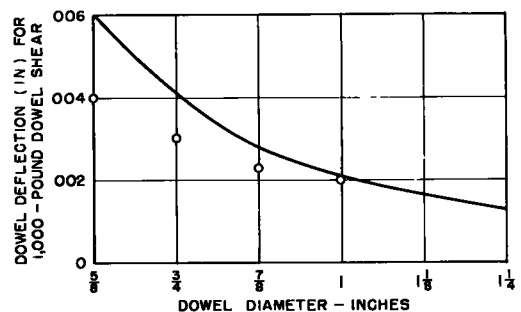

Figure 12. Comparison of theoretical and observed relations between dowel diameter and dowel deflection.

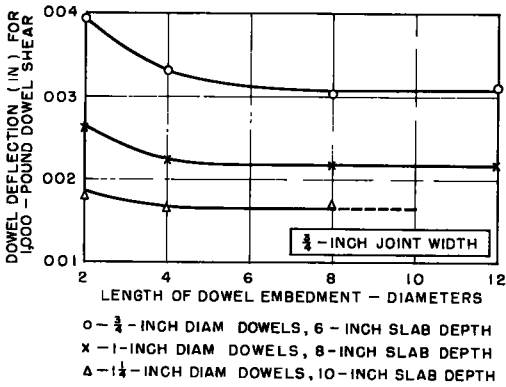

Figure 13. Relations between length of dowel embedment and dowel deflection.

ciably more load transfer in a contraction joint than in an expansion joint, other conditions being the same. The influences of dowel diameter and the depth of the concrete above and below the dowel that were noted earlier are apparent in this graph also.

SIGNIFICANCE OF DOWEL DEFLECTIONS

The effectiveness of a load-transfer system can be measured by the amount it reduces free-edge load stress or by the amount it reduces free-edge load deflection. The two criteria are related but are not necessarily the same, and their relative importance depends upon the over-all

structural design of the pavement. In the tests being reported, the effects of repetitive loading on slab deflections rather than on slab stresses are being studied.

One measure of the extent of load being transferred across a pavement joint by a dowel or other load-transfer unit is the amount by which the magnitude of the free-edge deflection of the pavement, under a given applied load, is reduced by the presence of the load-transfer unit. This relation was discussed in the report of the Arlington tests (2) (see Public Roads, Vol. 17, No. 7). Subsequently it was expressed for the case of a single dowel in a formula by Friberg in his ASCE paper (4) and by Richart and Bradbury in discussions of Friberg's Highway Research Board paper (4). While the form of the expression used by the three authors differed somewhat, the relation expressed was basically the same. The derivation is based on the premise that the deflection of the pavement edge on which the load is applied must equal the deflection of the dowel plus the deflection of the adjacent slab edge. Thus the load applied to the latter through load transfer is equal to the dowel shear. For the relation to hold, it is implicit that either there be no looseness of the dowel in its socket or any existing looseness be eliminated.

The proportionate part of the applied load that is transferred to the adjacent slab by the dowel may be obtained from the following expression:

$$p = \frac{1}{2 + \frac{y_d}{y_p}} \quad 100 \quad (1)$$

in which:

- p = proportion of load transferred, in percent;
- y_d = dowel deflection caused by unit shear, in inches; and
- y_p = free-edge deflection of the pavement caused by unit load, in inches.

The expression indicates that under the ideal conditions assumed and within the elastic range of the materials involved the percentage of load transferred is independent of the load magnitude. It shows also that the percentage depends upon the relative stiffnesses of the dowel and of the pavement and, in turn, those factors which affect the stiffness of either.

In Figures 15-17, experimental dowel

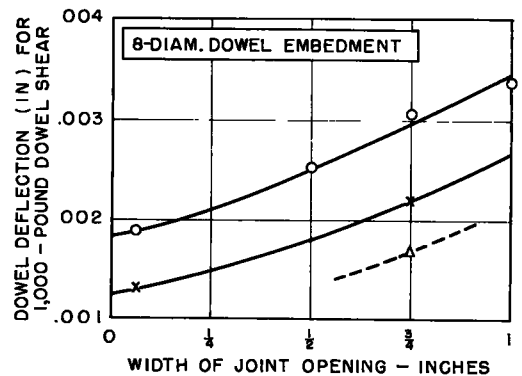

Figure 14. Relations between width of joint opening and dowel deflection.

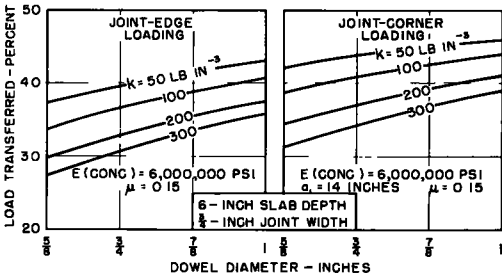

Figure 15. Effect of dowel diameter on load transfer in the case of a single dowel.

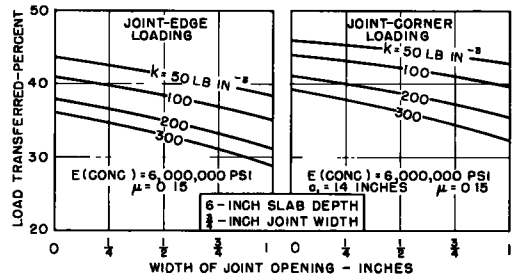

Figure 16. Effect of width of joint opening on load transfer in the case of a single dowel.

stiffness (deflection) data taken from Figures 11 and 14 have been combined with pavement stiffness (deflection) values computed with Westergaard's equations (see appendix) in the expression given as Eq. 1 to bring out the inter-relationships that exist between dowel size, width of joint opening, slab depth, and modulus of subgrade reaction. These comparisons apply to a single dowel.

Figure 15 shows, for the two cases of joint-edge and corner loading, the relations between dowel diameter and percentage of load transferred, as the modulus of subgrade reaction, k , is varied from 50 to 300 pci. It is indicated for the conditions stated that an appreciable increase in the percentage of load transferred is obtained by increasing the diameter of the dowel, the rate of the increase becoming greater as the supporting power of the subgrade becomes greater. For example, as the subgrade modulus, k , is changed from 50 to 300 pci, the rate, as expressed by the increase in percentage of load transferred per $\frac{1}{8}$ -in. increase in dowel diameter, increases from 1.90 to 2.77 for edge loading and from 1.23 to 2.57 for corner loading.

Two important structural benefits are obtained as the diameter of the dowel is increased: increased dowel rigidity with better load-transfer ability and greater bearing area on the concrete with reduced bearing pressures immediately above and below the dowel.

The effect of changing the width of the joint opening on the percentage of load transferred by a single dowel is shown in Figure 16 for the two cases of loading with the same pavement depth and range of values of the subgrade modulus, k , mentioned in the discussion of Figure 15. It is indicated by these relations that as the stiffness of the subgrade becomes greater the effect of joint width on load transfer becomes greater also.

In Figure 17, the theoretical relation between the percentage of load transferred and the dowel stiffness is shown in a somewhat different manner. By means of the Westergaard equations and for the conditions stated, the relation between load and deflection was established for the free edge and free corner of pavement slabs of 6-, 8-, and 10-in. depths. These deflection values were used in Eq. 1 to obtain the percentage of load transferred by a single dowel as the stiffness of the dowel was varied for each of the three slab depths just mentioned. The resulting relations are shown in Figure 17 as a family of three full-line curves. In this group of theoretical relations, the observed experimental dowel deflection values have been shown as plotted points.

Figure 17 is of particular interest because any horizontal line, such as the

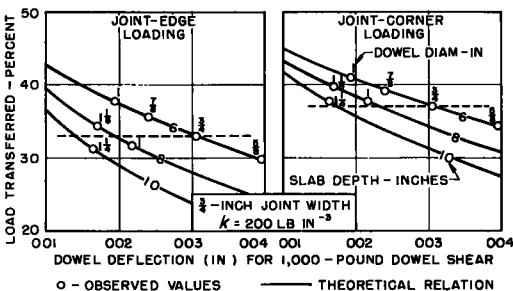

Figure 17. Effect of dowel deflection (dowel stiffness) and slab depth (pavement stiffness) on load transfer in the case of a single dowel.

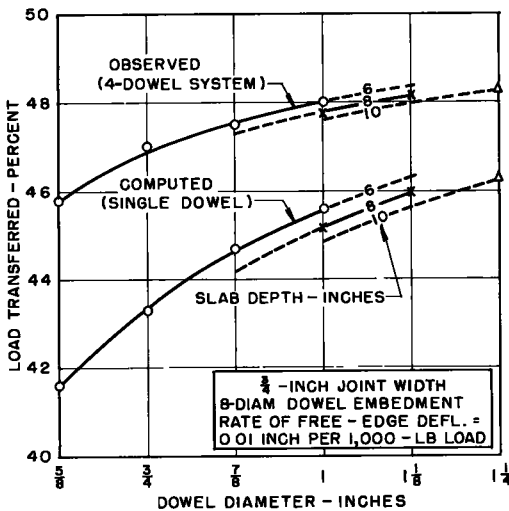

Figure 18. Observed percentages of load transfer of 4-dowel system compared with computed values of a single dowel for a range in dowel diameters.

in eighths of an inch should equal the pavement depth in inches.

LOAD-TRANSFER CAPACITIES OF SINGLE AND MULTIPLE DOWELS COMPARED

The discussion of load transfer up to this point has been confined to that provided by a single dowel functioning under ideal conditions. In the investigation being reported for reasons stated earlier, a system of four dowels was used in each specimen and the deflections of the joint edge under the loads used were relatively large as pavement deflections go. The tests do provide some comparative data, however, and it is of interest to examine the comparison between the single dowel and the 4-dowel system for the three major variables of dowel diameter, length of dowel embedment, and width of joint opening as shown in

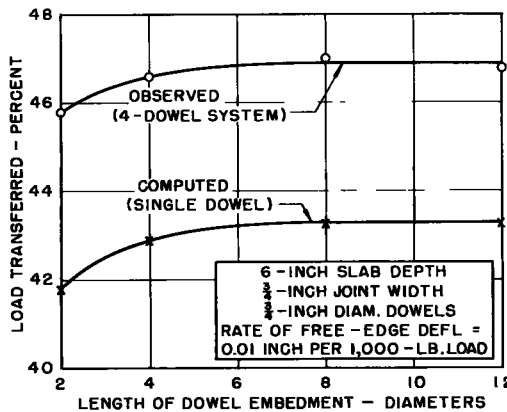

Figure 19. Observed percentages of load transfer of 4-dowel system compared with computed values of a single dowel for a range in lengths of dowel embedment.

dashed-line shown, indicates a relation between slab depth and the size of dowel necessary to accomplish a given percentage of load transfer. For example, it indicates that for pavements of 6-, 8-, and 10-in. depths, dowels of 3/4-, 1 1/16-, and 1 3/8-in. diameters, respectively, might be expected to effect the same percentage of load transfer for the joint-edge loading; and that dowels of 3/4-, 1-, and 1 1/4-in. diameters would do the same for the joint-corner loading.

It is realized that the experimental data on which this relation is based are somewhat meager, particularly for the 8- and 10-in. slab depths. However, it is believed that the analysis is a valid one, and it is to be noted that the relation indicated is concordant with the recommendations of the American Concrete Institute (8). It might be stated as an approximate rule, as follows: For round steel dowels at 12-in. spacing with a joint opening of 3/4 in. or less, the diameter of the dowel

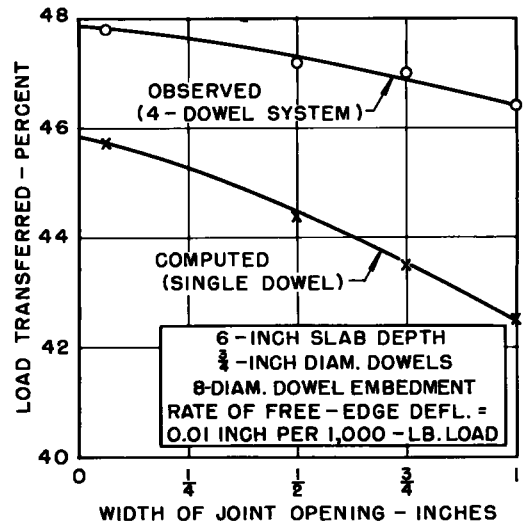

Figure 20. Observed percentages of load transfer of 4-dowel system compared with computed values of a single dowel for a range in widths of joint opening.

Figures 18, 19, and 20, respectively.

In preparing these figures the load-transfer capacity values for the 4-dowel system were obtained in the manner described in connection with Figure 9, each value being based on ten individual tests with a given dowel system. The comparative values for the single dowel were computed by Eq. 1 using dowel stiffness data given in Figures 11, 13, and 14, and a free joint-edge deflection rate of 0.01 in. per 1,000 lb of applied load. It is important to keep in mind that the relations shown in these graphs represent performance under the most favorable or optimum conditions. This and the relatively high deflection rate which applies to these test values explain the high percentages of load transfer shown in the graphs.

Stated in another way, the percentages shown would be found only where the dowel functioning was perfect and where there was relatively weak subgrade support on both sides of the joint. Had the deflection rate been smaller, as would be the case with a stronger subgrade, or had the dowel action been less than perfect, or both, the general level of load transfer would have been lower. Regardless of the magnitude of the load-transfer percentages, the comparison between the performance of the 4-dowel system as observed in the tests and that of the single dowel as computed by the formula is believed to be valid and of interest in the analysis of the data.

As will be observed in Figures 18-20, the trends for the three major variables of dowel diameter, length of dowel embedment, and width of joint opening are essentially the same for the 4-dowel system and the single dowel. It is evident that a good correlation exists throughout; and, for a given percentage of load transferred by the single dowel, an essentially constant numerical difference exists between the load-transfer capacity of the 4-dowel system and the single dowel, irrespective of relations for dowel diameter, length of embedment, or width of joint opening.

Whether or not this generalization would hold for other rates of joint-edge deflection was not established definitely by these tests. However, an analysis of the data from six tests in which the free-edge deflection rate was double that shown in Figures 18-20 indicates that it might apply; and, on the assumption that it does, Figure 21 was prepared to show the general effect of the stiffness of the support afforded by the subgrade on the load-transfer capacity of a dowel or dowel system.

The computed values shown as plotted points were obtained with Eq. 1, using dowel deflection rates from the tests being reported, slab-edge deflection rates computed by means of the Westergaard equations for the values of the subgrade modulus, k , and the relation between single and multiple dowel load-transfer characteristics established by the data shown in the preceding graphs. The observed dowel deflection rates for the $\frac{3}{4}$ -in. diameter dowel in a 6-in. depth slab, the 1-in. diameter dowel in an 8-in. depth slab and the $1\frac{1}{4}$ -in. diameter dowel in a 10-in. depth slab were utilized in the computations.

Of the several comparisons available for ideal conditions represented in Figure 21, probably the most significant is one which shows how the stiffness of the subgrade support influences the load transfer that can be obtained with a given system. As has been stated, it was for this reason that Figure 21 was prepared.

EFFECT OF INITIAL DOWEL LOOSENESS ON LOAD TRANSFER

The discussion thus far has been concerned principally with dowel performance with looseness eliminated. Early in the report, dowel looseness was defined as including all conditions that tend to prevent the dowel from offering full resistance to load. Among the conditions which contribute to dowel looseness were mentioned coatings

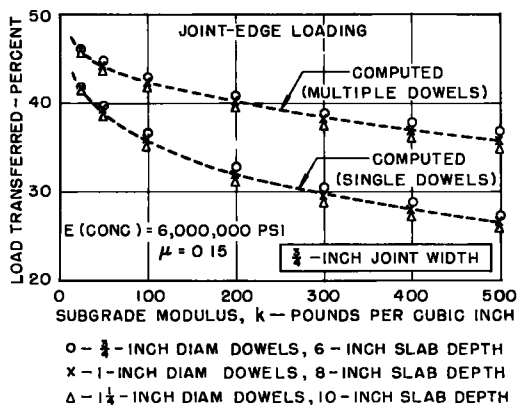

Figure 21. Load-transfer percentages computed for single and multiple dowels for a range in subgrade support values.

used to prevent bond, air or water voids in the concrete, shrinkage of the concrete during hardening, and wear of the dowel socket during repetitive loading.

It may safely be assumed that some initial looseness will always exist in doweled joints as they are built in practice, and the effect of such looseness on load transfer is a matter of considerable interest.

It is obvious that a dowel or dowel system does not begin to function at maximum efficiency until all initial looseness is taken up by deflecting the pavement on the loaded side of the joint farther than would be necessary if initial looseness were not present. Thus the effect of looseness is to reduce the potential usefulness of the load-transfer system by an amount that depends upon the degree of dowel looseness that exists.

If it is assumed that slab deflection is proportional to applied load and, in general, this is a valid assumption (see Public Roads, Vol. 23, No. 8) (2), the loss in potential load-transfer capacity resulting from initial looseness in the load-transfer system can be expressed for a given load as follows:

$$\Delta p = \frac{l_i}{y} 100 \quad (2)$$

in which:

Δp = loss in potential load-transfer capacity, in percent;

l_i = initial looseness in load transfer system, in inches; and

y = free-edge deflection of the pavement caused by the load in question, in inches.

The expression indicates that the loss in potential load carrying capacity, while independent of the capacity of the system, increases directly with the magnitude of the initial looseness and decreases as the magnitude of the free-edge deflection increases.

In Figure 22 are shown data on the initial looseness for the dowel systems of various specimens tested in the investigation being reported. The values were determined in the manner shown in Figure 5, that is, by extending the linear part of the relation shown before repetitive loading was started to its intercept with the Y-axis. In Figure 22 the values are grouped according to the design variables of dowel diameter, length of dowel embedment, and width of joint opening.

It is apparent that the values shown tend to be erratic among the various specimens. The magnitudes are all relatively small, ranging from 0.0015 to 0.0045 in. There is no apparent trend with either length of dowel embedment or with width of joint opening. There does appear to be a rather systematic decrease in initial looseness as the diameter of the dowels is increased, however.

The effect of initial looseness of a dowel system in reducing its potential capacity to transfer load is shown for stated conditions in Figure 23. The loss values in this figure are differences between load transfer for the ideal condition of no initial looseness and that observed for the first load cycle when only initial looseness was present. The theoretical or computed relation was established with Eq. 2, using a free-edge pavement deflection of 0.1 in. and assumed values of initial dowel looseness. Figure 23 shows good agreement of observed data with the relation as computed.

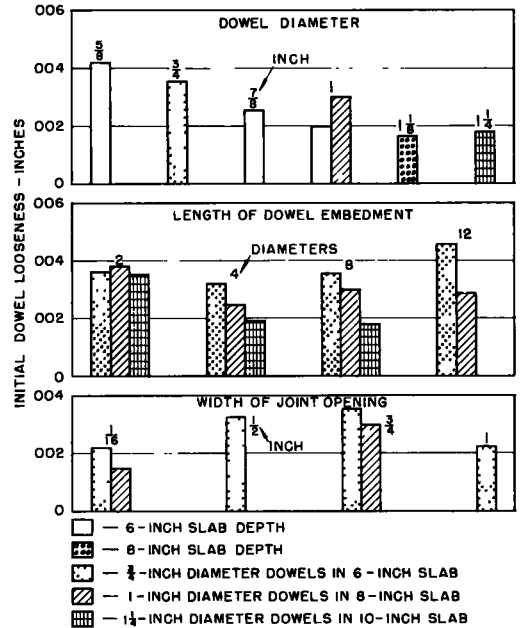

Figure 22. Data on initial dowel looseness.

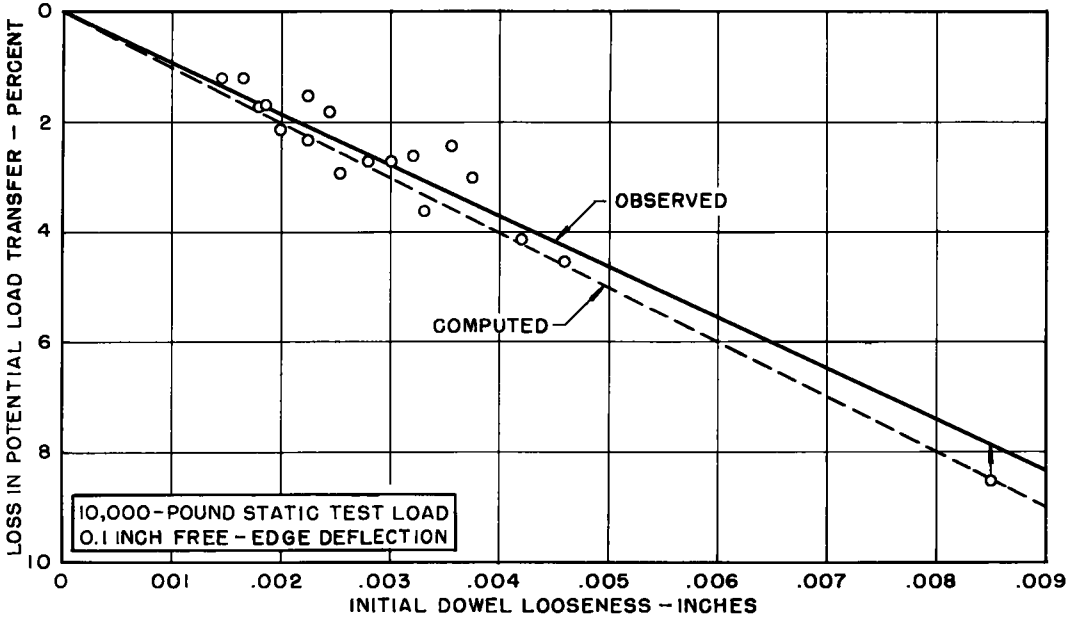

Figure 23. Relation between initial dowel looseness and loss in potential ability to transfer load.

The plotted point on the right-hand side of Figure 23 at an initial looseness value of 0.0085 in. is of interest. It represents a condition encountered in one of the first specimens to be constructed. The dowels were held in a partition form of dry wood. The swelling of the wood as it absorbed moisture from the concrete is believed to have

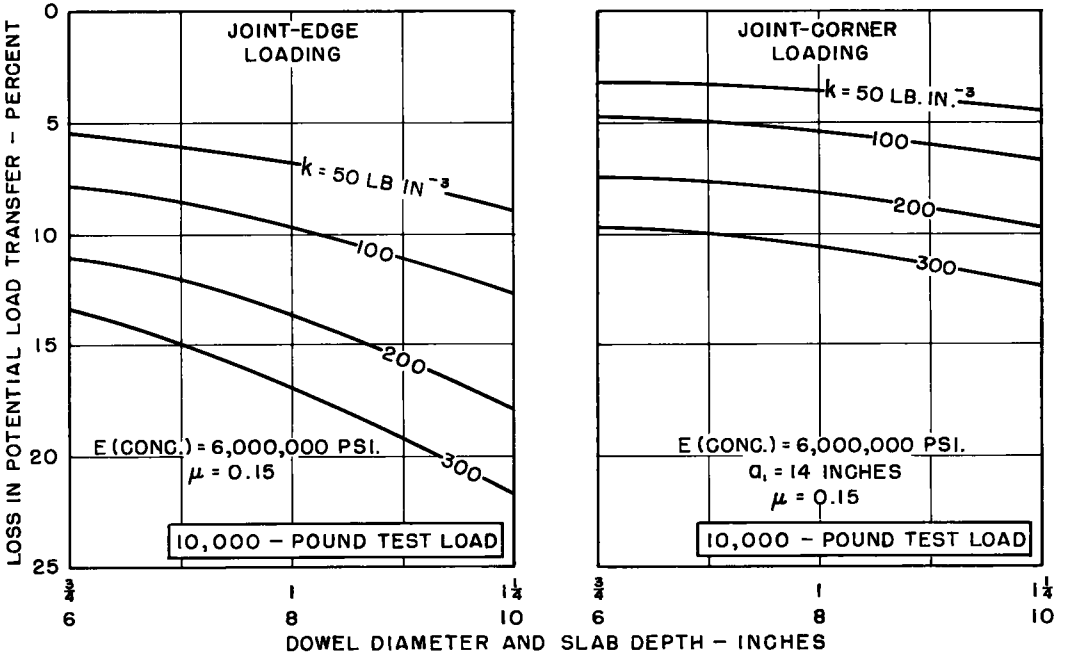

Figure 24. Effect of initial dowel looseness on loss in potential ability to transfer load for certain combinations of dowel diameter and slab depth.

caused enough vertical movement of the dowels to develop the unusual looseness observed in this specimen. Subsequently, the wood partition was submerged in water for at least 24 hr, and this resulted in a marked improvement. However, after a few specimens had been made, the use of wood was abandoned and a removable steel partition was built and used in the construction of a majority of the specimens. This eliminated the possibility of any water absorption.

Figure 24 shows certain derived relations, based on observed data and theory, designed to bring out the practical significance of initial looseness in a doweling system. The test specimens selected for analysis were as follows:

Dowel Diameter, in inches	Slab Depth, in inches,	Initial Looseness, Average All Specimens, in inches
3/4	6	0.0032
1	8	0.0026
1 1/4	10	0.0024

The relations shown in Figure 24 were obtained for these three cases by means of Eq. 2, utilizing the Westergaard formulas for computing values of free-edge deflection for a 10,000-lb load and selected values of the modulus of subgrade reaction. These relations are useful in making evident the important losses in load-transfer capacity that can be caused by relatively small degrees of initial looseness in the doweling system, particularly for firmer subgrades and thicker pavements where load-deflection magnitudes are small.

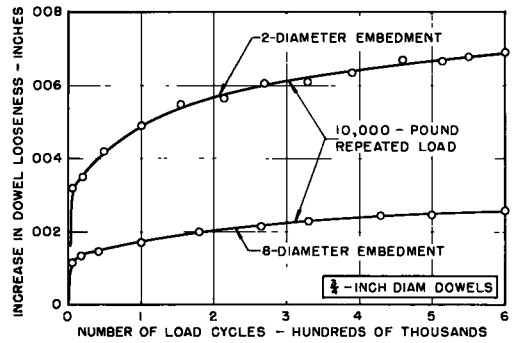

Figure 25. Effect of length of dowel embedment on the development of dowel looseness under repetitive loading.

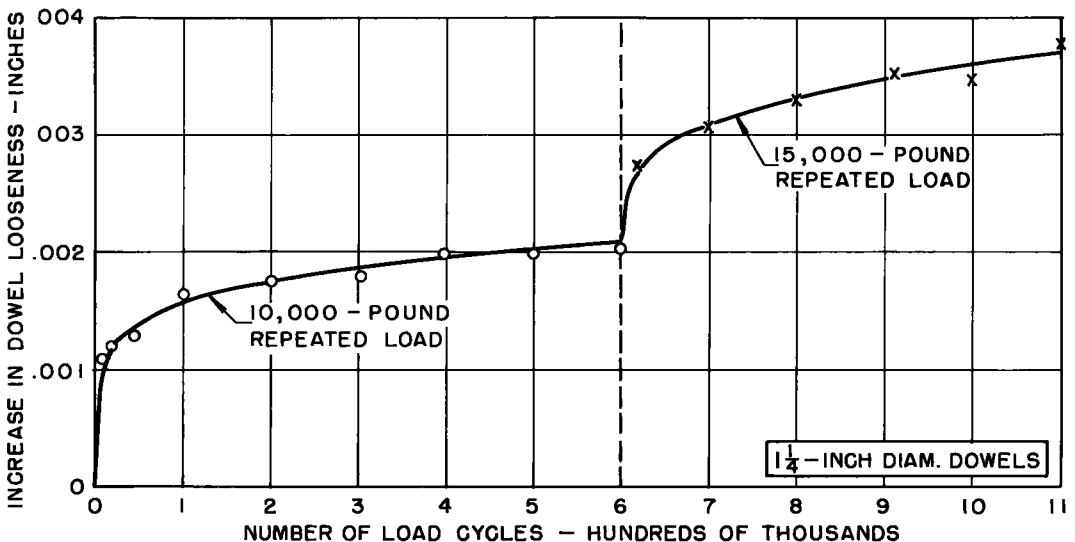

Figure 26. Effect of increasing the magnitude of the repeated load on the development of dowel looseness.

EFFECT OF REPETITIVE LOADING ON LOAD TRANSFER

The load repetitions and load reversals, as applied in these tests, caused a progressive increase in the looseness of the dowels as it existed initially. The increase in looseness was accompanied by a progressive loss in load-transfer capacity, as would be expected. This change under repetitive loading is attributed to a breakdown or wear in the concrete of the dowel socket above and below the dowel, particularly in the region near the joint face, caused by the repeated application of intense bearing pressure.

It is of interest to note that after as many as 2 million cycles of the application of a 10,000-lb load at a joint containing four $\frac{3}{4}$ -in. diameter dowels, the wear or "funneling," as it is sometimes called, was

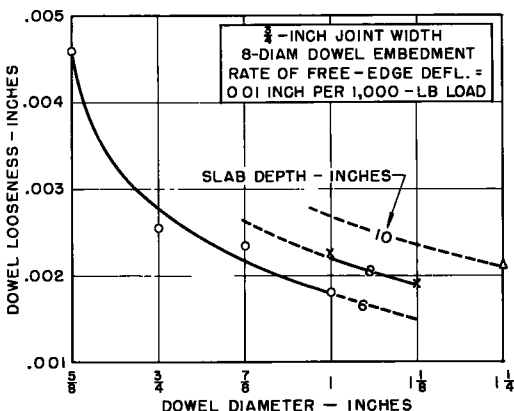

Figure 27. Relations between dowel diameter and dowel looseness resulting from 600,000 cycles of a 10,000-lb load (base measurements obtained at first cycle).

so small as to be undetectable by visual examination. The change was readily measurable with the instrumentation used in the tests, however. Typical test data are shown in Figures 25 and 26.

In Figure 25, the effect of embedment length is shown to be an important variable affecting both the magnitude and the rate of development of the looseness caused by repetitive loading.

The load magnitude is shown in Figure 26 to be an important variable. After the rate of increase of looseness had reached a very small value following the application of 600,000 cycles with the 10,000-lb load, an increase of load to 15,000 lb brought about an immediate increase in the rate of development of further looseness, a change which had not completely stabilized after an additional 500,000 cycles of this loading.

These figures are of interest because they show the manner in which looseness of the dowel develops under repetitive loading and indicate some of the variables involved.

In these tests, measurements of the relative deflection of the joint edges provide information concerning the initial looseness in the load-transfer system and the manner in which this initial looseness increases as the dowels are subjected to repetitive loading. Measurements of relative strain provide information on the changes in the load transferring ability of the dowel system as the repetitive loading proceeds. From the data obtained, it is possible to relate the data from the two types of measurement.

Considering first the changing magnitude of dowel looseness as the dowel system is subjected to load repetition and complete stress reversal, the data have been examined from the standpoint of the three design variables—dowel diameter, length of dowel embedment, and width of joint opening. The effects of each of these variables on the development of dowel looseness under repetitive loading are shown in Figures 27, 28, and 29. In each of these graphs, the magnitude of the looseness resulting from the application of 600,000 cycles of a 10,000-lb load forms the basis of comparison and is

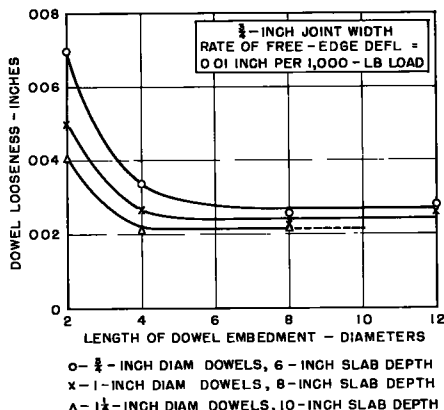
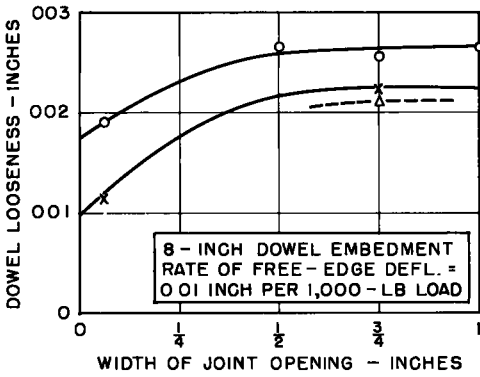

Figure 28. Relations between length of dowel embedment and dowel looseness resulting from 600,000 cycles of a 10,000-lb load (base measurements obtained at first cycle).



○ - $\frac{3}{4}$ -INCH DIAM. DOWELS, 6-INCH SLAB DEPTH
 x - 1-INCH DIAM DOWELS, 8-INCH SLAB DEPTH
 Δ - $\frac{1}{4}$ -INCH DIAM DOWELS, 10-INCH SLAB DEPTH
 Figure 29. Relations between width of joint opening and dowel looseness resulting from 600,000 cycles of a 10,000-lb load (base measurements obtained at first cycle).

dowel looseness. The actual magnitude of the looseness is affected, however, since the greater the free-edge deflection rate the greater the looseness, other conditions being constant.

The rate of development of dowel looseness under repetitive loading would be expected to depend primarily upon three factors: intensity of the bearing pressure between the dowel and its concrete encasement, the number of load applications, and the strength of the concrete. The present tests have thrown considerable light on the effects of both pressure intensity and the number of load applications, but not on the effects of variations in the strength of the concrete because, as was stated earlier, every effort was made to have the concrete uniform and of high quality.

Since the development of dowel looseness under repetitive loading leads directly to a reduction in the load transferring

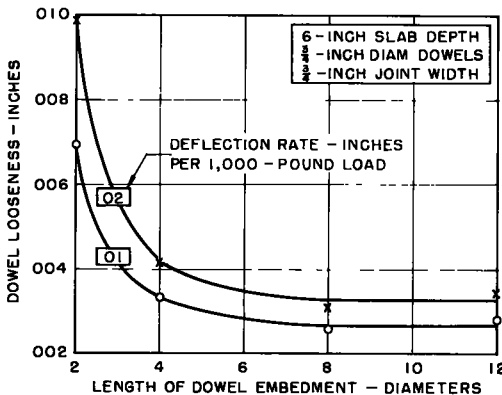

Figure 30. Comparison of dowel looseness developed at 0.01-in. and 0.02-in. free joint-edge deflection rates after 600,000 cycles of a 10,000-lb load.

related to the several design variables for the other test conditions stated.

It is apparent from the relations shown in these graphs that the dowel looseness caused by the application of 600,000 cycles of repetitive loading is, in general, rather small—its magnitude being no greater than that which existed before the application of the loads, as shown in Figure 22.

The values of dowel looseness shown in Figures 27-29 were obtained in tests with a free-edge deflection rate of 0.01 in. per 1,000 lb of load. A limited amount of comparable data were obtained in tests in which a free-edge deflection rate of 0.02 in. was used. The comparison shown in Figure 30 related length of dowel embedment to the dowel looseness, developed by 600,000 cycles of repetitive loading, for each of the free-edge deflection rates mentioned. It is indicated that the deflection rate has little effect on the relation between length of dowel embedment and

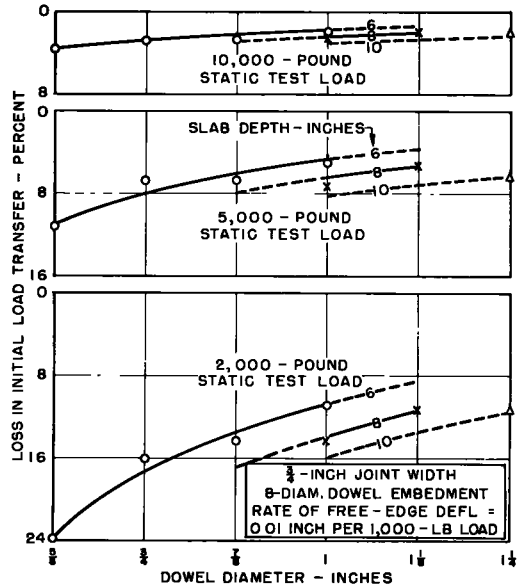

Figure 31. Relations between dowel diameter and loss in initial capacity to transfer load resulting from 600,000 cycles of a 10,000-lb load (base measurements obtained at first cycle).

ability of a dowel system, it is of interest to examine the data on loss in load transfer from such loading as determined from the strain measurements.

Figures 31-33 show the extent to which the initial load-transfer capacity of typical load-transfer systems deteriorated under 600,000 cycles of repetitive loading in which a 10,000-lb load was applied alternately on either side of the joint in each cycle.

The data in these graphs, expressed as percentages of the initial capacity of the particular joint system to transfer load, were taken from relations such as those in Figure 8. They have been arranged in the three graphs to show how the three design variables of dowel diameter, length of dowel embedment, and width of joint opening affect the loss in load-transfer capacity caused by repetitive loading. In each case, observed values are for static test loads of 2,000, 5,000, and 10,000 lb. The effect of any structural deterioration that develops is always most readily apparent under the 2,000-lb static test load.

Referring to Figure 31, the data indicate that as the diameter and correspond-

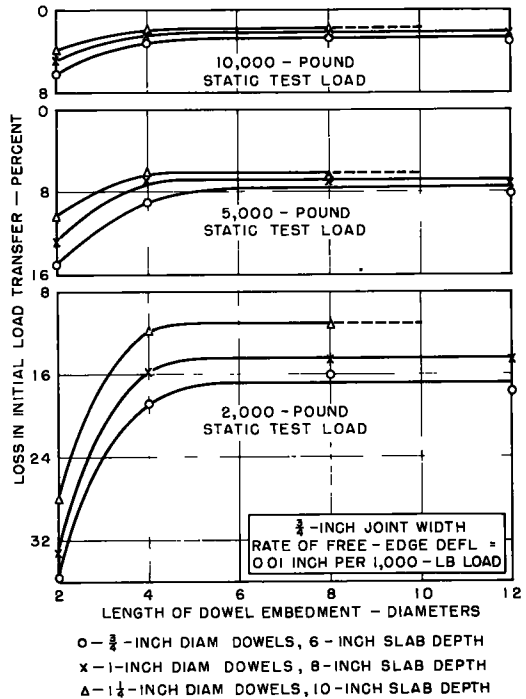

Figure 32. Relations between length of dowel embedment and loss in initial capacity to transfer load resulting from 600,000 cycles of a 10,000-lb load (base measurements obtained at first cycle).

ing bearing area of the dowel is increased, there is a marked improvement in the degree to which the initial capacity to transfer load is preserved during repetitive loading. The important influence of unit pressure in the dowel seat is emphasized by the data relating to dowel diameter.

In Figure 32 the effects of varying the length of dowel embedment are shown. Although the point at which curvature begins in these relations is not precisely established by the data, it is indicated that where the embedment length is 8-dowel diameters or more there is no effect on the loss of initial load-transfer capacity. Where the embedment length is 4-dowel diameters, there is little effect for the 1-in. and 1 1/4-in. diameter dowels; while for an embedment length of 2-dowel diameters, there is a marked effect with all three dowel diameters. Thus, so far as losses of load-transfer capacity under repetitive loading are concerned, it is indicated that other design considerations will probably determine the length of dowel embedment.

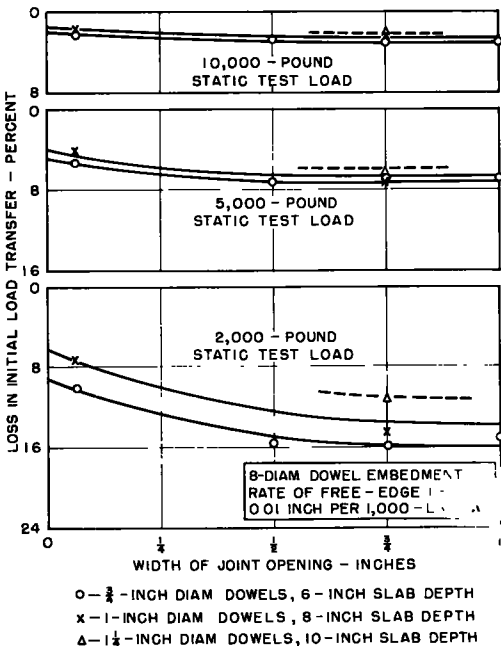

Figure 33. Relations between width of joint opening and loss in initial capacity to transfer load resulting from 600,000 cycles of a 10,000-lb load (base measurements obtained at first cycle).

In Figure 33, the data are arranged to show the effect of varying the width of joint opening on the losses of the initial load-transfer capacity which were caused by the 600,000 cycles of repetitive loading. It is indicated that as the width of opening is increased from $\frac{1}{16}$ to 1 in. there is an increase in the magnitude of the loss. It is indicated also that the rate diminishes rapidly with increase in width of joint opening. The data show one of the reasons why repeated loading would tend to cause less impairment of initial load-transfer efficiency in a contraction joint than would the same loading applied to a similarly doweled expansion joint.

As mentioned earlier in this discussion of the effects of repetitive loading on load transfer, it is possible to relate data from the deflection measurements with those obtained from the strain measurements. In Figure 34 the data from each type of measurement after 600,000 cycles with a 10,000-lb test load are compared. The increases in dowel looseness caused by the repetitive loading were determined from the relative deflection data, whereas the losses in initial load-transfer values were obtained from strain measurements. The computed relation was developed with Eq. 2 as described in the discussion of Figure 23, the dowel looseness caused by the repetitive loading being substituted for initial looseness.

It may be concluded from Figure 34 that there is an excellent correlation between the indications of the deflection data and those based on strain measurements on this important subject of the effects of repetitive loading on load transfer.

SOME DOWEL-STRESS DATA OBTAINED

Bradbury (3) and later Friberg (4) analyzed on the basis of theory the pressure, shear, and bending moment distributions developed in a steel dowel bar embedded in concrete, crossing an open joint, and acted upon by a load applied on one side of the joint. Recent experimental studies (9) have tended to verify the general validity of the earlier analyses.

When the present investigation was planned, no scheduled measurements of strains in the dowels or in the surrounding concrete were included. The measurement of strain either in the dowel or in the concrete, by the means presently available, usually involves the introduction of some disturbing modification in the materials or in the bearing of the dowels on the concrete that alters to some degree the basic condition

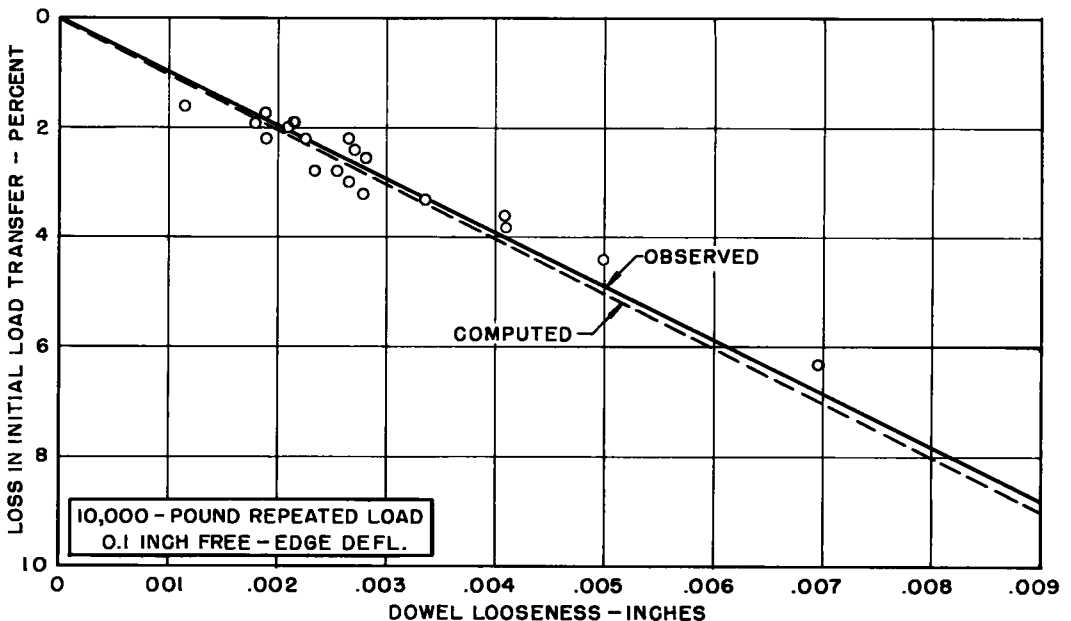

Figure 34. Relation between dowel looseness and loss in initial capacity to transfer load, after 600,000 cycles of a 10,000-lb load.

being tested. It was for this reason that strain measurements at critical locations in the dowels or in the surrounding concrete were omitted from the scheduled measurements. However, a limited amount of strain data were obtained in specimens having a width of joint opening of $\frac{1}{2}$ in. or greater by means of resistance type gages cemented to the dowel in the joint opening where no bearing contact was involved. It is recognized that these gages did not measure strains at the points of maximum bending moment. The data are of interest and some value, however, and are included in this report.

The strain gages used were SR-4, type A-7, with an effective gage length of $\frac{1}{4}$ in. They were bonded to the dowels along the upper element of the cylindrical dowel surface after the specimens were in place in the testing machine. The gages were used on each of the four dowels of a given specimen. In most cases the gage was so positioned that the center of its gage length was $\frac{5}{32}$ in. from the vertical face of the concrete in which the dowel was embedded. A gage in this position provides two strain values during a given loading cycle: one value as the load is applied on that half of the specimen nearest the gage position, and a second value as the load is applied on the opposite half of the specimen.

Theory indicates that with a dowel installation of usual dimensions a vertical force applied outside of the encasing concrete should develop the maximum bending moment in the dowel at a point within the concrete a short distance back from the joint face. As mentioned earlier it would have been desirable to have had a strain gage at this point, but its presence would have affected other conditions more important in the current investigation. In the graphs and discussion which follow, measured strains have been converted to stress values using modulus of elasticity values determined by tests.

Figure 35 shows load-stress data obtained with a specimen having $\frac{3}{4}$ -in. diameter dowels and a $\frac{3}{4}$ -in. width of joint opening, when tested with a free-edge deflection rate of 0.01 in. per 1,000 lb of applied load and before there had been any repetitive loading. The diagram shows also the details of the loading and strain gage positions with respect to the dowels.

The data in Figure 35 are typical of those obtained in all of the dowel systems tested in a number of respects, as follows:

1. The load-dowel stress relations are essentially linear within the load range of 2,000 to 10,000 lb. Departures from linearity at the lesser loads are believed to be due to initial adjustments in the seating of the dowels in their sockets.
2. The stresses in the two dowels nearest the loaded area are greater than those in the dowels farther from the load, indicating greater load transfer by these units as would be expected.
3. Within the joint opening the maximum stress in the dowel is found at the face of the loaded joint edge.
4. The point on the dowel within the joint opening at which the bending moment changes from positive to negative—the point of inflection of the elastic curve—was not found at the center of the joint width under the conditions of these tests. It will be shown later that the location of this point of inflection was found to vary with the physical dimensions of the dowels, the width of the joint opening, and with other conditions.

Although the stress values as determined from measured strains were not the maximum or critical values, they have been used in comparative studies of possible trends

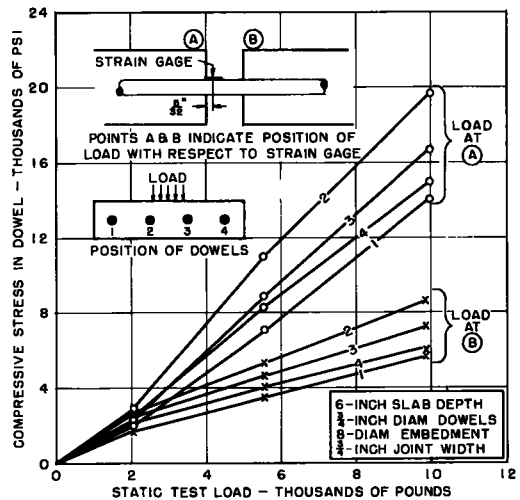

Figure 35. Example of relations between load applied at indicated joint edges and stress in dowels at indicated gage point before the application of repetitive loading.

that might apply to the design variables of dowel diameter, length of dowel embedment, and width of joint opening.

A procedure was adopted which is believed to provide the best comparative data for the purpose. Essentially it consists of relating average values of dowel stress to average values of dowel shear in the manner shown in Figure 36. In the example, the relation between the average shearing force per dowel and the average compressive stress in the dowel is shown for loads applied on either side of the joint opening. The relations are linear, so for each the slope is constant. The stress value per 1,000 lb of shear force is shown as 14,700 psi with the load at point A, and 5,100 psi for the load at point B.

In Figure 37 are diagrams representing joint widths of $\frac{1}{2}$, $\frac{3}{4}$, and 1 in., the diagram on the right being really a composite of three cases, one for each joint width. Average stress values, determined in Figure 36, have been plotted in Figure 37 as ordinates at distances from the joint faces corresponding to the respective points of strain measurement. The two points representing a given test

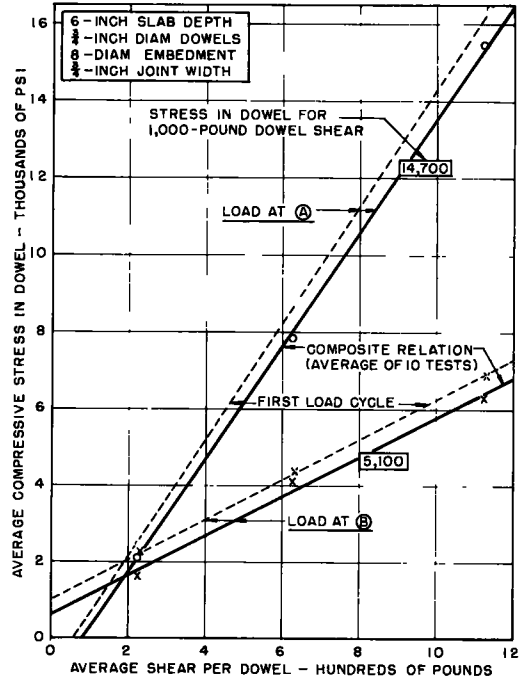

Figure 36. Example of relations between average shear per dowel and average stress per dowel at gage point indicated in Figure 35.

specimen have been connected with a straight line which has been extended to meet the vertical lines representing the respective joint faces. These two points of intersection then indicate an estimated dowel-stress value at each joint face for a shear of 1,000 lb. The values for the specimen used in Figure 36 are shown as solid circles, whereas the open circles are values obtained in the same manner for other specimens. The values of estimated stress in the dowels at the face of the joint on the side bearing the load are those used in the following comparisons of the various dowel systems.

The diagrams of Figure 37 show that within the joint opening the greatest stress occurs in the dowel at its point of entry into the concrete on the loaded side of the joint. This would be expected. Theory indicates that the stress should continue to increase in magnitude, rising to a maximum at some point a short distance from the joint face within the concrete.

Within the joint opening, the diagrams show that the stress-compression in the top and tension in the bottom of the dowel-

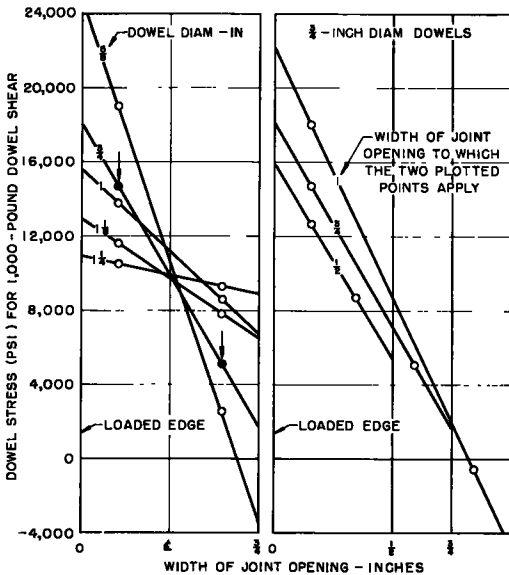

Figure 37. Examples of distribution of dowel stresses within the width of joint opening.

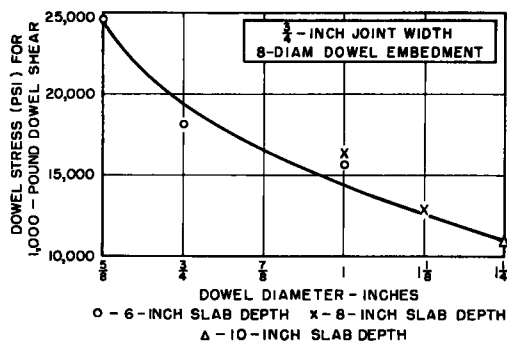

Figure 38. Relation between dowel diameter and stress in dowel at face of loaded joint edge.

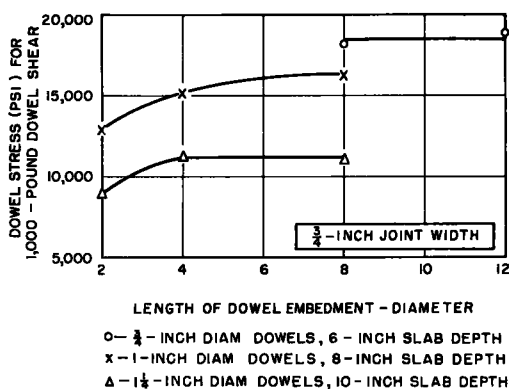

Figure 39. Relations between dowel embedment and stress in dowel at face of loaded joint edge.

are compared in Figure 38 for dowel diameters ranging from $\frac{5}{8}$ in. to $1\frac{1}{4}$ in. It is apparent that the relation expresses some inverse function of the dowel diameter. An empirical determination of the exponent required to produce a matching curve indicated its value to be 1.12. For the conditions of this test, it appears that increasing the diameter of the dowel from $\frac{5}{8}$ in. to $1\frac{1}{4}$ in. decreases the dowel stress at the joint face by about 50 percent. Had it been possible to compare values at the points of maximum stress, a somewhat greater reduction might have been shown.

The relations shown in Figure 39 indicate that dowels having an embedded length of 2 diameters are stressed appreciably less than those with greater embedded lengths. The 2-diameter length of embedment is apparently insufficient to develop the full bending resistance of the dowels. It will be observed that beyond a certain length of embedment there is no further increase in dowel stress, and from the data available these lengths seem to be in accord with the maximum useful lengths described earlier in the report.

As would be expected, the width of joint opening exerts an important influence on dowel stress, other conditions remain-

decreases from its maximum value at the face of the loaded slab, the rate of decrease varying with the diameter of the dowel and the width of joint opening. In only two cases does the sense of the stress change (from compression to tension in the top of the dowel) within the joint opening. These cases are the $\frac{5}{8}$ -in. diameter dowels in the $\frac{3}{4}$ -in. joint width and the $\frac{3}{4}$ -in. diameter dowels in the 1-in. joint width. In each of these cases, a tensile stress of small magnitude is indicated at the face of the unloaded slab.

It is evident that the point of inflection in the elastic curve of the dowel depends upon the flexibility of the joint system; and, for the conditions of these tests, only in the case of the two most flexible systems was the point of inflection within the joint opening. Some additional information on this point is given later in the discussion of collateral tests.

COMPARISONS OF DOWEL STRESSES

In Figures 38-40 dowel-stress values at the face of the slab end on the loaded side of the joint, determined in the manner just described, are used to show the influence on dowel stress of the three design variables: dowel diameter, length of dowel embedment, and width of joint opening.

With a $\frac{3}{4}$ -in. joint opening, an 8-diameter length of dowel embedment, and a dowel shear of 1,000 lb, dowel stresses

are compared in Figure 38 for dowel diameters ranging from $\frac{5}{8}$ in. to $1\frac{1}{4}$ in. It is apparent that the relation expresses some inverse function of the dowel diameter. An empirical determination of the exponent required to produce a matching curve indicated its value to be 1.12. For the conditions of this test, it appears that increasing the diameter of the dowel from $\frac{5}{8}$ in. to $1\frac{1}{4}$ in. decreases the dowel stress at the joint face by about 50 percent. Had it been possible to compare values at the points of maximum stress, a somewhat greater reduction might have been shown.

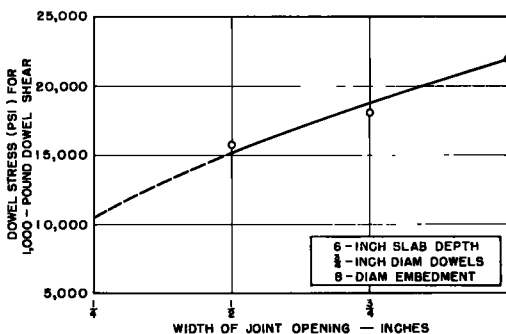

Figure 40. Relation between width of joint opening and stress in dowel at face of loaded joint edge.

ing constant. In Figure 40 this effect is shown for a $\frac{3}{4}$ -in. diameter dowel with an 8-diameter length of embedment. For these conditions a reduction in the width of joint opening from 1 in. to $\frac{1}{2}$ in. reduced the dowel stresses more than 30 percent. These data emphasize the difference in severity of loading conditions imposed on dowels installed in expansion joints, as contrasted with similar units in contraction joints, and explain the generally better service performance of the latter.

It would be useful to know the magnitude of the maximum stresses which existed in the dowels during the repetitive loading program. For the reasons stated earlier these maximum values were not obtained. The estimated values at the joint face on the load-
ed side, while less than the true maxima, are of interest however. The highest individual values observed during the repetitive loading program for the several dowel diameters were as follows:

<u>Dowel Diameter, in.</u>	<u>Dowel Stress, psi</u>
$\frac{5}{8}$	27,200
$\frac{3}{4}$	24,100
1	20,400
$1\frac{1}{8}$	15,500
$1\frac{1}{4}$	13,700

Each value shown is the average of ten measurements made during the application of 600,000 cycles of the 10,000-lb load.

During the repetitive loading program, the four $\frac{3}{4}$ -in. diameter dowels in the pilot-specimen were subjected to 2 million cycles during which the average maximum stress within the joint opening on the most highly stressed dowel was 21,600 psi.

In another case, a specimen containing four $1\frac{1}{4}$ -in. diameter dowels was subjected to 600,000 repetitions of the 10,000-lb load cycle during which the average maximum stress on the most highly stressed dowel was 13,700 psi. This was followed by 500,000 cycles with a 15,000-lb load which developed a dowel stress of 18,600 psi.

There was no apparent damage to the dowels as a result of the preceding tests. In only one special test did a dowel failure occur. This case is described later.

Figure 41 shows the oscillograph traces from strain gages mounted $\frac{3}{32}$ in. from the joint face on each of the four dowels in tests of two specimens. In the record pertaining to the $\frac{3}{4}$ -in. diameter dowels and the 1-in. width of joint opening, it is evident that in one case there was an actual stress reversal at the gage position as the load was changed from one side of the joint to the other. This is indicated in the upper trace by the fact that it crosses the horizontal base line from a high compressive strain (movement above the base line) to a small tensile strain (movement below the base line). Two of the other gages showed no strain, while the fourth gage showed a slight compressive strain during this half of the cycle.

In the case of the $1\frac{1}{4}$ -in. diameter dowels and the $\frac{3}{4}$ -in. width of joint opening, the indicated compressive strains are of lesser magnitudes than those of the $\frac{3}{4}$ -in. dowels; unlike the latter, they are of very nearly equal magnitudes during both halves of the loading cycle.

The small vibrations indicated by that part of the trace which represents the full application of the load are caused by a slight elastic vibration set up in the loading lever-dead-weight system as the lift-rod mechanism releases the load. Had the test been made at a higher frequency of load application, this effect would have become more pronounced unless some provision for damping were added to the system.

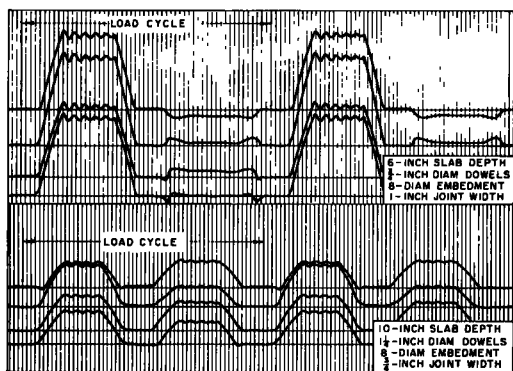

Figure 41. Oscillograms of strain in individual dowels for a 10,000-lb load.

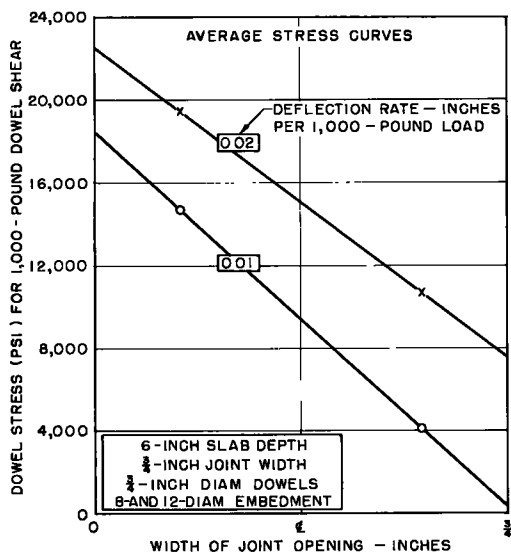

Figure 42. Effect of deflection rate on dowel stress.

COLLATERAL STUDIES

In conjunction with the research program that has been described, a considerable amount of data of interest and value was obtained during the course of a number of collateral studies that were made. These data will be discussed under appropriate headings in the paragraphs which follow.

Dowel Performance Related to Pavement Deflection

At several places in the report, mention has been made that six of the dowel systems were tested at a free joint-edge deflection rate of 0.02 in. per 1,000 lb of applied load (or twice the deflection rate adopted for the primary program). This study was made on systems of $\frac{3}{4}$ -in. diameter dowels embedded in slabs of 6-in. depth with a $\frac{3}{4}$ -in. width of joint opening and various lengths of embedment. From the comparisons afforded by these data, it

was found that the following conditions prevailed:

1. The percentage of load transferred was higher at the greater of the two deflection rates.
2. Values of the dowel deflection index (the deflection per 1,000 lb of dowel shear) were in most cases slightly but only slightly higher for the greater of the two deflection rates.
3. Tests at both deflection rates indicated the same maximum useful lengths of dowel embedment.
4. For the same repetitive load conditions, tests at the greater rate of joint-edge deflection developed greater dowel looseness.
5. As shown in Figure 42, values of dowel stress per 1,000 lb of dowel shear at the face of the loaded slab end averaged 21.5 percent higher for specimens tested at the greater of the two deflection rates. It is also indicated by this graph that as the deflection rate is decreased, the point of inflection on the dowel-stress distribution curve tends to move toward the center of the joint opening.

Comparison of Two and Four Active Dowels

In about one-half of the specimens tested, the outer dowels, or the dowels nearest the two sides of the specimens, were sawed through after completion of the scheduled test to provide some comparative data on the performance of 2- and 4-dowel systems.

It was found that among the systems tested the amount of load transferred by the two central dowels ranged from 97 to 99 percent of that transferred by four dowels. Thus it seems reasonable to infer that, other conditions being equal, the 4-dowel systems used in this investigation will transfer about the same proportion

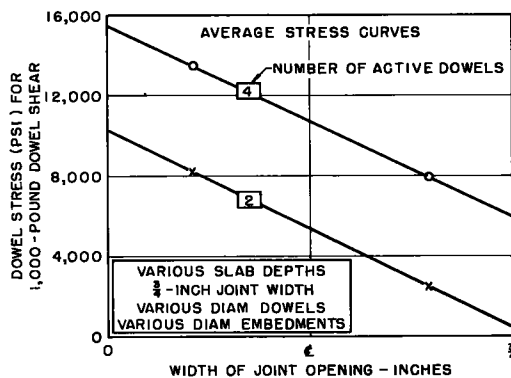

Figure 43. Effect of number of active dowels on dowel stress.

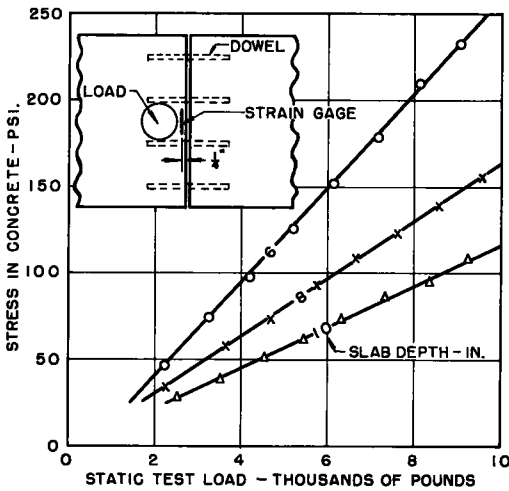

Figure 44. Typical relations between applied load and stress in concrete along the joint edge. (Each value is the average of ten observations.)

about 300 psi with the 10,000-lb test load. Later when slabs of 8- and 10-in. depth were tested, it was decided to maintain the same length of bearing throughout.

For the constant test load and rate of free-edge deflection, the effect was to reduce the bending stress in the concrete as the slab depth was increased approximately as the reciprocal of the depth squared. Figure 44 shows the position of the strain gage with respect to the area of load application as well as typical data obtained with specimens of the three thicknesses. The gage, cemented to the concrete, was the SR-4, type A-9, with an effective length of 6 in. It is apparent for the conditions of the test that the behavior of the concrete was elastic.

Concrete Bearing Stresses

Compressive stresses in the concrete in the vicinity of the dowels exert an important influence on the structural performance of load-transfer systems. In the case of the conventional round steel dowel, it has long been recognized that the compressive stresses above and below the dowel may be critically high. Marcus (10) has published experimental data which indicate bearing stresses under dowels, the magnitude of which was more than twice the compressive strength of the concrete.

These stresses are a maximum at the face of the slab end and are concentrated immediately above or below the dowel, depending upon the side of the joint on which the load is acting.

This investigation included no provision for a study of this important subject.

of the applied load as would the multi-dowel systems employed in the transverse joints of pavements in service.

The data afford two other interesting comparisons: First, with only two dowels active, the dowel-deflection index values tended in most cases to be slightly smaller than with four dowels active; and, second, as shown in Figure 43, values of dowel stress per 1,000 lb of dowel shear were appreciably reduced by severing the two outer dowels.

Flexural Stresses in Concrete

In the early planning of the tests it was considered desirable to develop some bending in the concrete along the joint edge to simulate more closely the conditions that would be found in the field. The early tests were made with a 6-in. depth of specimen, and by trial the length of bearing between the slab and the support beam was adjusted to develop a bending stress of

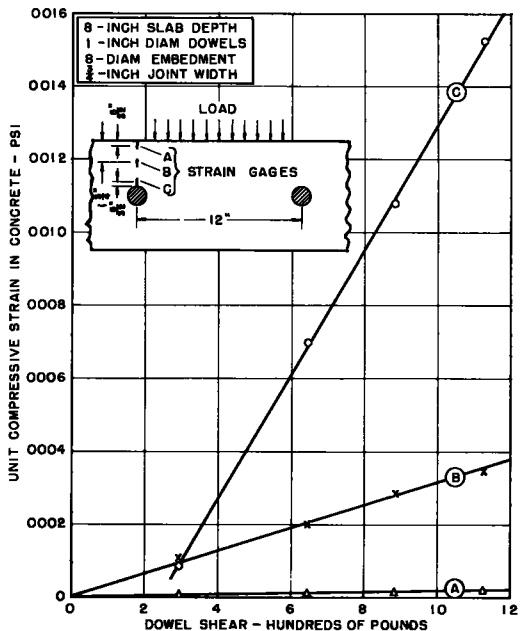

Figure 45. Dowel shear-concrete strain relations for the indicated points (A, B, C) at the face of the loaded joint edge. (Each value is the average of ten observations.)

However, on one specimen of 8-in. depth, an installation of three resistance strain gages with an effective length of $\frac{1}{4}$ in. was made in the manner shown in Figure 45. The load-strain relations obtained are those shown in the diagram. These are linear within the range of the test.

Values of concrete strain measured over so short a gage length may be affected to some extent by non-homogeneity of the concrete in the immediate vicinity of the gages. For this reason the data are expressed as measured strains. They are of considerable interest, however, as they indicate clearly the high intensity and localized effect of the pressure exerted by the dowel.

From the slopes of the load-strain relations of the three strain gages, values of concrete strain for 1,000 lb of dowel shear were obtained and shown in relation to the distance from the top of the dowel in Figure 46. This diagram indicates the highly localized nature of the deformation that occurs in the concrete and is in general accord with previously reported data.

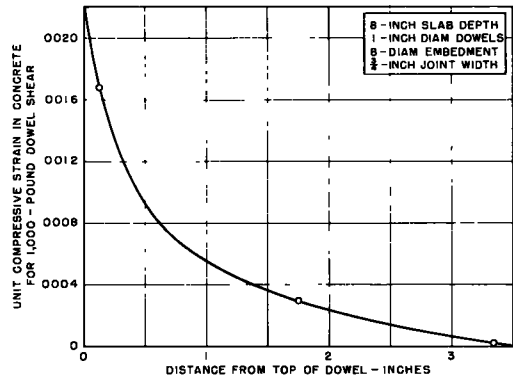

Figure 46. Variation in bearing strains in the concrete directly above the dowel, as measured at the face of the loaded joint edge.

Distribution of Dowel Stress

In the tests of the regular program only one strain gage was attached to a dowel because of the limited space within the joint openings. As explained earlier this led to an interpretation of a linear distribution of dowel stress between the joint faces. To obtain some data that would show whether or not this was a valid interpretation, the joint of one of the specimens was opened to a $3\frac{1}{4}$ -in. width after the completion of the prescribed tests. This gave sufficient space to permit the installation of five strain gages along the dowel. The specimen selected was 10 in. in depth and the dowels were $1\frac{1}{4}$ in. in diameter.

The location of the gages and the data obtained in this test are shown in Figure 47. The two curves show load-stress relations within the joint opening for loadings at points A and B on either side of the joint opening. From this diagram it may be concluded that within the limits of the test program the dowel-stress distribution across the joint opening is linear. It is of interest also that by opening the joint to $3\frac{1}{4}$ in., the flexibility of the system was increased to such an extent that the point of inflection or zero stress of these $1\frac{1}{4}$ -in. diameter dowels appeared within the joint opening.

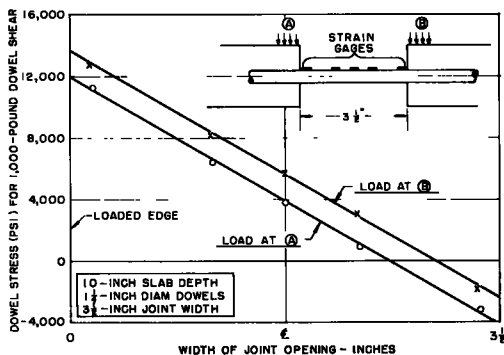

Figure 47. Distribution of dowel stresses within the width of a $3\frac{1}{2}$ -in. joint opening.

Modulus of Dowel Reaction

Extrapolating the dowel deflection data obtained with the various widths of joint opening (Fig. 14) beyond the $\frac{1}{16}$ -in. width to an assumed zero width, and using the mechanical properties of the steel and concrete as determined by test, values of the so-called modulus of dowel reaction were computed for the 6-in. slab depth and $\frac{3}{4}$ -in. diameter dowel, the 8-in. slab depth and 1-in. diameter dowel, and the 10-in. slab depth and $1\frac{1}{4}$ -in. diameter dowel. The values obtained were 3,026,000, 2,608,000, and 2,675,000 pci, respectively.

The modulus of dowel reaction or mod-

ulus of support is a measure of the support offered a dowel by the surrounding concrete as the dowel is deflected. It is analogous to the subgrade modulus used to express the support afforded the pavement slab by the subgrade, and like the latter it is expressed in pounds-per-cubic-inch units. It is usually denoted by K or G in the literature.

Fatigue Failure of Steel Dowels

It was stated earlier that in none of the tests of the regular program was there a failure of any of the steel dowels, in spite of the relatively high flexural stresses and the relatively large number of stress reversals in some of the tests. In one special test a fatigue failure of the dowels was produced, and both the procedure followed and the character of the failure are of some interest.

A specimen containing four $\frac{3}{4}$ -in. diameter dowels which had undergone 600,000 cycles with a 10,000-lb load was selected for further testing. During the regular testing, with four dowels active, the bending stresses at the joint face of the two central dowels averaged 18,800 and 22,800 psi, respectively.

The two outer dowels were severed and repetitive loading was resumed still using the 10,000-lb load. With but two dowels active the indicated stresses in the dowels increased to 24,300 and 28,200 psi, respectively. After 892,000 additional cycles of loading, failure occurred in both dowels. This happened outside of regular working hours and the sequence of events can only be surmised. The breaks were brittle fractures typical of fatigue failures. The dowel that was being stressed most highly failed on both sides of the joint opening; the other dowel failed on one side only.

Figure 48 is a photograph of the central piece of the dowel that broke on both sides of the joint. The two end views show the character of the fractures; the side view shows the location of the breaks with respect to the joint opening. The location of the breaks undoubtedly indicates the point of maximum moment in the dowel. In this case the fractures appear to be about $\frac{1}{2}$ -dowel diameter back from the joint face, within the concrete, on one side of the joint and approximately 1-dowel diameter on the other side of the joint. The location of break in the dowel which failed on one side of the joint opening only was within the concrete about $\frac{1}{2}$ -dowel diameter from the joint face.

From these failures it is apparent that the estimated dowel-stress values at the face of the joint (or slab end), arrived at by measurements of dowel strains within the joint opening, are probably appreciably less than the corresponding values at the point of maximum bending moment somewhere along the embedded length. In the case of the $\frac{3}{4}$ -in. diameter dowels, this point would appear to be not less than $\frac{1}{2}$ -dowel diameter from the beginning of the embedment.

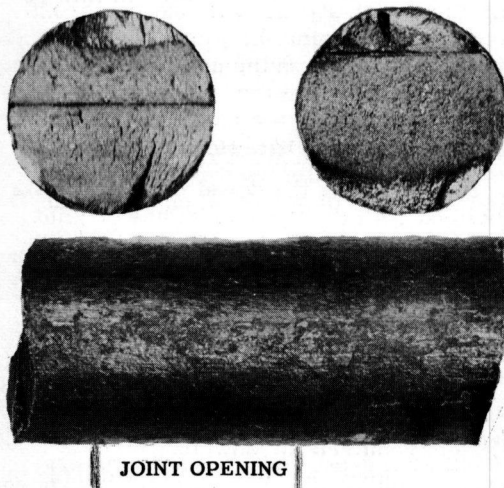

Figure 48. Fatigue failure of a $\frac{3}{4}$ -in. diameter dowel. The cross-section views at the top correspond to the left and right ends of the fractured dowel.

AREA OF FURTHER RESEARCH

The present test program has developed much important information on the performance of conventional round steel dowels under repetitional loading conditions which simulate closely those of actual service. This initial program could not include all of the variable factors involved in such service, however, and there are important questions that can be answered only by further tests. For example, the tests to date have all been made with high strength concrete in a dry condition. A limited program of additional tests is needed to relate the present data to those obtained with concrete of somewhat lower strength and containing entrained air. Also some tests should be made with concrete in a moist condition such as that found in most field service.

It would appear that this test procedure might be used effectively to develop much needed information on the perplexing question of load transfer by the fractured surfaces of plane of weakness joints in which there is no provision for mechanical load transfer.

In the program of tests just completed, tests were made with joint deflections which were representative of weak subgrade support. A limited series of additional tests should be made to relate the present data to other conditions of subgrade support, particularly those of a firm subgrade support.

Because of the high intensity of bearing pressure that is known to develop between the conventional dowel and the concrete, various expedients have been proposed for reducing this pressure. For example, the use of tubular dowels is a suggestion that has been made from time to time. The repetitive loading test procedure offers a means for evaluating this and other proposals of a generally similar nature.

Some load-transfer devices are made of malleable cast iron, a material that is susceptible to permanent deformation under repeated stressing. Some study of the behavior of malleable cast iron, when subjected to repetitive loading under conditions comparable to highway pavement service, should provide valuable information.

The method of test that has been developed and the machines for making the test provide a valuable facility for studying a number of other problems relating to the structural performance of joints.

SUMMARY

A new machine and method of test have been developed which provide a satisfactory means for studying, under repetitive loading, the effects of the several variables which influence the structural performance of dowel bars or other load-transfer devices used in the joints of concrete pavements. The conditions of the test approach closely those which are found when a heavy wheel load crosses a transverse joint of a pavement in service.

The test procedure makes possible a determination of the initial effectiveness of a load-transfer system as well as any loss in initial effectiveness which may develop as the result of a large number of applications of the loading cycle.

With this test procedure the principal effort thus far has been to determine the influence on the structural performance of round steel dowels of three important variables: dowel diameter, length of dowel embedment, and width of joint opening. For each of these variables an orderly relation has been established.

The following conclusions are based on an analysis of the data presented in this report.

1. A definite exponential relation exists between dowel diameter and load-transfer capacity, other conditions being constant.
2. A relation exists between slab depth and the dowel diameter required to transfer a given percentage of the applied load. This relation may be expressed as an approximate rule for minimum dowel size, as follows: For round steel dowels at a 12-in. spacing in joint openings of $\frac{3}{4}$ -in. width or less, the dowel diameter in eighths of an inch should equal the slab depth in inches.
3. The length of dowel embedment necessary to develop maximum load transfer is not a constant function of dowel diameter as has sometimes been assumed. With a $\frac{3}{4}$ -in. dowel diameter, maximum load transfer requires an embedded length of about 8-dowel diameters. With larger dowels, such as the 1-in. and $1\frac{1}{4}$ -in. diameters now in common use, full-load transfer is obtained with a length of embedment of about 6 diameters, both initially and after many hundreds of thousands of cycles of repetitive loading. The use of shorter dowels in these larger diameters would, in many cases, result in an appreciable savings in the amount of steel required for dowels.
4. For a given dowel diameter and condition of loading, decreasing the width of joint opening decreases the bending stress in the dowel. It decreases also the dowel deflection and hence increases the percentage of load transferred, both initially and after extended repetitive loading. It is evident that a given load-transfer system may

be expected to give a much better structural performance in a contraction joint than in an expansion joint of $\frac{3}{4}$ -in. width or greater.

5. The condition of dowel looseness has an important effect on the structural performance of the dowel, since it can function at full efficiency only after this looseness is taken up by load deflection. This is true for both initial looseness and that which develops during the course of repetitive loading. Tests which do not include repetitive loading and complete stress reversal provide no information on this important condition and no measure of its effects.

6. The application of extended repetitive loading decreases the initial ability of a given system to transfer load. Under equal conditions, the amount of this loss varies considerably as dowel diameter, length of dowel embedment, and width of joint opening are varied.

In the tests of the authorized program as described in this report, much important information was obtained on the structural performance of round steel dowels under repetitive loading. To complete the research, additional tests are needed. Recommendations as to the nature and extent of these tests are included in the report.

REFERENCES

1. Westergaard, H. M., "Spacing of Dowels." Proceedings of the Highway Research Board, 8th Annual Meeting, pp. 154-158 (1928).
2. Teller, L. W., and Sutherland, Earl C., "The Structural Design of Concrete Pavements." Public Roads, Vol. 16, Nos. 8, 9, and 10 (October, November, and December 1935); Vol. 17, Nos. 7 and 8 (September and October 1936); and Vol. 23, No. 8 (April-May-June 1943).
3. Bradbury, R. D., "Design of Joints in Concrete Pavements." Proceedings of the Highway Research Board, 12th Annual Meeting, pp. 105-136 (1932).
4. Friberg, Bengt F., "Design of Dowels in Transverse Joints of Concrete Pavements." Proceedings of the American Society of Civil Engineers, Vol. 64, No. 9, pp. 1809-1828 (November 1938). Also "Load and Deflection Characteristics of Dowels in Transverse Joints of Concrete Pavements." Proceedings of the Highway Research Board, 18th Annual Meeting, pp. 140-154 (1938).
5. Kushing, J. W., and Fremont, W. O., "Design of Load Transfer Joints in Concrete Pavements." Proceedings of the Highway Research Board, 20th Annual Meeting, pp. 481-493 (1940). Discussion by E. C. Sutherland, pp. 494-497.
6. University of Illinois, Engineering Experiment Station, "Experience in Illinois with Joints in Concrete Pavements." Bulletin Series No. 365, 260 pp. (1947).
7. Finney, E. A., and Fremont, W. O., "Progress Report on Load Deflection Tests Dealing with Length and Size of Dowels." Proceedings of the Highway Research Board, 27th Annual Meeting, pp. 52-63 (1947).
8. Journal of the American Concrete Institute, "Proposed Recommended Practice for Design of Concrete Pavements." Title No. 53-39, Vol. 28, No. 8, pp. 717-750 (February 1957).
9. Keeton, J. R., "Investigation of Load Transfer Characteristics of Dowels." Proceedings of the Highway Research Board, 35th Annual Meeting, pp. 147-151 (1956).
10. Marcus, Henri, "Load Carrying Capacity of Dowels at Transverse Pavement Joints." Proceedings of the American Concrete Institute, Vol. 48, pp. 169-184 (1952).

Appendix

Friberg Equations

Modulus of Dowel Reaction. From measurements of the deformation of the concrete, y_0 , at the face of the joint, under the bearing load, P , exerted by the dowel, a constant term, β , is obtained by utilizing the expression:

$$y_0 = \frac{P - \beta M_0}{2\beta^3 E_s I}$$

In which:

M_0 = the moment in the dowel at the face of the joint caused by the load, P , acting at a distance equal to half the width of the joint opening or $a/2$ (in. - lb);

E_s = the modulus of elasticity of the dowel steel (psi); and
 I = moment of inertia of the dowel section (in.⁴).

Having the value of β , the modulus of dowel reaction, K , may be obtained from the expression given by Friberg for the relative stiffness of the structure (dowel) and the mass (concrete), as follows:

$$\beta = \sqrt[4]{\frac{Kb}{4E_s I}}$$

The letter b represents the diameter of the dowel (in inches) and the other terms are as previously defined. The modulus of dowel reaction is expressed in pounds-per-cubic-inch units.

Dowel Deflection. The deflection of a dowel crossing a joint may be determined from the following equation:

$$\Delta = \frac{P}{2E_s I} \left(\frac{1 + (1 + \beta a)^2}{\beta^3} + \frac{a^3}{6} \right)$$

In which:

Δ = the difference in deflection of the loaded and unloaded sides of the joint with the dowel in full bearing on the concrete (in inches). The other terms are as previously defined.

Westergaard Equations

Slab Deflection. The deflection of a free slab edge and corner may be determined from the following equations:

$$z_e = \frac{0.433 P}{k l^2}$$

$$z_c = \left(1.1 - 0.88 \frac{a_1}{l} \right) \frac{P}{k l^2}$$

In which:

z_e and z_c = maximum deflection for edge and corner loadings, respectively (in inches);

P = applied load (pounds);

k = modulus of subgrade reaction (pci); and

a_1 = a dimension, measured along the bisector of the corner angle in the case of corner loading and equal to the diameter of the loaded area, a , multiplied by $\sqrt{2}$.

The dimension, l , termed the radius of relative stiffness, measured in inches, may be determined from the following expression:

$$l = \sqrt[4]{\frac{E_c h^3}{12(1 - \mu^2) k}}$$

In which:

E_c = modulus of elasticity of the concrete (psi),

h = depth of the slab (inches), and

μ = Poisson's ratio for concrete.

Discussion

BENGT F. FRIBERG, Consulting Engineer, St. Louis, Missouri—The report, covering extensive and painstaking tests on doweled joints, fills a gap in joint design which has existed for many years. Thanks to the careful and comprehensive research, doweled joints can be designed with much greater assurance of continued performance than has been possible heretofore. The researchers deserve high compliment for the ingenious testing arrangement which permitted tests made in the laboratory to simulate closely conditions observed in the field.

No previous information has been available, either on magnitude of voids around dowels resulting from dowel coatings and construction conditions, or on the effects of repeated loading of dowels. As illustrated in Figure 5, the effect of repeated loadings is entirely analogous to dowel looseness; for the range from 5,000- to 10,000-lb wheel load the rate of dowel deflection remains linear and, surprisingly, in that range of loading, the rate of deflection even after 2,000,000 loadings was the same as for initial loading. This means that once the looseness has been taken up during the early stage of each loading the effective dowel bearing and bending in the later state occur in substantially unchanged manner even after very many load repetitions. This would indicate slow frictional wear (or polishing), rather than funneling, around the dowel. Smooth dowel surfaces appear to be desirable.

In earlier theoretical and experimental dowel investigations, the reactive vertical pressure against the dowel has been assumed to be proportionate to the deflection of the dowel at any point in the embedment, without regard to dowel looseness. A comparison between the experimental data and theoretical analyses is given below for $\frac{3}{4}$ -, 1-, and $1\frac{1}{4}$ -in. dowels crossing a $\frac{3}{4}$ -in. joint under initial application and after 600,000 cycles of a 10,000-lb wheel on a pavement edge at 0.01 in. per kip deflection rate. Pavement depths from 6 to 10 in. appear to be a substantial influence, especially with respect to looseness developed by repeated loads as shown in Figure 27, and rate of deflection under load as shown in Figure 11, the thinner slabs showing lower values in each case; this is believed due to experimental conditions of support and deflection observations, which might favor thin slabs. Trends indicated for thicker slabs, with values for $\frac{3}{4}$ -in. dowels in 6-in. slabs increased correspondingly, are possibly more representative for field conditions. Initial looseness values were observed with good correlations according to Figure 22.

The rates of dowel deflection (after take up of looseness) are obtained from Figure 11. Adjusted for possible experimental influence of slab depth, the approximate rates of dowel deflection probably would not exceed 0.004, 0.0025, and 0.0017 in. per 1,000-lb dowel shear for the $\frac{3}{4}$ -, 1-, and $1\frac{1}{4}$ -in. single dowels. The following looseness dimensions and dowel deflection rates, in inches, are indicated to be representative:

	<u>Dowel Size</u>		
	$\frac{3}{4}$ in.	1 in.	$1\frac{1}{4}$ in.
Initial looseness, Figure 22	0.0035	0.0025	0.0025
Additional looseness for 600,000 cycles, Figure 27	0.0035	0.0025	0.0020
Rate of deflection per 1,000-lb shear, Figure 11	0.004	0.0025	0.0017

Based on the above dowel deflection values, Figure 49 has been drawn to show the approximate experimental relationships between dowel shear and total dowel deflection across a $\frac{3}{4}$ -in. joint for $\frac{3}{4}$ -, 1-, and $1\frac{1}{4}$ -in. dowels. In the three graphs of Figure 49 comparative lines of dowel deflection have been drawn, as computed by the formula for relative deflection in the appendix without consideration of looseness for different assumed values of modulus of dowel reaction K.

The theoretical deflection line which is parallel with the experimental deflection rate line indicates the applicable modulus of dowel reaction representing dowel action within the concrete. As shown in the graphs, the approximate K values are from 2.2

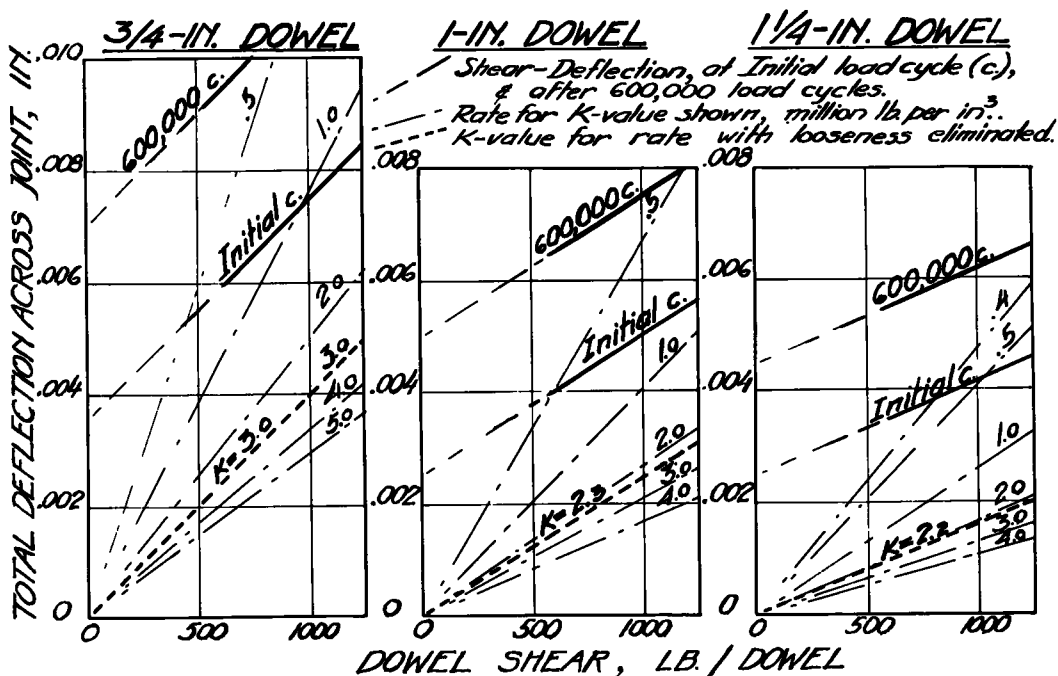

Figure 49. Representative relation of dowel shear and deflection from the tests of 3/4-, 1-, and 1 1/4-in. dowels, for 10,000-lb load and 0.01 in. per kip pavement deflection rate. Modulus of dowel reaction shown for rates of deflection as computed.

to 3.0 million pci for 1 1/4 to 3/4 in. dowels; those compare with values of 2.6 to 3.0 million pci given in the paper. The relative deflection consists of deflections at the two faces of the concrete, dowel slope deflection across the joint, and a minor increment of dowel cantilever deflection within the joint space. The relative magnitudes of the major increments of deflection, and corresponding dowel bearing pressures, are:

Dowel size, in.	3/4	1	1 1/4
K-value, 10 ⁶ pci	3.0	2.3	2.2
<u>Distribution of cross joint deflection</u>			
Each of two faces, percent	32.5	36.5	38.5
Slope across joint, percent	33	26	28.5
Dowel cantilever, percent	2	1.0	0.5
<u>Rate of cross joint deflection,</u>			
per 1,000 lb	0.004 in.	0.0025 in.	0.0017 in.
<u>Dowel face deflection, per 1,000 lb</u>			
	0.0013 in.	0.00091 in.	0.00066 in.
<u>Bearing pressure of dowel shear,</u>			
per 1,000 lb	3,900 psi	2,100 psi	1,450 psi

For the 10,000-lb wheel load the shear on the inside dowels would approximate 1,200 lb. Apparently the concrete around 3/4-in. dowels sustained high local bearing pressures for at least 2,000,000 cycles without failure. The maximum moment in the 3/4-in. dowels due to shear, computed per ref. (4), would occur 0.5 in. from the face of the concrete and equal 700 in. lb for 1,200 lb. shear. An additional dowel moment due to "tilt," as explained later in this discussion, approximating 300 in. lb could occur coincident with the maximum moment due to shear. Even though load deflections between the dowel and the concrete are small in comparison with the looseness dimensions, the theoretical moments and stresses appear to be compatible with the experimental evidence.

Crossjoint deflections at maximum wheel load determine the load transfer efficiency of a dowel system. With 1,200 to 1,300-lb shear on the inside dowel for a 10,000-lb wheel load, the corresponding theoretical deflection computed in accordance with formula in the appendix, as drawn in Figure 49, should be based on K-values of about 0.7, 0.5, and 0.4 million pci for $\frac{3}{4}$ -, 1-, and $1\frac{1}{4}$ -in. dowels. However, with data on looseness available from this research, adjustment of the formula shown in the appendix by introducing a deflection term for looseness is warranted, as follows:

$$\Delta = d_0 + \frac{P}{2E_s I} \left(\frac{1 + (1 + \beta a)^2}{\beta^3} + \frac{a^3}{6} \right)$$

in which d_0 is the looseness, independent of load and joint width in the form shown, with different values for various dowel sizes and pavement ages. Dowel looseness is not entirely independent of either joint width as shown in Figure 29, or pavement load-deflection as shown in Figure 30, but the observed values appear to be well correlated with dowel size for wide joints.

Without looseness the percentage of load transfer is expressed by Eq. 1 of the paper. With dowel looseness d_0 existing, the loaded pavement must deflect an equivalent amount before load transfer becomes proportionate to the remaining wheel load at a linear rate of dowel deflection, as illustrated by the tests above 5,000-lb load. The percentage of load transfer P_d of the wheel load W is expressed by the following equation:

$$P_d = \frac{1 - \frac{d_0}{W y_p}}{2 + \frac{y_d}{y_p}} 100 \quad (3)$$

in which y_d is the rate of deflection of the doweling system (having the same relation to single dowel deflection as the load on the most heavily loaded dowel, at the load, has to the total load transferred). In relation to ideal (no play) load transfer P_1 , Eq. 1, Eq. 3 takes the form

$$P_d = P_1 - \frac{d_0}{W y_p} P_1 \quad (4)$$

The loss in load transfer due to looseness, plotted in Figures 23 and 34, accordingly applies as percent of the ideal load transfer (not as percent of wheel load).

For a 10,000-lb wheel load after 600,000 cycles, and deflection characteristics as shown in Figure 49, the load transfer by the four-dowel system computed by Eq. 3 under assumption of 30, 29 and 28 percent of the shear on the most heavily loaded dowel, would give 43.9 percent, 45.9 percent, and 46.5 percent load transfer for the $\frac{3}{4}$ -, 1-, and $1\frac{1}{4}$ -in. dowel system, respectively. Comparative experimental values were: for $\frac{3}{4}$ -in. dowels per Figure 7, 44.6 percent; and for 1- and $1\frac{1}{4}$ -in. dowels per Figures 18 and 34 using Eq. 4, 45.5 percent and 46.3 percent, respectively. The high retained load transfer capacity after repeated loading is noteworthy.

The writer's dowel investigations (4) did not give attention to pavement deflection at the joint, that is, tilt of both slabs toward the joint, as a source of dowel stress. The effect of tilt, as illustrated in Figure 50, for load centered over the joint, is bending in the dowel equally on both sides of the joint with compression in the top of the dowel, and pressure between the dowel and the concrete above. Superimposed on these stresses are those due to shear in the dowel, additive compression in the dowel and against the concrete on the loaded side of the joint, but counteracting, or reversing the stresses due to tilt, on the side of the joint away from the load. For low rates of pavement deflection the stresses due to tilt would be small, but for high rates of pavement deflections, as used in the tests, the tilt stresses are of the same order of magnitude as stresses due to dowel shear.

Theoretical stresses due to tilt are easily ascertained in accordance with general formulæ given in ref. (4). For an angular change on each side of a joint, α moments arise in the dowel, symmetrical with respect to the joint and largest at the joint M_t ,

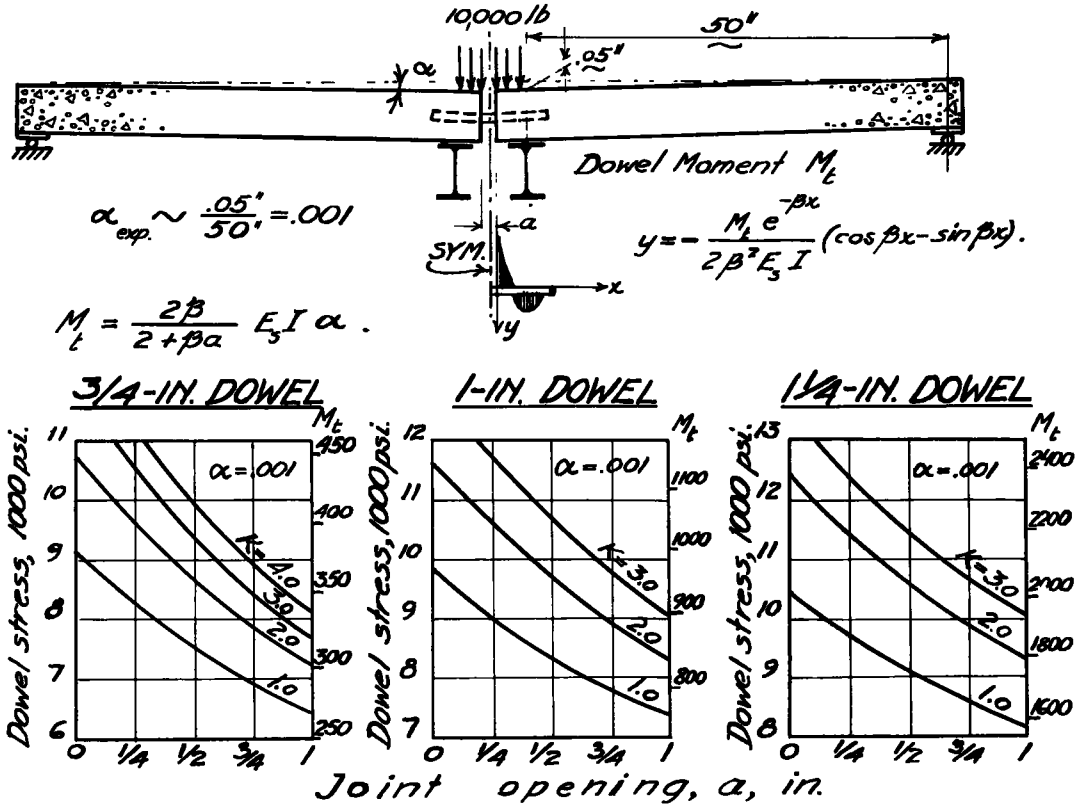

Figure 50. Bending of dowels due to pavement tilt for load at a joint, and tilt stresses in 3/4-, 1-, and 1 1/4-in. dowels crossing joints up to 1 in. wide, computed for 0.001 radian tilt on each side and different values of modulus of dowel reaction, K, shown in million pounds per cubic inch.

and diminishing on each side. The dowel deflections at any point in the concrete due to the tilt moment (Eq. 2 of Ref 4) would be:

$$y = -\frac{M_t \cdot e^{-\beta x}}{2\beta^2 E_s \cdot I} (\cos \beta x - \sin \beta x) \tag{5}$$

The angular change at the face of the concrete is obtained from Eq. 3 of ref. (4), and is:

$$\frac{dy}{dx}_{x=0} = \frac{M_t}{\beta E_s \cdot I}$$

The angular change in the dowel portion from the face of the concrete to the center of the joint is

$$\frac{M_t}{E_s \cdot I} \cdot \frac{a}{2}$$

The total angular change on each side, α , is accordingly:

$$\alpha = \frac{M_t}{E_s \cdot I} \left(\frac{1}{\beta} + \frac{a}{2} \right) \tag{6}$$

from which

$$M_t = \frac{2\beta E_s \cdot I}{2 + \beta a} \cdot \alpha \tag{7}$$

The corresponding deflection of the dowel in the concrete at the face of the joint, y_t , is obtained from Eq. 5:

$$y_t = \frac{2 a}{\beta (2 + \beta a)} \tag{8}$$

The maximum concrete bearing stress is $K \cdot y_t$.

Figure 50 shows, for $\frac{3}{4}$ -, 1-, and $1\frac{1}{4}$ -in. dowels across joints up to 1-in. wide, the tilt moment and bending stress for angular change of 0.001 radian on each side of a joint and for modulus of dowel reaction 1.0, 2.0, 3.0, and 4.0 million pci and without consideration of dowel looseness. The angular change shown in Figure 50 is about equal to the maximum average tilt in the tests. The dowel stress for 0.001 radian tilt at the $\frac{3}{4}$ -in. joint, in the $\frac{3}{4}$ -, 1-, and $1\frac{1}{4}$ -in. dowel in order, would be: for 2.0 million modulus, 7,900, 9,000, and 10,000 psi; for 3.0 million modulus, 8,500, 9,880, and 10,700 psi. The corresponding concrete bearing stresses would be: 780, 1,020, and 1,240 psi; 1,020, 1,350, and 1,650 psi. Dowel looseness affects tilt moments and stresses especially for short dowels, as indicated in Figure 39; however, for normal dowel lengths tilt would be less influenced by looseness than shear deflections and stresses. For tilt in the experimental $\frac{3}{4}$ -in. dowels an effective modulus of dowel reaction, looseness considered, of 2.0 million lb per in. is assumed.

Figure 51 shows how shear stresses combine with the tilt stresses in a $\frac{3}{4}$ -in. dowel across a $\frac{3}{4}$ -in. wide joint between slabs, tilted 0.001 radian on each side coincident with the assumed dowel shear is 1,000 lb and the modulus of dowel reaction 2,000,000 pci. The top graph shows stress due to tilt, the center graph stress due to shear, and the bottom graph the combined dowel stress. The shear in the dowel portion in the joint opening is constant; the change in observed dowel stress across the joint multiplied by the section modulus and divided by the joint width, gives directly the experimental shear in the dowel. In the bottom graph have been drawn also the stresses from strain gage readings in the joint according to Figures 34 and 42. The coincidence in slope between the theoretical and observed stresses in the joint is a measure of how

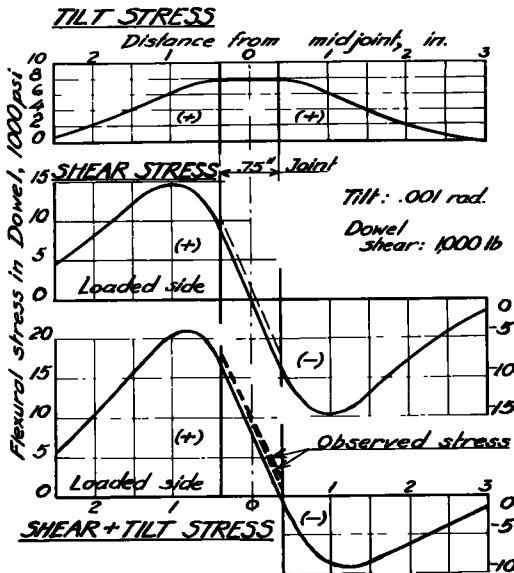

Figure 51. Combined stresses in a $\frac{3}{4}$ -in. dowel across a $\frac{3}{4}$ -in. joint because of pavement tilt and dowel shear, computed for 0.001 radian tilt, 1,000 lb dowel shear, and modulus of dowel reaction of two million pci. Comparative observed stresses shown.

close the dowel test shear was to 1,000 lb. The observed stresses are slightly higher than the computed stresses; that is a measure of modulus of dowel reaction somewhat higher than assumed in Figure 51, and of the slight error in assuming an inflection point for shear in the dowel at the middle of the joint opening, or, in other words, symmetrical tilt. As indicated by a dotted line in the center graph only a very small deviation in inflection point away from mid-joint would give excellent coincidence between theoretical and observed dowel stress. The agreement between theory and tests is very close.

The need for taking stresses due to tilt moment into account is easily seen in Figure 51. On the loaded side the $\frac{3}{4}$ -in. dowel stress is increased 45 percent above the bending stress due to shear alone; the concrete bearing stress is increased 780 psi above the 3,900 psi due to shear. On stiffer subgrade and in thick slabs tilting at a lesser rate than that used experimentally (which was the same for all slab thicknesses), the influence of tilt would be less; however, the experimentally used pavement deflection rate

would not be too different from some corner deflections observed in the field. Unloaded joints in the field are frequently warped up; tilt stresses will be relieved by wheel loads near such joint. But if subgrade support is lacking under level joints tilt stresses of the magnitude in the tests may well occur and should be considered in joint design.

The observed stresses in Figure 35, as well as other illustrations, are rationally explained when tilt stresses are considered. The observed stress change across the joint width are for most observations in close agreement with the theoretical dowel shear. The increase in dowel stress, Figure 42, is entirely due to the greater slab tilt and tilt stress in the dowel for increased rate of pavement deflection. With reference to Figure 43, the decrease in dowel stress per 1,000 lb of dowel shear for two dowels as compared to four dowel system is also explained by tilt stress change; for four dowels active a wheel load approaching 10,000 lb with about 0.001 radian pavement tilt was necessary to produce 1,000 lb dowel shear, corresponding to tilt stress in $\frac{3}{4}$ - to $1\frac{1}{4}$ -in. dowels from 8,000 to 11,000 psi in a $\frac{3}{4}$ -in. joint opening; for two dowels active a wheel load of about 5,000 lb is sufficient to give a dowel shear of 1,000 lb, and the pavement deflection at the joint, the tilt, and the tilt stress would be proportionally decreased. As seen in Figure 43, and represented by dowel stress at mid-joint, the tilt stress corresponding to two dowel shears of 1,000 lb each is one-half of that for four active dowels.

The research and report have added very greatly to the store of knowledge concerning the structural performance of pavement joint doweling. The research work could profitably be continued, to determine effects of joint movement and faulty dowel alignment as well as loading, to obtain data on variables of dowel looseness as related to construction practices, and to learn about mechanics of material failures at dowels for different concrete strengths, and at joints with other types of interlocks and dowels.

Raveling and spalling along joint edges are pertinent factors in long-time deterioration of concrete pavements. Tests of various joint designs and joint interlocks on the ingenious testing equipment for controlled laboratory conditions, under variously imposed conditions of dimensional variations, tying, restraints, sealing, infiltration, freezing, etc., could well be expected to clarify performance factors of vital importance to pavement durability, through longer lasting and maintenance free joints.

Noticeable economies could be possible by use of the results of the research in the large highway construction program immediately ahead. Shorter dowels than used heretofore are shown to be permissible, and would be particularly desirable for stainless surfaced dowels which may be specified increasingly, and with a high premium on weight saving. The research has given evidence of continued high efficiency of load transfer, much higher than that commonly considered in pavement design applied to corner loads on pavements with imperfect subgrade support, for which 20 percent load transfer and stress relief is assumed generally. Actual sustained load transfer of 40 percent could be assumed with four active dowels which may be representative for normal pavement corner construction. Insofar as pavement design is governed by corner stresses, corresponding design economies appear to be feasible.