

# Trends in Travel to the Central Business District by Residents of the Washington, D.C., Metropolitan Area, 1948 and 1955

JACOB SILVER,<sup>1</sup> Transportation Economist, Division of Highway Planning, Bureau of Public Roads

This paper evaluates the changes that took place between 1948 and 1955 in the relationship of the central business district to the metropolitan area. Many of the findings presented here, which are based on quantitative data, confirm the unsupported views of persons concerned with the changing urban structure.

Although the number of trips destined to the central business district increased during the 7-year period, the proportion of total area trips to the central area declined. Suburbanization, accompanied with development of commercial establishments, has had a definite impact upon the business center of the city. Although the central business district remained a major terminus for residents trips, it was less so in 1955 than in 1948.

● **CENTRAL** business districts in today's metropolitan areas are taking on new meaning in the urban structure. In the past 2 decades the urban population has increased at a very rapid rate, with a general tendency on the part of families to live farther from the central city. With this expansion has come a development of new outlying commercial and service facilities which, with an increased number of new employment centers outside the central business district (CBD), are now carrying on functions formerly associated with the central area.

What has been the impact of the growth of these functions upon the CBD and the travel to it? The need for information to answer this question has become increasingly important in order that planners and legislators may have a better understanding of the changing urban relationships in this very complex section of cities. From the data obtained from the 1948 and 1955 home-interview travel surveys<sup>2</sup> which were sponsored by the Regional Highway Planning Committee for metropolitan Washington, D. C. , in cooperation with the Bureau of Public Roads, an attempt has been made to measure this impact as it relates to travel.

## SUMMARY OF FINDINGS

The most important travel characteristic reflecting the change in the relative economic character of the CBD between 1948 and 1955 was the decreasing proportion of trips to the CBD in relation to total travel. The pattern in which the percentage of intra-area trips destined to the CBD decreased progressively with distance and varied with socioeconomic conditions and historical trends in a lateral direction around the CBD remained similar in both years. In 1955, however, residents of each of the geographical subdivisions studied made a smaller proportion of their intra-area trips to the CBD than in 1948. Although the CBD remained a land-use complex of major trip attraction, it was less an attractor of trips in 1955 than in 1948.

Of those residents who did make trips to the CBD, the more important changes in the geographical pattern of their distribution took place with distance from the central

---

<sup>1</sup> This paper was presented at the 38th Annual Meeting of the Highway Research Board, Washington, D. C. , January 1959.

<sup>2</sup> The procedures used in these studies are described in the "Manual of Procedures for Home Interview Traffic Study," which is available by purchase from the Public Administration Service, 1313 East 60th Street, Chicago, Ill.

area rather than with direction. Although there were fluctuations in the directional distribution of CBD trips, the pattern in 1955 remained approximately the same as in 1948. The pattern of distribution as related to distance indicated a more significant shift, however, as an increasing percentage of the CBD trips were made by individuals residing at greater distances from the central area. These changes followed a pattern related to the distribution of population and residential growth, and also to the increasing uniformity in the frequency of trips per dwelling unit.

As indicated by the number of trips for each purpose, the functions carried on within the central area were changing. The retail segment of the CBD became relatively less important as the number of trips for non-retail activity increased and those for shopping decreased.

This does not imply that shopping trips to the central area will decline until they become insignificant. The volume of shopping trips should increase if greater accessibility to the central area is provided and shopper convenience is improved. Nevertheless, by providing the same attracting forces outside the CBD that previously caused residents to make trips to the CBD, a greater choice in direction of movement has been given area residents.

Of those residents who were attracted to the central area for one purpose or another, the most notable change was the increasing use of the private automobile. The general increase in automobile ownership permitted a greater use of this mode of travel for all purposes for which trips would be attracted to the CBD. As automobile ownership increases in those subdivisions that were among the lowest in 1955, and as the number of trips to the CBD by individuals residing at greater distances from the CBD where transit service is less convenient increases, the use of the private automobile in traveling to the CBD should increase even more.

In Washington, D. C., as in other cities, many CBD functions have expanded into the fringe area surrounding the CBD because of increasing costs of land, rent, taxes, etc. As a result, many of the travel characteristics peculiar to the central area have become apparent in the fringe area. To obtain a more comprehensive picture of travel to the CBD, this area should be analyzed in future studies.

### SCOPE OF STUDY

The metropolitan area of Washington, D. C., included in the 1948 transportation study is shown in Figure 1. To develop travel data to the central area and to determine the relative effects of distance as well as direction upon a person's travel to the CBD, the study area was subdivided into rings and sectors. Sector divisions of the 1948 survey were used to indicate direction and 2-mile rings, as measured from the Zero Milestone,<sup>3</sup> were used to show distance. Together they make up what henceforth will be called ring-sectors, and all trip data were grouped into these subdivisions. Ring-sectors are comprised of a number of transportation zones grouped according to the distance from the CBD of each zone's 1948 centroid of population. Because of the location of the centroids of population and the irregular shapes of transportation zones, the stippled areas in Figure 1 tend to overlap the distance rings.

The area of the repeat study in 1955 was extended beyond the 1948 limits because of the growth in residential development. To have comparable data for a trend analysis, however, only those trips by persons residing within the 1948 area were used. This procedure did not bias the 1955 data to any great extent since the 1948 area included residents who made 92 percent of the trips within the 1955 cordon and 95 percent of the residents trips destined to the CBD.

The Washington CBD, as defined in this analysis, is shown in Figure 2. Trips to this area, included in the study, were average weekday trips related to the traveler's

---

<sup>3</sup> Although Zero Milestone was not the exact center of the CBD, it was chosen for use in this study because it had been employed in an earlier study "Travel to Commercial Centers of the Washington Metropolitan Area," by Gordon B. Sharpe, Highway Research Board Bulletin 79, 1953.

zone of residence, even though the trips may have originated elsewhere. Although the trip zone of origin would provide a truer picture of direction and distance of actual travel to the CBD, experience in sampling has shown that place of residence and distribution of population are more stable and reliable factors when determining travel characteristics, both for the purpose of estimating future travel patterns to the CBD and for comparing travel patterns in two or more cities.

The trip purposes studied were limited to three groups: work, shop, and other. The category of "other" included business, medical-dental, school, social, recreation, eat meal, change mode of travel, serve passenger, and home trips.

There were several reasons for this grouping of trip purposes: first, for the purposes of analysis, it was simpler; second, trips to work and to shop are the purposes most closely associated with trips to the CBD; and third, residents making trips for each of the reasons grouped in the "other" category made less than 20 percent of such trips to the CBD on an average weekday.

The modes of travel analyzed included automobile driver, automobile passenger, taxi passenger and mass-transit passenger. Trips by taxi and truck operators in the course of their daily work and all pedestrian travel were excluded. Pedestrian trips, however, must be kept in mind in any discussion of data concerning trips coming from within the first 2-mile ring.

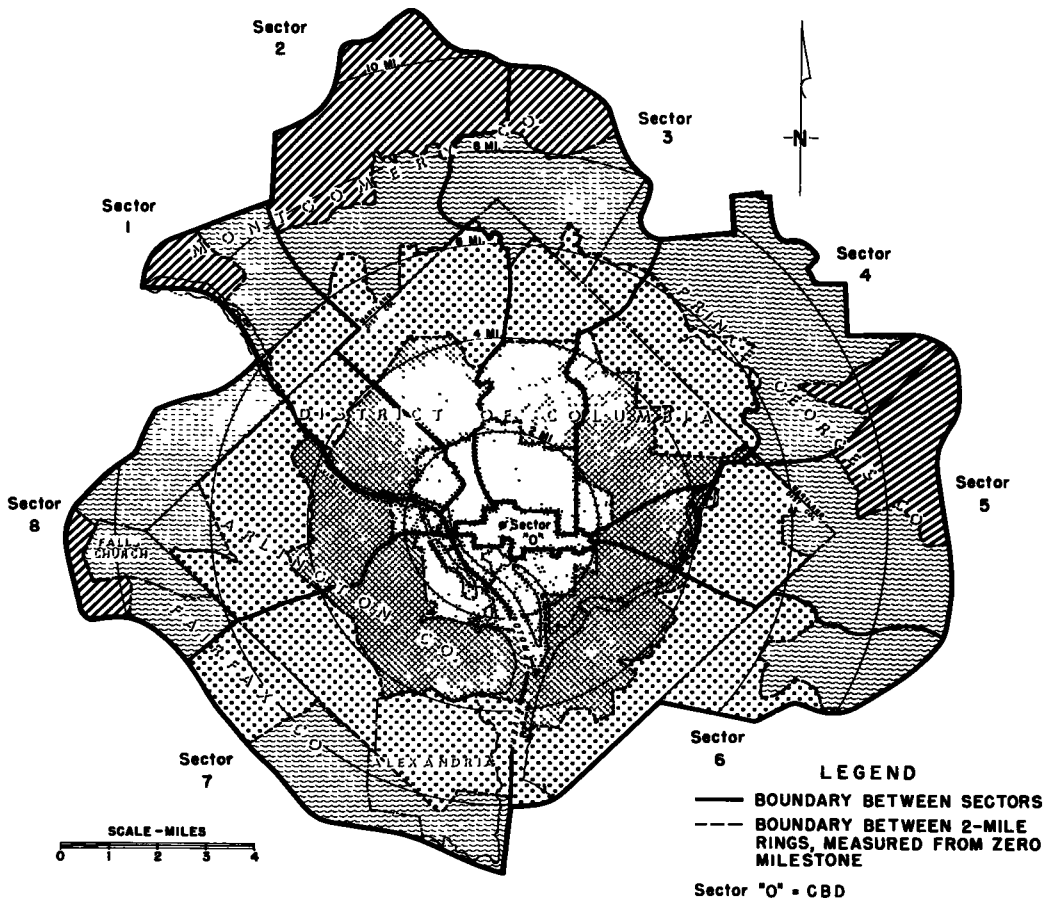

Figure 1. 1948 Washington, D.C. metropolitan transportation study area, by ring-sectors.

## CHARACTERISTICS OF STUDY AREA

Though there were changes within the Washington CBD, such as buildings demolished, parking facilities created, new office buildings erected, etc., the basic physical outline did not change greatly between 1948 and 1955, and it continued to have the commercial and employment functions associated with this complex type of land use. In addition, the CBD also houses many Federal Government activities, which are a major source of employment for area residents.

The number of persons employed in the CBD remained almost constant, increasing less than 2 percent between 1948 and 1955 (189,100 to 192,800 persons employed).<sup>4</sup> Employment opportunities, however, had increased outside the CBD at a greater rate than within. The proportion within the CBD decreased from 31 to 27 percent, or from a ratio of 1 job for every 6 persons to 1 for every 8 persons living in the area.

Retail sales within the CBD remained approximately the same, about \$367 million for each of the 2 years. This is not a true comparison, however, when considering the changed value of the dollar. It was found that prices in 1955 had increased generally by 11.4 percent over 1948. When adjusted by the Consumer Price Index for metropolitan Washington as published by the Bureau of Labor Statistics, 1955 retail sales amounted to \$325 million, or a relative loss of 11 percent, as measured in 1948 dollars. Moreover, even though retail sales for the metropolitan area increased, the proportion of these sales made within the CBD, on a constant dollar basis, decreased from 26 to 19 percent. Since the close of World War II, population growth in the Washington, D. C., area has followed the general trend of most large metropolitan areas in the United States. Between 1948 and 1955, population within the area, as determined by the travel studies, increased 31 percent, from 1,110,000 to 1,454,000 persons (Table 1). Approximately 95 percent of this growth occurred beyond 4 miles of the CBD.

A comparison of the percentage distribution of population and dwelling units between 1948 and 1955 reveals that the more significant relative changes occurred between the 2-mile distance rings rather than between sectors around the CBD. The relative distribution of population had changed between rings by as much as 6 percentage points from what it had been in 1948, while 7 of the 9 sectors changed less than 1 percentage point (Table 1). Population growth was extending outward from the CBD with no major shifting

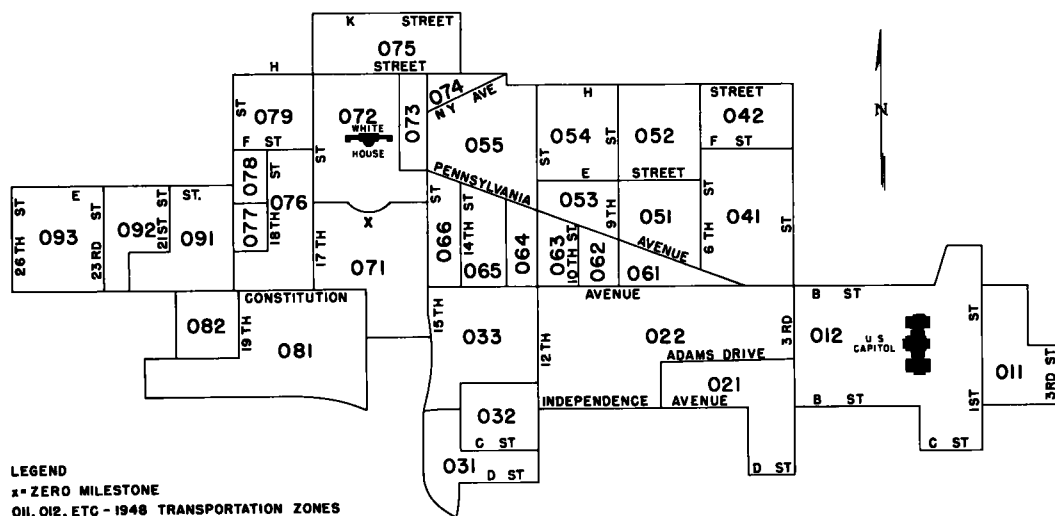

Figure 2. Central business district of Washington, D.C.

<sup>4</sup>Data concerning employment income, and retail sales were obtained from selected statistics prepared by the mass transportation staff of the National Capital Planning Commission and the National Capital Regional Planning Council.

of residents from one sector of the study area to another. The distribution of dwelling units followed the same general pattern as population.

### ANALYSIS OF DISTANCE AND DIRECTION FACTORS

The volume of intra-area travel by residents in 1955 increased 42 percent over what it had been in 1948 (Table 2). Trips to the CBD, on the other hand, increased only 4 percent, or from 255,338 to 265,659. In addition, residential (dwelling unit) growth had increased 44 percent (336,181 to 485,108), or at a rate slightly greater than trip growth (Table 1). While this resulted in a less than 2 percent decrease in total area trips per dwelling unit, trips per 100 dwelling units destined to the CBD decreased 28 percent (76 to 55).

Of greatest significance was the decrease in the proportion of trips destined to the CBD. Although there was a 4 percent increase in the actual volume, the percentage relationship of these trips to total area travel had decreased from 14.9 to 10.9 percent which presents a picture of decreasing trip orientation to the CBD.

TABLE 1  
POPULATION, DWELLING-UNIT, AND DENSITY DATA FOR 1948 AND 1955, GROUPED BY RINGS  
AND SECTORS SURROUNDING THE CENTRAL BUSINESS DISTRICT

| Area              | Population       |              |                  |              | Dwelling units |              |                |              | Number of dwelling units per residential acre, 1955 <sup>1</sup> |
|-------------------|------------------|--------------|------------------|--------------|----------------|--------------|----------------|--------------|--|
|                   | 1955             |              | 1948             |              | 1955           |              | 1948           |              |  |
|                   | Number           | Percent      | Number           | Percent      | Number         | Percent      | Number         | Percent      |  |
| <b>Rings (mi)</b> |                  |              |                  |              |                |              |                |              |  |
| 0-2               | 268,256          | 18.4         | 271,468          | 24.5         | 105,494        | 21.8         | 89,357         | 26.5         | 65.7   |
| 2-4               | 279,293          | 26.1         | 354,912          | 32.0         | 137,610        | 28.3         | 108,491        | 32.4         | 22.3   |
| 4-6               | 433,848          | 29.8         | 305,163          | 27.5         | 134,789        | 27.8         | 86,120         | 25.6         | 10.2   |
| 6-8               | 284,938          | 19.6         | 145,627          | 13.1         | 83,039         | 17.1         | 42,556         | 12.7         | 6.5  |
| 8-10              | 88,102           | 6.1          | 32,681           | 2.9          | 24,176         | 5.0          | 9,657          | 2.8          | 4.7  |
| <b>Total area</b> | <b>1,454,437</b> | <b>100.0</b> | <b>1,109,851</b> | <b>100.0</b> | <b>485,108</b> | <b>100.0</b> | <b>336,181</b> | <b>100.0</b> | <b>12.5</b>  |
| <b>Sectors</b>    |                  |              |                  |              |                |              |                |              |  |
| 0                 | 5,910            | 0.4          | 6,291            | 0.6          | 3,323          | 0.7          | 2,767          | 0.8          | 195.5  |
| 1                 | 57,565           | 4.1          | 43,146           | 3.9          | 22,267         | 4.6          | 13,205         | 4.0          | 7.8  |
| 2                 | 173,748          | 12.0         | 129,236          | 11.7         | 67,256         | 13.9         | 44,715         | 13.3         | 9.9  |
| 3                 | 367,558          | 25.3         | 321,147          | 29.1         | 128,400        | 26.5         | 98,476         | 29.3         | 21.5   |
| 4                 | 212,025          | 14.5         | 153,803          | 13.7         | 63,672         | 13.1         | 42,927         | 12.6         | 13.8   |
| 5                 | 150,466          | 10.4         | 107,168          | 9.6          | 41,816         | 8.6          | 27,704         | 8.3          | 16.7   |
| 6                 | 210,034          | 14.3         | 157,408          | 14.2         | 66,642         | 13.7         | 44,163         | 13.1         | 20.6   |
| 7                 | 149,753          | 10.3         | 115,869          | 10.4         | 51,923         | 10.7         | 40,016         | 11.9         | 9.9  |
| 8                 | 127,378          | 8.7          | 75,783           | 6.8          | 39,809         | 8.2          | 22,208         | 6.7          | 5.1  |
| <b>Total area</b> | <b>1,454,437</b> | <b>100.0</b> | <b>1,109,851</b> | <b>100.0</b> | <b>485,108</b> | <b>100.0</b> | <b>336,181</b> | <b>100.0</b> | <b>12.5</b>  |

<sup>1</sup> No comparable data available for 1948.

TABLE 2  
TRIPS TO THE CENTRAL BUSINESS DISTRICT DURING 1948 AND 1955,  
CLASSIFIED BY PURPOSE AND MODE OF TRAVEL

| Mode of travel         | Trip comparisons                      | Work trips |         | Shopping trips |         | Other trips |           | All trips |           |
|------------------------|---------------------------------------|------------|---------|----------------|---------|-------------|-----------|-----------|-----------|
|                        |                                       | 1955       | 1948    | 1955           | 1948    | 1955        | 1948      | 1955      | 1948      |
|                        |                                       |            |         |                |         |             |           |           |           |
| Automobile driver      | Total intra-area trips                | 272,987    | 164,109 | 108,498        | 45,847  | 777,700     | 418,824   | 1,158,255 | 628,780   |
|                        | Trips to CBD                          | 42,190     | 31,545  | 5,944          | 3,826   | 34,207      | 21,106    | 82,340    | 56,481    |
|                        | Percentage of trips to CBD            | 15.5       | 19.2    | 5.5            | 8.4     | 4.4         | 5.0       | 7.1       | 9.0       |
|                        | 1955 percentage/1948 percentage       | 81         | -----   | 66             | -----   | 86          | -----     | 79        | -----     |
|                        | (1955 trips to CBD)/1948 trips to CBD | 1.34       | -----   | 1.85           | -----   | 1.62        | -----     | 1.46      | -----     |
| Automobile passenger   | Total intra-area trips                | 105,879    | 59,065  | 51,020         | 22,793  | 434,116     | 274,285   | 691,015   | 356,143   |
|                        | Trips to CBD                          | 33,419     | 19,125  | 4,472          | 3,581   | 12,552      | 12,010    | 50,443    | 34,716    |
|                        | Percentage of trips to CBD            | 31.6       | 32.4    | 8.4            | 15.7    | 2.9         | 4.4       | 8.5       | 9.7       |
|                        | 1955 percentage/1948 percentage       | 98         | -----   | 55             | -----   | 65          | -----     | 88        | -----     |
|                        | (1955 trips to CBD)/1948 trips to CBD | 1.75       | -----   | 1.25           | -----   | 1.05        | -----     | 1.45      | -----     |
| Taxi passenger         | Total intra-area trips                | 13,550     | 10,017  | 2,974          | 1,901   | 41,572      | 34,558    | 58,096    | 46,476    |
|                        | Trips to CBD                          | 7,043      | 5,653   | 1,578          | 1,310   | 4,250       | 4,601     | 12,871    | 11,573    |
|                        | Percentage of trips to CBD            | 52.0       | 56.4    | 53.1           | 69.4    | 10.2        | 13.3      | 22.2      | 24.9      |
|                        | 1955 percentage/1948 percentage       | 92         | -----   | 77             | -----   | 77          | -----     | 89        | -----     |
|                        | (1955 trips to CBD)/1948 trips to CBD | 1.25       | -----   | 1.20           | -----   | 92          | -----     | 1.11      | -----     |
| Mass-transit passenger | Total intra-area trips                | 183,857    | 219,003 | 29,765         | 30,619  | 408,080     | 419,576   | 621,682   | 678,198   |
|                        | Trips to CBD                          | 79,441     | 94,543  | 19,241         | 25,683  | 21,323      | 32,342    | 120,005   | 152,668   |
|                        | Percentage of trips to CBD            | 43.2       | 43.2    | 64.6           | 84.8    | 5.2         | 7.7       | 19.3      | 22.5      |
|                        | 1955 percentage/1948 percentage       | 1.00       | -----   | 1.00           | -----   | 68          | -----     | 86        | -----     |
|                        | (1955 trips to CBD)/1948 trips to CBD | 84         | -----   | 75             | -----   | 68          | -----     | 79        | -----     |
| All modes              | Total intra-area trips                | 575,383    | 452,194 | 192,217        | 110,160 | 1,661,448   | 1,147,243 | 2,429,048 | 1,709,597 |
|                        | Trips to CBD                          | 162,922    | 150,866 | 31,235         | 34,411  | 72,332      | 70,061    | 268,659   | 255,338   |
|                        | Percentage of trips to CBD            | 28.2       | 33.4    | 16.2           | 31.2    | 4.4         | 6.1       | 10.9      | 14.9      |
|                        | 1955 percentage/1948 percentage       | 84         | -----   | 62             | -----   | 72          | -----     | 73        | -----     |
|                        | (1955 trips to CBD)/1948 trips to CBD | 1.07       | -----   | 91             | -----   | 1.04        | -----     | 1.04      | -----     |

Since this study involves measurement of the effects of distance and direction from the central area on the travel patterns to the CBD, an analysis was made to determine the "degree of trip orientation" to the CBD of the trips made by residents of each ring-sector. This was accomplished by comparing the percentage of residents trips for each ring-sector destined to the CBD with the average percentage for the total area. Residents of the ring-sectors whose percentage of trips to the CBD exceeded the average for the total area could be said to have a greater than total area average orientation to the CBD. On the other hand, residents of those ring-sectors having a percentage of trips to the CBD below the average would be considered less oriented than the area as a whole. The percentages were then ranked in class intervals of 0 to 20, 20 to 40, and 40 percent or more above or below the total area average for each of the 2 years. Figure 3 illustrates the relative orientation of trips to the CBD by residents of each ring-sector in the manner just described.

The degree of trip orientation was then compared for the 2 years to ascertain whether the general relationship of trips to the CBD had been maintained even though the percentage had decreased. In both years there were definite geographic areas which maintained a high degree of trip orientation. Residents who had a higher than average orientation in 1948, with few exceptions, retained this relative rank in 1955. Moreover, there were instances where the percentage of trips to the CBD decreased at a rate much less than that which was indicated by the average for the total area. As a result, these residents trips ranked even higher in relative orientation than they had in 1948. An example of this situation occurred in sectors 1, 2, and 3 (Figure 3).

TRIP PURPOSES

The volume of residents intra-area work trips in 1955 increased 27 percent over that of 1948 (452,194 to 575,383). Work trips to the CBD, however, increased only 7 percent, from 150,866 to 162,092 (Table 2). As a result, the percentage of work trips

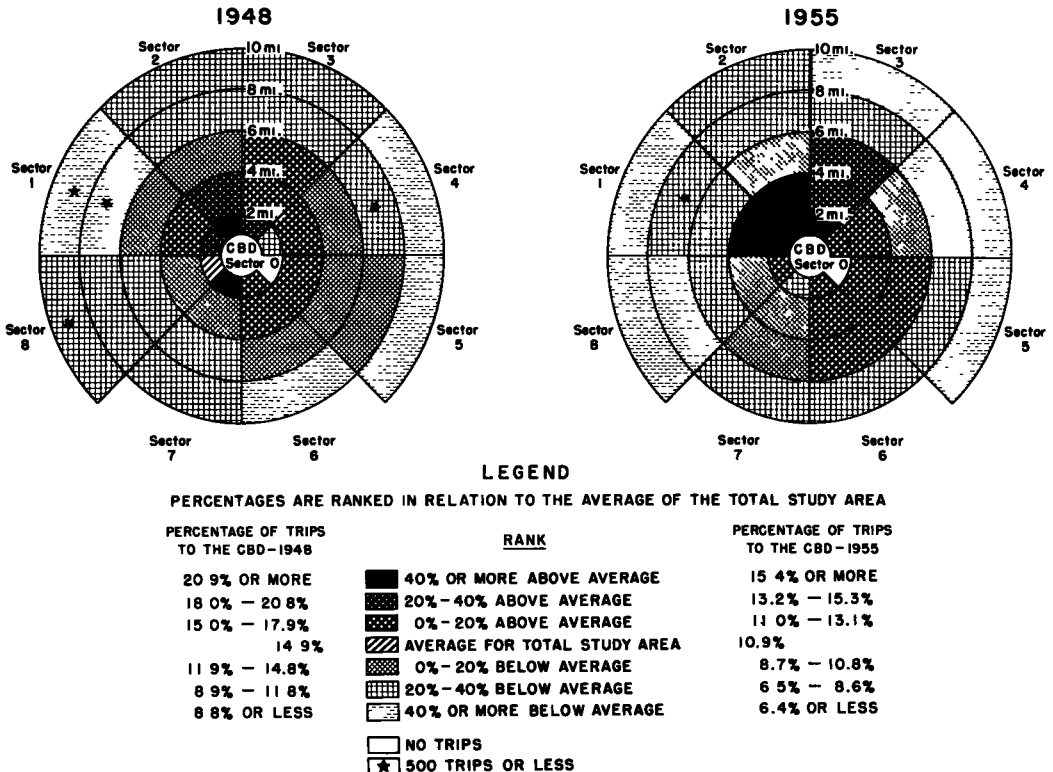

Figure 3. Percentage of intra-area trips to the CBD by residents of each ring-sector.

destined to the CBD decreased from 33.4 to 28.2 percent, or a 1955 to 1948 change ratio of 0.84. Although the CBD work trips decreased in relative importance since 1948, they had not decreased as much as shopping trips which had a change ratio of 0.52 or as much as "other" trips which had a change ratio of 0.72.

In each of the purpose categories, the proportion of CBD trips by mass transit decreased while trips by automobile increased (Table 3). In actual volume, work trips

**TABLE 3**  
**PERCENTAGE DISTRIBUTION OF TRIPS TO THE CENTRAL BUSINESS DISTRICT FOR VARIOUS PURPOSES IN 1948 AND 1955, CLASSIFIED BY MODE OF TRAVEL**

| Purpose of trip        | Automobile-driver trips |      | Automobile-passenger trips |      | Taxi-passenger trips |      | Mass-transit passenger trips |      | All trips |       |
|------------------------|-------------------------|------|----------------------------|------|----------------------|------|------------------------------|------|-----------|-------|
|                        | 1955                    | 1948 | 1955                       | 1948 | 1955                 | 1948 | 1955                         | 1948 | 1955      | 1948  |
| Work .....             | 26.0                    | 20.9 | 20.6                       | 12.7 | 4.4                  | 3.7  | 49.0                         | 62.7 | 100.0     | 100.0 |
| Ratio, 1955/1948 ..... | 1.24                    | ---  | 1.62                       | ---  | 1.19                 | ---  | .78                          | ---  | ---       | ---   |
| Shop .....             | 19.0                    | 11.1 | 14.3                       | 10.4 | 5.1                  | 3.9  | 61.6                         | 74.6 | 100.0     | 100.0 |
| Ratio, 1955/1948 ..... | 1.71                    | ---  | 1.38                       | ---  | 1.31                 | ---  | .83                          | ---  | ---       | ---   |
| Other .....            | 47.3                    | 30.1 | 17.3                       | 17.1 | 5.9                  | 6.6  | 29.5                         | 16.2 | 100.0     | 100.0 |
| Ratio, 1955/1948 ..... | 1.57                    | ---  | 1.01                       | ---  | .89                  | ---  | .64                          | ---  | ---       | ---   |
| All purposes .....     | 31.0                    | 22.1 | 19.0                       | 13.6 | 4.8                  | 4.5  | 45.2                         | 59.2 | 100.0     | 100.0 |
| Ratio, 1955/1948 ..... | 1.40                    | ---  | 1.40                       | ---  | 1.07                 | ---  | .76                          | ---  | ---       | ---   |

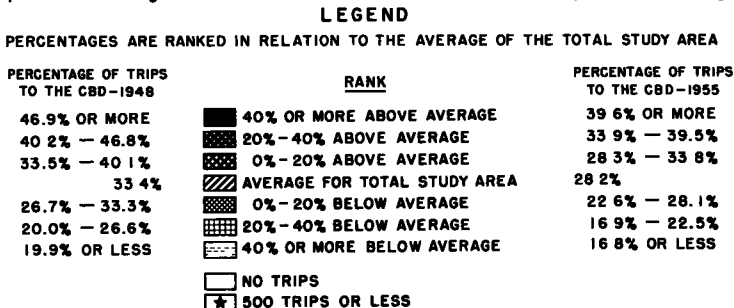
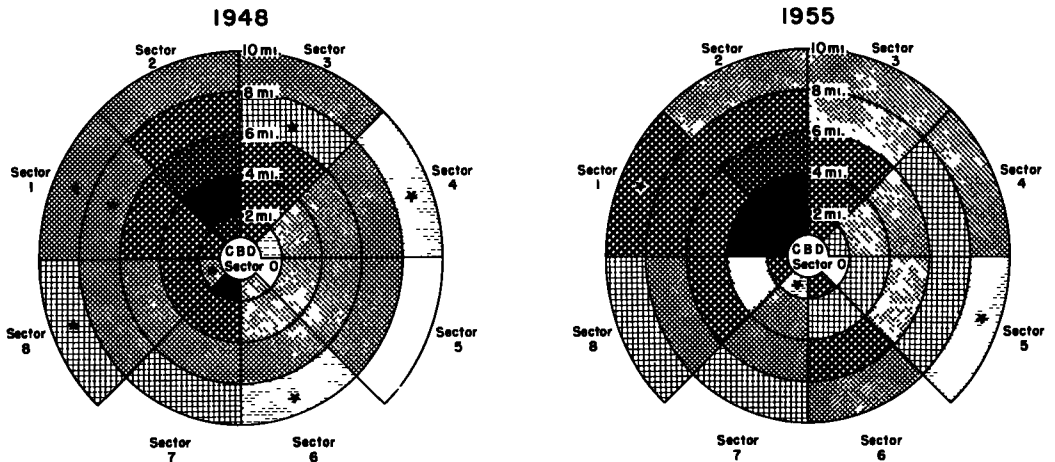

Figure 4. Percentage of intra-area work trips to the CBD by residents of each ring-sector.

by mass transit decreased from 94,543 to 79,441 (Table 2). However, the 1955 to 1948 change ratio indicated that mass-transit work trips had an index of 1.00. The decreasing use of mass transit for travel to work was a general trend throughout the study area and not particularly characteristic of only the work trips to the CBD. This same characteristic applied to shopping trips to the CBD by mass transit.

The increasing proportion of work trips to the CBD by automobile passengers indicated a greater use of car pools. In the Washington study area, mounting congestion, increased costs in driving and parking, and less convenient transit service in suburban areas have done much to encourage the forming of car pools by residents who must travel to the CBD day after day.

The volume of shopping trips within the study area increased 74 percent between 1948 and 1955 (110,160 to 192,217 trips). In contrast, the number destined to the CBD decreased 9 percent from 34,411 to 31,235 trips (Table 2). This decrease in the number of CBD shopping trips was reflected in the relative decline in the dollar volume of retail sales discussed earlier.

This decline in the volume of CBD shopping trips, however, does not so vividly illustrate the decreased importance of the CBD for shopping as does the comparison between 1948 and 1955 of the percentage of total area shopping trips destined to the CBD (31 percent in 1948 and 16 percent in 1955). This sizable decrease reflects the increasing development as well as the attraction of commercial concentrations outside the CBD.

The CBD shopping trip ratio of automobile passengers to that of automobile drivers decreased from an average of 94 passengers in 1948 to 75 passengers for every 100 automobile drivers in 1955. This was in contrast to the trend for work trips which increased from an average of 61 automobile passengers in 1948 to 79 for every 100 automobile drivers in 1955.

From these comparisons there is an indication of a decrease in the number of family trips made to the CBD for shopping. The physical layout and the facilities offered in the outlying shopping centers were more conducive to family shopping than those located in the CBD.

Since trips classified as "other" include a wide range of purposes, any comparisons of 1948 and 1955 data should be qualified. "Other" trips to the CBD increased 3 percent in 1955 over what they had been in 1948 (70,061 to 72,332). Compared to the 45 percent increase in the total intra-area trips for this group (Table 2), the increase in trips to the CBD was small.

As was also found for work and shopping trips, the proportion of "other" trips to the CBD had decreased relative to the total number of "other" residents trips. This comparison applies to an average of a group of purposes, and some purposes were above and some below this average.

Notable for "other" trips to the CBD was the comparatively large increase in the volume of automobile-driver trips (62 percent), whereas there was a comparatively slight increase in the volume of automobile-passenger trips (5 percent). As in shopping trips, group and family trips to the CBD compared with those made to other parts of the study area appeared to be relatively less, and those that were made by an individual (such as a visit to a doctor or a business trip) were apparently increasing. A separate geographical grouping of residents with a high degree of trip orientation was found for each of the three trip purposes studied (Figures 4-6). As indicated in Figure 4, the largest continuous area of residents with an above average work trip orientation was located in both study years within sectors 1,2, and 3. On the other hand, Figure 5 which shows the same information for shopping trips indicates that residents having an above average trip orientation for shopping were located within an entirely different geographical grouping. Hence, the degree of orientation varied between trip purposes within any one ring-sector.

Between 1948 and 1955 there was no major shifting of these geographical groupings of above-average orientation from one part of the study area to another, even though the percentage of trips destined to the CBD decreased for each purpose. There were, however, extensions of the relative rank of above-average orientation which had existed



in 1948 among residents in ring-sectors closer to the CBD. In the case of shopping and "other" trips, no radial pattern of above-average orientation extended beyond a radius of 6 miles in 1955 as was the case for work trips.

### MODES OF TRAVEL

The major change observed in residents choice of mode of travel to the CBD was the increased use of private automobiles and conversely the decreased use of mass transit (Table 3). The volume of automobile-driver and automobile-passenger trips to the CBD in 1955 had approximately the same percentage increase over that of 1948, 46 and 45 percent, respectively (Table 2). As has been pointed out, the increased proportion of automobile-passenger trips in the work category offset the lesser proportions in the other categories. The over-all average of the number of automobile passengers to the number of automobile drivers traveling to the CBD remained approximately the same, 61.5 automobile passengers to every 100 automobile drivers in 1948 and 61.3 in 1955.

The volume of taxi-passenger trips to the CBD by residents increased 11 percent, from 11,573 to 12,871 trips (Table 2).

There was a decrease in the percentage of trips destined to the CBD for each mode of travel. The mode of travel with the greatest relative change was automobile-driver trips, which had a change ratio of 0.79 (Table 2). Even though the volume of automobile-driver trips to the CBD increased 46 percent over the period 1948 to 1955, trips to places outside the CBD had increased by an even greater percentage (88 percent).

The trip purposes for each travel mode indicate two significant characteristics (Table 4). First, approximately one-half to two-thirds of the total volume of trips by each mode of travel in 1948 and 1955 were to work. Second, with the exception of automobile-driver trips, each of the modes of travel studied had a greater percentage

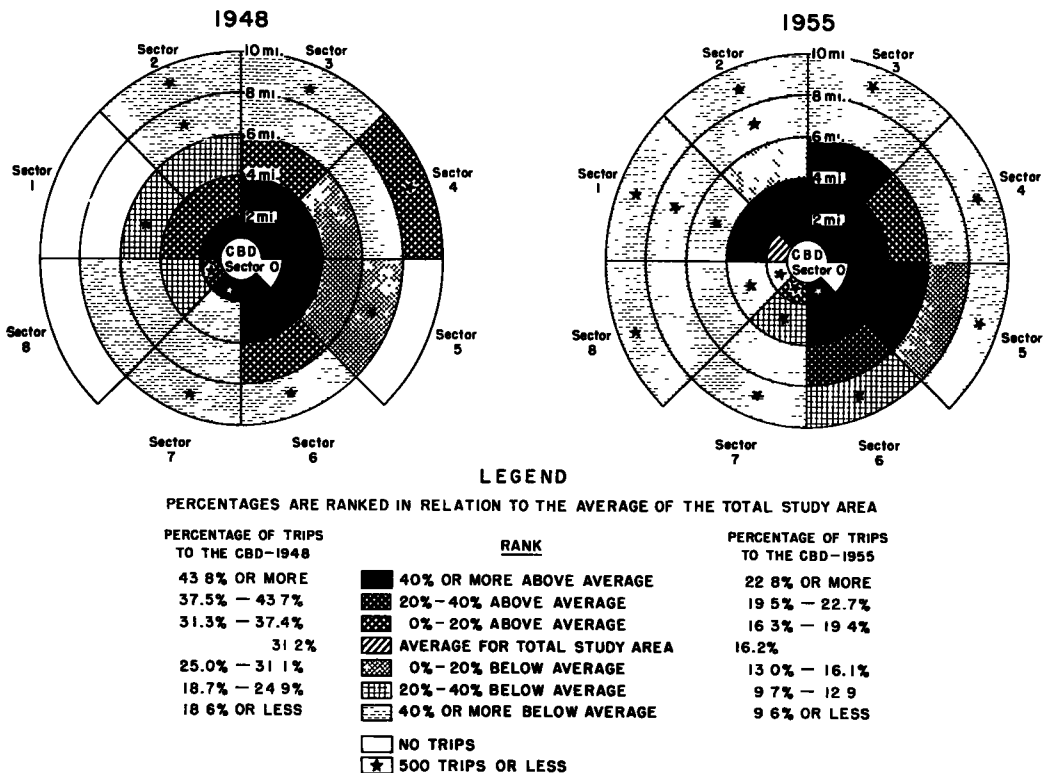

Figure 5. Percentage of intra-area shopping trips to the CBD by residents of each ring-sector.

of trips to work in 1955 and a smaller percentage for "other" purposes than was the case in 1948.

The increase in the percentage of automobile-driver trips made for "other" purposes reflects the increase of automobile ownership (61 cars per 100 dwelling units in 1948 and 79 in 1955). With the increased availability of an automobile as well as a general

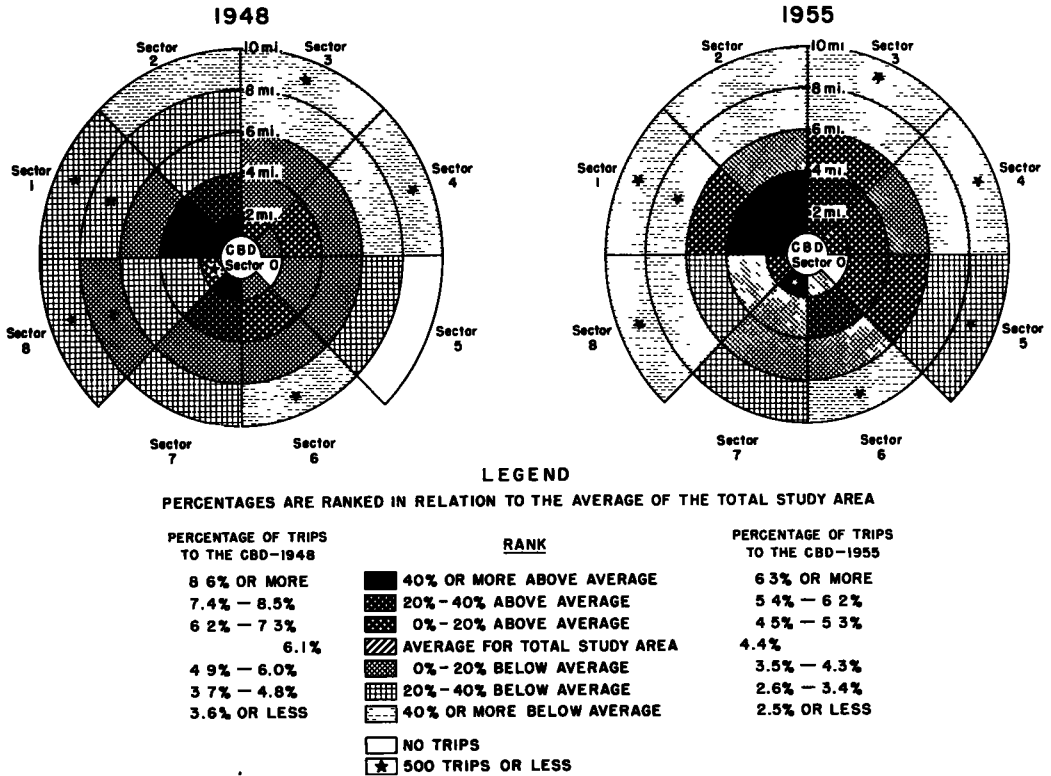

Figure 6. Percentage of intra-area "other" trips to the CBD by residents of each ring-sector.

**TABLE 4**  
**PERCENTAGE DISTRIBUTION OF TRIPS TO THE CENTRAL BUSINESS DISTRICT BY VARIOUS MODES OF TRAVEL IN 1948 AND 1955, CLASSIFIED BY PURPOSE**

| Mode of travel              | Work trips |      | Shopping trips |      | Other trips |      | All trips |       |
|-----------------------------|------------|------|----------------|------|-------------|------|-----------|-------|
|                             | 1955       | 1948 | 1955           | 1948 | 1955        | 1948 | 1955      | 1948  |
| Automobile driver.....      | 51.2       | 55.9 | 7.2            | 6.8  | 41.6        | 37.3 | 100.0     | 100.0 |
| Ratio, 1955/1948.....       | .92        | ---  | 1.06           | ---  | 1.12        | ---  | ---       | ---   |
| Automobile passenger.....   | 66.2       | 55.1 | 8.9            | 10.3 | 24.9        | 34.6 | 100.0     | 100.0 |
| Ratio, 1955/1948.....       | 1.20       | ---  | .86            | ---  | .72         | ---  | ---       | ---   |
| Taxi passenger.....         | 54.7       | 48.8 | 12.3           | 11.4 | 33.0        | 39.8 | 100.0     | 100.0 |
| Ratio, 1955/1948.....       | 1.12       | ---  | 1.08           | ---  | .83         | ---  | ---       | ---   |
| Mass-transit passenger..... | 66.2       | 62.0 | 16.0           | 16.8 | 17.8        | 21.2 | 100.0     | 100.0 |
| Ratio, 1955/1948.....       | 1.07       | ---  | .95            | ---  | .84         | ---  | ---       | ---   |
| All modes of travel.....    | 61.0       | 59.1 | 11.8           | 13.5 | 27.2        | 27.4 | 100.0     | 100.0 |
| Ratio, 1955/1948.....       | 1.03       | ---  | .87            | ---  | .99         | ---  | ---       | ---   |

trend of an increase in the number of individuals licensed to drive, there was the tendency to drive to the luncheon engagement or to the night school in the CBD.

The degree of trip orientation that residents had in 1948 and 1955 indicated that there was a separate geographical grouping of ring-sector residents with above-average orientation for each of the modes used in traveling to the CBD (Figures 7-10). However, many of the radial patterns of above-average orientation, as seen in 1948 for each mode, were not so apparent in 1955. Residents beyond 6 miles showed a greater tendency to have a lower degree of trip orientation to the CBD in 1955 for each of the modes of travel than they had in 1948. Thus, the general relationship (rank) between ring-sector residents and the CBD, as related to the average percentage for each mode of travel, changed and a geographical regrouping took place rather than an extension of the relative rank of orientation, as in purpose of trip. The pattern in 1955 appeared to be more of a readjustment of travel, linked possibly with the growth of new centers of attraction outside the CBD as well as increased automobile ownership.

The percentage of total CBD trips made by residents of each ring-sector is illustrated in Figures 11 and 12. As is indicated, there were many changes between 1948 and 1955 in the relative distribution of residents trip purposes and the modes used to travel. These changes and others as they relate to distance and direction from the CBD are discussed in the sections that follow.

### ANALYSIS OF DISTANCE FACTOR

The attitude of residents concerning distances from the central part of the city may change, even in so short a period as 7 years. A travel distance of 10 miles to the CBD in 1955 was not considered unusual, whereas in 1948 residents would have felt that the distance was too great. This changed attitude did not develop simultaneously in all directions from the CBD. Therefore, the averages used in discussing distance ring

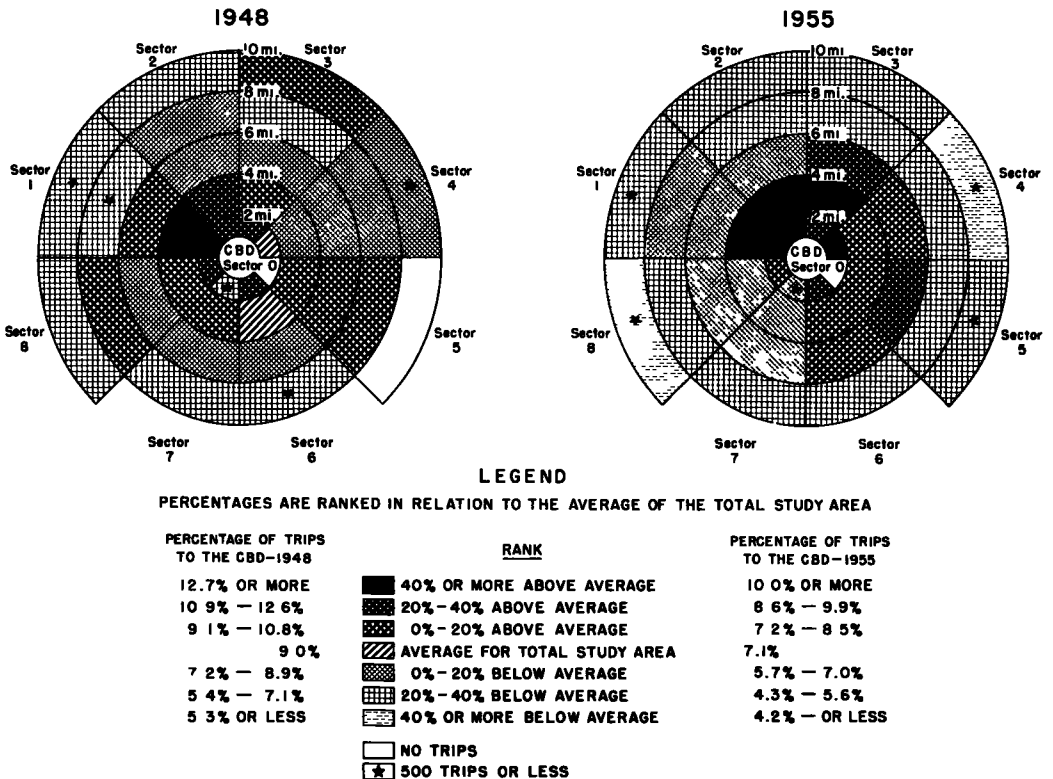

Figure 7. Percentage of intra-area automobile driver trips to the CBD by residents of each ring-sector.

characteristics vary to a certain extent between sectors of a ring.

In this study of the effects of distance upon residents travel, several changes of a significant nature are apparent. The first, as seen in Table 5, is a decrease in the actual volume of trips to the CBD by residents within 4 miles of the CBD and an increase in the number of residents trips beyond this distance. Secondly, as brought out in Table 5, there was a decrease of approximately the same magnitude, 3 percent, in the proportion of trips destined to the CBD by residents of each of the rings.

**TABLE 5**  
**TRIPS TO THE CENTRAL BUSINESS DISTRICT IN 1948 AND 1955,**  
**CLASSIFIED ACCORDING TO PURPOSE AND DISTANCE OF**  
**RESIDENCE FROM THE CBD**

| Trip purpose comparisons                 | 0 to 2 miles |         | 2 to 4 miles |         | 4 to 6 miles |         | 6 to 8 miles |         | 8 to 10 miles |        | Total area |           |
|--|--------------|---------|--------------|---------|--------------|---------|--------------|---------|---------------|--------|------------|-----------|
|  | 1955         | 1948    | 1955         | 1948    | 1955         | 1948    | 1955         | 1948    | 1955          | 1948   | 1955       | 1948      |
| <b>Work trips</b>                        |              |         |              |         |              |         |              |         |               |        |            |           |
| Total intra-area trips.....              | 101,239      | 107,962 | 161,175      | 155,674 | 175,317      | 125,071 | 106,331      | 51,452  | 31,321        | 12,045 | 575,363    | 482,194   |
| Trips to CBD.....                        | 31,944       | 27,387  | 47,562       | 54,504  | 50,363       | 41,506  | 24,266       | 14,133  | 7,937         | 3,314  | 163,092    | 150,866   |
| Percentage of trips to CBD.....          | 31.6         | 34.6    | 29.5         | 35.0    | 28.7         | 33.2    | 22.8         | 27.5    | 25.3          | 27.5   | 28.2       | 31.4      |
| 1955 percentage/1948 percentage.....     | 91           | 85      | 84           | 87      | 86           | 85      | 83           | 82      | 82            | 82     | 84         | 84        |
| 1955 trips to CBD/1948 trips to CBD..... | 85           | 85      | 87           | 87      | 1.21         | 1.21    | 1.71         | 1.71    | 2.39          | 2.39   | 1.07       | 1.07      |
| <b>Shopping trips</b>                    |              |         |              |         |              |         |              |         |               |        |            |           |
| Total intra-area trips.....              | 16,557       | 13,599  | 36,462       | 31,674  | 66,744       | 42,297  | 52,801       | 18,493  | 10,663        | 4,107  | 192,217    | 110,180   |
| Trips to CBD.....                        | 7,546        | 8,936   | 10,062       | 12,040  | 9,725        | 9,907   | 3,337        | 2,847   | 566           | 681    | 31,225     | 34,411    |
| Percentage of trips to CBD.....          | 45.6         | 65.7    | 27.6         | 38.0    | 14.6         | 23.4    | 6.3          | 15.4    | 5.2           | 16.6   | 16.2       | 31.2      |
| 1955 percentage/1948 percentage.....     | 69           | 89      | 73           | 62      | 62           | 41      | 17           | 17      | 87            | 87     | 52         | 52        |
| 1955 trips to CBD/1948 trips to CBD..... | 84           | 84      | 98           | 98      | 1.17         | 1.17    | 1.17         | 1.17    | 1.17          | 1.17   | 91         | 91        |
| <b>Other trips</b>                       |              |         |              |         |              |         |              |         |               |        |            |           |
| Total intra-area trips.....              | 226,002      | 218,055 | 397,988      | 376,868 | 632,231      | 486,204 | 377,624      | 152,482 | 127,603       | 34,604 | 1,661,448  | 1,147,243 |
| Trips to CBD.....                        | 17,313       | 19,751  | 21,914       | 25,394  | 21,461       | 18,467  | 8,912        | 5,586   | 2,732         | 863    | 72,332     | 70,061    |
| Percentage of trips to CBD.....          | 7.7          | 9.1     | 5.5          | 6.7     | 4.0          | 5.0     | 2.4          | 3.7     | 2.1           | 2.6    | 4.4        | 6.1       |
| 1955 percentage/1948 percentage.....     | 85           | 85      | 82           | 80      | 80           | 65      | 65           | 61      | 61            | 61     | 72         | 72        |
| 1955 trips to CBD/1948 trips to CBD..... | 88           | 88      | 86           | 86      | 1.16         | 1.16    | 1.60         | 1.60    | 3.17          | 3.17   | 1.03       | 1.03      |
| <b>All purposes</b>                      |              |         |              |         |              |         |              |         |               |        |            |           |
| Total intra-area trips.....              | 443,798      | 339,646 | 595,615      | 564,216 | 774,292      | 534,572 | 536,786      | 222,417 | 178,867       | 49,746 | 2,429,048  | 1,706,597 |
| Trips to CBD.....                        | 56,802       | 66,074  | 79,568       | 91,938  | 81,549       | 69,882  | 36,505       | 22,566  | 11,236        | 4,868  | 256,659    | 235,336   |
| Percentage of trips to CBD.....          | 12.8         | 19.5    | 13.4         | 16.3    | 10.5         | 13.1    | 6.8          | 10.2    | 6.3           | 9.8    | 10.9       | 14.9      |
| 1955 percentage/1948 percentage.....     | 85           | 85      | 82           | 80      | 80           | 67      | 67           | 64      | 64            | 64     | 73         | 73        |
| 1955 trips to CBD/1948 trips to CBD..... | 86           | 86      | 87           | 87      | 1.17         | 1.17    | 1.62         | 1.62    | 2.31          | 2.31   | 1.04       | 1.04      |

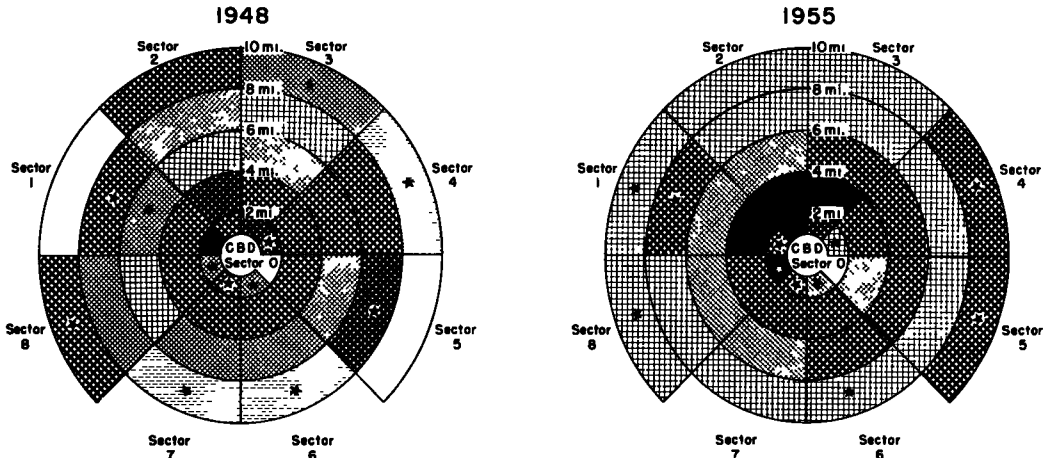

**LEGEND**  
 PERCENTAGES ARE RANKED IN RELATION TO THE AVERAGE OF THE TOTAL STUDY AREA

| PERCENTAGE OF TRIPS TO THE CBD-1948 | RANK                         | PERCENTAGE OF TRIPS TO THE CBD-1955 |
|-------------------------------------|------------------------------|-------------------------------------|
| 13.8% OR MORE                       | 40% OR MORE ABOVE AVERAGE    | 12.0% OR MORE                       |
| 11.9% - 13.7%                       | 20%-40% ABOVE AVERAGE        | 10.3% - 11.9%                       |
| 9.9% - 11.8%                        | 0% - 20% ABOVE AVERAGE       | 8.6% - 10.2%                        |
| 9.8%                                | AVERAGE FOR TOTAL STUDY AREA | 8.5%                                |
| 7.8% - 9.7%                         | 0% - 20% BELOW AVERAGE       | 6.8% - 8.4%                         |
| 5.9% - 7.7%                         | 20%-40% BELOW AVERAGE        | 5.1% - 6.7%                         |
| 5.8% OR LESS                        | 40% OR MORE BELOW AVERAGE    | 5.0% OR LESS                        |
|                                     | NO TRIPS                     |                                     |
|                                     | ★ 500 TRIPS OR LESS          |                                     |

Figure 8. Percentage of intra-area automobile passenger trips to the CBD by residents of each ring-sector.

The pattern in which the percentage of trips destined to the CBD decreased was also significant (Table 5). In 1955 the percentage for each of the first three distance rings was approximately the same as the percentage for the next outer ring in 1948. For example, in 1955, residents within 2 miles of the CBD made 16.5 percent of their total trips to the CBD; this was approximately the same percentage as for residents within 2 to 4 miles of the CBD in 1948. If this trend were to continue for the following 7 years, the residents within 2 miles of the CBD in 1962 would make approximately the same percentage of trips to the CBD in residents 2 to 4 miles from the CBD made in 1955, or 13 percent; residents 2 to 4 miles and 4 to 6 miles from the CBD would make 10 and 6 percent, respectively, of their trips to the CBD in 1962. The percentage of trips to the CBD by residents 6 to 8 and 8 to 10 miles from the CBD did not fit the pattern of change just described. The percentage for both rings was approximately the same in each year. This similarity in the two outer rings, which are basically suburban, suggests that residents of suburban areas tend to have a more similar orientation to the CBD than urban areas closer to the CBD.

A significant factor in the distribution by distance of residents CBD trips was the leveling off which occurred between 2 to 4 miles and 4 to 6 miles of the CBD (Table 6 and Figure 13), a characteristic also observed in the distribution of dwelling units. In 1948, the major proportion of trips to the CBD were made by residents within 2 to 4 miles of the CBD. At that time, residents of this ring accounted for 91,938 or 36 percent of the total trips to the CBD. In 1955, however, the number of CBD trips made by residents within 2 to 4 miles had decreased and similar trips made by residents within 4 to 6 miles had increased. As a result, the number of trips from the two rings were about the same, 79,568 and 81,549, respectively.

This characteristic of residents trips to the CBD is important in estimating future trip distribution. Theoretically, it is altogether possible that total trips to the CBD made by residents of each of the five distance rings could approach, although not reach,

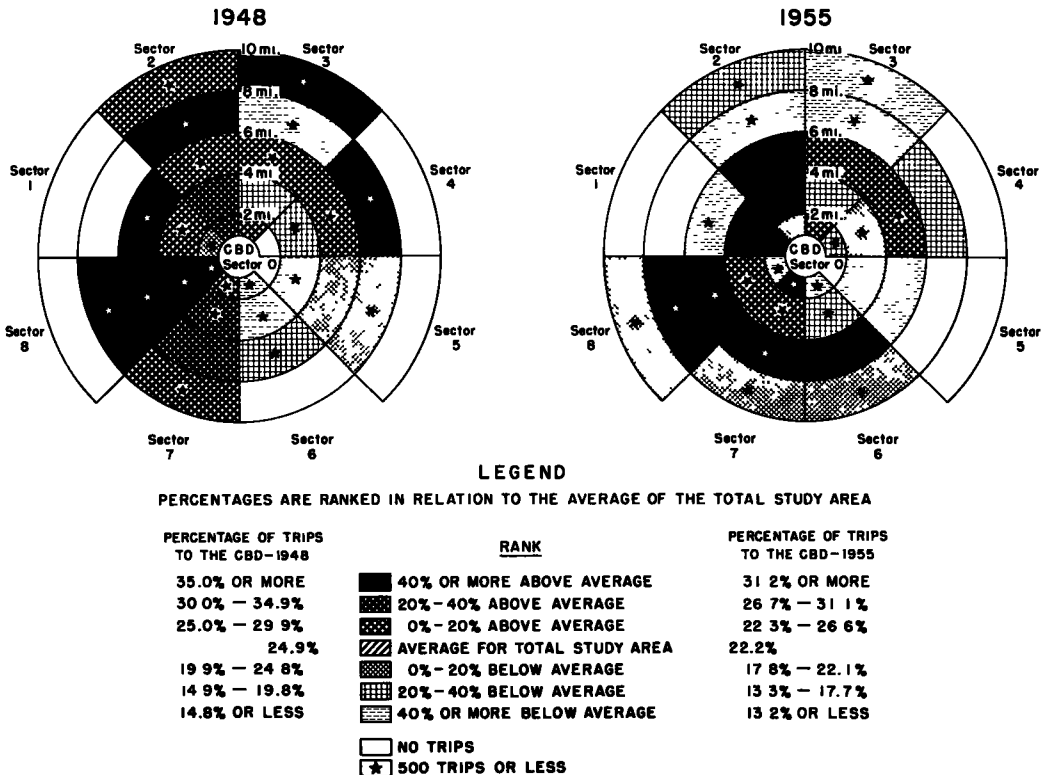

Figure 9. Percentage of intra-area taxi passenger trips to the CBD by residents of each ring-sector.



Two observations support this possible trend in residents trip distribution. The first was the greater uniformity in the number of CBD trips per 100 dwelling units throughout the five distance rings in 1955 (Table 7); the range in the number of trips was from 44 to 61, or a difference of 17. In 1948, the range in the number of trips among distance rings was from 50 to 85, or a difference of 35.

The second observation has to do with the increase in the proportion of dwelling units located between 6 and 10 miles of the CBD (Table 1). In 1948, this area contained 15.5 percent of the total dwelling units within the study area; by 1955, the proportion had increased to 22.1 percent. Each consecutive ring circumscribed a much larger area than the preceding ring. Even though residential density per acre is progressively less

TABLE 7

NUMBER OF TRIPS PER 100 DWELLING UNITS TO THE CENTRAL BUSINESS DISTRICT IN 1948 AND 1955, CLASSIFIED ACCORDING TO PURPOSE AND DISTANCE OF RESIDENCE FROM THE CBD

| Distances from CBD        | Work trips |      | Shopping trips |      | Other trips |      | All purposes |      |
|---------------------------|------------|------|----------------|------|-------------|------|--------------|------|
|                           | 1955       | 1948 | 1955           | 1948 | 1955        | 1948 | 1955         | 1948 |
| 0-2 miles .....           | 30.3       | 41.8 | 7.2            | 10.0 | 16.4        | 22.1 | 53.8         | 73.9 |
| 2-4 miles .....           | 34.6       | 50.2 | 7.3            | 11.1 | 15.9        | 23.4 | 57.8         | 84.7 |
| 4-6 miles .....           | 37.4       | 48.2 | 7.2            | 11.5 | 15.9        | 23.4 | 60.5         | 81.1 |
| 6-8 miles .....           | 29.2       | 33.3 | 4.0            | 6.7  | 10.7        | 13.1 | 44.0         | 53.1 |
| 8-10 miles .....          | 32.8       | 34.3 | 2.3            | 7.1  | 11.3        | 8.9  | 46.5         | 50.3 |
| Average, total area ..... | 33.4       | 44.9 | 6.4            | 10.2 | 14.9        | 20.8 | 54.8         | 76.0 |

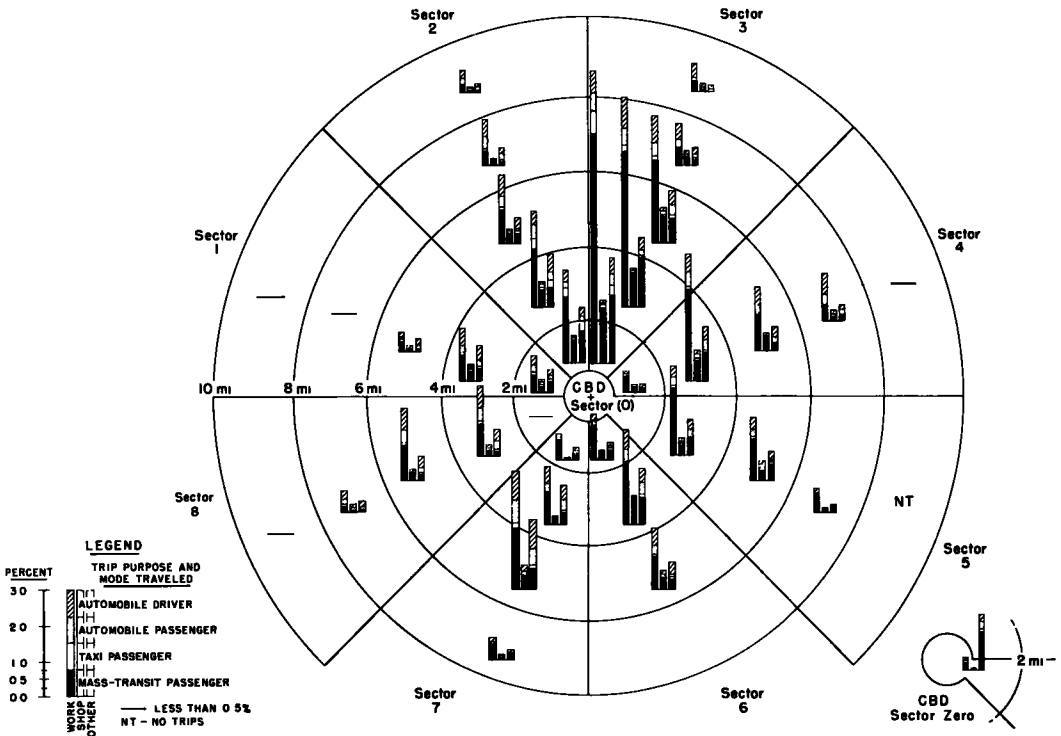

Figure 11. Relation of residents trips of each ring-sector to total area trips made to the central business district in 1948, according to purpose and mode of travel.

as distance from the CBD increases, the larger area of each consecutive ring permits a corresponding increase in the number of residences within each ring when fully developed. This has occurred in the 2- to 4- and 4- to 6-mile distance rings. In 1955, the densities within these rings were 22.3 and 10.2 dwelling units per acre, respectively, but the total number of residences for the 2 rings were nearly equal, 137,610 and 134,789.

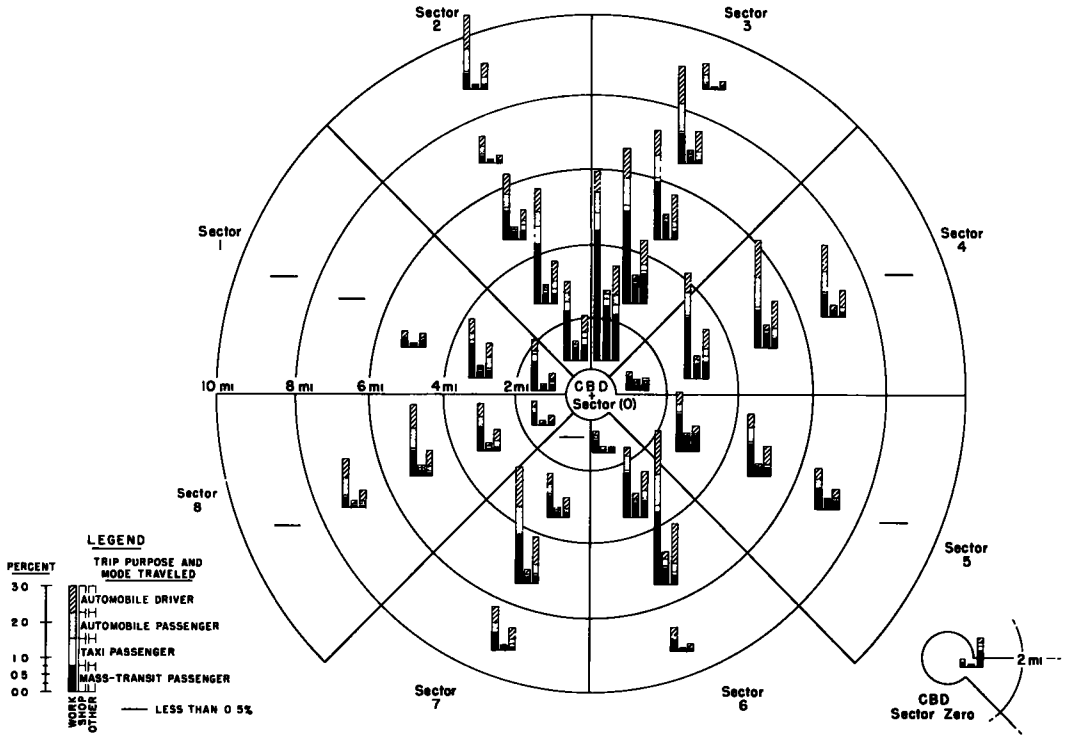

Figure 12. Relation of residents trips of each ring-sector to total area trips made to the central business district in 1955, according to purpose and mode of travel.

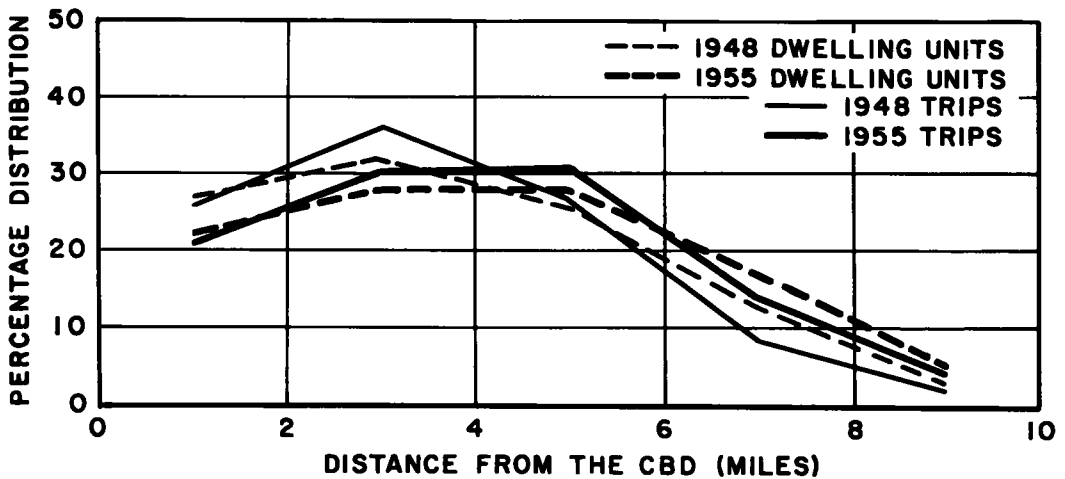

Figure 13. Percentage distribution of trips to the central business district of Washington, D.C., compared to that of dwelling units, by distance of residence from the CBD average weekday-1948 and 1955.





respectively. The changes that occurred during the 7-year period are illustrated graphically in Figure 14. As work trips made up a major portion of the total CBD trips, it is apparent that residents work trips were an important factor in the leveling of the distribution curve.

In the future an increasing percentage of CBD work trips is expected to be made by residents of the outer rings, extending the plateau of percentage distribution at a lower percentage level over an even wider area than in 1955. As shown in Table 7, the range among distance rings for work trips destined to the CBD per 100 dwelling units was only half as great in 1955 as it was in 1948. If this range of difference were to be maintained or decreased even more, then those rings with the greatest future growth in residential

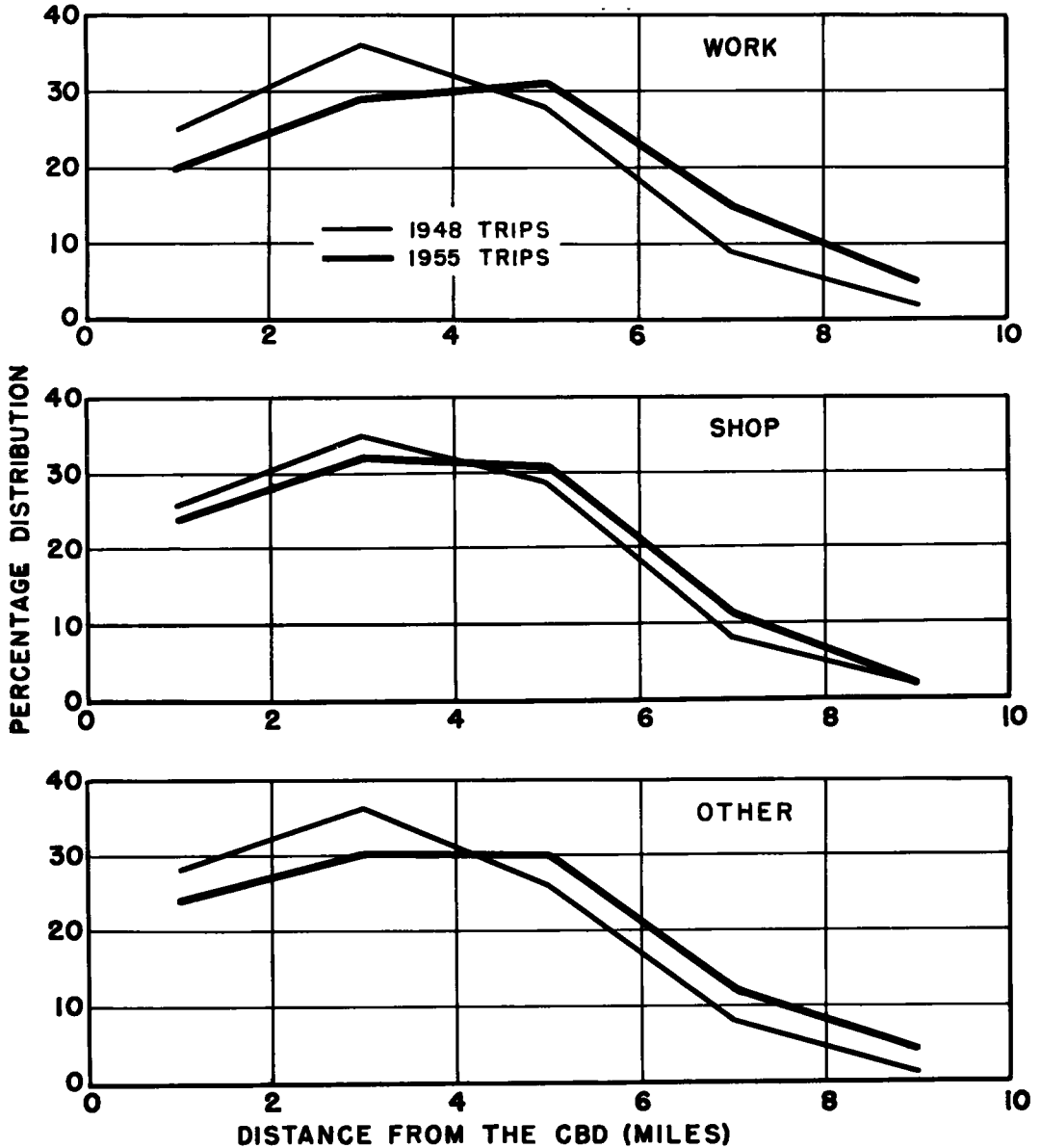

Figure 14. Percentage distribution of trips to the central business district of Washington, D.C., by purpose and distance of residence from the CBD average weekday-1948 and 1955.



It should be noted that the percentage of residents work trips made by mass transit in 1955 for any given distance ring was approximately the same as the percentage in 1948 for the next outer ring. For example, in 1955, residents within 2 miles of the CBD made 64.8 percent of their work trips by mass transit; in 1948 residents within 2 to 4 miles made approximately the same percentage, 65.7. This same relationship follows regardless of distance ring. If this same pattern were to continue in the 7 years following 1955, then by 1962 only the residents within 2 miles of the CBD would make over 50 percent of their work trips to the CBD by mass transit.

### Shopping Trips

The percentage distribution of residents shopping trips to the CBD changed less between the five distance rings than the distribution of work or "other" trips, even though there was a decrease in the total volume of shopping trips to the CBD between 1948 and 1955. Of the relative changes that did take place, however, the most significant was the apparent leveling off of the peak of trip distribution within 2 to 4 miles of the CBD (Figure 14). Residents within 2 to 4 and 4 to 6 miles of the CBD in 1955 made 32.2 and 31.1 percent, respectively, of the shopping trips to the CBD (Table 6).

In the previous discussion of work trips it was mentioned that with growth in residential development beyond 6 miles of the CBD, the leveling of the distribution curve would likely extend over an even wider area than in 1955, and this would result in a more uniform distribution of residents work trips to the CBD. In the case of shopping trips, however, there is no basis for such speculation.

Between 1948 and 1955 the average number of daily shopping trips to the CBD per 100 dwelling units decreased in each of the 2-mile rings, and the percentage decrease became progressively greater with distance from the central area (Table 7). It is evident that residents, particularly those within the first three distance rings, were patronizing stores outside the CBD for many of their needs and relied on the CBD stores for shopping goods merchandise or for items where a greater selection was desired. In the case of the outlying communities (beyond 6 miles of the CBD), residents had ready access to major shopping areas which could supply practically all of their needs. Two department stores had a suburban branch in 1948, and these were relatively small in sales floor area. By 1955, one or more branches had been established by each of the large department stores and by many of the large specialty stores.

In 1948 the area between 6 and 10 miles of the CBD contained approximately 52,200 dwelling units and accounted for a total of 22,600 intra-area shopping trips; of this number, 3,500 were made to the CBD. By 1955 the number of dwelling units had increased to 107,200 and intra-area shopping trips had increased to 72,500; yet, of these trips, only 3,900 were to the CBD. The percentage of intra-area shopping trips destined to the CBD decreased during the 7-year period from 15.6 to 5.4 percent, a change ratio of 0.35.

Of the changes in mode of travel, the most significant was the decreased distance from the CBD in which mass transit accounted for one-half or more of residents shopping trips to the CBD (Table 9). In 1948 residents within 8 miles of the CBD used mass transit for more than half of their trips; in 1955, the same ratio applied only to residents within 6 miles.

Mass-transit passenger travel, although decreasing in the relative percentage of total shopping trips destined to the CBD, nevertheless accounted for about three-fourths of all shopping trips made to the CBD by residents within a 2-mile radius and two-thirds of such trips by residents within 2 to 4 miles of the CBD. These high percentages were maintained because of the large number of well distributed, converging transit lines which provided the more densely populated rings with convenient passenger service to the retail core of the CBD.

The only group to show an increase between 1948 and 1955 in the percentage of shopping trips by mass transit were residents of the 8- to 10-mile ring. This apparent inconsistency may be due to sample variability, as the total number of shopping trips to the downtown area by residents of this ring was relatively small, the calculated figure being 681 in 1948 and 566 in 1955. Since the sampling rate was 1 in 20 in this area in 1948 and 1 in 10 in 1955, the number of residents interviewed was only 34 in the first



were in the 50 percent or more category in 1948. By 1955, the use of the private automobile had increased to the point that even residents at this distance made less than 50 percent of their total "other" purpose trips by mass transit.

### MODES OF TRAVEL

In 1948 and 1955, the proportion of total residents trips to the CBD made by mass-transit passengers and taxi passengers decreased with distance from the CBD while those made by automobile drivers and automobile passengers increased (Table 9). The major change which did take place between 1948 and 1955 was a shift in the mode of travel. In 1955, there was a smaller percentage of total residents trips to the CBD in each ring that were made by mass-transit passengers, whereas the proportion of the CBD trips made by automobile drivers and automobile passengers increased.

In the subsequent discussion of taxi-passenger trips, it must be kept in mind that only residents taxi trips are included in this study. A very large proportion of taxi-passenger trips are made by nonresidents (transients and tourists).

#### Automobile Drivers

The percentage distribution of trips to the CBD, classified according to mode of travel and distance, is shown in Table 10 and Figure 15. There was approximately the same percentage of automobile-driver trips to the CBD made by residents 2 to 4 and 4 to 6 miles from the CBD in 1948, 34.2 percent and 34.3 percent, respectively. This similarity disappeared in 1955. Residents within 4 to 6 miles made by far the largest percentage of automobile-driver trips to the CBD, 36.3 percent.

Although residents of the 2- to 4-mile ring had a substantially smaller average number of automobile-driver trips to the CBD per 100 dwelling units in 1948 than that observed for residents of the 4- to 6-mile ring (Table 11), the 2- to 4-mile ring included more dwelling units. This offsetting factor accounted for the similar percentage of the total automobile-driver trips destined to the CBD by residents of these two rings in 1948.

In contrast, the 4- to 6-mile ring in 1955 contained approximately as many dwelling units as the 2- to 4-mile ring. This characteristic, plus the fact that in 1955 residents 4 to 6 miles from the CBD continued to make approximately the same number of automobile-driver trips to the CBD per 100 dwelling units as they did in 1948, while the number of trips per 100 dwelling units in the 2- to 4-mile ring decreased. These factors caused the change in the distribution pattern in 1955.

The general tendency in 1948 and 1955 was for the average number of automobile-driver trips to the CBD per 100 dwelling units to increase for the first few rings and then remain at about the same level beyond 6 miles of the CBD. With an increase in residential development in the outer two rings, the percentage distribution curve for automobile drivers might tend to flatten beyond 4 miles and possibly

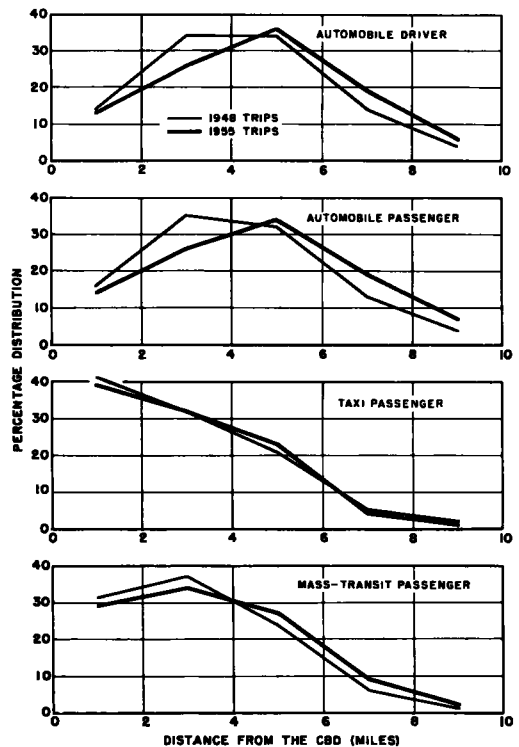

Figure 15. Percentage distribution of trips to the central business district of Washington, D.C. by mode of travel and distance of residence from the CBD average weekday-1948 and 1955.

extend over a greater distance than in 1948. This trend appeared to be taking place in 1955, as residents 6 to 8 and 8 to 10 miles from the CBD made one-fourth (25.6 percent) of the total automobile-driver trips to the CBD. This compares with 17.4 percent in 1948.

The relationship between distance and the proportion of intra-area automobile-driver trips destined to the CBD remained the same during the period between 1948 and 1955; as distance from the CBD increased, the percentage of total intra-area automobile-driver trips destined to the CBD decreased (Table 12). The percentage from each ring, however, was less in 1955 than in 1948.

The volume of automobile-driver trips to the CBD made by residents 6 to 8 miles from the CBD varies greatly for both years from those made by residents within 8 to 10 miles of the central area. Residents of both rings, however, made approximately the same percentage of their total intra-area automobile-driver trips to the CBD, 7.0 and 7.4 percent in 1948, and 5.1 and 5.0 percent in 1955.

With respect to the purposes for which residents made automobile-driver trips to the CBD, there was a general shift in the relative importance of work and "other" trips (Table 8). The proportion of residents automobile-driver trips destined to the CBD for "other" purposes increased in each ring between 1948 and 1955, while the percentage for work decreased. By 1955, the percentage for "other" purposes had increased in the first two rings so that it was the principal purpose for residents within a 2-mile radius and ranked second for residents in the 2- to 4-mile ring. Work trips remained the dominant purpose for residents beyond 4 miles of the central area.

### Automobile Passengers

The distribution pattern of residents automobile-passenger trips to the CBD in 1948 and 1955 was similar to that of automobile-driver trips to the CBD (Table 10 and Figure 15). A comparison of the change ratio for automobile-driver and automobile-passenger trips (Table 12), however, shows that the proportion of residents automobile-passenger trips to the CBD changed less between 1948 and 1955 than did the proportion of automobile-driver trips.

The major difference in the purpose distribution was that automobile-passenger work trips had become even more common in 1955 than they had been in 1948. Residents beyond 2 miles of the CBD made 63 percent or more of their total automobile-passenger trips to the CBD in 1955 for purposes of work. In the area beyond 6 miles, approximately 3 out of 4 residents traveling to the CBD as automobile passengers went there to work. In 1948 only residents of the 6- to 8-mile ring made over 60 percent of their automobile-passenger trips to the CBD for this purpose.

TABLE 11

NUMBER OF TRIPS PER 100 DWELLING UNITS TO THE CENTRAL BUSINESS DISTRICT IN 1948 AND 1955, CLASSIFIED ACCORDING TO MODE OF TRAVEL AND DISTANCE OF RESIDENCE FROM THE CBD

| Distances from CBD        | Automobile driver |      | Automobile passenger |      | Taxi passenger |      | Mass-transit passenger |      |
|---------------------------|-------------------|------|----------------------|------|----------------|------|------------------------|------|
|                           | 1955              | 1948 | 1955                 | 1948 | 1955           | 1948 | 1955                   | 1948 |
| 0-2 miles .....           | 9.9               | 8.9  | 6.5                  | 6.3  | 4.8            | 5.3  | 32.7                   | 53.5 |
| 2-4 miles .....           | 15.2              | 17.8 | 9.7                  | 11.2 | 3.0            | 3.4  | 29.8                   | 52.3 |
| 4-6 miles .....           | 22.2              | 22.5 | 12.5                 | 12.8 | 2.2            | 2.8  | 23.6                   | 43.1 |
| 6-8 miles .....           | 19.0              | 18.2 | 11.8                 | 10.9 | 7              | 1.5  | 12.5                   | 22.5 |
| 8-10 miles .....          | 21.9              | 21.7 | 14.6                 | 13.1 | .6             | 1.8  | 9.3                    | 13.7 |
| Average, total area ..... | 17.0              | 16.8 | 10.4                 | 10.3 | 2.7            | 3.4  | 24.7                   | 45.4 |

TABLE 12

TRIPS TO THE CENTRAL BUSINESS DISTRICT IN 1948 AND 1955,  
CLASSIFIED ACCORDING TO MODE OF TRAVEL AND DISTANCE OF  
RESIDENCE FROM THE CBD

| Mode of travel comparisons          | 0 to 2 miles |         | 2 to 4 miles |         | 4 to 6 miles |         | 6 to 8 miles |         | 8 to 10 miles |        | Total area |         |
|-------------------------------------|--------------|---------|--------------|---------|--------------|---------|--------------|---------|---------------|--------|------------|---------|
|                                     | 1955         | 1948    | 1955         | 1948    | 1955         | 1948    | 1955         | 1948    | 1955          | 1948   | 1955       | 1948    |
| <b>Automobile driver trips</b>      |              |         |              |         |              |         |              |         |               |        |            |         |
| Total intra-area trips              | 96,933       | 65,207  | 243,930      | 191,562 | 402,803      | 232,776 | 305,297      | 110,909 | 106,292       | 28,326 | 1,158,255  | 628,780 |
| Trips to CBD                        | 10,431       | 7,990   | 20,978       | 19,315  | 29,859       | 19,345  | 18,787       | 7,763   | 5,285         | 2,098  | 82,340     | 56,481  |
| Percentage of trips to CBD          | 10.8         | 12.2    | 8.6          | 10.1    | 7.4          | 8.3     | 6.1          | 7.0     | 5.0           | 7.4    | 7.1        | 9.0     |
| 1955 percentage/1948 percentage     | 89           |         | 85           |         | 89           |         | 73           |         | 69            |        | 79         |         |
| 1955 trips to CBD/1948 trips to CBD | 1.31         |         | 1.09         |         | 1.54         |         | 2.03         |         | 2.52          |        | 1.46       |         |
| <b>Automobile passenger trips</b>   |              |         |              |         |              |         |              |         |               |        |            |         |
| Total intra-area trips              | 57,770       | 41,676  | 132,184      | 110,496 | 195,841      | 127,611 | 152,354      | 62,056  | 52,866        | 14,304 | 591,015    | 356,143 |
| Trips to CBD                        | 6,846        | 5,612   | 13,407       | 12,137  | 16,890       | 11,055  | 9,763        | 4,648   | 3,537         | 1,264  | 50,443     | 34,716  |
| Percentage of trips to CBD          | 11.9         | 13.5    | 10.1         | 11.0    | 8.6          | 8.7     | 6.4          | 7.5     | 6.7           | 8.8    | 8.5        | 9.7     |
| 1955 percentage/1948 percentage     | 88           |         | 92           |         | 99           |         | 85           |         | 76            |        | 88         |         |
| 1955 trips to CBD/1948 trips to CBD | 1.22         |         | 1.10         |         | 1.53         |         | 2.10         |         | 2.80          |        | 1.45       |         |
| <b>Taxi passenger trips</b>         |              |         |              |         |              |         |              |         |               |        |            |         |
| Total intra-area trips              | 20,986       | 17,653  | 18,624       | 16,888  | 11,100       | 8,873   | 5,983        | 2,416   | 1,403         | 648    | 58,096     | 46,476  |
| Trips to CBD                        | 5,018        | 4,704   | 4,140        | 3,692   | 2,988        | 2,387   | 570          | 619     | 155           | 171    | 12,871     | 11,573  |
| Percentage of trips to CBD          | 23.9         | 26.6    | 22.2         | 21.9    | 26.9         | 26.9    | 9.5          | 25.6    | 11.0          | 26.5   | 22.2       | 24.9    |
| 1955 percentage/1948 percentage     | 90           |         | 1.01         |         | 1.00         |         | 37           |         | 42            |        | 89         |         |
| 1955 trips to CBD/1948 trips to CBD | 1.07         |         | 1.12         |         | 1.25         |         | 92           |         | 91            |        | 1.11       |         |
| <b>Mass-transit passenger trips</b> |              |         |              |         |              |         |              |         |               |        |            |         |
| Total intra-area trips              | 168,109      | 215,110 | 200,877      | 245,270 | 164,548      | 164,312 | 70,122       | 47,036  | 18,026        | 6,470  | 621,682    | 678,198 |
| Trips to CBD                        | 34,507       | 47,798  | 41,043       | 56,794  | 31,812       | 37,095  | 10,385       | 9,556   | 2,288         | 1,325  | 120,005    | 152,588 |
| Percentage of trips to CBD          | 20.5         | 22.2    | 20.4         | 23.2    | 19.3         | 22.6    | 14.8         | 20.3    | 12.5          | 20.5   | 19.3       | 22.5    |
| 1955 percentage/1948 percentage     | 92           |         | .88          |         | .85          |         | 73           |         | 61            |        | 86         |         |
| 1955 trips to CBD/1948 trips to CBD | .72          |         | .72          |         | .86          |         | 1.09         |         | 1.70          |        | .79        |         |

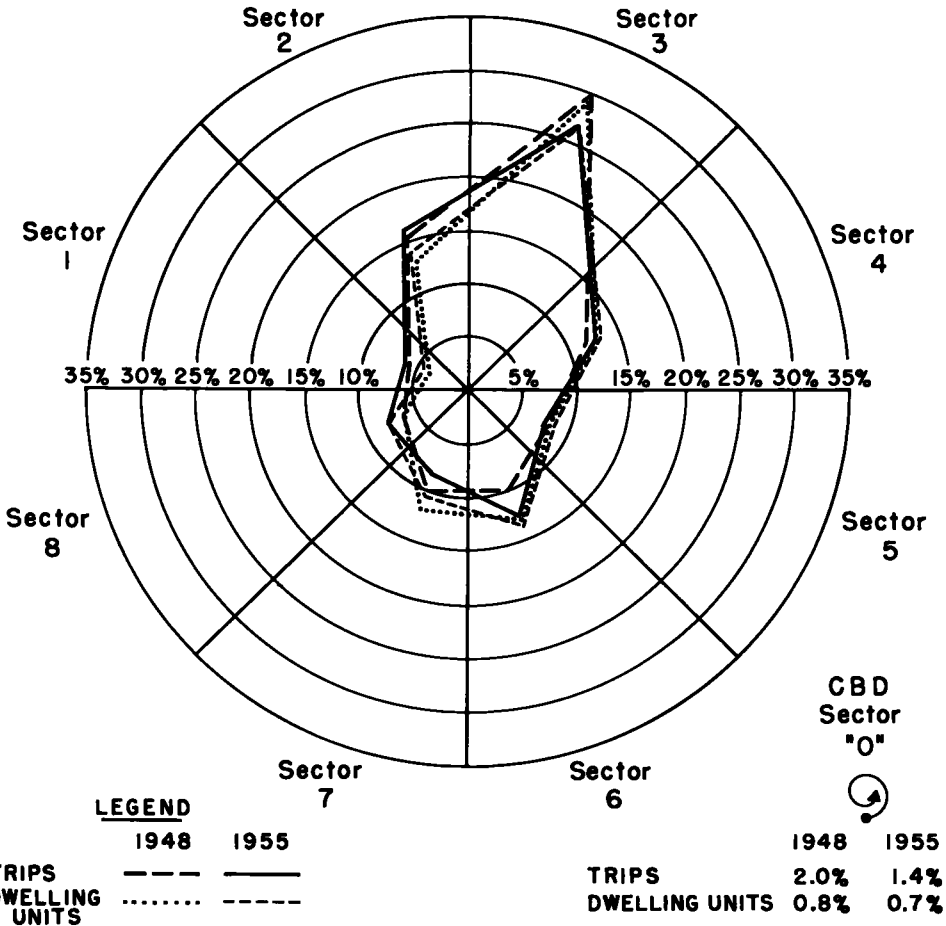

Figure 16. Percentage distribution of trips to the central business district of Washington, D.C. compared to that of dwelling units, by sectors of residence average weekday-1948 and 1955.





number of trips per dwelling unit by automobile driver, automobile passenger, and taxi passenger changed only slightly, trips by mass transit accounted for the major proportion of the decrease within each ring. When residents changed their mode of travel to the CBD, it was usually a change from mass-transit to one of the other modes.

In both years, as distance from the CBD increased, there was a progressive decrease in the number of mass transit passenger trips per dwelling unit. This was in contrast to automobile-driver and automobile-passenger trips (Table 11).

A change did occur in the relationship of distance and the percentage of residents intra-area mass-transit passenger trips destined to the CBD (Table 12). In 1948, about the same proportion of CBD trips to total area trips was found for each 2-mile ring. By 1955, however, the proportion of residents mass-transit passenger trips destined to the CBD was progressively smaller with increased distance.

Work trips in both years accounted for the major proportion of mass-transit passenger trips to the CBD (Table 8), and the proportion increased for each ring between 1948 and 1955. In contrast, the proportion of mass-transit shopping trips to the CBD decreased for each ring except for the area closest to the CBD.

### ANALYSIS OF DIRECTION FACTOR

The sector subdivisions used in this study are much like a watershed of a stream. In general, along these sector divisions flow the major inbound and outbound CBD traffic. As a result, the radial patterns of traffic provide still another means, besides distance, in analyzing the characteristics of travel to the CBD.

In the study of sectors, a different approach is taken from that used in the study of rings. The variation in distances from the CBD was the major criterion for interpreting much of the information in the ring analysis. In the study of sectors, the radial growth and distribution of population, socioeconomic characteristics and historical trends come into play in influencing the patterns that develop and the changes which take place. It has been said that "... the different types of residential areas tend to grow outward along rather distinct radii, and new growth on the arc of a given sector tends to take on the character of the initial growth in that sector...."<sup>5</sup>

Although there was a shifting between sectors, there were no major changes in the over-all pattern of residents CBD trip distribution by sectors as there had been by 2-mile rings (Table 13). The percentage of trips to the CBD from 7 of the 9 sectors varied no more than  $\pm 1.6$  percentage points from what it had been in 1948, and even though the percentage of CBD trips made by residents of sector 3 decreased slightly due to the relative increases in the other sectors, the major peak in residents trip distribution remained in sector 3.

This pattern of distribution and the relative changes which took place between the two years are very similar to that which occurred for population and dwelling units, and it suggests a close relationship between the distribution of residents trips to the CBD and the distribution of residential development (Figure 16). It did not necessarily follow, however, that residents of a sector with a large number of trips to the CBD per dwelling unit also made a large percentage of all residents CBD trips (Tables 13 and 14). It was not only the number of trips per dwelling unit that affected the pattern of distribution, but also the amount of residential development.

A change did appear to be taking place in the travel pattern of certain groups of contiguous sectors, which in 1948 had practically the same percentage of total trips destined to the CBD (Table 15). In 1948 the percentage of CBD trips made by residents of sectors 1, 2, and 3 ranged from 16.0 to 16.4 percent; that by residents of sectors 4, 5, and 6 ranged from 13.5 to 14.3 percent; and that by residents of sectors 7 and 8 ranged from 12.3 to 12.5 percent. By 1955, all the percentages had decreased, and the decrease was such that the range between percentages for these sector groups was somewhat larger than in 1948.

<sup>5</sup> The Structure and Growth of Residential Neighborhoods in American Cities. Federal Housing Administration, Washington, D. C., 1939, p. 114.

**TABLE 14**  
**NUMBER OF TRIPS PER 100 DWELLING UNITS TO THE CENTRAL**  
**BUSINESS DISTRICT IN 1948 AND 1955, CLASSIFIED ACCORDING TO**  
**PURPOSE AND SECTOR OF RESIDENCE**

| Sectors                   | Work trips |      | Shopping trips |      | Other trips |       | All purposes |       |
|---------------------------|------------|------|----------------|------|-------------|-------|--------------|-------|
|                           | 1955       | 1948 | 1955           | 1948 | 1955        | 1948  | 1955         | 1948  |
| 0 -----                   | 15.4       | 32.9 | 4.9            | 4.0  | 91.9        | 148.0 | 112.2        | 184.9 |
| 1 -----                   | 47.5       | 61.1 | 7.8            | 17.3 | 24.1        | 40.3  | 79.4         | 118.8 |
| 2 -----                   | 40.2       | 51.3 | 6.7            | 13.0 | 17.1        | 25.6  | 64.1         | 89.9  |
| 3 -----                   | 34.2       | 49.4 | 7.3            | 10.7 | 13.8        | 17.8  | 55.3         | 77.9  |
| 4 -----                   | 31.5       | 41.6 | 6.6            | 11.0 | 13.6        | 16.3  | 51.8         | 68.9  |
| 5 -----                   | 27.3       | 45.3 | 7.0            | 9.6  | 13.1        | 18.3  | 47.4         | 73.3  |
| 6 -----                   | 29.3       | 33.4 | 7.5            | 9.4  | 13.1        | 16.3  | 49.9         | 59.1  |
| 7 -----                   | 27.7       | 35.8 | 3.7            | 6.5  | 12.4        | 20.7  | 43.8         | 62.9  |
| 8 -----                   | 36.7       | 48.9 | 3.6            | 6.7  | 13.6        | 18.6  | 53.9         | 74.3  |
| Average, total area ----- | 33.4       | 44.9 | 6.4            | 10.2 | 14.9        | 20.8  | 54.8         | 76.0  |

It is difficult to say whether these differences between the 1948 and 1955 pattern were due to a trend that was taking place or to chance. If, however, these differences persist or increase, they may indicate a breaking up of the groups and the beginning of new sector groupings with a similar orientation of intra-area trips destined to the CBD.

#### TRIP PURPOSES

The change in the percentage distribution of CBD trip purposes varied from sector to sector (Table 16). The over-all trend, however, was one of decreasing differences between sectors in the proportion of residents trips for work and "other" purposes. Excluding trips made by residents of sector zero, the range between the highest and the lowest percentage of CBD work trips decreased from 14.4 percent in 1948 to 10.6 percent in 1955. More striking was the decrease in the range for "other" trips, 11.1 to 5.4 percent.

Shopping trips, on the other hand, increased slightly in the percentage range among sectors. The spread among the percentages in 1948 was 6.9 percent, and in 1955 it was 8.4 percent. This characteristic of shopping trips can be attributed to the unbalanced development of commercial facilities among the sectors. An example of this is indicated by the distribution of trip purposes for residents of sectors 5 and 6. The area included by these sectors had a relatively sparse development of major commercial activity in relation to residential growth prior to the 1948 study, and comparatively few shopping concentrations had been added by 1955. The result, as indicated in Table 16, was that residents of these sectors maintained a higher percentage of their trips to the CBD for purposes of shopping than did the residents of the other sectors.

#### Work Trips

The 1955 distribution pattern among the sectors of residents work trips to the CBD varied no more than  $\pm 2.2$  percentage points in all sectors, except sector 3, from the corresponding percentage in 1948 (Table 13 and Figure 17). Although the percentage made by residents of sector 3 decreased, the large number of residents of this sector still accounted for the major peak in the pattern of work trip distribution (32.2 percent in 1948 and 27.1 percent in 1955).

Figure 18 shows the relationship between the number of CBD work trips per 100 dwelling units of a sector in 1948 and 1955 and the number of employment opportunities per 100 dwelling units in that sector. With some exceptions, the general trend in each of the years was for the number of CBD work trips per 100 dwelling units to decrease as the number of employment opportunities per 100 dwelling units in a given sector increased. Employees tend to work at locations closer to their place of residence if

there is an opportunity to do so, or conversely, they tend to live in the vicinity of their work.

In comparing the positions of the plotted symbols in Figure 18 for the two years, it is seen that for a given sector the plotted symbols for 1955 fall to the left of those for 1948, except in the case of sector 7. The reason for this relation is that the rate of residential development in each of the sectors except sector 7 exceeded the rate of growth in employment opportunities in the corresponding sector.

The percentage of residents intra-area work trips destined to the CBD decreased in all sectors with the exception of sector 1 (Table 15). The amount of decrease varied with each sector, resulting in a new geographic relationship between sectors 1 through 5. Beginning with sector 1 and following around the central area through sector 5, it is apparent that there was a continual decrease between sectors in the proportion of 1955 intra-area work trips destined to the CBD. Although there are exceptions, this transition appears to be one from sectors with high average family incomes and with a large proportion of professional and white-collar employees to one of lower average family incomes and a large proportion of blue-collar employees. Thus, there is an indirect inference that an increasing number of employment opportunities were afforded blue-collar employees outside the CBD in 1955.

The increase in automobile ownership caused a decline in the proportion of mass-transit work trips made by sector residents (Tables 17 and 18). For example, in both 1948 and 1955 the average number of automobiles owned per 100 dwelling units by residents of sectors 0, 3, 5, and 6 was below the study area average. On the other hand, the percentage of work trips by mass transit for residents of each of these sectors was well above the average. As the number of automobiles owned per dwelling unit increased between 1948 and 1955 in all sectors, except sector zero, there was a decrease, with the exception of sectors 0 and 1, in the proportion of work trips by mass transit and a corresponding increase in those by automobile.

TAB

TRIPS TO THE CENTRAL BUSINESS DISTRICT IN 1948 AND  
RESI

| Trip purpose comparisons                    | Sector 0 |       | Sector 1 |        | Sector 2 |         | Sector 3 |         |
|---|----------|-------|----------|--------|----------|---------|----------|---------|
|   | 1955     | 1948  | 1955     | 1948   | 1955     | 1948    | 1955     | 1948    |
| <b>Work trips:</b>                          |          |       |          |        |          |         |          |         |
| Total intra-area trips.....                 | 1,662    | 2,127 | 27,354   | 21,940 | 73,913   | 54,815  | 150,000  | 135,349 |
| Trips to CBD.....                           | 511      | 911   | 10,581   | 8,071  | 27,075   | 22,952  | 43,895   | 48,609  |
| Percentage of trips to the CBD..            | 30.7     | 42.8  | 38.7     | 36.8   | 36.6     | 41.9    | 29.2     | 35.9    |
| 1955 percentage/1948 percentage..           | .72      | ----- | 1.05     | -----  | .87      | -----   | .81      | -----   |
| 1955 trips to CBD/1948 trips to<br>CBD..... | .56      | ----- | 1.31     | -----  | 1.18     | -----   | .90      | -----   |
| <b>Shopping trips:</b>                      |          |       |          |        |          |         |          |         |
| Total intra-area trips.....                 | 544      | 156   | 12,242   | 7,287  | 31,426   | 20,334  | 36,848   | 24,597  |
| Trips to CBD.....                           | 163      | 112   | 1,745    | 2,289  | 4,476    | 5,816   | 9,354    | 10,570  |
| Percentage of trips to the CBD..            | 30.0     | 71.8  | 14.3     | 31.4   | 14.2     | 28.6    | 25.4     | 43.0    |
| 1955 percentage/1948 percentage..           | .42      | ----- | .46      | -----  | .50      | -----   | .59      | -----   |
| 1955 trips to CBD/1948 trips to<br>CBD..... | 1.46     | ----- | .76      | -----  | .77      | -----   | .88      | -----   |
| <b>Other trips:</b>                         |          |       |          |        |          |         |          |         |
| Total intra-area trips.....                 | 4,172    | 5,490 | 93,861   | 66,189 | 255,963  | 176,614 | 377,695  | 314,107 |
| Trips to CBD.....                           | 3,054    | 4,094 | 5,365    | 5,321  | 11,531   | 11,427  | 17,691   | 17,524  |
| Percentage of trips to the CBD..            | 73.2     | 74.6  | 5.7      | 8.0    | 4.5      | 6.5     | 4.7      | 5.6     |
| 1955 percentage/1948 percentage..           | .98      | ----- | .71      | -----  | .69      | -----   | .84      | -----   |
| 1955 trips to CBD/1948 trips to<br>CBD..... | .75      | ----- | 1.01     | -----  | 1.01     | -----   | 1.01     | -----   |
| <b>All purposes:</b>                        |          |       |          |        |          |         |          |         |
| Total intra-area trips.....                 | 6,378    | 7,773 | 133,457  | 95,416 | 361,302  | 251,763 | 564,633  | 474,053 |
| Trips to CBD.....                           | 3,728    | 5,117 | 17,691   | 15,681 | 43,082   | 40,195  | 70,940   | 76,703  |
| Percentage of trips to the CBD..            | 58.5     | 65.8  | 13.3     | 16.4   | 11.9     | 16.0    | 12.6     | 16.2    |
| 1955 percentage/1948 percentage..           | .89      | ----- | .81      | -----  | .74      | -----   | .78      | -----   |
| 1955 trips to CBD/1948 trips to<br>CBD..... | .73      | ----- | 1.13     | -----  | 1.07     | -----   | .92      | -----   |

### Shopping Trips

The distribution pattern of sector residents shopping trips to the CBD in 1955 did not change materially from that in 1948 (Table 13 and Figure 17); six of the sectors had a change within  $\pm 1.5$  percentage points. The largest relative change, an approximate 4 percent increase, took place in sector 6, and was caused by a population increase of approximately 53,000 persons, the second largest increase in the study area. The residents of sector 6 were not served as adequately by major suburban shopping facilities as were other sectors. With few new commercial developments in this sector between 1948 and 1955, and with the large increase in population, there was an increase in the number of CBD trips.

The number of commercial concentrations increased in the various sectors, and thus contributed in part to the decrease in the number of shopping trips per dwelling unit. The increasing uniformity of CBD shopping trips by sector residents illustrates, however, that the central area continued to offer certain shopping advantages that were not satisfied elsewhere (Table 14). If residents trips of sectors 0, 7, and 8 are excluded, the range between the sector with the greatest number of shopping trips per dwelling unit and the sector with the least number was only 1.2 trips. In 1948 the range was 7.9 trips.

Although the actual volume of intra-area shopping trips increased between 1948 and 1955, it is apparent from the change ratio (Table 15) that the orientation of these trips by residents of each sector had changed significantly. The percentage of intra-area shopping trips to the CBD in 1955 decreased by one-third for residents in all sectors, and for residents in six of the sectors the percentage decreased by one-half or more.

Shopping trips for the two years by residents of sector 8 illustrate an extreme of this decreasing percentage of intra-area trips to the CBD. This sector is relatively more suburban in character than many of the other sectors at similar distances from the CBD. In 1948, 1,497 or 15.6 percent of 9,586 shopping trips by residents of sector

LE 15

1955, CLASSIFIED ACCORDING TO PURPOSE AND SECTOR OF DENCE

| Sector 4 |         | Sector 5 |         | Sector 6 |         | Sector 7 |         | Sector 8 |         | Total area |           |
|----------|---------|----------|---------|----------|---------|----------|---------|----------|---------|------------|-----------|
| 1955     | 1948    | 1955     | 1948    | 1955     | 1948    | 1955     | 1948    | 1955     | 1948    | 1955       | 1948      |
| 85,549   | 66,587  | 51,641   | 40,752  | 72,810   | 51,684  | 58,006   | 45,624  | 54,358   | 33,316  | 575,383    | 452,194   |
| 20,067   | 17,842  | 11,426   | 12,580  | 19,520   | 14,744  | 14,393   | 14,310  | 14,624   | 10,867  | 162,092    | 150,866   |
| 23.5     | 26.8    | 21.1     | 30.8    | 26.8     | 28.5    | 24.8     | 31.4    | 26.9     | 32.6    | 28.2       | 33.4      |
| .88      | -----   | .72      | -----   | .94      | -----   | .79      | -----   | .83      | -----   | .84        | -----     |
| 1.12     | -----   | .91      | -----   | 1.32     | -----   | 1.01     | -----   | 1.35     | -----   | 1.07       | -----     |
| 23,936   | 13,302  | 12,852   | 7,631   | 19,675   | 10,242  | 25,213   | 17,025  | 29,481   | 9,598   | 192,217    | 110,160   |
| 4,223    | 4,723   | 2,947    | 2,665   | 4,995    | 4,152   | 1,913    | 2,587   | 1,419    | 1,497   | 31,235     | 34,411    |
| 17.6     | 35.5    | 22.9     | 34.9    | 25.4     | 40.5    | 7.6      | 15.2    | 4.8      | 15.6    | 16.2       | 31.2      |
| .50      | -----   | .66      | -----   | .63      | -----   | .50      | -----   | .31      | -----   | .52        | -----     |
| .89      | -----   | 1.11     | -----   | 1.20     | -----   | .74      | -----   | .95      | -----   | .91        | -----     |
| 238,828  | 139,503 | 131,616  | 93,144  | 197,096  | 122,839 | 178,191  | 138,605 | 184,026  | 90,752  | 1,661,448  | 1,147,243 |
| 8,683    | 7,009   | 5,463    | 5,083   | 8,704    | 7,187   | 6,429    | 8,287   | 5,412    | 4,129   | 72,332     | 70,061    |
| 3.6      | 5.0     | 4.2      | 5.5     | 4.4      | 5.9     | 3.6      | 6.0     | 2.9      | 4.5     | 4.4        | 6.1       |
| .72      | -----   | .75      | -----   | .75      | -----   | .60      | -----   | .64      | -----   | .72        | -----     |
| 1.24     | -----   | 1.07     | -----   | 1.21     | -----   | .78      | -----   | 1.31     | -----   | 1.03       | -----     |
| 348,313  | 219,392 | 196,109  | 141,527 | 289,581  | 184,765 | 261,410  | 201,254 | 267,865  | 133,654 | 2,429,048  | 1,709,597 |
| 32,973   | 29,574  | 19,836   | 20,308  | 33,219   | 26,083  | 22,735   | 25,184  | 21,455   | 16,493  | 265,659    | 255,338   |
| 9.5      | 13.5    | 10.1     | 14.3    | 11.5     | 14.1    | 8.7      | 12.5    | 8.0      | 12.3    | 10.9       | 14.9      |
| .70      | -----   | .71      | -----   | .82      | -----   | .70      | -----   | .65      | -----   | .73        | -----     |
| 1.11     | -----   | .98      | -----   | 1.27     | -----   | .90      | -----   | 1.30     | -----   | 1.04       | -----     |

8 were destined to the CBD. In 1955 intra-area shopping trips had increased to 29,481, but the volume to the CBD remained approximately the same as in 1948 (1,419 trips), a drop from 15.6 to 4.8 percent.

There are certain geographic factors which had a great effect on trips to the CBD by residents of Virginia, especially shopping trips. It would be well, therefore, to discuss more fully sectors 7 and 8 which make up the Virginia portion of the study area. Although 2 of the 4 bridges across the Potomac River lead directly to the CBD, there was a low orientation in the 1948 study of shopping trips to the CBD by residents of sectors 7 and 8 compared with similar trips made by residents of the other sectors (Table 15). The relatively low percentages of shopping trips to the CBD became more pronounced in 1955 as increased suburban commercial development took place.

This recent history of shopping trips by residents of sectors 7 and 8 illustrates a lesser dependency on the Washington CBD for shopping purposes than was the case for other sectors. The Potomac River, because of its restricting effect on direct travel, is a psychological as well as a physical barrier to travel by Virginians to the Washington CBD. As a result, several large commercial concentrations, such as that found in the Clarendon section of Arlington, had developed before the 1948 study, and they were

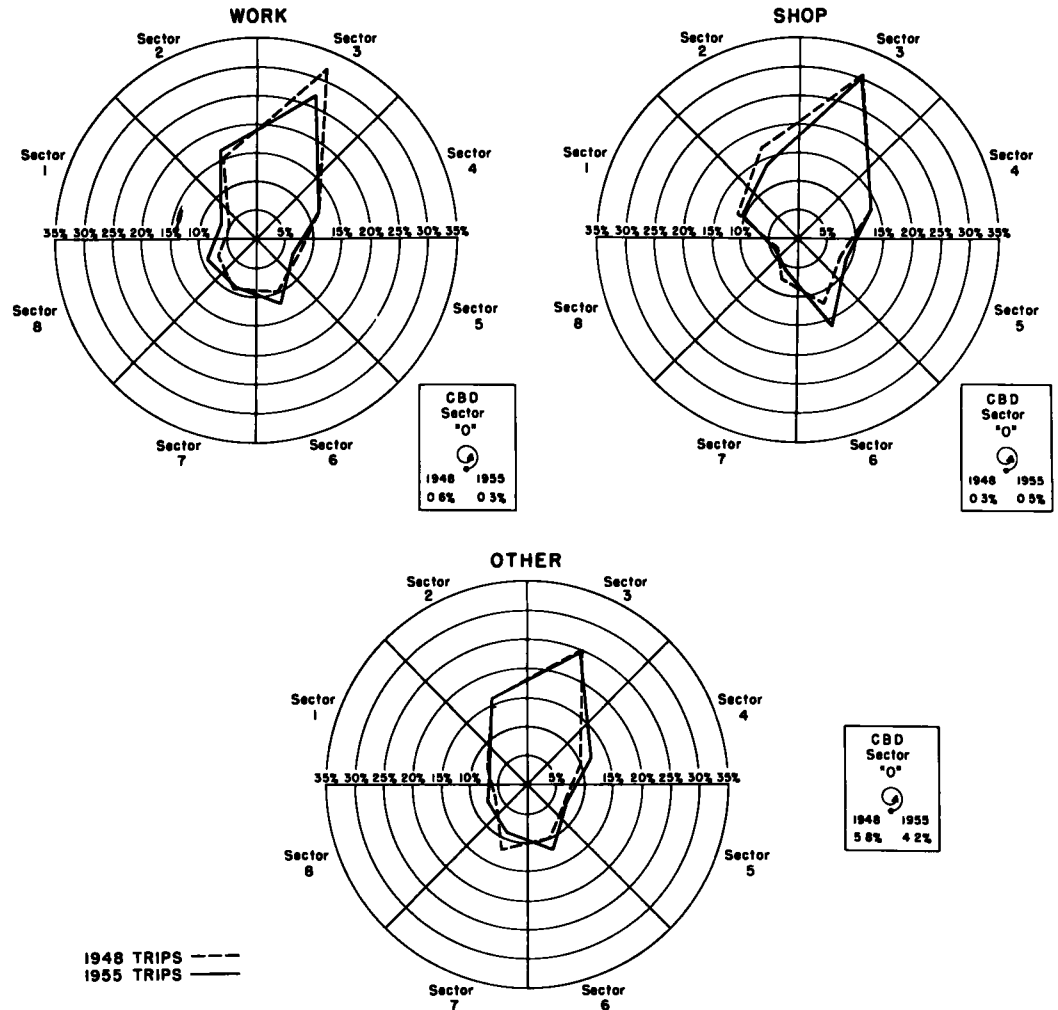

Figure 17. Percentage distribution of trips to the central business district of Washington, D.C., by purpose and sectors of residence average weekday-1948 and 1955.

servicing many of the retail needs of Virginia residents. Since that time, these centers have been greatly augmented by other regional as well as neighborhood type retail concentrations. Thus, there appeared to be an even lower orientation of shopping trips to the CBD in 1955.

The close tie that is usually considered to exist between shopping trips to the CBD and mass transit is largely substantiated by the data for 1948 (Table 18). In 1948, residents of each of the 9 sectors made 60 percent or more of their CBD shopping trips by mass transit. This relation had changed by 1955 when only sectors 3, 4, and 5 maintained as high a percentage. Even in these three sectors, the percentage was less in 1955 than it had been in 1948.

The variation between sectors in the percentage change in mode of travel might best be explained by comparing the CBD shopping trips made by residents of sectors 3 and 7. Sector 3 had convenient mass-transit service, and there was a below area average increase in automobiles owned per 100 dwelling units (24.0 percent). Between 1948 and 1955, the percentage of CBD shopping trips by mass transit decreased from 82.9 to 72.0 percent in sector 3. Even with this decrease, the percentage remained high. In contrast, trips made by residents of sector 7 changed radically. Sector 7 had a relatively less convenient mass-transit system than sector 3, but there was a very large increase in the number of automobiles per 100 dwelling units (54.0 percent). In 1948 mass transit carried nearly two-thirds (62.1 percent) of all the residents of sector 7 destined to the CBD for shopping. By 1955 the proportion was slightly more than one-third (37.5 percent).

### Other Purpose Trips

As mentioned previously in the study of distance rings, it is possible only to make generalizations of the changes that took place in the "other" trip purpose category. This group, however, did show a similarity in several characteristics that were found for work and shopping trips.

The pattern of "other" trip purpose distribution changed only slightly between 1948 and 1955. Trips by residents of 4 of the 9 sectors in 1955 were within  $\pm 0.5$  percent of the 1948 percentage, and 3 other sectors were within  $\pm 1.7$  percentage points (Table 13 and Figure 17). As in work and shopping trips, the peak trip distribution was in sector 3 which had the largest number of residents.

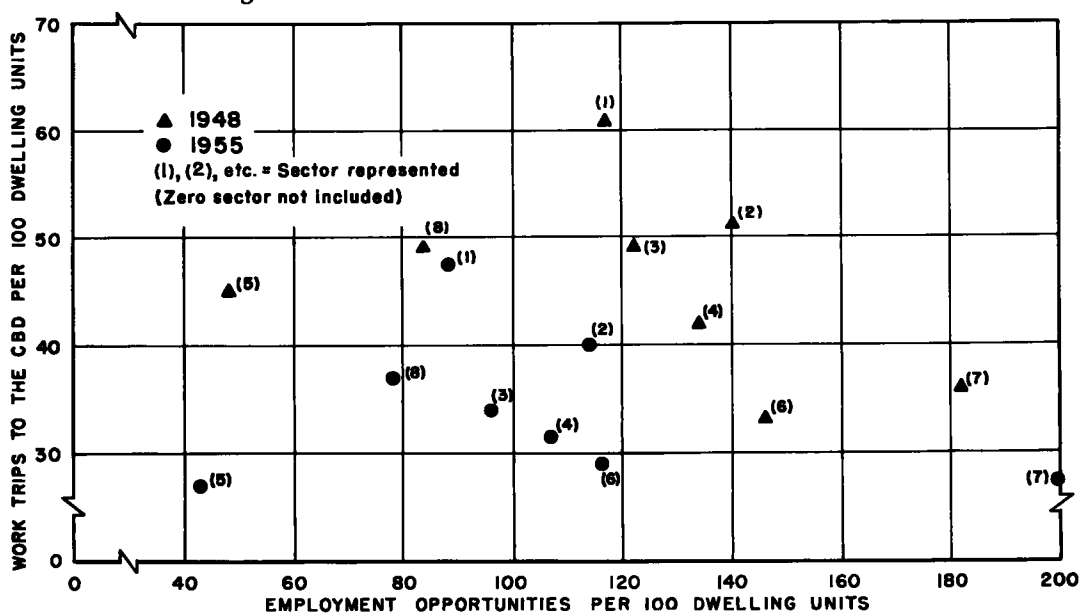

Figure 18. Relation of the number of employment opportunities to the number of work trips to the CBD per 100 dwelling units, by sectors of residence-1948 and 1955.

**PERCENTAGE DISTRIBUTION OF TRIPS TO THE CENT  
ACCORDING TO TRIP PURPOSE OF MODE**

| Trip purpose of mode of travel          | Sector 0 |       | Sector 1 |       | Sector 2 |       | Sector 3 |       |
|---|----------|-------|----------|-------|----------|-------|----------|-------|
|   | 1955     | 1948  | 1955     | 1948  | 1955     | 1948  | 1955     | 1948  |
| <b>Automobile-driver trips to—</b>      |          |       |          |       |          |       |          |       |
| Work.....                               |          | 14.2  | 54.5     | 49.1  | 55.3     | 55.3  | 50.5     | 62.5  |
| Ratio, 1955/1948.....                   |          |       | 1.11     |       | 1.00     |       | .81      |       |
| Shop.....                               |          |       | 5.9      | 8.0   | 5.9      | 6.2   | 6.2      | 6.1   |
| Ratio, 1955/1948.....                   |          |       | .74      |       | .95      |       | 1.02     |       |
| Other.....                              | 100.0    | 85.8  | 39.6     | 42.9  | 38.8     | 38.5  | 43.3     | 31.4  |
| Ratio, 1955/1948.....                   | 1.17     |       | .92      |       | 1.01     |       | 1.38     |       |
| Total.....                              | 100.0    | 100.0 | 100.0    | 100.0 | 100.0    | 100.0 | 100.0    | 100.0 |
| <b>Automobile-passenger trips to—</b>   |          |       |          |       |          |       |          |       |
| Work.....                               |          | 17.2  | 44.7     | 51.6  | 63.3     | 58.6  | 71.3     | 57.2  |
| Ratio, 1955/1948.....                   |          |       | .87      |       | 1.08     |       | 1.25     |       |
| Shop.....                               | 8.8      |       | 9.2      | 11.4  | 10.5     | 9.9   | 8.1      | 10.3  |
| Ratio, 1955/1948.....                   |          |       | .81      |       | 1.06     |       | .79      |       |
| Other.....                              | 91.2     | 82.8  | 46.1     | 37.0  | 26.2     | 31.5  | 20.6     | 32.5  |
| Ratio, 1955/1948.....                   | 1.10     |       | 1.25     |       | .83      |       | .63      |       |
| Total.....                              | 100.0    | 100.0 | 100.0    | 100.0 | 100.0    | 100.0 | 100.0    | 100.0 |
| <b>Taxi-passenger trips to—</b>         |          |       |          |       |          |       |          |       |
| Work.....                               | 21.3     | 18.1  | 60.2     | 41.5  | 60.8     | 48.8  | 58.3     | 59.8  |
| Ratio, 1955/1948.....                   | 1.18     |       | 1.45     |       | 1.25     |       | .98      |       |
| Shop.....                               | 7.4      |       | 9.6      | 15.2  | 4.7      | 12.6  | 15.6     | 8.4   |
| Ratio, 1955/1948.....                   |          |       | .63      |       | .37      |       | 1.86     |       |
| Other.....                              | 71.3     | 81.9  | 30.2     | 43.3  | 34.5     | 38.6  | 26.1     | 31.8  |
| Ratio, 1955/1948.....                   | .87      |       | .70      |       | .89      |       | .82      |       |
| Total.....                              | 100.0    | 100.0 | 100.0    | 100.0 | 100.0    | 100.0 | 100.0    | 100.0 |
| <b>Mass-transit passenger trips to—</b> |          |       |          |       |          |       |          |       |
| Work.....                               | 17.7     | 18.5  | 69.9     | 54.5  | 68.9     | 58.8  | 64.7     | 64.6  |
| Ratio, 1955/1948.....                   | .96      |       | 1.28     |       | 1.17     |       | 1.00     |       |
| Shop.....                               | 3.4      | 3.2   | 13.0     | 20.3  | 15.0     | 19.6  | 17.7     | 16.4  |
| Ratio, 1955/1948.....                   | 1.06     |       | .64      |       | .77      |       | 1.08     |       |
| Other.....                              | 78.9     | 78.3  | 17.1     | 25.2  | 16.1     | 21.6  | 17.6     | 19.0  |
| Ratio, 1955/1948.....                   | 1.01     |       | .68      |       | .75      |       | .93      |       |
| Total.....                              | 100.0    | 100.0 | 100.0    | 100.0 | 100.0    | 100.0 | 100.0    | 100.0 |
| <b>All modes of travel to—</b>          |          |       |          |       |          |       |          |       |
| Work.....                               | 13.7     | 17.8  | 59.8     | 51.5  | 62.8     | 57.1  | 61.9     | 63.4  |
| Ratio, 1955/1948.....                   | .77      |       | 1.16     |       | 1.10     |       | .98      |       |
| Shop.....                               | 4.4      | 2.2   | 9.9      | 14.6  | 10.4     | 14.5  | 13.2     | 13.8  |
| Ratio, 1955/1948.....                   | 2.00     |       | .68      |       | .72      |       | .96      |       |
| Other.....                              | 81.9     | 80.0  | 30.3     | 33.9  | 26.8     | 28.4  | 24.9     | 22.8  |
| Ratio, 1955/1948.....                   | 1.02     |       | .89      |       | .94      |       | 1.09     |       |
| Total.....                              | 100.0    | 100.0 | 100.0    | 100.0 | 100.0    | 100.0 | 100.0    | 100.0 |

The number of "other" purpose trips to the CBD per 100 dwelling units decreased for residents of all sectors (Table 14), and the trend was toward greater uniformity in the distribution of trips per dwelling unit between each of the sectors, particularly sectors 3 through 8.

The distribution of modes of travel by which "other" purpose trips were made indicates a large increase in the percentage of trips by automobile drivers for each sector between 1948 and 1955 (Table 18). Here again, this change in mode of travel was apparently due to an increase in the automobile ownership ratio. In 1948 residents of only two sectors, 1 and 8, made 40 percent or more of their CBD "other" purpose trips as automobile drivers. At that time, these two sectors contained the largest number of automobiles per dwelling unit. With an increase in the number of automobiles owned, residents of each sector in 1955, except sector zero, made 40 percent or more of their "other" purpose trips as automobile drivers.

#### MODES OF TRAVEL

In 1948 and 1955, there was an inverse relationship between automobile ownership and the percentage of residents CBD trips made by mass-transit passengers. If the sectors are listed in accordance with automobiles owned per 100 dwelling units from



LE 16

**RAL BUSINESS DISTRICT IN 1948 AND 1955, CLASSIFIED  
OF TRAVEL AND SECTOR OF RESIDENCE**

| Sector 4 |       | Sector 5 |       | Sector 6 |       | Sector 7 |       | Sector 8 |       | Total area |       |
|----------|-------|----------|-------|----------|-------|----------|-------|----------|-------|------------|-------|
| 1955     | 1948  | 1955     | 1948  | 1955     | 1948  | 1955     | 1948  | 1955     | 1948  | 1955       | 1948  |
| 52.4     | 60.1  | 44.6     | 54.3  | 44.4     | 56.7  | 53.1     | 46.7  | 56.0     | 59.2  | 51.2       | 55.9  |
| .87      | ---   | .82      | ---   | .78      | ---   | 1.14     | ---   | .95      | ---   | .92        | ---   |
| 8.3      | 7.0   | 12.1     | 7.5   | 10.1     | 7.5   | 7.5      | 8.7   | 4.2      | 5.1   | 7.2        | 6.8   |
| 1.19     | ---   | 1.61     | ---   | 1.35     | ---   | .86      | ---   | .82      | ---   | 1.06       | ---   |
| 39.3     | 32.9  | 43.3     | 38.2  | 45.5     | 35.8  | 39.4     | 44.6  | 39.8     | 35.7  | 41.6       | 37.3  |
| 1.20     | ---   | 1.13     | ---   | 1.27     | ---   | .88      | ---   | 1.12     | ---   | 1.12       | ---   |
| 100.0    | 100.0 | 100.0    | 100.0 | 100.0    | 100.0 | 100.0    | 100.0 | 100.0    | 100.0 | 100.0      | 100.0 |
| 72.8     | 52.0  | 72.7     | 57.1  | 63.0     | 51.4  | 62.9     | 51.4  | 73.2     | 66.2  | 66.2       | 55.1  |
| 1.40     | ---   | 1.27     | ---   | 1.23     | ---   | 1.22     | ---   | 1.11     | ---   | 1.20       | ---   |
| 6.8      | 14.6  | 10.4     | 13.7  | 14.2     | 11.1  | 7.6      | 8.2   | 5.1      | 6.0   | 8.9        | 10.3  |
| .47      | ---   | .76      | ---   | 1.28     | ---   | .93      | ---   | .85      | ---   | .86        | ---   |
| 20.4     | 33.4  | 16.9     | 29.2  | 22.8     | 37.5  | 29.5     | 40.4  | 21.7     | 27.8  | 24.9       | 34.6  |
| .61      | ---   | .58      | ---   | .61      | ---   | .73      | ---   | .78      | ---   | .72        | ---   |
| 100.0    | 100.0 | 100.0    | 100.0 | 100.0    | 100.0 | 100.0    | 100.0 | 100.0    | 100.0 | 100.0      | 100.0 |
| 36.6     | 57.1  | 64.2     | 38.3  | 57.9     | 17.0  | 22.0     | 41.7  | 56.3     | 60.0  | 54.7       | 48.8  |
| .64      | ---   | 1.68     | ---   | 3.41     | ---   | .53      | ---   | .94      | ---   | 1.12       | ---   |
| 16.9     | 28.6  | 17.9     | 26.0  | 19.6     | 10.3  | 24.6     | ---   | 12.5     | ---   | 17.3       | 11.4  |
| .59      | ---   | .69      | ---   | 1.90     | ---   | ---      | ---   | ---      | ---   | 1.08       | ---   |
| 46.5     | 14.3  | 17.9     | 35.7  | 22.5     | 72.7  | 53.4     | 58.3  | 31.2     | 40.0  | 33.0       | 39.8  |
| 3.25     | ---   | .50      | ---   | .31      | ---   | .92      | ---   | .78      | ---   | .83        | ---   |
| 100.0    | 100.0 | 100.0    | 100.0 | 100.0    | 100.0 | 100.0    | 100.0 | 100.0    | 100.0 | 100.0      | 100.0 |
| 63.0     | 62.7  | 60.4     | 66.3  | 66.3     | 59.0  | 77.6     | 65.4  | 81.6     | 72.1  | 66.2       | 62.0  |
| 1.01     | ---   | .91      | ---   | 1.12     | ---   | 1.19     | ---   | 1.13     | ---   | 1.07       | ---   |
| 19.0     | 19.4  | 17.8     | 13.7  | 18.2     | 20.1  | 9.0      | 12.6  | 10.8     | 14.8  | 16.0       | 16.8  |
| .98      | ---   | 1.30     | ---   | .91      | ---   | .71      | ---   | .73      | ---   | .95        | ---   |
| 18.0     | 17.9  | 21.8     | 20.0  | 15.5     | 20.9  | 13.4     | 22.0  | 7.6      | 13.1  | 17.8       | 21.2  |
| 1.01     | ---   | 1.09     | ---   | .74      | ---   | .61      | ---   | .58      | ---   | .84        | ---   |
| 100.0    | 100.0 | 100.0    | 100.0 | 100.0    | 100.0 | 100.0    | 100.0 | 100.0    | 100.0 | 100.0      | 100.0 |
| 60.9     | 60.3  | 57.6     | 61.9  | 58.8     | 56.5  | 63.3     | 56.8  | 68.2     | 65.9  | 61.0       | 59.1  |
| 1.01     | ---   | .93      | ---   | 1.04     | ---   | 1.11     | ---   | 1.04     | ---   | 1.03       | ---   |
| 12.8     | 16.0  | 14.9     | 13.1  | 15.0     | 15.9  | 8.4      | 10.3  | 6.6      | 9.1   | 11.8       | 13.5  |
| .80      | ---   | 1.14     | ---   | .94      | ---   | .82      | ---   | .73      | ---   | .87        | ---   |
| 26.3     | 23.7  | 27.5     | 25.0  | 26.2     | 27.6  | 28.3     | 32.9  | 25.2     | 25.0  | 27.2       | 27.4  |
| 1.11     | ---   | 1.10     | ---   | .95      | ---   | .86      | ---   | 1.01     | ---   | .99        | ---   |
| 100.0    | 100.0 | 100.0    | 100.0 | 100.0    | 100.0 | 100.0    | 100.0 | 100.0    | 100.0 | 100.0      | 100.0 |

the highest to the lowest and then by the percentage of residents CBD trips made by mass-transit passengers (Table 18) from the lowest to the highest, it will be seen that for both years the sequence of the sectors was nearly the same. Exceptions to this sequence were sectors 4 and 7 in 1948 and 1, 2, and 7 in 1955.

Since there was a general tendency for smaller percentages of mass-transit passenger trips to be made by residents of sectors with a greater number of automobiles owned per dwelling unit, it followed that with increased automobile ownership within each sector, with the exception of sector zero, the percentage of CBD trips by mass transit decreased. The changes which occurred within each sector in the percentage distribution of mode of travel to the CBD resulted in an increasing similarity of these percentages between sectors (Table 18).

To illustrate this increasing uniformity, residents of sectors 1 through 6 (District of Columbia and Maryland) were considered as one group, and residents of sectors 7 and 8 (Virginia) were considered as a second group. Residents of sector zero were excluded in the analysis. In the first group, the range between the sector with the smallest and that with the largest percentage of residents CBD trips by automobile drivers was 15.9 percent in 1948 and 8.0 percent in 1955. If sector 3 is omitted from the comparison, the range is 13.5 percent in 1948 and only 2.6 percent in 1955. Group 2 indicated the same trend; there was a range of 8.0 percent in 1948 and only 1.4 percent in 1955.

The range between sectors in the percentage of residents CBD trips by mass-transit passengers decreased for group 1 from 24.6 percent in 1948 to 12.5 percent in 1955; sectors in group 2 decreased from 9.7 to 5.7 percent. The range in the percentage of trips by automobile passengers decreased in the first group of sectors, but increased slightly in the second group. The range for taxi passengers remained stable between 1948 and 1955 for both groups of sectors.

**Automobile Drivers**

The percentage of intra-area automobile-driver trips destined to the CBD decreased for residents of each sector (Table 19). The largest decreases occurred for the trips by residents of sectors with the greatest number of automobiles owned per dwelling unit in 1948 and 1955, sectors 1 and 8.

The pattern of distribution of automobile-driver trips by residents of each sector varied only slightly from what it had been in 1948 (Table 20 and Figure 19), even though automobile ownership increased by various amounts in each sector with the exception

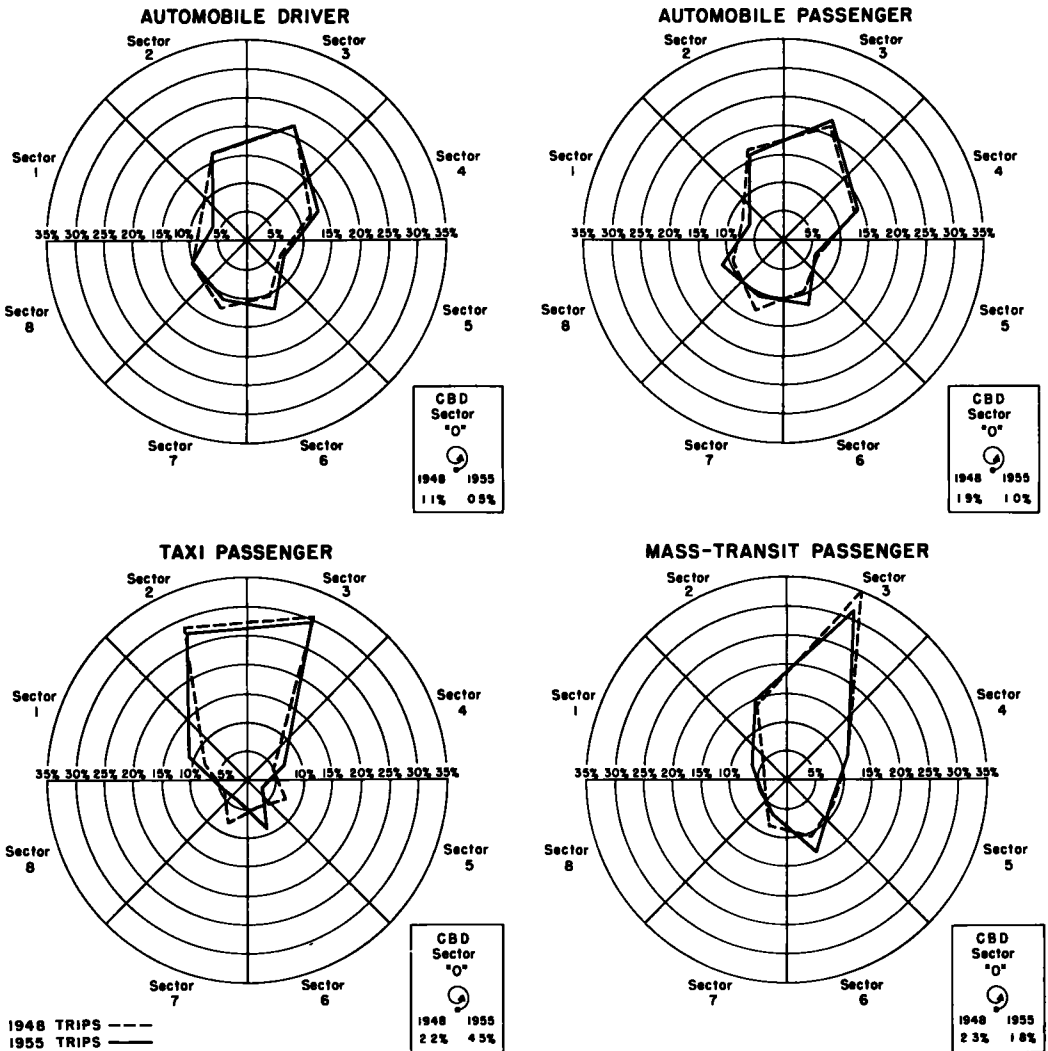

Figure 19. Percentage distribution of trips to the central business district of Washington, D.C., by mode of travel and sectors of residence average weekday-1948 and 1955.

TABLE 17

**AVERAGE ANNUAL FAMILY INCOME  
FOR 1955 AND AVERAGE NUMBER  
OF AUTOMOBILES OWNED PER  
100 DWELLING UNITS, GROUPED  
BY SECTOR OF RESIDENCE**

| Sectors                  | Average income, 1955 <sup>1</sup> | Number of automobiles owned per 100 dwelling units |      |                  |
|--------------------------|-----------------------------------|--|------|------------------|
|                          |                                   | 1955   | 1948 | Ratio, 1955/1948 |
| 0.....                   | \$4,300                           | 19   | 23   | 0.83             |
| 1.....                   | 10,100                            | 96   | 86   | 1.12             |
| 2.....                   | 9,900                             | 82   | 70   | 1.17             |
| 3.....                   | 5,600                             | 62   | 50   | 1.24             |
| 4.....                   | 5,900                             | 88   | 71   | 1.24             |
| 5.....                   | 4,800                             | 70   | 52   | 1.35             |
| 6.....                   | 5,400                             | 73   | 53   | 1.38             |
| 7.....                   | 7,200                             | 91   | 59   | 1.54             |
| 8.....                   | 8,300                             | 109  | 91   | 1.20             |
| Average, total area..... | 6,700                             | 79   | 61   | 1.30             |

<sup>1</sup> Figures for 1948 are not shown because the data for the 2 years are not comparable.

of sector zero. The percentage distribution changed within  $\pm 1.6$  percentage points of what it had been in 1948 in 7 of the sectors, and in 3 sectors the change was within  $\pm 0.2$  percent. Sector 3 still maintained the major peak of residents automobile-driver trips; however, because of the greater distribution of automobiles and the use thereof in comparison to taxis and mass transit, the peak in sector 3 is seen to be less extreme in both years than the distribution pattern of the latter two modes of travel.

With the increased number of automobiles owned per dwelling unit, there was a smaller difference between sectors in the number of automobile-driver trips to the CBD per dwelling unit (Table 21). The range between the sector with the greatest number of trips and that with the least decreased by over 50 percent in 1955 (25.3 trips in 1948 and 10.8 in 1955).

The relationship between the number of automobiles owned per dwelling unit and the percentage of intra-area automobile-driver trips destined to the CBD changed between 1948 and 1955, as shown in Figure 20. In 1948, the plotted symbols indicate no apparent trend. In 1955, however, the percentage of intra-area automobile-driver trips destined to the CBD was generally less for those sectors that had the greater number of automobiles per dwelling unit.

Although work continued to be the dominant purpose for which automobile-driver trips were made to the CBD, the change in the percentage distribution of trip purposes for each of the sectors indicated a general tendency for work trips to decrease in relative importance while "other" trips increased (Table 16). Sectors 1 and 7, the two sectors with the highest percentage of 1948 CBD automobile-driver trips made for "other" purposes, were the exceptions.

Another change which occurred was the decrease in the range of purpose distribution for work and "other" purposes between five of the sectors (Table 16). In 1948 residents of sectors 1, 2, 4, 7, and 8 had a range in the percentage of their CBD automobile-driver trips for work of 13.4 percent; for "other" purposes, it was 11.7 percent. In 1955 these ranges had decreased to 3.6 percent for work and 1.0 percent for "other" trips. It is interesting to note that these sectors also included the residents who had the highest average incomes in the study area as well as the greatest number of automobiles owned per dwelling unit.

### Automobile Passengers

The relative changes between 1948 and 1955 in the distribution pattern of sector residents CBD automobile-passenger trips were generally small (Table 20 and Figure 19); six of the sectors had a change that was within  $\pm 1.5$  percentage points of the 1948 figure. As indicated in Figure 19, the distribution of residents trips in both years showed a pattern very similar to that of automobile-driver trips; and although sector 3 contained the major peak of automobile-passenger trip distribution, as in automobile-driver trips, the peak was not so extreme as the distribution of mass-transit passenger trips.

The relative relationship between the number of automobiles owned and the number of automobile-passenger trips to the CBD per dwelling unit remained approximately







LE 19

1955, CLASSIFIED ACCORDING TO MODE OF TRAVEL AND RESIDENCE

| Sector 4 |        | Sector 5 |        | Sector 6 |        | Sector 7 |        | Sector 8 |        | Total area |         |
|----------|--------|----------|--------|----------|--------|----------|--------|----------|--------|------------|---------|
| 1955     | 1948   | 1955     | 1948   | 1955     | 1948   | 1955     | 1948   | 1955     | 1948   | 1955       | 1948    |
| 172,247  | 83,868 | 82,702   | 39,873 | 131,493  | 64,564 | 143,757  | 89,014 | 149,594  | 68,046 | 1,158,255  | 628,780 |
| 10,919   | 6,797  | 6,089    | 3,704  | 10,124   | 5,769  | 8,994    | 7,072  | 8,788    | 5,949  | 82,340     | 56,481  |
| 6.3      | 8.1    | 7.4      | 9.3    | 7.7      | 8.9    | 6.3      | 7.9    | 5.9      | 8.7    | 7.1        | 9.0     |
| .78      | -----  | .80      | -----  | .87      | -----  | .80      | -----  | .68      | -----  | .79        | -----   |
| 1.61     | -----  | 1.64     | -----  | 1.75     | -----  | 1.27     | -----  | 1.48     | -----  | 1.46       | -----   |
| 88,698   | 43,457 | 39,833   | 22,750 | 68,490   | 37,844 | 70,273   | 52,440 | 74,798   | 37,136 | 591,015    | 356,143 |
| 7,049    | 4,601  | 3,146    | 2,291  | 6,031    | 3,352  | 5,283    | 4,455  | 5,776    | 3,265  | 50,443     | 34,716  |
| 7.9      | 10.6   | 7.9      | 10.1   | 8.8      | 8.9    | 7.5      | 8.5    | 7.7      | 8.8    | 8.5        | 9.7     |
| .75      | -----  | .78      | -----  | .99      | -----  | .88      | -----  | .88      | -----  | .88        | -----   |
| 1.53     | -----  | 1.37     | -----  | 1.80     | -----  | 1.19     | -----  | 1.77     | -----  | 1.45       | -----   |
| 4,964    | 3,354  | 4,450    | 4,649  | 5,202    | 4,890  | 1,866    | 3,035  | 1,746    | 1,166  | 58,096     | 46,476  |
| 917      | 580    | 403      | 887    | 1,138    | 600    | 483      | 911    | 583      | 535    | 12,871     | 11,573  |
| 18.5     | 17.3   | 9.1      | 19.1   | 21.9     | 12.3   | 25.9     | 30.0   | 33.4     | 45.9   | 22.2       | 24.9    |
| 1.06     | -----  | .48      | -----  | 1.78     | -----  | .87      | -----  | .73      | -----  | .89        | -----   |
| 1.58     | -----  | .45      | -----  | 1.90     | -----  | .53      | -----  | 1.09     | -----  | 1.11       | -----   |
| 82,404   | 88,713 | 69,124   | 74,255 | 84,396   | 77,467 | 45,514   | 56,765 | 41,727   | 27,306 | 621,682    | 678,198 |
| 14,088   | 17,596 | 10,198   | 13,426 | 15,926   | 16,362 | 7,975    | 12,746 | 6,308    | 6,744  | 120,005    | 152,568 |
| 17.1     | 19.8   | 14.8     | 18.1   | 18.9     | 26.1   | 17.5     | 22.5   | 15.1     | 24.7   | 19.3       | 22.5    |
| .86      | -----  | .82      | -----  | .90      | -----  | .78      | -----  | .61      | -----  | .86        | -----   |
| .80      | -----  | .76      | -----  | .97      | -----  | .63      | -----  | .94      | -----  | .79        | -----   |

Although the percentage distribution of trip purposes for which CBD taxi-passenger trips were made shifted in each of the sectors, the most significant change was the decrease in the percentage of "other" purpose residents trips in 8 of the 9 sectors (Table 16). Taxi-passenger work trips increased in 5 of the 9 sectors, and in 6 of the 9 sectors, 56 percent or more of the taxi-passenger trips were to work.

TABLE 21

NUMBER OF TRIPS PER 100 DWELLING UNITS TO THE CENTRAL BUSINESS DISTRICT IN 1948 AND 1955, CLASSIFIED ACCORDING TO MODE OF TRAVEL AND SECTOR OF RESIDENCE

| Sectors                  | Automobile driver |      | Automobile passenger |      | Taxi passenger |      | Mass-transit passenger |       |
|--------------------------|-------------------|------|----------------------|------|----------------|------|------------------------|-------|
|                          | 1955              | 1948 | 1955                 | 1948 | 1955           | 1948 | 1955                   | 1948  |
| 0.....                   | 13.3              | 22.7 | 15.6                 | 23.9 | 17.4           | 9.4  | 65.8                   | 128.9 |
| 1.....                   | 24.6              | 37.6 | 14.3                 | 20.5 | 6.5            | 7.1  | 34.1                   | 53.6  |
| 2.....                   | 20.4              | 21.2 | 12.0                 | 13.1 | 5.3            | 7.4  | 26.3                   | 48.3  |
| 3.....                   | 13.8              | 12.3 | 8.9                  | 7.7  | 2.9            | 3.6  | 29.6                   | 54.3  |
| 4.....                   | 17.1              | 15.8 | 11.1                 | 10.7 | 1.4            | 1.4  | 22.1                   | 41.0  |
| 5.....                   | 14.6              | 13.4 | 7.5                  | 8.3  | 1.0            | 3.2  | 24.4                   | 48.5  |
| 6.....                   | 15.2              | 13.1 | 9.0                  | 7.6  | 1.7            | 1.4  | 23.9                   | 37.0  |
| 7.....                   | 17.3              | 17.7 | 10.2                 | 11.1 | .9             | 2.3  | 15.4                   | 31.9  |
| 8.....                   | 22.1              | 26.8 | 14.5                 | 14.7 | 1.5            | 2.4  | 15.8                   | 30.4  |
| Average, total area..... | 17.0              | 16.8 | 10.4                 | 10.3 | 2.7            | 3.4  | 24.7                   | 45.4  |

**Mass-Transit Passengers**

As in the other modes of travel, there was a shifting between sectors in the relative distribution of total residents mass-transit passenger trips to the CBD (Table 20 and Figure 19). Nevertheless, the pattern of distribution changed only slightly as 7 of the sectors were within  $\pm 2.0$  percentage points of the 1948 figure and 4 of the sectors were within  $\pm 0.5$  percent. The extremely high volume of trips made by residents of sector 3 can be attributed to the concentration of population in apartments, row houses, and boarding houses, and the relatively adequate transit service for this sector.

Unlike other modes of travel to the CBD, the number of mass-transit passenger trips per dwelling unit decreased in each sector between 1948 and 1955 (Table 21). As a result, there was a growing similarity in the number of trips per dwelling unit in all sectors. The area in which the most important decrease took place occurred between sectors 2 through 6. In 1948, the range between the sector with the greatest and that with the fewest number of mass-transit passenger trips to the CBD per dwelling unit was 17.3 trips. By 1955 the range was only 7.5. If sector 3 is excluded in the comparison, the range is 11.5 trips in 1948 and 4.2 in 1955.

Of the percentage of intra-area mass-transit trips destined to the CBD, it was found that only residents of sector 1 maintained approximately the same percentage in 1955 as in 1948 (Table 19). The relative decreases that did take place in the other sectors,

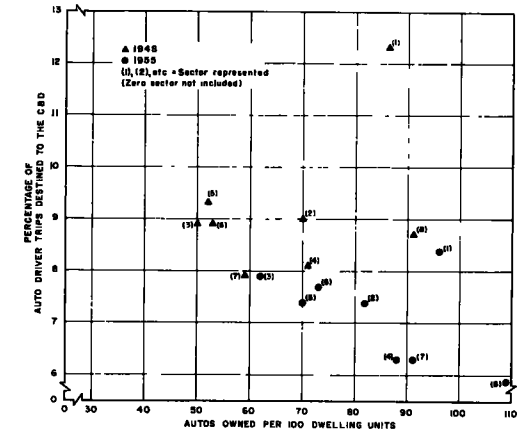

Figure 20. Relation of autos owned per 100 dwelling units to the percentage of auto driver trips destined to the CBD, by sectors of residence-1948 and 1955.

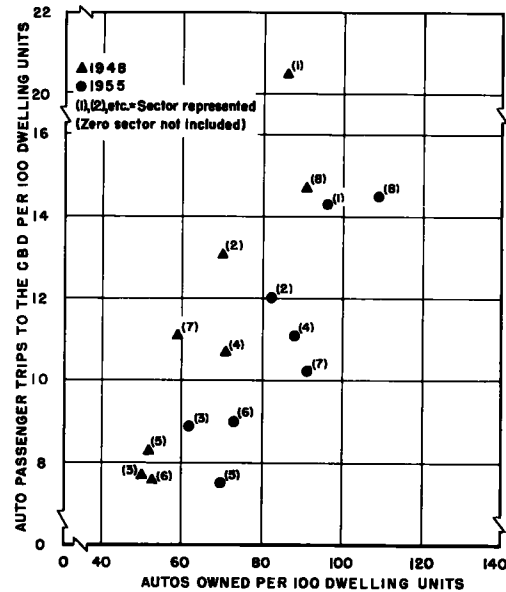

Figure 21. Relation of autos owned to the number of auto passenger trips to the CBD per 100 dwelling units, by sectors of residence-1948 and 1955.

however, appeared to have a geographical relationship with the CBD. A comparison beginning with sector 2 and moving around the CBD through sector 8, with the exception of sector 6, would show that a progressive increase in the relative changes in orientation took place between 1948 and 1955 (Table 19).

Trips to work remained the principal purpose for which sector residents made mass-transit passenger trips to the CBE (Table 16). By 1955 residents of each sector, excluding sector zero, were making 60 percent or more of their CBD mass-transit passenger trips to work. Trips made by residents of sectors 7 and 8 are especially noteworthy. By 1955 these residents of Virginia were making approximately 4 out of 5 mass-transit passenger trips for the purpose of work, which indicated the very limited use of mass transit to the CBD for all the other purposes.