

Effect of Freeway Medians on Traffic Behavior

CHARLES J. KEESE, Research Engineer, and
CHARLES PINNELL, Assistant Research Engineer,
Texas Transportation Institute, Texas A & M College System

This paper presents a portion of the material developed during a series of traffic behavior studies conducted on freeways in Texas. The research was conducted by the Texas Transportation Institute for the Texas Highway Department and was designed to obtain data which would be useful in evaluating freeway median design.

The field studies utilized the Bureau of Public Roads' electronic traffic behavior equipment which permitted the recording of data on volume, speed, and vehicle placement for each of several freeway lanes. Studies were made on six different sections of freeways located in Houston, Dallas, and Fort Worth, Texas. Approximately 50,000 observations were analyzed.

Statistical analyses were made to determine the effect of various types of median designs on traffic behavior. Vehicle placements were used as a criterion of traffic behavior and the variations in these placements were compared for various median designs.

Studies were also made before and after the erection of a barrier fence on the 4-ft median of the Gulf Freeway in Houston to determine the effect of this fence on traffic behavior. This study utilizes data obtained by use of the Bureau of Public Roads' equipment and from motion picture studies conducted by the Texas Transportation Institute.

The analysis of the data indicated that average vehicle placements did not vary greatly, but that different type and width medians had some effect on traffic behavior. The wider medians reduced the effects of opposing flows and high volumes.

● NUMEROUS TYPES of medians, differing in width and in design, have been used on existing highways in Texas and throughout the country. Although various median studies have been performed in recent years, additional information regarding the effect of freeway median design on traffic behavior was felt to be of value. The purpose of this study was to develop additional knowledge of this type.

Volume, speed, and placement data were recorded as a possible criterion of median effect on traffic behavior. These data were obtained from a number of traffic behavior studies conducted by the Bureau of Public Roads and from motion picture studies performed by personnel of the Texas Transportation Institute.

The field studies utilized the Bureau of Public Roads' electronic traffic analyzer equipment. A. Taragin of the Bureau of Public Roads

supervised the installation and operation of the equipment. Personnel of the Bureau of Public Roads and of the Texas Highway Department conducted the surveys.

Segmented placement tubes and air impulse speed tubes were placed across the pavement as shown in Figure 1. These tubes transmitted impulses to the electronic recording equipment housed in a special truck which was concealed from the motorists as shown in Figure 2. A speed meter, decimal timer, and four coding machines capable of handling any four traffic lanes were used to record time of passing, speed and placement data on each vehicle. These data were placed on punch cards and high-speed electronic computers were used in the analyses.



Figure 1. Speed trap tubes and placement tapes—Bureau of Public Roads Study.

For this study, six different sections of freeways located in or near Houston, Dallas, and Fort Worth, Texas, were selected to provide data on various designs of medians presently being used on freeways in Texas. The different types of medians studied (Figs. 3 and 4) ranged from a 4-ft concrete median to a 40-ft grassed median.

The studies performed are listed below with a brief description of median type for each study:

<u>Study</u>	<u>Location</u>	<u>Date</u>	<u>Median Type</u>	<u>Fig. No.</u>
00	Houston - Gulf Freeway	May 1958	4-ft concrete with barrier curb	4A
01	Fort Worth - East West Freeway	July 1957	12-ft asphalt with concrete barrier curb	3A
03	Dallas - Central Expressway	July 1957	12-ft concrete with mountable curb	3B

<u>Study</u>	<u>Location</u>	<u>Date</u>	<u>Median Type</u>	<u>Fig. No.</u>
04	Dallas - Central Ex- pressway	July 1957	27-ft grassed with mount- able curb	3C
05	Dallas - US 80 (rural)	July 1957	40-ft grassed, no curb	3D
07	Houston - Gulf Freeway	July 1957	4-ft concrete with barrier curb and barrier fence	4B
08	Houston - Eastex Freeway	July 1957	4-ft concrete with concrete barrier	4C

The daytime studies were conducted during the period of 7:00 A.M. to 7:00 P.M. and the night studies from 8:00 P.M. to 12:00 P.M. The data on speed, volume, and placement were tabulated by 6-min periods for each hour.

Data on average vehicle placements for all Bureau of Public Roads studies are shown in Table 1. These data include only passenger vehicles and are subdivided by lane and day-night tabulations. Placements were measured from the left lane line to the centerline of the vehicles.

The data shown in Table 1 represent a total of 46,968 observations of vehicle placements. The actual number of placement observations was greater than this but some data were invalidated by inclement weather and by unusual traffic conditions on the freeways such as accidents, stalled vehicles, etc.

The maximum variations in average placements are shown in Figures 5 and 6. These data indicate that for all of the medians studied there was a relatively small amount of variation in average vehicle placement. The average placements for the inside and middle lanes were close to the centerline of the lane with the maximum difference being 0.85 ft for the inside lane and 0.82 ft for the middle lane during the daytime. The average placements in the outside lane were generally further to the left of the lane centerline and were more variable than the inside and middle placements.

METHOD OF STUDY

Because the variations in average placements for the different type medians were relatively small, a statistical analysis was performed to study the variance of the data. With this type of analysis, it was possible to determine significant differences among the data and to infer possible conclusions from these differences. Two separate studies were made: a study to determine the effect of a barrier fence on traffic behavior and a general study to determine the effect of various width medians on traffic behavior.

After consideration of the data and the method of analysis it was decided to use only placement and volume data in the analysis. Because vehicle speeds were affected by such factors as volume, speed limits, type of area, enforcement level, etc., the application of speed data to statistical analysis was impractical in these studies. Data on average speeds are presented in Table 2 as an indication of the character of operation on each of the facilities.

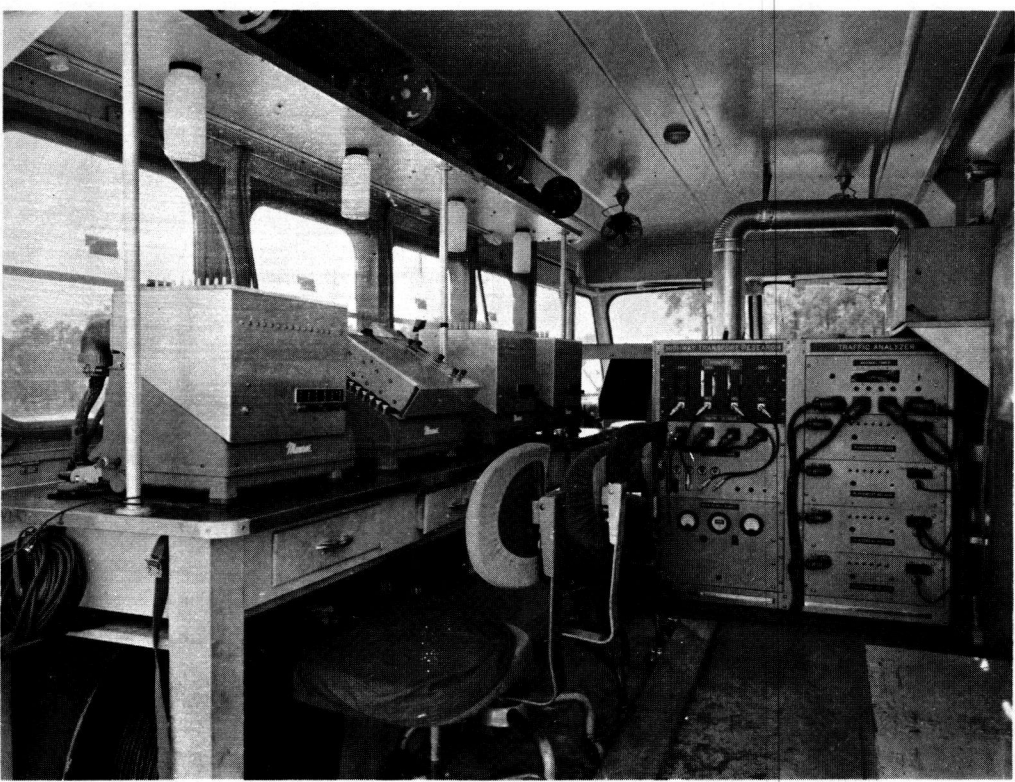
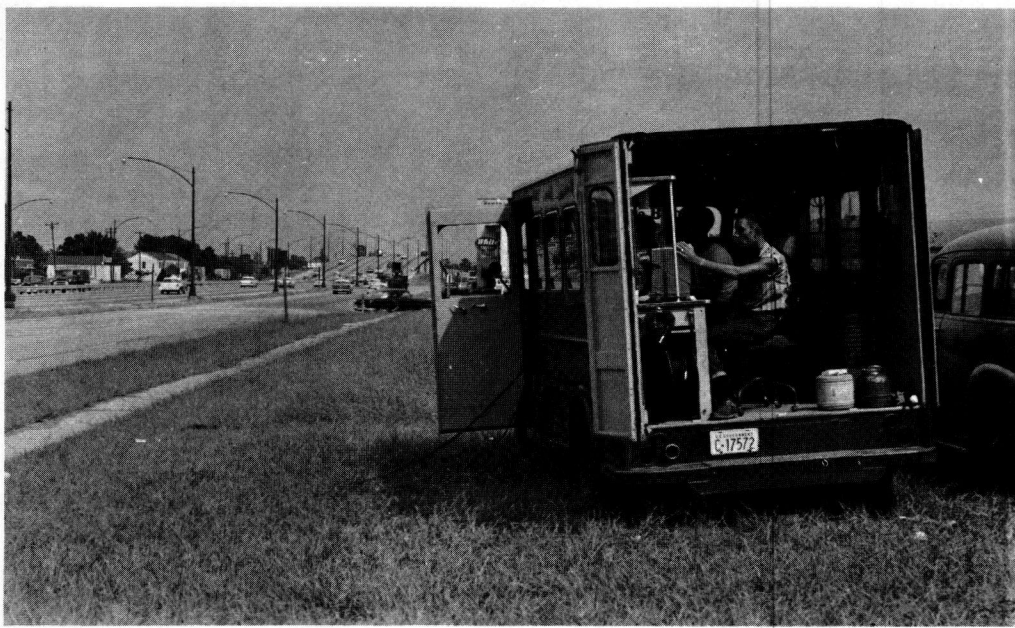
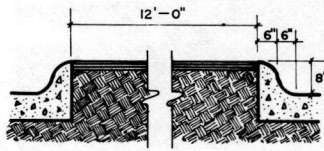
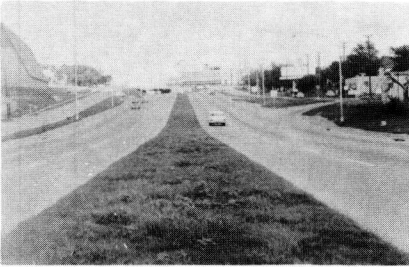
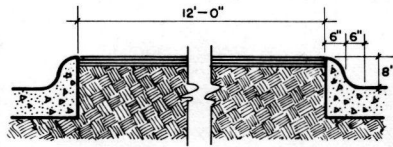

Figure 2. Mobile traffic analyzer (top). Interior of mobile traffic analyzer (bottom).

**A**

STUDY 04

DALLAS - CENTRAL EXPRESSWAY

**B**

STUDY 01

FORT WORTH - EAST WEST FREEWAY

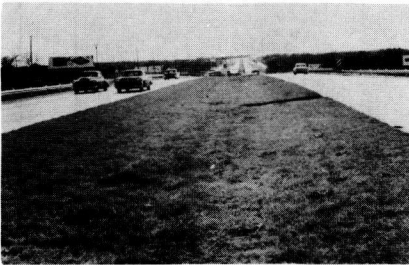
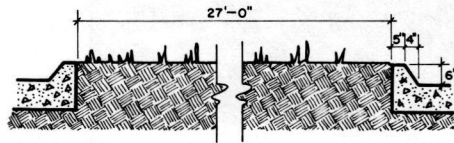
**C**

STUDY 03

DALLAS - CENTRAL EXPRESSWAY

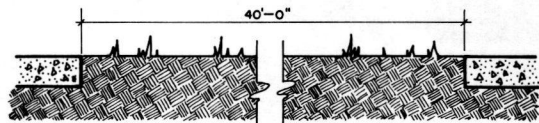
**D**

STUDY 05

DALLAS - U.S. 80

Figure 3. Median sections and typical study sites.



A

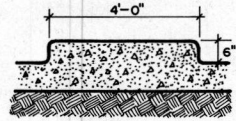

STUDY 00
HOUSTON - GULF FREEWAY



B

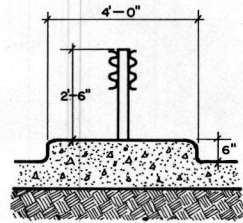

STUDY 07
HOUSTON - GULF FREEWAY

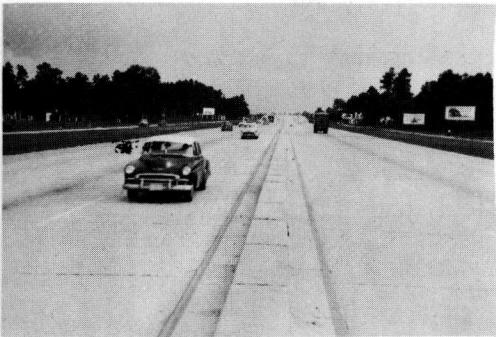

C

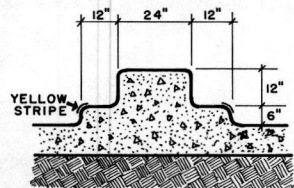

STUDY 08
HOUSTON - EASTEX FREEWAY

Figure 4. Median sections and typical study sites.

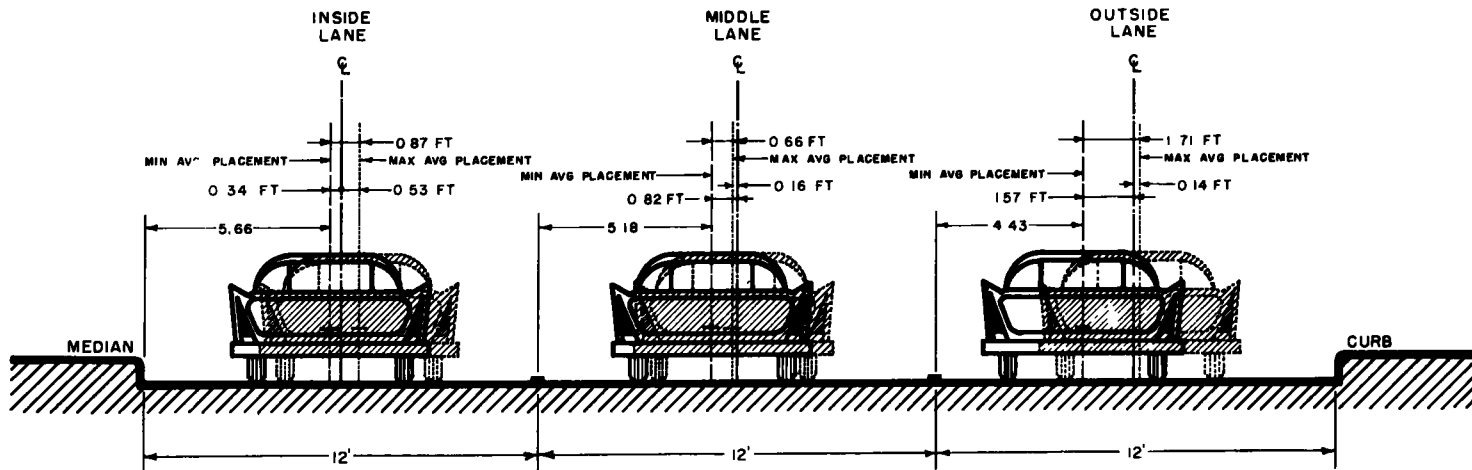

Figure 5. Variation in average placement—all daytime studies.

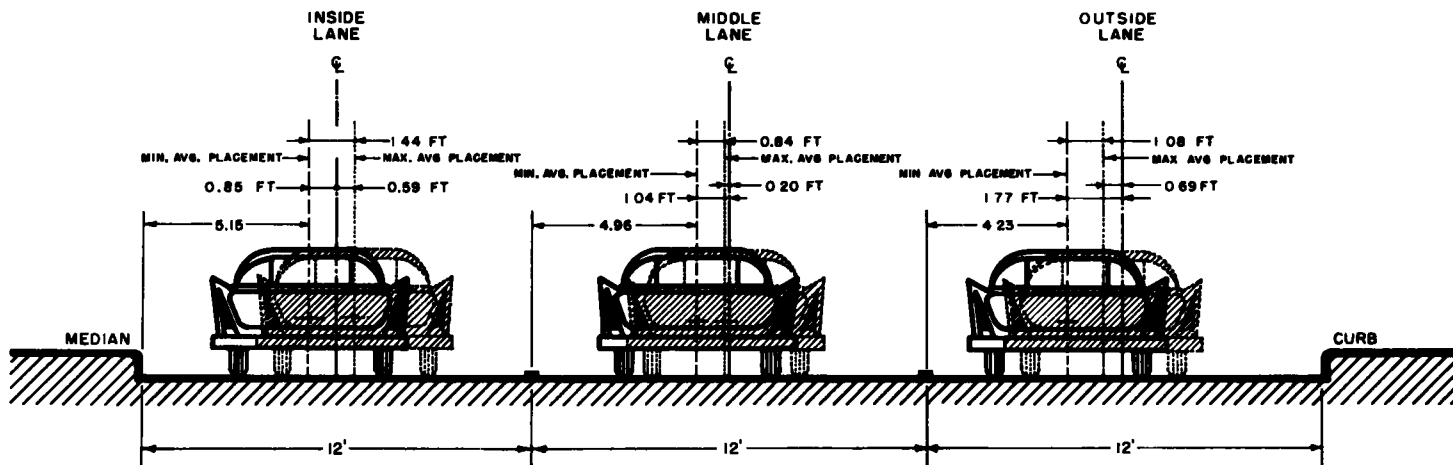

Figure 6. Variation in average placement—all night studies.

**TABLE I
AVERAGE VEHICLE PLACEMENTS
ALL B.P.R. STUDIES**

	DAY			NIGHT			STUDY NUMBER
	INSIDE LANE	MIDDLE LANE	OUTSIDE LANE	INSIDE LANE	MIDDLE LANE	OUTSIDE LANE	
AVG. PLACEMENT	5.86	5.18	4.87	5.85	4.96	4.23	STUDY 00 4' MEDIAN
NUMBER VEHICLES	5145	6323	3769	1163	2094	1196	
AVG. PLACEMENT	6.26	5.66	4.43	6.52	5.80	4.50	STUDY 01 12' MEDIAN
NUMBER VEHICLES	1924	2438	2576	94	688	120	
AVG. PLACEMENT	6.00	—	5.23	6.19	—	5.06	STUDY 03 27' MEDIAN
NUMBER VEHICLES	1287	—	1368	152	—	264	
AVG. PLACEMENT	5.66	5.38	5.10	5.15	5.35	4.83	STUDY 04 12' MEDIAN
NUMBER VEHICLES	4184	4859	1242	290	793	485	
AVG. PLACEMENT	6.19	—	6.14	6.59	—	5.31	STUDY 05 40' MEDIAN
NUMBER VEHICLES	433	—	1142	36	—	221	
AVG. PLACEMENT	6.53	5.84	5.38	6.23	5.51	5.05	STUDY 08 4' MEDIAN
NUMBER VEHICLES	676	616	528	98	661	103	
PLACEMENT MEASURED FROM LEFT LANE LINE							

TABLE 2
 AVERAGE SPEEDS, INSIDE LANES—DAYTIME
 B.P.R. SURVEYS

	Equivalent	Equivalent	
	Vol. Levels	Vol. Levels	
	0 - 600	600 - 1200	
Avg. Speed	48.8	48.8	
No. Vehicles	1017	2573	Study 00
Avg. Speed	54.4	49.5	
No. Vehicles	1761	202	Study 01
Avg. Speed	56.5	57.1	
No. Vehicles	1073	121	Study 03
Avg. Speed	48.7	47.7	
No. Vehicles	762	1132	Study 04
Avg. Speed	59.2	-----	
No. Vehicles	509	-----	Study 05
Avg. Speed	48.9	-----	
No. Vehicles	718	-----	Study 08

EFFECT OF BARRIER FENCE

During the median studies, a barrier fence (as shown in Fig. 7) was erected on the 4-ft median of the Gulf Freeway in Houston, Texas. Data taken before (study 00) and after (study 07) erection of this fence were analyzed to determine the effect of the barrier fence on traffic behavior and accidents.

Accident Study

The principal purpose of the barrier fence was to reduce the number of serious accidents resulting from vehicles crossing the median and colliding head-on with traffic in the opposing lanes.

In order to investigate accident experience on the freeway as related to the barrier fence, accident data were collected for periods of 2 yr before and 2 yr after the erection of the barrier fence.

The data were tabulated by total freeway accidents (accidents which occurred on the main freeway lanes and not including ramp and

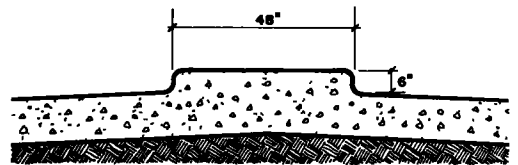

SECTION BEFORE CONSTRUCTION OF
 BARRIER FENCE

STUDY 00

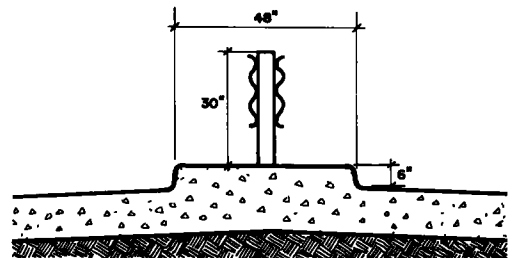

SECTION AFTER CONSTRUCTION OF
 BARRIER FENCE

STUDY 07

Figure 7. Median sections—Gulf Freeway, Houston.

frontage road accidents) and by median accidents (accidents which involved the median) (Table 3).

TABLE 3
ACCIDENT DATA, GULF FREEWAY, HOUSTON, TEXAS
1954 to 1958

Type of Accident	Property Damage	Personal Injury	Fatal	Total
Main-lane freeway (no./100 mil veh-mi):				
Before	166.98	26.33	2.63	195.94
After	206.58	24.34	2.01	232.93
Median (no.):				
Before	15	28	4	47
After	34	11	0	45
Median (no./100 mil veh-mi):				
Before				13.56
After				11.71

The data indicate that although the total accident rate per 100 million vehicle-miles increased (195.94 before to 232.93 after), the rate of the severe accidents decreased slightly (personal injury 26.33 before to 24.34 after and fatal 2.63 before to 2.01 after).

A study of the median accidents indicates that the median accident rate was only slightly reduced from 13.56 before to 11.71 after. The severity of the median accidents, however, appears to have been materially reduced. There were 4 fatal median accidents before compared with none after and 28 personal injury accidents involving the median before compared with 11 during the after period.

Statistical Analysis

Only the inside or median lane placements were studied in the analysis of the before and after data as these are the most critical with respect to the median and would likely reflect any effect on driver behavior that could be attributed to the median.

Two separate studies were analyzed: the Bureau of Public Roads' study taken at the location shown in Figure 8, and the film study conducted at the location shown in Figure 9. The motion picture study was conducted in the vicinity on an entrance ramp while the Bureau of Public Roads' study was conducted on a section with no ramps in the vicinity.

The variables considered in the study were before and after median conditions and traffic volume. Traffic volume was considered at three separate levels— V_1 (0-600 vph), V_2 (600-1200 vph), and V_3 (1200-1800 vph). The data were analyzed using an analysis of variance technique with the index F as a test statistic.

For both the Bureau of Public Roads and the motion picture studies, the following tests were made:

TABLE 4
ANALYSIS OF VARIANCE: BEFORE-AFTER STUDY OF BARRIER FENCE
B.P.R. SURVEYS

Source	df	Variance	F	df ₁	df ₂
Before (T ₁) and after (T ₂), without considering volume levels	1	0.2620	4.2532	1	94
Error	94	0.0616			
Total	95				
Volume levels V ₁ (0-600), V ₂ (600-1200) without considering before and after conditions	2	0.3198	5.4948 ^a	2	93
Error	93	0.0582			
Total	95				
Before and after considering only one level of traffic V ₁ (0-600)	1	0.0406	1.5675	1	29
Error	29	0.0259			
Total	30				
Before and after considering only one level of traffic V ₂ (600-1200)	1	1.0745	19.8613 ^b		
Error	52	0.0541			
Total	53				

^a Significance at 95% level of confidence.
^b Significance at 0.999 level of confidence.

TABLE 5
ANALYSIS OF VARIANCE: BEFORE-AFTER STUDY OF BARRIER FENCE
MOTION PICTURE SURVEYS

Source	df	Variance	F	df ₁	df ₂
Before and after without considering volume	1	0.1380	1.0144	79	1
Error	79	0.1400			
Total	80				
Volume levels V ₁ (0-6), V ₂ (6-12), and V ₃ (12-18) without considering before and after	2	1.4136	13.1742 ^a		
Error	78	0.1073			
Total	80				
After and before considering only one level of traffic V ₁ (0-600)	1	0.0994	2.1148	1	15
Error	15	0.0470			
Total	16				
After and before considering only one level of traffic V ₂ (600-1200)	1	0.0035	41.5428	33	1
Error	33	0.1454			
Total	34				
Before and after considering V ₃	1	0.1450	1.4963	1	27
Error	27	0.0969			
Total	28				

^a Significance at 0.999 level of confidence.

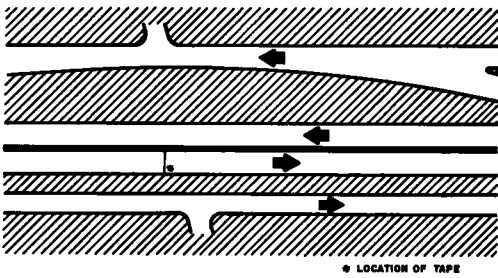

Figure 8. B.P.R. study site—Gulf Freeway, Houston, Texas.

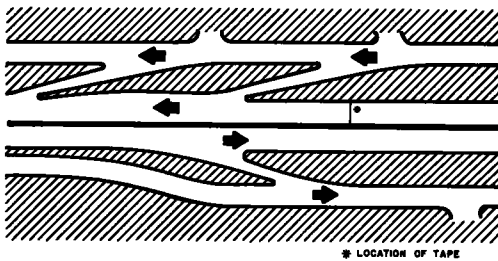

Figure 9. Motion picture study site—Gulf Freeway, Houston, Texas.

difference between before and after placements considering only the first level of traffic (0-600 vph).

4. There was a significant difference between before and after placements considering only the second level of traffic (600-1200 vph).

5. The data were not sufficient to compare before and after conditions at the third level of traffic (1200-1800 vph).

The following results were obtained from the analysis of the before and after motion picture studies:

1. There was no significant difference between the before and after placements when volume was not considered.

2. There was a significant difference between the placements grouped according to the three volume levels V_1 (0-600), V_2 (600-1200) and V_3 (1200-1800).

3. There was no significant difference between before and after placements at any of the three volume levels.

Conclusions

The results of the studies indicate the following conclusions:

1. The barrier fence was valuable in reducing the severity of accidents involving the median.

2. The barrier fence had no significant effect upon driver behavior as indicated by vehicle placement.

3. On the section where there were no ramps, a significant differ-

1. Test of significance comparing before and after placement data without considering volume levels.

2. Test of significance comparing the three volume levels without considering before and after conditions.

3. Test of significance comparing before and after placement data at each of the three volume levels.

Tabulations of the results from these studies are given in Tables 4 and 5.

The following results were obtained from the analysis of the Bureau of Public Roads' study.

1. There was no significant difference between the before and after placements when volume was not considered.

2. There was no significant difference between the placements grouped according to the three volume levels V_1 (0-600), V_2 (600-1200), and V_3 (1200-1800).

3. There was no significant difference between before and after placements considering only the first

ence between the before and after placements at the second level of traffic (600-1200 vph) indicated that the barrier fence had some effect on driver behavior as the volume increased.

4. The results of the analysis for the motion picture study indicated that volume had a more pronounced effect in this study than in the Bureau of Public Roads' study. This is probably a result of the entrance ramp conditions and the different time periods during which data were recorded. The motion picture study recorded data during three separate periods—7:00-8:30 A.M.; 9:30-10:30 A.M.; 4:00-5:30 P.M.—while the Bureau of Public Roads' study recorded data from 1:00 P.M. to 7:00 P.M. Thus the motion picture study reflected peak morning and afternoon conditions while the Bureau of Public Roads' study reflected only afternoon conditions.

The motion picture study indicated that volume conditions on both sides of the median affect vehicle placements. The average placements for the morning peak, offpeak and afternoon peak periods are shown in Figure 10 for the inside lane on the Gulf Freeway. A shift in vehicle placements toward the median during the morning peak and away from the median during the afternoon peak is indicated. The total change in average placement, comparing the morning peak (7:00-8:30 A.M.) with the afternoon peak (4:00-5:30 P.M.), is 0.58 ft. This effect is even more pronounced if peak 15-min periods (morning and evening) are compared for study 00 (before barrier fence) as shown in Figure 11. Here the total change is 0.89 ft. This difference was slightly less (0.67 ft) after the barrier fence was erected as shown in Figure 12. Thus it is evident that the opposing flow has a large amount of effect on vehicle placements in this study of a narrow median.

GENERAL MEDIAN STUDY

In order to develop knowledge of the effect of various type and width freeway medians on traffic behavior, a specific study was conducted using placement data recorded on freeways with the following median types:

Study	Location	Median Type
00	Houston - Gulf Freeway	4-ft Concrete with barrier curb
03	Dallas - Central Expressway	12-ft Concrete with barrier curb
04	Dallas - Central Expressway	27-ft Grassed with barrier curb
05	Dallas - US 80	40-ft Grassed, no curb

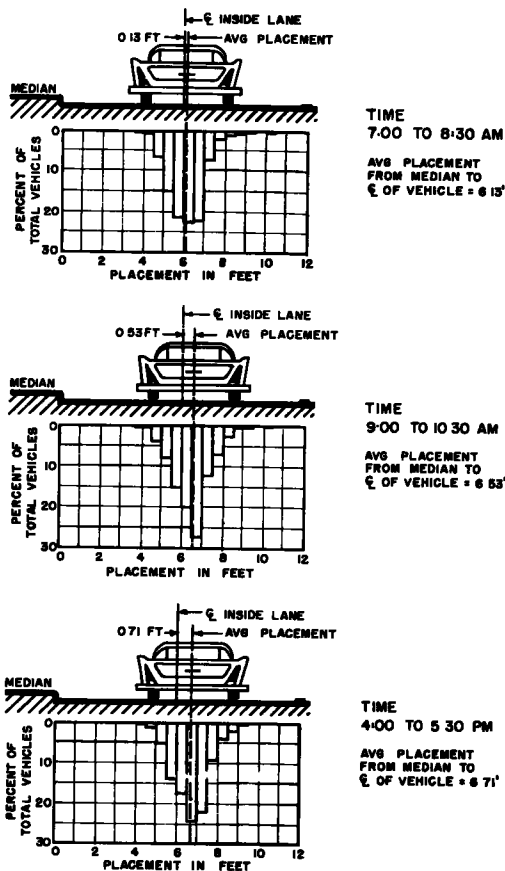
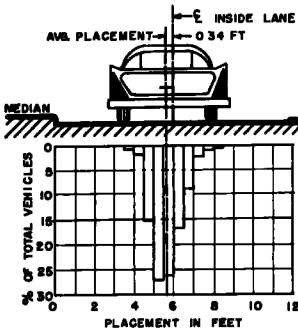
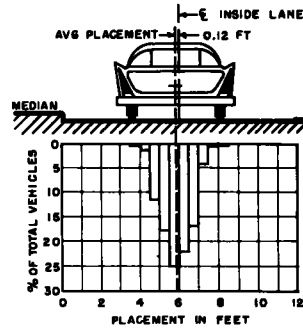

Figure 10. Average placements in median lane—Gulf Freeway.



MORNING PEAK
7:15 TO 7:30 AM
AVG. PLACEMENT
FROM MEDIAN TO
 ξ OF VEHICLE = 5.66'
VARIANCE = 0.818



MORNING PEAK
7:25 TO 7:40 AM
AVG. PLACEMENT
FROM MEDIAN TO
 ξ OF VEHICLE = 5.88'
VARIANCE = 0.813

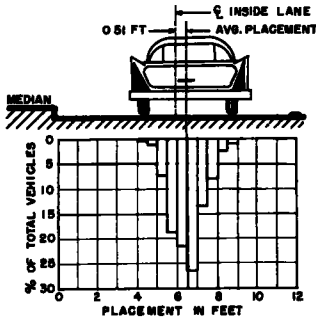

AFTERNOON PEAK
4:31 TO 4:46 PM
AVG. PLACEMENT
FROM MEDIAN TO
 ξ OF VEHICLE = 6.51'
VARIANCE = 0.819

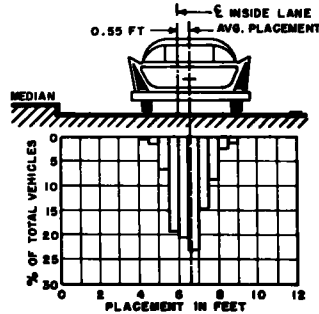

AFTERNOON PEAK
4:31 TO 4:46 PM
AVG. PLACEMENT
FROM MEDIAN TO
 ξ OF VEHICLE = 6.56'
VARIANCE = 0.700

Figure 11. Average placements in median lane before barrier fence—Gulf Freeway.

Figure 12. Average placements in median lane after barrier fence—Gulf Freeway.

Statistical Analysis

In order to study the relationship of various type medians a number of comparisons of placement data were made. Because the difference in the average placements was small for the various type medians, the variance of the data was studied to determine any significant differences that occurred.

The data were grouped according to volume levels V_1 (0-600 vph), V_2 (600-1200 vph) and V_3 (1200-1800 vph) and by day-night periods. The tests that were made and the results of these tests are given in Table 6.

Comparisons of vehicle placements were made for the following medians:

1. Comparison of all medians;
2. Comparison of 4-ft median with 12-ft median;
3. Comparison of 4-ft median with 27-ft median;
4. Comparison of 4-ft median with 40-ft median;
5. Comparison of 12-ft median with 27-ft median; and
6. Comparison of 27-ft median with 40-ft median.

In order to obtain the various size median sections for study, it was necessary to study a number of freeway sections. This placed some limitations on the comparisons that could be made because it was impossible to obtain a full range of volume conditions on all of the sections. For example, only one level of traffic (0-600) could be compared for night and day. For this reason some comparisons were impossible.

**TABLE 6
GENERAL MEDIAN STUDY
TEST RESULTS**

S	V	1	2	3	4	5	6
		V ₁ V ₂ V ₃ T ₁ T ₂	V ₁ T ₁ T ₂	V ₁ V ₂ V ₃ T ₁	V ₁ T ₁	V ₂ T ₁	V ₃ T ₁
STUDY-00 & STUDY-08	S	+++	+++	+++	+++	+++	++
	V	+++		+++			
	T	NO SIGNIFICANCE	+				
STUDY-00 & STUDY-03	S ₁	+++	+++	NO SIGNIFICANCE	NO SIGNIFICANCE	NO SIGNIFICANCE	NO DATA S-03
	V	NO SIGNIFICANCE		++			
	T	NO SIGNIFICANCE	NO SIGNIFICANCE				
STUDY-00 & STUDY-04	S ₂	NO SIGNIFICANCE	+++	NO SIGNIFICANCE	++	NO SIGNIFICANCE	++
	V	+++		+++			
	T	NO SIGNIFICANCE	+++				
STUDY-00 & STUDY-05	S ₃	++	++	NO SIGNIFICANCE	NO SIGNIFICANCE	NO DATA S-05	NO DATA S-05
	V	NO SIGNIFICANCE		NO SIGNIFICANCE			
	T	NO SIGNIFICANCE	NO SIGNIFICANCE				
STUDY-00 & STUDY-07	S ₄	NO SIGNIFICANCE	NO DATA S-07		NO SIGNIFICANCE		NO DATA S-07
	V	+		NO DATA S-07			
	T	NO DATA S-07	NO DATA S-07				
STUDY-03 & STUDY-04	S ₅	++	NO SIGNIFICANCE	+	NO SIGNIFICANCE	NO SIGNIFICANCE	NO DATA S-03
	V	+++		+++			
	T	+	NO SIGNIFICANCE				
STUDY-03 & STUDY-08	S ₆	+++	NO SIGNIFICANCE	NO SIGNIFICANCE	NO SIGNIFICANCE	NO DATA S-05	NO DATA S-03 & 06
	V	NO SIGNIFICANCE		NO SIGNIFICANCE			
	T	+++	NO SIGNIFICANCE				
STUDY-04 & STUDY-05	S ₇	NO SIGNIFICANCE	NO SIGNIFICANCE	NO SIGNIFICANCE	NO SIGNIFICANCE	NO DATA S-05	NO DATA S-05
	V	+		++			
	T	NO SIGNIFICANCE	NO SIGNIFICANCE				

S - STUDY 00, 03, 04 05, 06, 07, 08) S₁-STUDY 00, 07
 S₂- STUDY 03, 03 S₂-STUDY 03, 04
 S₃- STUDY 00, 04 S₃-STUDY 03 05
 S₄- STUDY 00, 06 S₄-STUDY 04, 05

V - VOLUME OF TRAFFIC
 V₁ - 0-800VPM
 V₂ - 800-1200
 V₃ - 1200-1800

T - PERIOD
 T₁ - DAY
 T₂ - NIGHT

+- SIGNIFICANT AT 95% LEVEL OF CONFIDENCE

++- SIGNIFICANT AT 99% LEVEL OF CONFIDENCE

+++- SIGNIFICANT AT 999% LEVEL OF CONFIDENCE

COLUMN

1 { TEST OF SIGNIFICANCE FOR THE VARIATION IN EACH VARIABLE (STUDY, VOLUME PERIOD) WITHOUT CONSIDERING THE INFLUENCE OF THE OTHER VARIABLES

2 { TEST OF SIGNIFICANCE FOR THE VARIATION IN STUDY OR PERIOD CONSIDERING ONLY ONE VOLUME LEVEL (V₁) AND WITHOUT CONSIDERING THE INFLUENCE OF THE OTHER VARIABLE

3 { TEST OF THE SIGNIFICANCE FOR THE VARIATION IN STUDY AND VOLUME CONSIDERING ONLY DAYTIME DATA AND WITHOUT CONSIDERING THE INFLUENCE OF THE OTHER VARIABLE

4, 5, 6 { TEST OF SIGNIFICANCE FOR THE VARIATION IN STUDY CONSIDERING ONLY DAYTIME DATA AND SEPARATE LEVELS OF VOLUME (V₁, V₂)

The results of the comparisons were as follows:

General Results - Including all studies:

1. There was a significant difference in placements among the studies.
2. There was a significant difference in placements grouped according to the three volume levels for all studies.
3. There was no significant difference between day and night placements at the first level of traffic (0-600 vph).
4. There was a significant difference in placements at each volume level for all studies.

Study 00 with 04 - 4-ft with 12-ft:

1. There was no significant difference in placements between the studies without considering volume.
2. There was a significant difference in placements grouped according to the three volume levels for both studies.
3. There was no significant difference between day and night placements at the first level of traffic (0-600 vph).
4. There was a significant difference in placements at each volume level for these studies.

Study 00 with 03 - 4-ft with 27-ft:

1. There was a significant difference in placements between the studies without considering volume.
2. There was no significant difference in placements grouped according to the three volume levels for both studies.
3. There was no significant difference between day and night placements at the first level of traffic (0-600 vph).
4. There was no significant difference in placements at each volume level for these studies.

Study 00 with 05 - 4-ft with 40-ft:

1. There was a significant difference in placements between the studies without considering volume.
2. There was no significant difference in placements grouped according to the three volume levels for both studies.
3. There was no significant difference between day and night placements at the first level of traffic (0-600).
4. There was not sufficient data to compare all volume levels for these studies.

Study 04 with 03 - 12-ft with 27-ft:

1. There was a significant difference in placement between the studies without considering volume.
2. There was a significant difference in placements grouped according to the three volume levels for both studies.
3. There was no significant difference between day and night placements at the first level of traffic (0-600 vph).
4. There was not sufficient data to compare all volume levels for these studies.

Study 03 with 05 - 27-ft with 40-ft:

1. There was a significant difference in placements between the studies without considering volume.

2. There was no significant difference in placements grouped according to the three volume levels for both studies.
3. There was no significant difference between day and night placements at the first level of traffic (0-600 vph).
4. There was not sufficient data to compare all volume levels for these studies.

Conclusions

The following conclusions were drawn from the results of the various comparisons made in the general study:

1. Although the change in average placements was relatively small for all studies, a study of the variation in the data indicates that median width does significantly affect traffic behavior.

2. The following comparisons were made:

- a. 4-ft median with 12-ft median;
- b. 4-ft median with 27-ft median;
- c. 4-ft median with 40-ft median; and
- d. 12-ft median with 27-ft median.

The results of the tests indicate no significant difference in placements for comparison (a) but a significant difference in placements for comparisons (b), (c), and (d). Thus the wide medians (27 ft and 40 ft) compared with the narrow medians (4 ft and 12 ft) reflect a significant change in traffic behavior that is not apparent when comparing the narrow medians with each other. This indicates, though all variations in average placement are slight, the narrow medians have a different effect on driver behavior from the wider medians.

3. A study of vehicle placements with regard to volume was made for the following comparisons:

- a. 4-ft with 12-ft;
- b. 12-ft with 27-ft;
- c. 4-ft with 27-ft; and
- d. 4-ft with 40-ft.

The results of these tests indicate that volume had a significant effect on placements for comparisons (a) and (b) but no significant effect for comparisons (c) and (d). This indicates a reduction in the effect of volume on vehicle placement for the wider medians (27 ft, 40 ft) as compared to the narrow medians (4 ft, 12 ft). Thus, the wider medians appear desirable to reduce or eliminate the effect of heavy volumes on the driver's behavior.

SUMMARY

The data analyzed indicated that variations in vehicle placements on freeways are relatively small. Data on vehicle placements and observations of over-all freeway operation indicate that median widths as small as 4 ft are satisfactory. However, numerous median accidents were observed and the accident data indicated that a barrier fence on the 4-ft median was very effective in reducing the severity of median accidents. Also, the results of placement data analyses indicated that the barrier fence had no significant effect on driver behavior.

In the general median studies which compared various width medians, it was found that median widths did affect traffic behavior as indicated by vehicle placements. A difference in driver behavior was noted when comparing wide medians with narrow medians and the data indicated that

wide medians are valuable in reducing or eliminating the effect of opposing flow and heavy volumes on traffic behavior.

Comparisons of day and night placement data in the volume range of 0-600 vph indicate no significant difference between day and night vehicle placement.

ACKNOWLEDGMENT

This research project was conducted by the Texas Transportation Institute for and in cooperation with the Texas Highway Department. Grateful acknowledgment is made to representatives of the Texas Highway Department and the Cities of Houston, Dallas, and Fort Worth, who served on the Project Advisory Committee, for their valuable advice and assistance.

Gratitude is also expressed to the Bureau of Public Roads for their participation in these studies.