

Laboratory Study of Spur Dikes for Highway Bridge Protection

SUSUMU KARAKI, Assistant Research Engineer, Civil Engineering Department, Colorado State University, Fort Collins, Colorado

This research study of spur dikes was sponsored by the State Highway Departments of Mississippi and Alabama in cooperation with the Bureau of Public Roads, Washington, D. C. It was conducted for the purpose of determining the value of spur dikes as protection for bridge abutments and to determine the relationships between the various geometric parameters.

The investigation was made in two stages; first, the effectiveness of the spur dike for reducing scour was demonstrated, the location and shape determined, and second, criteria were established for determining the length of dike required at a particular location. The results are qualitative and restricted by the limitations of the study.

● PROTECTION of bridge abutments and piers from scour during floods has long posed a problem to bridge engineers. Bridge failures by scour could be prevented if bridges were constructed to span the entire channel with no obstruction in the channel. This method, of course, would be impractical and expensive. Bridges could also be protected if the foundations extended to sufficient depths to avoid undermining by scour. Although this is perhaps a better solution in most instances, knowledge of scour phenomenon has not yet advanced to a stage where reliable predictions of scour depths can be made.

Scour at bridge abutments is caused primarily by flow concentrations and turbulence. It has been found that flow concentrations at the abutment can be reduced by streamlining the approach to the bridge opening with spur dikes located at the abutments. Spur dikes are guides to direct the flow properly through the bridge while distributing the flow across the opening and making the entire passage a more efficient waterway.

Spur dikes have been used in a number of states. Some, as in Georgia have been constructed of timber; others, as in Pennsylvania, have been constructed with rock-fill embankments. In Missouri, Mississippi and Alabama, they have been constructed with earth fill embankments. In all cases, the chief purpose of the spur dikes is to protect the bridge foundations from scour by reducing high local velocities and preventing excessive turbulence and eddy formation.

Despite the numerous and varied types of construction of spur dikes, there is still an apparent lack of adequate criteria to be used as guides to proper design. It is perhaps for this reason that spur dikes are not more frequently used, for certainly the cost of spur dikes in most cases is small compared to the total cost of the bridge or the entire highway project. To establish criteria for design of spur dikes, the sponsors arranged for a research study to be conducted at the Hydraulics Laboratory of Colorado State University. The study was conducted in two stages: The first stage was to determine the effectiveness of spur dikes and the important variables to be considered in a detailed study. The second stage was to establish criteria, however tentative, as a

guide to design. The entire study was primarily qualitative in nature; that is, the models show where scour will probably occur but cannot be scaled to indicate how deep the scour might go for prototype conditions.

Recognizing that wide stream channels consist of two parts, a main channel and flood plains for overbank flow, this research was limited to study of spur dikes for abutments on the flood plain away from the main channel. This paper is a report on these model studies, and the results can be used as a guide for design where distribution of flow on the flood plain is reasonably uniform.

LABORATORY EQUIPMENT

Flume

The laboratory study was conducted in a flume 16 ft wide and 84 ft long (Fig. 1). It consisted of two sections of flume, each 32 ft long, separated by a recessed section 4 ft deep and 20 ft long for the purpose of providing scour depth at the test section. The bed of the flume consisted of sand to form an erodible bed with a fixed slope of 0.0003. Water was supplied to the flume by a 14-in. pump and recirculated. Discharge measurements were made with a flat plate orifice and a standard differential air-water manometer.

As the study progressed it became desirable to establish concentrated flow along the roadway embankment. This was accomplished by constructing a separate inflow to the flume at one side of the test section. Water was supplied to the side box by an 8-in. pump connected to the same recirculating system.

Models

Highway embankment models were made 1 ft wide at the top and the roadway was placed 0.6 ft above the flume bed. The embankment side slopes were $1\frac{1}{2}:1$. The spur dikes were of both erodible and non-erodible types. For the initial and latter part of the study involving riprap, erodible dikes were used. All dikes were 3 in. wide at the top and constructed to the same height as the roadway embankment. Side slopes of the dikes were $1\frac{1}{2}:1$ except for the riprap studies where 2:1 slopes were studied to observe effects of undercutting. Riprap for the dikes consisted of $\frac{3}{8}$ -in. median size gravel

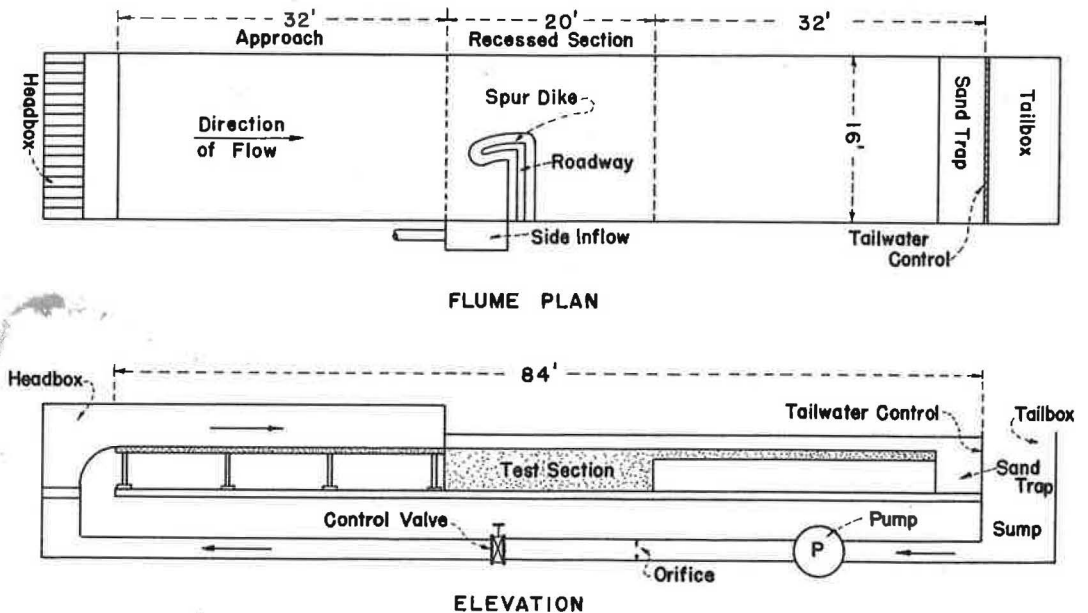

Figure 1. Schematic drawing of test equipment.

with gradation in size from $\frac{1}{4}$ in. to $\frac{1}{2}$ in. The gravel was placed at random on the face of the dike.

TEST PROCEDURES

The procedure used for all runs was the same after certain pilot runs were made. The entire study was limited to clear water (no upstream or recirculating supply of sediment) with flow quantities varying with the size of the flume constriction. Pilot runs were first made to determine the flow discharge in the flume which, at about 0.4-ft depth, would not develop ripples or dunes on the sand bed but the shear force on the bed would be near the critical tractive force of the bed material. This test was made with no roadway constriction in the flume. The desirable discharge was found to be 4.8 cfs which gave an average velocity in the flume of 0.75 ft per sec. Measurement of velocity in the flume was made with a Pitot tube and adjustments were made in the head box so that a uniform distribution of flow was obtained across the width of the flume.

The length of roadway embankment necessary to develop measurable scour depth was determined by trial. At a contraction of 0.5, scour depth reached a value of 0.75 ft in a period of 5 hr and increased very little after that time. Since sediment was not supplied in the flow, equilibrium scour conditions could not be expected within a relatively short period of time. Therefore, it was decided to standardize test time rather than to proceed to equilibrium conditions because the study was primarily qualitative and it was desired to avoid an unnecessary amount of time for each run. Flow depth of 0.4 ft was used in all tests measured at a section 4 ft upstream from the tailgate control.

In tests involving flow from the side, the total discharge with a given bridge opening was held constant for comparative purposes and to avoid transport of sand in the flume. Thus, the discharge from the head box was reduced by the amount of the side inflow. By this procedure, a longer roadway embankment was simulated by assuming that the side flow essentially represented an additional width of the flume. The additional length of embankment was computed by dividing the total side discharge by the unit discharge from the headbox.

Procedure for Each Test

The channel bed was leveled before each run and the same bed slope was used for all tests. Water was introduced into the flume from both the upstream and downstream ends to prevent scour at the test section before proper flow conditions were established in the flume. After filling the flume to the proper depth, the downstream pump was shut off and the upstream discharge increased to the proper amount. The water depth was controlled by the tailgate to 0.4-ft depth at the downstream end of the flume. After 5 hours' run, the upstream discharge was shut off and as the water receded in the test section, the scour hole which formed at the bridge and spur dikes was contoured at 0.1-ft intervals. The water surface in the scour hole was measured with a point gage.

Data Taken

The results of all tests were recorded by photographs in both motion pictures and still photographs, and most of the measured data were obtained directly from the photographs.

RESULTS

Notation

The following is a list of definitions for symbols used in this paper. Terms are also defined in Figure 2 and where they first appear in the text.

L_o = Length of bridge opening in the flume (ft).

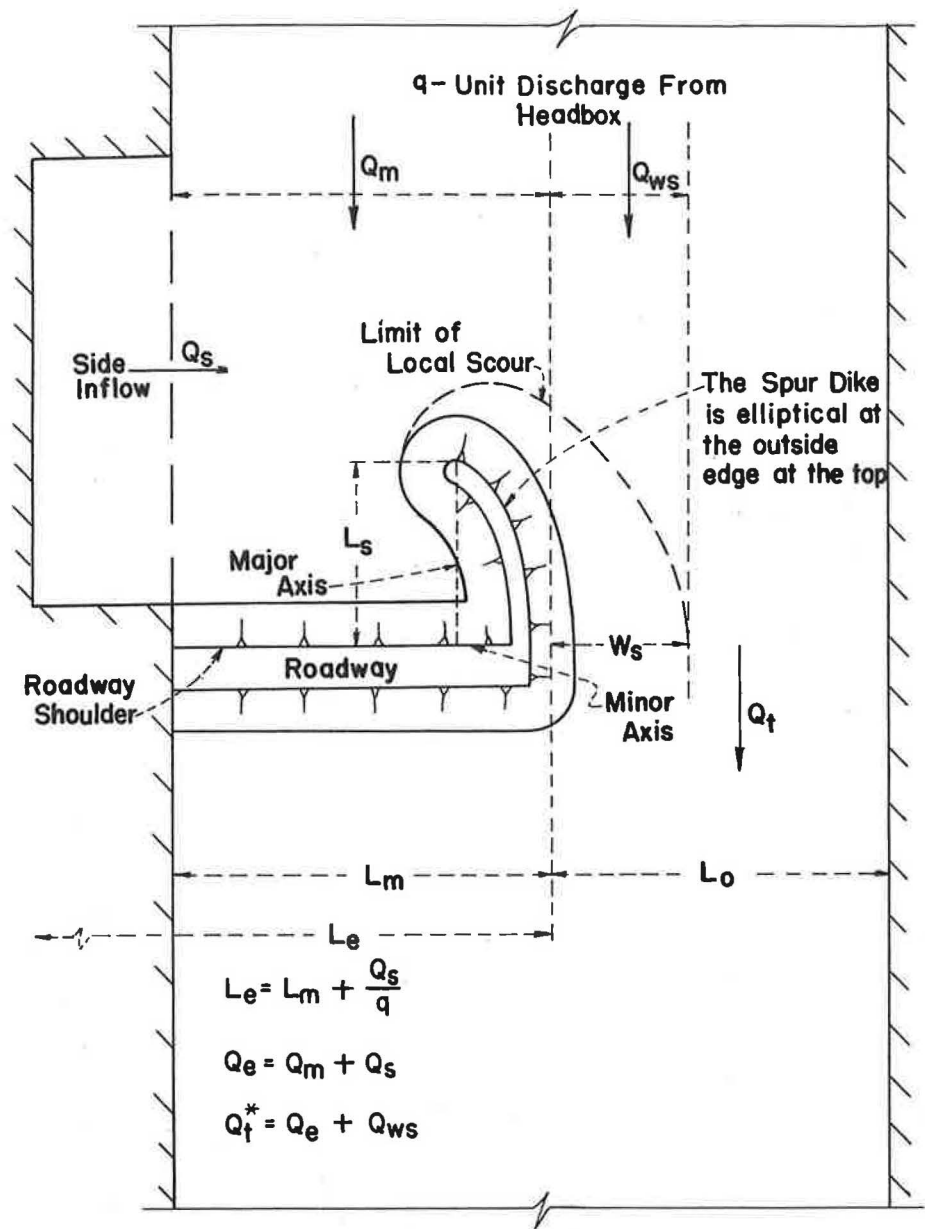

Figure 2. Definition sketch for symbols.

- L_s = Length of spur dike measured along the major axis of the ellipse, normal to the roadway (ft).
 L_e = Equivalent length of roadway embankment projecting into the stream channel normal to the direction of flow (ft).
 λ = Ratio of the major axis to the minor axis of the elliptical spur dike.
 W_s = The width at the bridge section, measured from the abutment, through which the embankment flow Q_e is concentrated (ft).
 d_s = Depth of scour measured at the bridge section (ft).
 Q_m = Quantity of flow in the flume obstructed by the roadway (cfs).

- Q_t = Total discharge through L_o of the flume (cfs).
 Q_t^* = Total discharge through the length W_s , equal to $Q_s + Q_m + Q_{ws}$ (cfs).
 Q_{ws} = Quantity of flow approaching W_s normally (cfs).
 Q_s = Quantity of flow entering from the side of the flume (cfs).
 Q_e = Quantity of flow obstructed by the embankment equal to $Q_s + Q_m$ (cfs).
 q = Unit discharge per width of flume from head box.
 m = Contraction ratio of the flume equal to $\frac{16 - L_o}{16} = \frac{L_m}{16}$.

Effect of Spur Dike Shape and Location

The initial stage of the study was conducted to demonstrate the effectiveness of spur dikes to control scour at the bridge foundation and to develop a better understanding of the important variables involved. The results of the study are assumed to be comparative, except for those otherwise designated.

Figure 3 shows scour that can occur at a bridge abutment which in most instances would probably cause undermining of the abutment with possible failure of the first few spans of the bridge. Contour interval of the scour hole is 0.1 ft. The scour hole is caused by large velocities due to flow concentration, which develop shear forces greater than the bed material can withstand. This is augmented by the development of turbulence due to merging flow near the abutment. The effectiveness of a spur dike to reduce scour at the bridge is shown in Figure 4. Although there is evidence of scour at the end of the dike, actual scour at the bridge section is reduced, demonstrating that the bridge of Figure 3 would probably have failed, but the bridge of Figure 4 would not have been threatened severely for the same flood condition.

The importance of spur dike location is shown in Figures 5 and 6. As the dike is offset from the abutment, there is increasing scour at the bridge section, and when the dike becomes sufficiently displaced from the abutment two distinct scour holes form, one at the abutment and another at the tip of the dike. It was demonstrated by these tests that the spur dike should be located at the abutment to be most effective.

When a channel is constricted by a roadway, the obstructed flow is forced to flow around the constriction. Under this condition, the flow lines are usually curved near the bridge abutments. Because of this natural curvature, it would seem logical for a curved dike to develop better streamlining than a straight dike. There are a multiplicity of curved shapes that could be used: parabolic, hyperbolic, spiral, elliptical, and circular. Of these, the elliptical is probably the simplest geometrical shape and the one to be considered because of the adaptability to field layout. A convenient reference is established by locating the minor axis of the ellipse along the roadway shoulder and arranging the side slope of the spur dike so that it becomes tangent to the abutment (in the case of spill-through abutments).

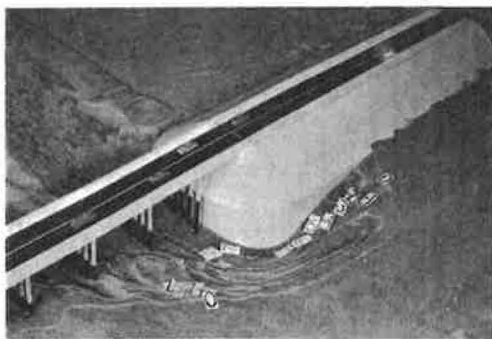

Figure 3. Scour at a spill-through abutment. $L_s = 0$ $Q_t = 4.8$ cfs $Q_s = 0$ $L_o = 8.0$ ft.



Figure 4. Scour at the bridge is reduced although there is scour at the end of the spur dike. $\lambda = 2\frac{1}{2}$ $L_s = 3.0$ ft $Q_t = 4.8$ cfs $Q_s = 0$ $L_o = 8.0$ ft.

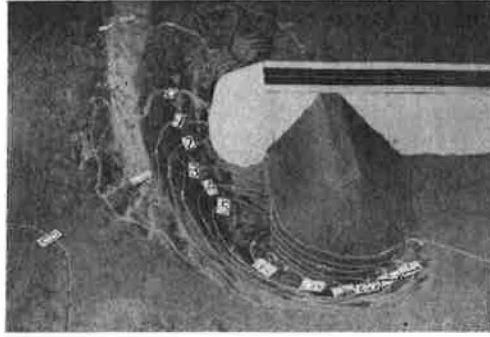

Figure 5. Straight spur dike is offset from the abutment a distance of $0.4 L_S$.
 $L_S = 2.28$ ft $Q_t = 4.8$ cfs $Q_S = 0$ $L_O = 8.0$ ft.

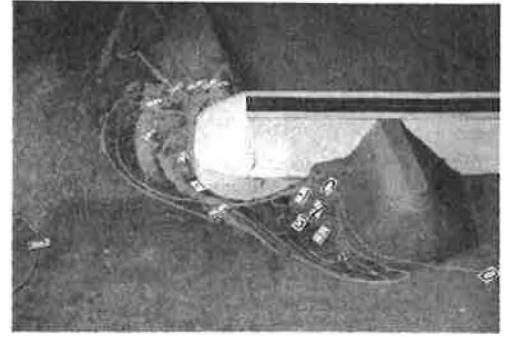

Figure 6. Straight dike is offset from the abutment a distance of L_S . $L_S = 2.28$ ft $Q_t = 4.8$ cfs $Q_S = 0$ $L_O = 8.0$ ft.

Figure 7 shows the results of tests conducted for two spur dike lengths of various elliptical shapes with the major axis normal to the roadway and the minor axis along the roadway shoulder line. As the shape of the dike becomes more nearly circular, there is an increase of d_S , the scour depth at the bridge. This is reasonable, for as the dike assumes a greater degree of curvature, the concentration of flow is greater along the dike. The results also show that another important variable in designing spur dikes is the length, L_S , along the major axis. For the two lengths, 2.27 ft and 3.41 ft, tested d_S decreases with an increase in L_S .

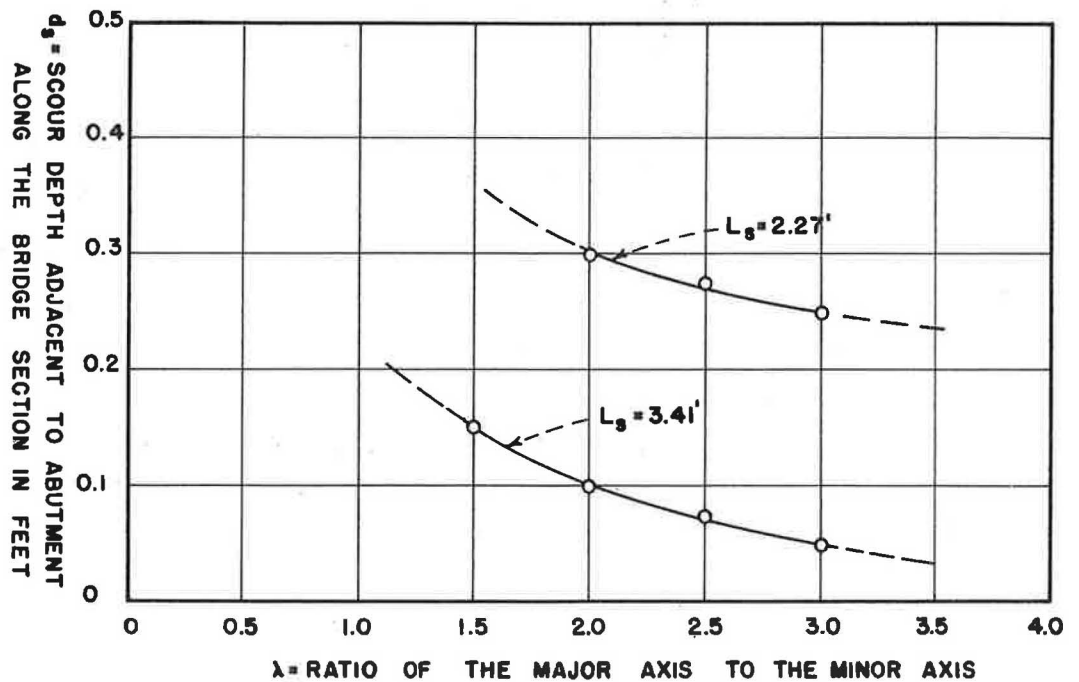

Figure 7. Relationship between the curvature of the ellipse and scour at the bridge section.

Observations made during these tests indicated that although the 3:1 elliptical dike appears to be best from the standpoint of least scour, the flow did not follow the boundary of the dike. As a consequence, the total bridge opening was not fully effective. This is indicated by deposition of sand adjacent to the abutment (Fig. 8). Figure 9 shows the test results with a $2\frac{1}{2}$:1 elliptical dike of the same length showing no deposition. The latter indicates better utilization of the bridge opening. The more efficient bridge opening with $\lambda = 2\frac{1}{2}$ offsets the slightly greater depth of scour, therefore, the $2\frac{1}{2}$:1 elliptical dike was selected as standard in the remainder of the tests.

Effect of Spur Dike Length

The preliminary study has demonstrated the effectiveness of spur dikes to protect bridge abutments from scour. In designing a spur dike it is necessary to consider its principal functions. These are (a) to distribute the concentrated flow at the abutment as uniformly as possible through the bridge opening, and (b) to reduce the mean velocity adjacent to the abutment and decrease the turbulence. The dikes can be made to perform these functions by choosing proper shape, location and length. The dike at the abutment was shown to be the desirable location and an elliptical spur dike with a $2\frac{1}{2}$:1 major-to-minor axis ratio to be most effective. The length requirement of the dike remained to be established.

Results of tests made with normal embankments, and $\lambda = 2\frac{1}{2}$ are given in Table 1. These tests were made to determine the effect of embankment length, L_e , and discharge on the spur dike length. Although values of L_e varied, there were basically three sizes of clear bridge openings, L_o , tested in the flume. Values of L_o were 4.8, 8, and 11.2 ft. The various parameters are shown in Figure 2. In these tests, it was assumed that the wall of the flume in the bridge opening approximated a flow line and that the wall had little or no influence on the scour pattern around the dikes and the abutment. This was not found to be true for all of the tests with the small opening of 4.8 ft. The larger openings of 11.2 ft were not included in the results, because they required such large discharges (in order to be comparable to the other tests) that general movement of the bed was developed in the flume.

For each value of L_o , data from spur dike lengths of 1.5, 2, 3, and (where possible) 4 ft were obtained. To simulate longer roadway embankments, a side discharge, Q_s , varying to a maximum of 1.5 cfs was used. The discharge was converted to equivalent additional flume width using the assumption of uniform approach flow. Because L_o remained constant, the additional flume width meant increased embankment length.

The results plotted dimensionally (Fig. 10) show the influence of spur dike length on

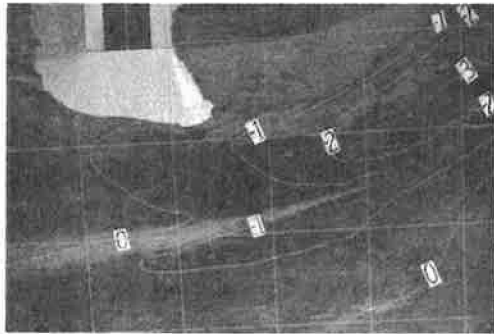

Figure 8. Note the 0 contour is midway along the embankment. There is deposition downstream from this point. $\lambda = 3$ $L_s = 3.41$ ft $Q_t = 4.80$ cfs $Q_s = 0$ $L_o = 8.0$ ft.

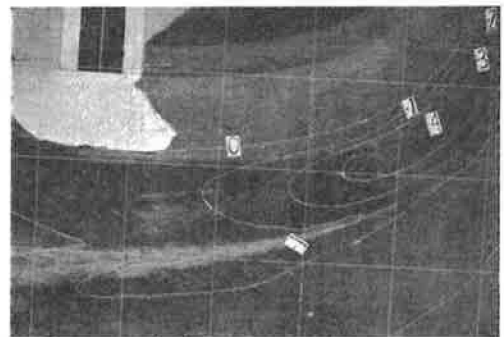

Figure 9. No deposition along abutment. $\lambda = 2\frac{1}{2}$ $L_s = 3.41$ ft $Q_t = 4.80$ cfs $Q_s = 0$ $L_o = 8.0$ ft.

TABLE 1
MEASURED AND CALCULATED DATA FOR NORMAL EMBANKMENTS

| Q_s | Q_t | $Q_t - Q_s$ | $q = \frac{Q_t - Q_s}{16}$ | $m = \frac{L_s}{16}$ | $m(Q_t - Q_s) = \frac{Q_t - Q_s}{L_s}$ | $Q_m = Q_s + Q_t$ | W_s | $\frac{Q_s}{m W_s} = \frac{Q_s}{Q_s + Q_t}$ | $Q_t = Q_s + W_s$ | $\frac{Q_t}{Q_s} = \frac{Q_t}{Q_s + W_s}$ | $L_e = \frac{Q_s}{q}$ | L_s | $\frac{L_s}{L_e}$ | d_s | $\frac{d_s}{L_s}$ | $\frac{W_s}{L_e}$ |
|--------|-------|-------------|----------------------------|----------------------|--|-------------------|-------|---|-------------------|---|-----------------------|-------|-------------------|-------|-------------------|-------------------|
| 0 | 3.0 | 3.0 | .188 | 0.7 | 2.10 | 2.10 | 3 | 0.56 | 2.66 | .790 | 11.2 | 0 | 0 | 0.55 | -- | .268 |
| 0 | 3.0 | 3.0 | .188 | 0.7 | 2.10 | 2.10 | 4 | 0.75 | 2.85 | .736 | 11.2 | 1.5 | .134 | 0.30 | .200 | .357 |
| .75 | 3.0 | 2.25 | .141 | 0.7 | 1.58 | 2.33 | 4 | 0.56 | 2.89 | .806 | 16.55 | 1.5 | .091 | 0.33 | .220 | .242 |
| 1.50 | 3.0 | 1.50 | .094 | 0.7 | 1.05 | 2.55 | 4 | 0.38 | 2.93 | .870 | 27.2 | 1.5 | .055 | * | -- | .147 |
| 0 | 3.0 | 3.0 | .188 | 0.7 | 2.10 | 2.10 | 4.5 | 0.85 | 2.95 | .712 | 11.2 | 2.0 | .178 | 0.30 | .150 | .401 |
| 0.5 | 3.0 | 2.5 | .156 | 0.7 | 1.75 | 2.25 | 4.5 | 0.70 | 2.95 | .763 | 14.4 | 2.0 | .139 | 0.15 | .075 | .312 |
| 1.5 | 3.0 | 1.50 | .094 | 0.7 | 1.05 | 2.55 | 4.5 | 0.42 | 2.97 | .859 | 27.2 | 2.0 | .074 | 0.35 | .175 | .165 |
| 0 | 3.0 | 3.0 | .188 | 0.7 | 2.10 | 2.10 | 4.6 | 0.86 | 2.96 | .709 | 11.2 | 3.0 | .268 | 0.20 | .067 | .410 |
| 0.4 | 3.0 | 2.6 | .163 | 0.7 | 1.82 | 2.22 | 4.6 | 0.75 | 2.97 | .747 | 13.68 | 3.0 | .219 | 0.22 | .073 | .345 |
| 0.75 | 3.0 | 2.25 | .141 | 0.7 | 1.58 | 2.33 | 4.6 | 0.65 | 2.98 | .782 | 16.55 | 3.0 | .181 | 0.25 | .083 | .285 |
| 0 | 4.80 | 4.80 | .300 | 0.5 | 2.400 | 2.40 | 3.0 | 0.90 | 3.30 | .727 | 8.0 | 0 | 0 | 0.65 | -- | .375 |
| 0.25 | 4.80 | 4.55 | .284 | 0.5 | 2.28 | 2.53 | 3.0 | 0.85 | 3.38 | .749 | 8.90 | 0 | 0 | 0.65 | -- | .337 |
| 0.75 | 4.80 | 4.05 | .253 | 0.5 | 2.03 | 2.78 | 3.0 | 0.76 | 3.54 | .785 | 10.54 | 0 | 0 | 0.55 | -- | .284 |
| 1.25 | 4.80 | 3.55 | .222 | 0.5 | 1.78 | 3.03 | 3.0 | 0.67 | 3.70 | .819 | 13.62 | 0 | 0 | 0.55 | -- | .220 |
| 1.5 ft | Spur | Dike | | | | | | | | | | | | | | |
| 0.75 | 4.80 | 4.05 | .253 | 0.5 | 2.03 | 2.78 | 4.0 | 1.01 | 3.79 | .733 | 10.54 | 1.5 | .146 | 0.25 | .167 | .380 |
| 1.00 | 4.80 | 3.80 | .238 | 0.5 | 1.90 | 2.90 | 4.0 | 0.95 | 3.85 | .754 | 12.20 | 1.5 | .123 | 0.30 | .200 | .328 |
| 1.25 | 4.80 | 3.55 | .222 | 0.5 | 1.78 | 3.03 | 4.0 | 0.89 | 3.92 | .773 | 13.62 | 1.5 | .110 | 0.30 | .200 | .294 |
| 1.50 | 4.80 | 3.30 | .206 | 0.5 | 1.65 | 3.15 | 4.0 | 0.82 | 3.97 | .793 | 15.30 | 1.5 | .098 | 0.25 | .167 | .262 |
| 2.0 ft | Spur | Dike | | | | | | | | | | | | | | |
| 0 | 4.80 | 4.80 | .300 | 0.5 | 2.400 | 2.40 | 4.5 | 1.35 | 3.75 | .640 | 8.0 | 2.0 | .250 | 0.25 | .125 | .562 |
| 0.25 | 4.80 | 4.55 | .284 | 0.5 | 2.28 | 2.53 | 4.5 | 1.28 | 3.81 | .665 | 8.90 | 2.0 | .225 | 0.35 | .175 | .506 |
| 0.50 | 4.80 | 4.30 | .269 | 0.5 | 2.15 | 2.65 | 4.5 | 1.21 | 3.86 | .686 | 9.85 | 2.0 | .203 | 0.23 | .115 | .457 |
| 0.75 | 4.80 | 4.05 | .253 | 0.5 | 2.03 | 2.78 | 4.5 | 1.14 | 3.92 | .710 | 10.54 | 2.0 | .190 | 0.20 | .100 | .427 |
| 1.00 | 4.80 | 3.80 | .238 | 0.5 | 1.95 | 2.90 | 4.5 | 1.07 | 3.97 | .730 | 12.20 | 2.0 | .164 | 0.25 | .125 | .369 |
| 1.25 | 4.80 | 3.55 | .222 | 0.5 | 1.78 | 3.03 | 4.5 | 1.00 | 4.03 | .751 | 13.62 | 2.0 | .147 | 0.35 | .175 | .330 |
| 3.0 ft | Spur | Dike | | | | | | | | | | | | | | |
| 0 | 4.80 | 4.80 | .300 | 0.5 | 2.40 | 2.40 | 5.0 | 1.50 | 3.90 | .615 | 8.0 | 3.0 | .375 | 0.22 | .073 | .625 |
| 0.25 | 4.80 | 4.55 | .284 | 0.5 | 2.28 | 2.53 | 5.0 | 1.42 | 3.95 | .640 | 8.90 | 3.0 | .337 | 0.12 | .04 | .562 |
| 0.50 | 4.80 | 4.30 | .269 | 0.5 | 2.15 | 2.65 | 5.0 | 1.34 | 3.99 | .664 | 9.86 | 3.0 | .304 | 0.12 | .04 | .507 |
| 0.75 | 4.80 | 4.05 | .253 | 0.5 | 2.03 | 2.78 | 5.0 | 1.26 | 4.04 | .688 | 10.54 | 3.0 | .285 | 0.15 | .05 | .474 |
| 1.00 | 4.80 | 3.80 | .238 | 0.5 | 1.90 | 2.90 | 5.0 | 1.19 | 4.09 | .710 | 12.20 | 3.0 | .246 | 0.20 | .07 | .410 |
| 1.25 | 4.80 | 3.55 | .222 | 0.5 | 1.78 | 3.03 | 5.0 | 1.11 | 4.14 | .732 | 13.62 | 3.0 | .220 | 0.20 | .07 | .367 |
| 1.50 | 4.80 | 3.30 | .206 | 0.5 | 1.65 | 3.15 | 5.0 | 1.03 | 4.18 | .754 | 15.30 | 3.0 | .196 | 0.20 | .07 | .327 |
| 4.0 ft | Spur | Dike | | | | | | | | | | | | | | |
| 0 | 4.80 | 4.80 | .300 | 0.5 | 2.40 | 2.40 | 6.0 | 1.80 | 4.20 | .571 | 8.0 | 4.0 | .500 | 0.13 | .025 | .750 |
| .25 | 4.80 | 4.55 | .284 | 0.5 | 2.28 | 2.53 | 6.0 | 1.70 | 4.23 | .598 | 8.90 | 4.0 | .450 | 0.05 | .012 | .675 |
| .50 | 4.80 | 4.30 | .269 | 0.5 | 2.15 | 2.65 | 6.0 | 1.61 | 4.26 | .622 | 9.86 | 4.0 | .405 | 0.07 | .018 | .609 |
| .75 | 4.80 | 4.05 | .253 | 0.5 | 2.03 | 2.78 | 6.0 | 1.52 | 4.30 | .647 | 10.54 | 4.0 | .379 | 0.20 | .050 | .570 |

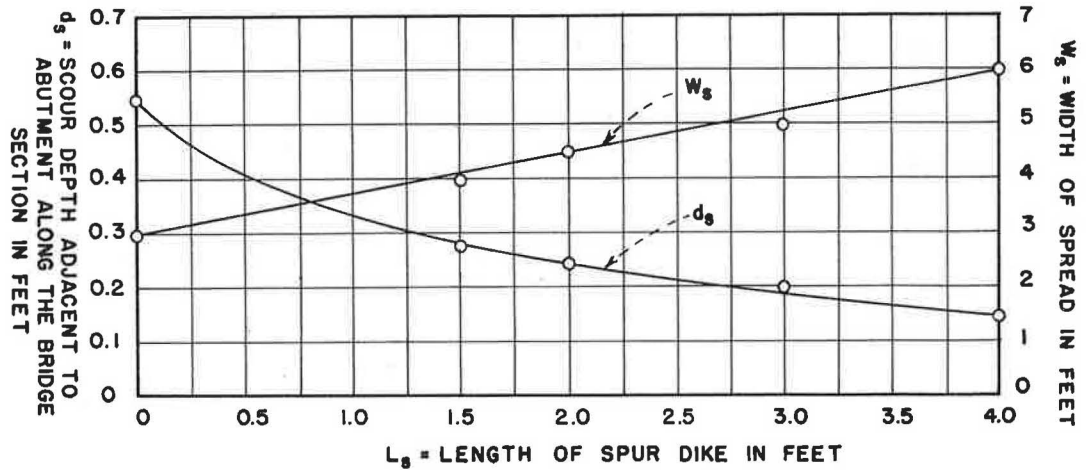
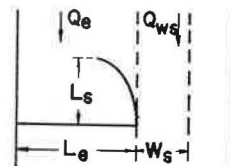
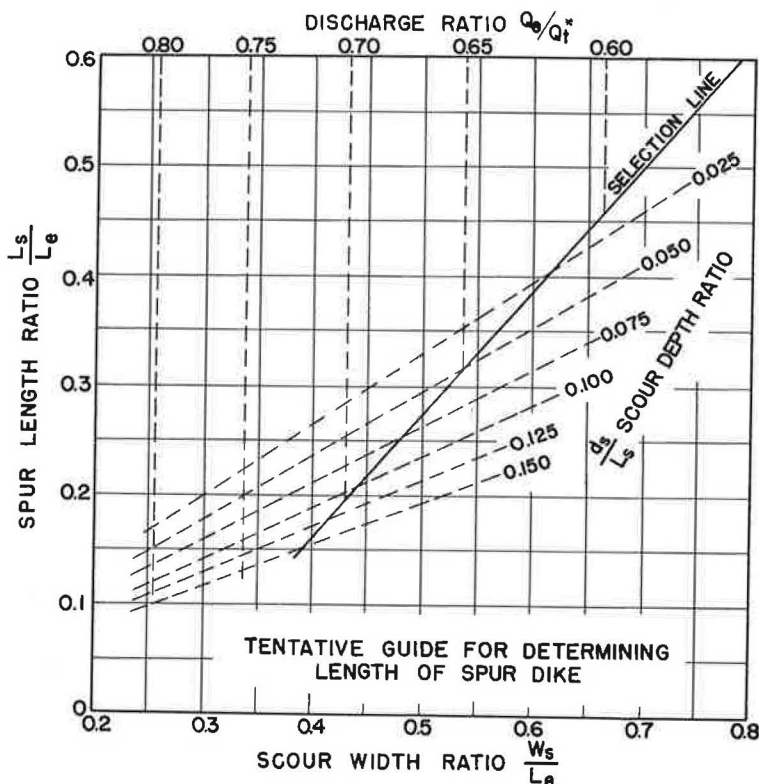

Figure 10. Effect of spur dike length on scour depth and width of spread.

scour depth at the bridge and distribution of the concentrated flow through the bridge opening. As the length of spur dike increases, there is an increase in the width of spread of the concentrated flow. This leads to a reduction in local velocity which results in smaller depths of scour.

Based on the results in Figure 10 and the limited data from the study, a tentative guide for determining the length of spur dike is shown in Figure 11. A trial and error method must be used. At any given stream crossing it is assumed that the length of the roadway embankment and flood discharge are known. It is further assumed that a distribution of flow in the channel can be determined. The chart should be applied to conditions where distribution of flow is fairly uniform over the entire width $L_e + W_s$ (Fig. 2) and for normal embankments. Since it is in the interest of economy to construct the shortest length of dike necessary, the minimum value of L_s/L_e of 0.15 will be tried. With this value, calculate L_s . From d_s/L_s given from the selection line corresponding to the value of L_s/L_e , calculate d_s . If d_s appears excessive, a larger value of L_s/L_e should be tried. When an acceptable value of d_s is determined, the value of W_s/L_e on the abscissa corresponding to the selected L_s/L_e is read from the selection line. The width of spread W_s , is calculated and Q_{ws} is determined. The value of Q_{ws} is the quantity of flow which is approaching W_s normally. Knowing L_e , Q_e is estimated. Q_t^* , the sum of Q_e and Q_{ws} , is determined and the ratio Q_e/Q_t^* is computed. This value is then compared to the value of the abscissa given along the top of the chart. If Q_e/Q_t^* is greater than, or equal to, the value given, the trial length of spur dike is satisfactory.

There is a limit of L_e , the roadway embankment length, to which this chart should be applied. Since the tentative minimum spur length ratio, L_s/L_e , is 0.15 roadway lengths of about 1 mile would give an impractically long spur dike. Generally it is



Instructions For Use

1. Try L_s/L_e .
2. Calculate d_s from Selection Line.
3. Calculate W_s .
4. Determine Q_e/Q_t^* if not satisfactory try another value of L_s/L_e and repeat.

NOTES:

1. $Q_t^* = Q_e + Q_{ws}$
2. This chart applies to Spill-through abutments and normal roadway embankments

Figure 11.

not good design practice to construct a road embankment longer than 2,000 or 3,000 ft on a flood plain without providing a relief bridge. For L_e of 2,000 ft, L_s would be 300 ft—which is not excessive. Consideration of the discharge ratio will somewhat offset this limitation.

Figures 12 and 13 show the effect of an earth embankment spur dike with a 45° wing wall abutment. Because the abutment is vertical, there is a discontinuity of the flow boundary from the spur dike to the abutment. A partial transition is formed by the wing wall but it is insufficient to effect smooth flow conditions, and a secondary flow disturbance is created at the intersection of the wing wall with the abutment. The effectiveness of the spur dike is nevertheless clearly demonstrated. The principal requirement in construction is that the toe of the spur dike should be tangent to the vertical face of the abutment.

A limited number of tests were made with full bridge models to determine the effect of spur dikes on small bridges. These tests were conducted by installing two roadway embankments of equal length on opposite sides of the flume. The roadway lengths were increased successively so that the scour holes which formed at the abutments were made to overlap. As expected, when the scour holes overlapped, there was an increase in depths of scour at the bridge. This indicated that the bridge opening was too small to convey the total discharge. The results also indicated that so long as the bridge was sufficiently longer than the added W_s at both abutments, Figure 11 could be used to determine required spur dike lengths. However, it was observed that when the length of bridge was approximately equal to the sum of W_s at both abutments as determined from Figure 10, the actual W_s which occurred in the flume was less than that originally estimated. This was attributed to the influence of flow from the opposing side which tended to streamline the flow in a shorter width. The smaller W_s resulted in greater d_s . Thus it was necessary to increase L_s to offset the smaller W_s and to reduce d_s . The additional increase in L_s required for short bridges of the latter category could not be established in the form of criteria because of the limited data.

Frequently road alignments are set to cross stream channels at a skew. This may be necessitated by a number of things, highway alignment standards, economics of right-of-way, and cities. Whatever the reason for the skew, the hydraulics of flow will necessitate an adjustment in the spur dike length as determined for normal crossings. Some tests were conducted to give general indications of the skew effects. Only 45° skews upstream and downstream were tested with various spur dike lengths and with a contraction ratio of 0.50.

Figure 14 shows that shorter spur dikes can be used for abutments skewed downstream and longer spur dikes are necessary at abutments skewed upstream than



Figure 12. Scour at a 45° wing wall abutment. $Q_e = 2.40$ cfs $Q_t = 4.80$ cfs $L_o = 8.0$ ft. The top of the black painted area is the original stream bed. Contour interval is 0.1 ft.

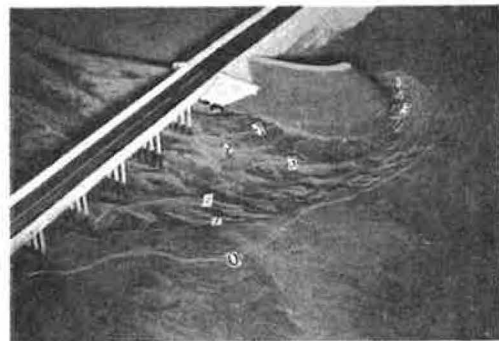

Figure 13. Effect of spur dike on reduction of scour at the bridge with a 45° wing wall abutment. $\lambda = 2\frac{1}{2}$ $L_s = 2.0$ ft $Q_e = 2.78$ cfs $Q_t = 4.80$ cfs $L_o = 8.0$ ft.

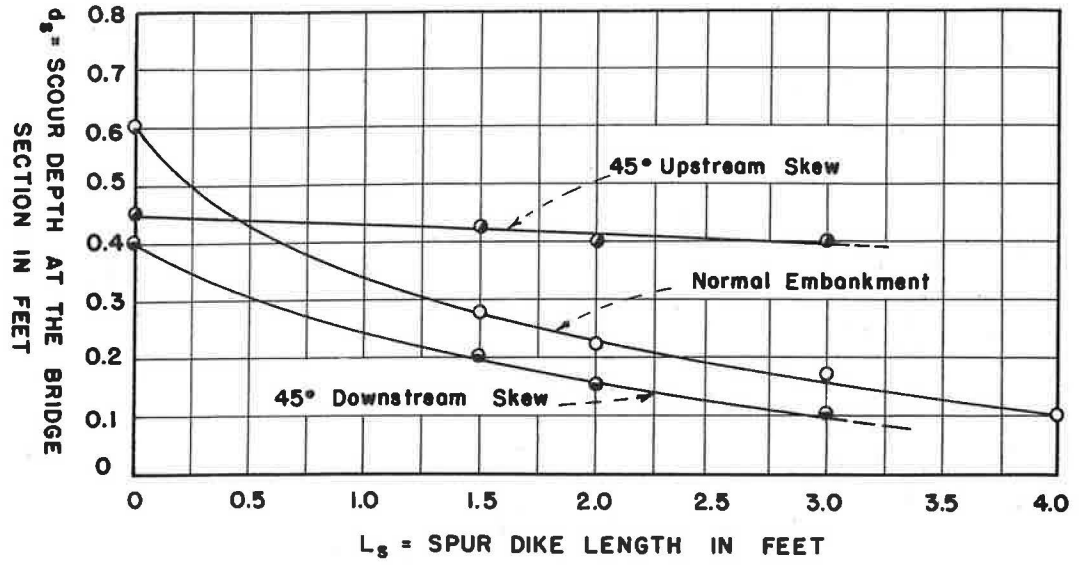

Figure 14. Effectiveness of spur dikes for different embankment skews.

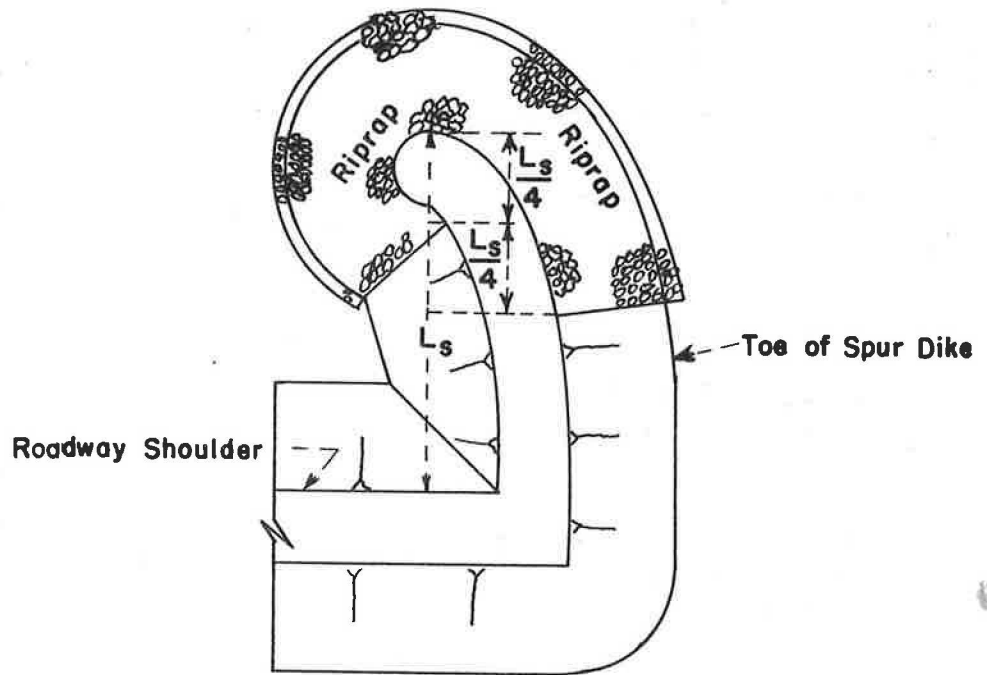

Figure 15. Diagram to show extent of riprap protection on spur dike.

required for normal bridges. Within the limits of the test, where 3-ft spur dikes showed significant reduction of scour both for normal and downstream skews little reduction of scour is noted for the upstream skew condition. The effect of spur dikes on scour reduction for normal embankments is sudden and significant while for downstream skews the effect is rather gradual.

The results of tests with skewed embankments are not incorporated with the tentative design chart because of the limited data collected.

Spur dikes constructed of earth embankment will normally require riprap protection to prevent scour of the dike itself. The laboratory study was made to determine where riprap was required. It was found that about one-half of the spur dike length from the end of the dike on the front or bridge side and about one-fourth on the back side required protection (Fig. 15). The riprap should be extended out from the toe of the dike on the flood plain so that as the scour hole forms, the riprap will fall into place on the side of the scour hole to prevent undermining of the spur dike.

RESEARCH NEEDED

The study has served to point out many aspects of the total problem which needs further investigation. There is a conspicuous need to determine the time relationship between small-scale movable bed studies conducted in the laboratory and the prototype counter parts. Without specific knowledge of this time scale, it is difficult to relate quantitatively certain model phenomena to field behavior. This relationship can perhaps be established by experimentation with larger scale models and eventually correlating with prototype data.

Additional studies are required to determine the length requirements of spur dikes to protect small bridges. The problem of skewed bridges was only touched upon in this study. Additional information is needed to indicate the effect of skew angle on the increase or decrease in the spur dike length. A very important consideration in any scour problem is the effect of sediment in the flow. Although this research was limited to clear water, in the actual case it is probable that floods have a large concentration of suspended sediment in the flow. It is desirable to know whether the suspended sediment increases or decreases the amount of scour at the abutment. The effect of bed movement is another aspect of the problem which needs investigation. With general movement of the bed, the scour hole may not extend as deeply as it does for conditions involving no bed movement. Studies should also be made to determine the effects of routing complete flood hydrographs through the bridge opening to include effects of suspended sediment and bed load movement. This study will involve knowledge of the time scale to conduct properly the laboratory studies. These few suggestions show that this study on spur dikes is only the beginning; much additional research is needed for a better understanding of the total problem.

CONCLUSIONS

The study of spur dikes has resulted in tentative guides for design. Although specific guides were developed only for normal embankments, a general guide is presented for skewed conditions. It was also indicated that small bridges designed with minimum openings required longer dikes than bridges with longer openings.

The limitations of the laboratory study prevent explicit use of the design curve. The study has served to determine the following conclusions:

1. Spur dikes are effective measures to reduce scour at bridge abutments.
2. The effectiveness of spur dikes is a function of the geometry of the roadway embankments, flow on the flood plain, and size of bridge opening.
3. The proper location for an earth embankment spur dike is at the abutment with the slope of the spur dike tangent to the slope of the abutment.
4. The curved spur dikes are more efficient than straight spur dikes because of the smoother streamlining of the flow.
5. Additional research is necessary to establish better criteria for design.