

# HIGHWAY RESEARCH RECORD

Number | New Transportation Systems  
397 | and Technology

7 reports  
prepared for the  
51st Annual Meeting

Subject Area

84 Urban Transportation Systems

## HIGHWAY RESEARCH BOARD

DIVISION OF ENGINEERING NATIONAL RESEARCH COUNCIL  
NATIONAL ACADEMY OF SCIENCES—NATIONAL ACADEMY OF ENGINEERING

Washington, D.C.

1972

## NOTICE

The studies reported herein were not undertaken under the aegis of the National Academy of Sciences or the National Research Council. The papers report research work of the authors done at the institution named by the authors. The papers were offered to the Highway Research Board of the National Research Council for publication and are published herein in the interest of the dissemination of information from research, one of the major functions of the HRB.

Before publication, each paper was reviewed by members of the HRB committee named as its sponsor and was accepted as objective, useful, and suitable for publication by NRC. The members of the committee were selected for their individual scholarly competence and judgment, with due consideration for the balance and breadth of disciplines. Responsibility for the publication of these reports rests with the sponsoring committee; however, the opinions and conclusions expressed in the reports are those of the individual authors and not necessarily those of the sponsoring committee, the HRB, or the NRC.

Although these reports are not submitted for approval to the Academy membership or to the Council of the Academy, each report is reviewed and processed according to procedures established and monitored by the Academy's Report Review Committee.

ISBN 0-309-02069-7

Price: \$2.40

Available from

Highway Research Board  
National Academy of Sciences  
2101 Constitution Avenue, N.W.  
Washington, D. C. 20418



# CONTENTS

FOREWORD . . . . .	iv
PEOPLE MOVERS: PLANNING AND POTENTIALS Herbert S. Levinson . . . . .	1
PRACTICAL REQUIREMENTS FOR ADVANCED PUBLIC TRANSPORTATION SYSTEMS William H. Avery . . . . .	12
Discussion William H. T. Holden . . . . .	23
Author's Closure . . . . .	25
METRO GUIDEWAY: AN INTEGRATED URBAN TRANSPORTATION SYSTEM Eugene T. Canty . . . . .	26
BUXI: DEMAND-RESPONSIVE BUS EXPERIENCE IN THE NETHERLANDS Geurt Hupkes . . . . .	38
OPERATIONAL EXPERIENCES WITH DEMAND-RESPONSIVE TRANSPORTATION SYSTEMS Daniel Roos . . . . .	42
EXTERNAL COMBUSTION ENGINES: PROSPECTS FOR VEHICULAR APPLICATION Roy A. Renner . . . . .	55
DEFORMABLE MESH MOVING BELT AS AN ACCELERATING-DECELERATING DEVICE Robert U. Ayres and Robert Malone . . . . .	63
SPONSORSHIP OF THIS RECORD . . . . .	72

## FOREWORD

The papers in this RECORD focus primarily on the development of potential new systems for the improvement of urban transportation systems.

Levinson discusses the application of people movers or microsystems to the problems of circulation in major activity centers. He states, "New microsystems will improve the accessibility and amenity within major activity centers forming parts of multilevel cities with physically separate transit, pedestrian, goods, and automobile traffic."

Avery analyzes urban transportation alternatives and shows that public transportation can be competitive in speed and convenience with the automobile. A comparison of direct community financial costs for transportation systems fulfilling requirements projected for Baltimore in 1980 is given to illustrate that a bus system offering good service is more expensive than the automobile-based system but that a simple automatic system could produce substantial savings.

Canty describes an integrated urban transportation system called Metro Guideway. The system can provide an automated roadway network accommodating dual-mode automobiles, personal rapid transit and group rapid transit vehicles, and automated freight carriers. Canty suggests that this system might reduce the economic and social costs involved in the development and implementation of new arterial systems.

Two papers review the current experience in the United States and abroad with the development of demand-responsive transportation systems. Roos discusses the operational experiences with demand-responsive systems in Ann Arbor, Michigan; Batavia, New York; Mansfield, Ohio; Columbia, Maryland; Columbus, Ohio; Bay Ridges, Ontario; Emmen, the Netherlands; and Regina, Saskatchewan. These new systems are examined with respect to vehicle dispatching, ridership, economic feasibility, type of service, and overall impact. Hupkes describes the demand-responsive system known as BUXI, which combines features of bus and taxi. BUXI has been in operation in Emmen, the Netherlands, since 1970, and the experience of the operation is discussed by Hupkes.

Renner discusses the external combustion engine as a possible alternative to the internal combustion engine for vehicle propulsion. Renner points out that, based on present experience with the California Steam Bus Project, stream-powered city buses give competitive road performance but they consume more fuel than diesel-powered buses do. Opportunities remain open for evolutionary improvements of thermal efficiency, according to Renner.

Ayres and Malone discuss the problems of people-mover systems in highly congested areas such as densely populated centers of major cities and major termini such as airports. The authors state that, although it is difficult to eliminate all such discontinuities completely, it is possible via their technique to achieve a reasonable final speed (8 to 12 mph) with only a single velocity-interface joint involving a discrete speed change of 1.5 to 2.5 mph in the forward direction only (as with an escalator).

# PEOPLE MOVERS: PLANNING AND POTENTIALS

Herbert S. Levinson, Wilbur Smith and Associates

This paper discusses the role of people movers or microsystems in the urban transport system. It develops performance requirements for people movers based on pedestrian-circulation characteristics and CBD planning needs, and it identifies some of the potential technologies and market applications. Models of the economic trade-off points between bus service and microsystems suggest the desirability of maximizing pedestrian ways and minimizing the extent of automation in most city centers. Ways of accelerating microsystem development on federal and local levels are set forth.

•CONTINUED urban growth has brought a new dimension to urban transportation planning. Revitalization of the nation's city centers and expansion of major airports have placed increased emphasis on pedestrian-oriented movement systems. People movers and microsystems are often incorporated in circulation proposals for major activity centers such as CBD's, airports, college campuses, and urban development complexes. Almost every CBD or airport plan today has its exotic, futuristic technology. Some half century ago, no city was without its electric railway; by the year 2000, no city center will be without its people mover.

Many factors contribute to this increased emphasis on new and innovative transportation technology. The problems of reconciling the automobile with high-density city centers are widely recognized; for many, people movers are the alternative to highways and parking. Conventional public transport services (bus, streetcar, and rapid transit) have difficulty in attracting motorists; buses, in particular, are labor intensive, and bus fares correlate closely with wage rates. There is a growing awareness that the national experience in aerospace technology should be redirected to the solution of key urban transportation problems. On the federal level, the U. S. Department of Transportation has focused more sharply on technology as a complement to other urban transport solutions.

## PEOPLE MOVERS—AN OVERVIEW

People movers or, preferably, microsystems provide short-haul collection and distribution in major activity centers. (All passenger transportation facilities actually are people movers. Thus, people movers include the Queen Mary, Boeing 747, Metroliner, Lexington Avenue Express, Montreal Expo Minirail, 42nd Street Shuttle, and the Empire State Building elevators.) They represent mechanical pedestrian aids that serve relatively short-distance trips—both within the centers and as connectors to other modes. They include continuous (0-headway) and intermittent (variable-headway) systems. They incorporate a variety of guideway systems and propulsion mechanisms, including both active and passive vehicles. They range from automated walkways to birail, monorail, and air-cushion train systems. They generally include automated operations.

### Pedestrian Circulation Characteristics

Pedestrian movement patterns and travel preferences influence microsystem planning, design, and technology. Most pedestrian trips in major activity centers are short in length—usually less than a few blocks. They mainly reflect movements from parking and transit terminals to places of work (or air terminals) and movements among stores

and offices in the retail core or among air terminals, planes, and buildings often to transact business, to eat a meal, or to change planes.

Parking space-to-building or transit stop-to-building trips are more important than trips among buildings. In downtown Seattle, for example, 56 percent of all pedestrian trips were to or from line-haul transportation facilities and 44 percent were among buildings (1). The locations of parking facilities and transit terminals, therefore, have a major influence on the patterns of walking trips within the CBD.

Pedestrian travel is highly concentrated in the downtown retail and commercial cores. Major internal travel movements take place among relatively few areas, usually within the retail shopping area. Half of all person trips and fewer than a third of all internal walking trips to the typical CBD are for work purposes.

Pedestrian volumes are far more localized than transit or automobile passenger flows. Along State Street between Madison and Washington Streets in Chicago's Loop daily sidewalk volumes exceed 80,000 persons; but 3 blocks away between Lake Street and Wacker Drive, the volumes drop to 11,000 persons. Daily crosswalk volumes exceed 25,000 persons along Market Street in Philadelphia's core area but drop to 1,000 persons within 4 blocks. Daily crosswalk volumes exceed 20,000 persons in Seattle's core area but drop to 3,000 persons within 2 blocks. Similar patterns are found in most cities.

The distributions of walking distance are generally consistent among cities of similar size (Fig. 1). In cities such as Pittsburgh and Dallas, median walking distances approximate 500 ft, and the 80 percentile values average 1,200 ft. In Boston, these values increase to 1,000 and 2,000 ft respectively; the increase is partly due to locations of commuter railway stations. Walking distances in midtown Manhattan are even longer because of block spacing and location of subway stations.

### Performance Requirements

Microsystems should be designed for short-distance, high-volume conditions. System length will generally be less than 3 to 4 miles, and passenger rides will be less than a mile. (Most central business districts, for example, are less than 1.5 square miles in area.) Consequently, effective area coverage with high service frequency and close station spacings are more important than high maximum or sustained speeds.

Ideally, service should be constantly available, as it is with belt-based technologies. For intermittent operations, average waiting times should not exceed 2 to 3 min; this implies 5-min maximum headways and 1- to 2-min headways during peak periods.

Station frequency depends on system configuration, land uses served, and technology utilized. Stops on belts at 300- to 800-ft intervals and stops on other systems at 700- to 1,200-ft intervals will usually provide a high degree of service coverage.

Desired service volume (capacity) will vary according to location and type of installation. One-way peak directional capacities of 5,000 persons/hour will meet most requirements. (By 1980, the Seattle-Tacoma Airport Satellite Transit System, for example, is planned to carry 1,200 persons per 5-min peak on loop lines and 175 persons on the shuttle line. Equivalent hourly volumes are 2,400 to 14,000 persons.) Systems should accommodate peak 15-min flow rates that are twice the hourly rate. Stations must be adequately designed for peak loads. (Considerably greater capacities are necessary in Manhattan.) Adequate reserve capacity should be provided for future loading conditions.

The human dimension—the size and spatial requirements of people—influences the minimum cross-sectional requirements of microsystems. People should be able to enter and to leave vehicles in a standing position so that station dwell times are minimized; however, this requirement limits the ability to penetrate existing buildings. Many microsystems have vehicle widths of 7 ft, while rapid transit cars have 8 ft 10 in. widths—a difference in scale that may be minimal when provisions for stations are taken into account [Fig. 2 and Table 1 (2)].

Systems should be capable of being built, should operate safely and reliably, should be environmentally compatible, and should meet general public acceptance. They should minimize vehicle storage requirements in core areas, allow off-line maintenance, permit automated operations, and have capital costs that are less than those for conventional rapid transit.

Figure 1. Walking distances in center city.

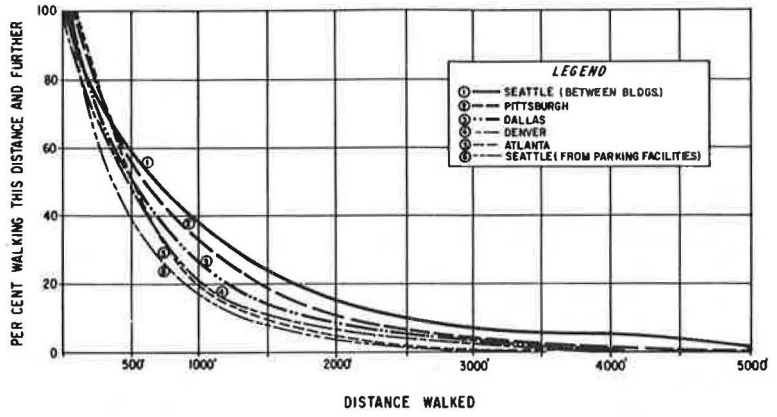

Figure 2. Comparative rapid transit and microsystem cross sections.

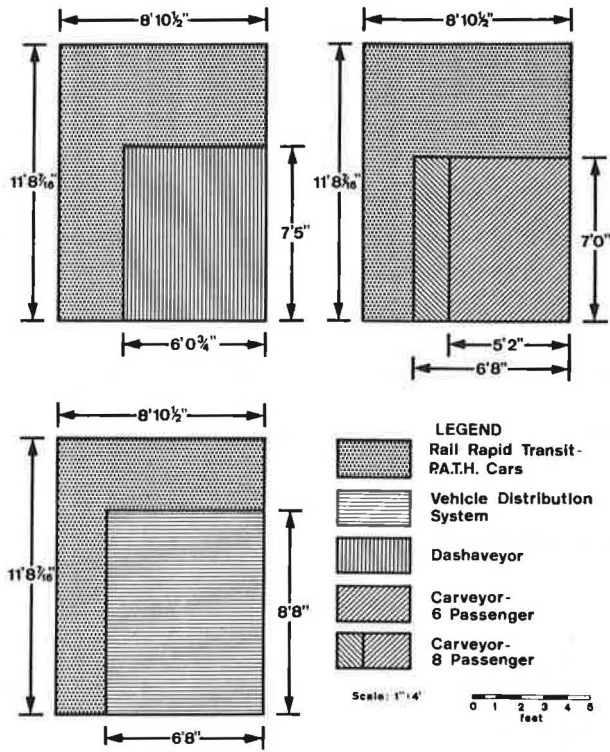

Table 1. Vehicle dimensions for selected transportation technologies.

System	Length (ft)	Width (ft)	Height (ft)
Minibus	20 to 29	8	9 to 10
Bus	25 to 45	8	10 to 11
Rail rapid transit car	50 to 70	8 <sup>5</sup> / <sub>6</sub> to 10	12 to 15
Alweg monorail car	60	10	10
Carveyor	7	5 <sup>1</sup> / <sub>6</sub> to 6 <sup>2</sup> / <sub>3</sub>	7
Dashaveyor	18	6	7 <sup>5</sup> / <sub>12</sub>
Guidomatic bus	45 <sup>a</sup>	5	7 <sup>1</sup> / <sub>2</sub>
Jetrail	11 <sup>1</sup> / <sub>2</sub> to 18 <sup>1</sup> / <sub>4</sub>	6 to 6 <sup>2</sup> / <sub>3</sub>	7 <sup>1</sup> / <sub>2</sub>
Mall bus	40 <sup>b</sup>	8	4 <sup>2</sup> / <sub>3</sub> <sup>c</sup>
Mini-monorail	13	6	6 <sup>c</sup>
Minirail	12	6	6 <sup>c</sup>
Telecanape	40	8	9 <sup>5</sup> / <sub>6</sub>
Transit expressway	30 <sup>1</sup> / <sub>2</sub>	8 <sup>2</sup> / <sub>3</sub>	10
Transportation Technology Incorporated	10	6	N.A.
Westinghouse Vehicle Distribution System	16 to 20	6 <sup>2</sup> / <sub>3</sub>	8 <sup>2</sup> / <sub>3</sub>
WEDway	7	6	4 <sup>2</sup> / <sub>3</sub> <sup>c</sup>

<sup>a</sup>Three-vehicle unit.

<sup>b</sup>Two articulated units.

<sup>c</sup>Precludes entering and leaving vehicles in standing position.



and buildings. Ramps, escalators, and elevators should provide necessary vertical connections.

### Cost-Patronage Comparisons

The feasibility of microsystems in major activity centers depends on many factors that include the ability to attract patronage, to benefit adjacent properties, and to stimulate new investments. Their economic feasibility as an alternative to shuttle bus service also depends on the relation of capital and operating costs to existing or anticipated patronage levels. Accordingly, illustrative cost comparisons were developed to identify the ranges in break-even bus volumes and microsystem development. Illustrative cost comparisons are shown in Figure 3 for a 30-passenger bus as compared with an automated microsystem. Table 2, in turn, gives the range in break-even passenger volumes for 30- and 50-passenger buses under a variety of operating conditions. This comparison of the combined capital and operating costs per passenger mile (including amortization) for various assumed passenger loadings does not reflect direct user benefits or ancillary land use benefits that could result from microsystem development.

Assumptions of the analysis are as follows:

1. Thirty-passenger buses are in continuous operation on the route, 8 hours/day, 6 days/week (Table 2 also gives break-even points for 50-passenger buses);
2. All bus passengers are seated, and additional buses are introduced into service to meet demands;
3. Bus service life is 15 years, and capital costs are about \$35,000/bus;
4. Bus operating costs range from \$0.70 to \$1.20/bus-mile, and bus operating speeds are about 6 mph;
5. Microsystem service life is 40 years;
6. Microsystem operating cost is \$0.01/passenger mile;
7. Interest rates are 6 percent for debt service (amortization) of buses and microsystems;
8. Average passenger loadings per mile of route are uniform;
9. Peak-hour dominant 1-way flow averages 10 percent of the daily (8-hour) 2-way flow (thus, the peak-hour 1-way flow would average 20 percent of the 8-hour 1-way flow); and
10. Comparable fares are charged on both services (this assumption did not enter the computations).

The cost-model comparisons clearly identify the need for high-volume pedestrian corridors to make microsystems more economical than buses. (There is, of course, considerable variability resulting from alternative peak, service, and construction cost assumptions.) For example, if bus operating costs are \$1.20/mile, then

1. Construction costs of \$2 million/mile would require an average 8-hour volume of 8,000 to 13,000 persons/mile of route (these volumes are common in the downtown areas of cities, such as Pittsburgh and Atlanta, having populations of more than 500,000);
2. Construction costs of \$5 million/mile would require an average 8-hour passenger volume of 20,000 to 32,000 persons/mile of route (these volumes are found only in core areas of cities such as Atlanta and Pittsburgh); and
3. Construction costs of \$15 million/mile would require an average 8-hour passenger volume of 60,000 to 96,000 persons/mile of route (these volumes are found only in the core areas of the largest city centers such as Chicago and New York and represent peak-hour 1-way flows that exceed the capacities that can be realistically provided by buses operating on arterial streets).

### Walking Distance Factors

The distances in which intermittent microsystems can provide time savings over walking are given in Table 3. Movement distances of 700 to 1,000 ft or more are required for microsystems to make trip times significantly less than they would be by walking. These distances are longer than most pedestrian trips within major activity centers.

Figure 3. Microsystem and passenger bus cost comparisons.

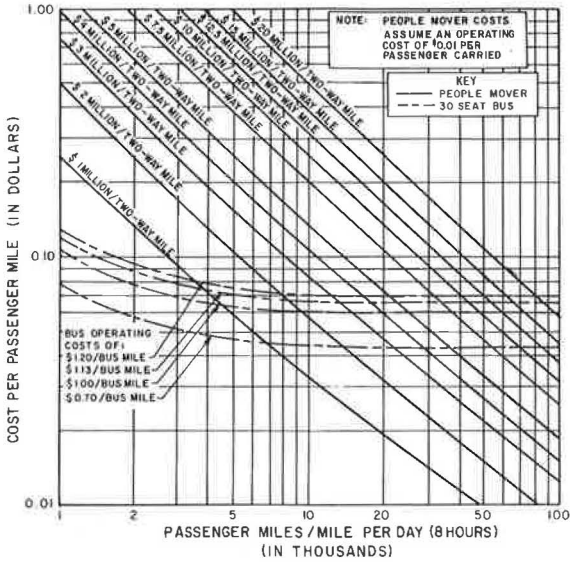

Table 2. Break-even passenger bus volumes and microsystem capital costs.

Microsystem Capital Cost/2-Way Mile <sup>c</sup> (\$ millions)	Passenger Mile/Route Mile <sup>a</sup> by Bus Type					
	30-1 <sup>b</sup>	30-2	30-3	50-1 <sup>c</sup>	50-2	50-3
1	7,000	4,800	4,000	12,000	8,000	6,400
2	14,000	9,600	8,000	24,000	16,000	12,800
5	35,000	24,000	20,000	60,000	40,000	32,000
10	70,000 <sup>d</sup>	48,000 <sup>d</sup>	40,000 <sup>d</sup>	120,000 <sup>d</sup>	80,000 <sup>d</sup>	64,000 <sup>d</sup>
15	105,000 <sup>d</sup>	72,000 <sup>d</sup>	60,000 <sup>d</sup>	180,000 <sup>d</sup>	120,000 <sup>d</sup>	96,000 <sup>d</sup>

Note: Operating cost of microsystem per passenger mile (i.e., per passenger earned) is \$0.01; interest rate is 6 percent; and service life is 40 years for microsystem and 15 years for bus.

<sup>a</sup>8-hour period.

<sup>b</sup>30 passenger bus operating at \$0.70 (30-1), \$1.00 (30-2), and \$1.20 (30-3) per bus mile.

<sup>c</sup>50-passenger bus operating at \$0.70 (50-1), \$1.00 (50-2), and \$1.20 (50-3) per bus mile.

<sup>d</sup>Results in peak-hour flow that exceeds capacity that can be provided by bus operating on arterial streets.

Table 3. Minimum distances at which trip time will be less by bus or microsystem than by walking.

Type of Service	Distance Traveled (ft)		
	On Microsystem or Bus	To and From Microsystem or Bus	Total
Minibus at 6 mph			
3-min headway	410	300 to 500	710 to 910
5-min headway	680	300 to 500	980 to 1,180
Microsystem at 12 mph			
3-min headway	325	500 to 700	825 to 1,025
5-min headway	540	500 to 700	1,040 to 1,240

## Candidate Technologies

More than 125 candidate microsystem technologies have been proposed within the past several years. Those technologies are in varying stages of development. Some are in service at fairs or airports; others are fanciful ideas from basement workshops or drawing boards. Although there is an abundance of concepts, comparatively few new systems are in actual revenue service.

A review of the various concepts for technical feasibility, operational workability, environmental compatibility, developmental status, and relevance to transportation needs of major activity centers substantially reduces the potential candidates. Many proposals constitute operational modifications of existing technologies; some involve unduly complicated suspension propulsion systems; others appear better suited for intercity travel than for short-haul, readily available service (3). Most existing or planned installations represent loop or shuttle systems that do not require fast-acting on-line switches.

Technologies that may become available for application in major activity centers within 5 years fall into 3 broad categories: (a) new types of buses or similar multi-passenger vehicles operating on existing streets, (b) beltlike systems operating continuously and always available for passengers to board, and (c) train or fixed-guideway vehicles.

Bus types and propulsion technologies include the standard internal combustion engine bus, modified to reduce emission of pollutants; the gas turbine bus; the liquid natural gas bus; and the electric (battery) bus. Prototypes of the electric bus are being tested in revenue service in Germany.

Continuous microsystem technologies include moving belts, escalators, and variable-speed systems. Moving belts are currently operating in many airports, e.g., at the San Francisco International and Love Field in Dallas, and at the San Diego Zoo. Construction costs approximate \$350 to \$500/linear foot. Variable-speed systems include WEDway, which is operating at Disneyland, and Carveyor and Transpallet, which are in development.

Intermittent systems include (a) the Skybus, operating experimentally at South Park near Pittsburgh and at the Tampa Airport and being installed at the Seattle-Tacoma Airport; (b) the minirail, operating at the Montreal, Munich, and Lusanne Expositions; (c) smaller scaled monorail system such as the Jetrail, operating at Love Field in Dallas; (d) personalized dual-rail system, such as the one being considered for the new Dallas-Fort Worth Regional Airport; and (e) air-cushion system, such as the one proposed by Transportation Technology, Inc.

## PLANNING GUIDELINES

The installation of microsystems should be selective within the broader context of regional transportation and major activity center pedestrian plans. Regional transportation facilities must provide the basic framework for circulation and distribution systems. Economic and environmental feasibility will strongly influence system installation.

### Design and Locational Factors

Microsystems should be physically separated from other movements wherever possible and protected from unauthorized use. They can traverse public rights-of-way or append or penetrate buildings. They can be located above or below grade.

Routes should be planned to provide the maximum service in the minimum distance, i.e., to carry the maximum number of passengers per mile of route. They should serve, rather than bypass, major retail and office concentrations. They should follow direct, linear movement channels whenever possible. They should avoid excessive branches and complex routing patterns. They should complement rather than compete with line-haul transit services.

Stations should be integrated with line-haul rapid transit stops, major parking complexes, and pedestrian ways. They should be easily accessible from pedestrian ways



Data given in Table 3 are based on the following formula:

$$Z = [W(V_m V_w)] / (V_m - V_w)$$

where

- Z = distance traveled on microsystem or bus;
- W = waiting time, assumed to be  $\frac{1}{2}$  headway between successive units, sec;
- V<sub>w</sub> = average travel speed for person walking, including delay time at intersections, ft/sec; and
- V<sub>m</sub> = average travel speed for microsystem or minibus, and including stops for passengers and traffic delays, ft/sec.

The following values were assigned to the variables: V<sub>w</sub> = 3 ft/sec; V<sub>m</sub> = 8.8 ft/sec (6 mph) for minibus in traffic with 1 stop per block; and V<sub>m</sub> = 17.6 ft/sec (12 mph) for grade-separated microsystem with 1 stop per block.

### Pedestrian Ways and Microsystems

The foregoing factors suggest that emphasis should be placed on maximizing the number of key pedestrian corridors (in relation to and as a stimulus for new development) and on minimizing the extent of pedestrian-way automation in most activity centers.

Primary attention should be directed to reserving pedestrian-movement corridors through proposed development complexes and to extending those corridors as buildings are modernized. Design of pedestrian-movement corridors should allow for future incorporation of existing or new microsystem technologies as demands arise and technologies are further developed.

Building codes and zoning ordinances could be modified to encourage redesign of existing buildings and design of new developments to provide or reserve pedestrian-movement channels. Advance acquisition of rights-of-way for pedestrian-movement corridors should be encouraged.

### MARKET POTENTIALS

There are many emerging opportunities for microsystems in the nation's large urban centers. The location, type, and intensity of present and future developments, the expected interaction among major activity concentrations, and the community's desire to minimize fractionated parking developments influence development prospects. Factors favorable to microsystem development include extensive core-area congestion (both street and sidewalk), limited parking in core areas, major movement barriers within or near the activity center, rapid center city growth, and available movement corridors. The high capital costs of microsystems suggests the need to serve heavy pedestrian concentrations or to offset initial investments as part of redevelopment, renewal, or airport expansion projects or to do both.

### Airports

Airports represent an excellent potential for microsystems. They produce relatively high passenger demands per unit of construction, provide commonality of ownership, and have minimum environmental constraints. Moreover, an airport is perhaps the fastest growth center in the urban setting and often makes ample resources available for pedestrian-related amenities. Airport parking revenues are substantial and could be used to help finance microsystems. Connections between satellite terminals and principal passenger facilities are especially conducive to microsystem development.

The Jetrail at Love Field and the Skybus at the Tampa Airport and the Seattle-Tacoma Airport represent existing installations. An illustrative microsystem plan for John F. Kennedy Airport is shown in Figure 4.

## Central Business District

The best potentials for microsystems in downtown areas exist in large-scale urban development complexes where the systems can be integrally incorporated into overall development plans. Land assembly under a single developer can expedite consensus on microsystem design, locations of access points, and identification of beneficiaries. Construction costs can be shared with adjacent land uses, thereby providing a broader financial base for system rationalization. Routes and stations can be incorporated within building complexes. Size and spatial requirements of stations can produce a serious environmental constraint when stations are located in street rights-of-way (Fig. 5). The weight and vertical clearance requirements within buildings suggest special treatments for those floors or levels that incorporate microsystems. Buildings can be grouped to provide the desired horizontal and vertical alignment. Linear urban development complexes, such as the White Plains Urban Renewal Project, are especially adaptable to microsystem developments. Proposed urban development complexes such as Battery Park City in New York and Harbor Square in Toronto also would benefit from microsystems.

The greatest potentials for microsystems in existing downtown areas are in New York City. Manhattan has several major corridors with sufficient concentrations of pedestrian movements to warrant extensive capital investments, for example, the 48th Street Midtown Distribution System proposed by the Metropolitan Transit Authority.

## ACCELERATING MICROSYSTEM DEVELOPMENT

Realization of microsystem potential calls for resourceful public and private approaches in development. The small scale and localized impacts of many systems as well as the many public and private groups involved often have deterred implementation. Similarly, technological innovation in microsystem development should be accelerated through cooperative federal, local, and industry efforts.

### Labor Implications

Many applications will represent new services that will not reduce employment on existing transit systems. Some new automated installations, however, may replace existing labor-intensive facilities; this transition should occur gradually to ease the displacement of existing employees in general accord with Section 13(c) of the Urban Mass Transportation Act of 1964 as amended.

### Codes, Safety, and Insurability

New technologies should meet commonly accepted safety standards and conform to existing safety codes. Insurance underwriters will generally not insure any system that violates local codes. The more a system deviates from the safety codes, the less likely it is to be insurable except, perhaps, at a very high premium by an underwriter specializing in high-risk coverage.

The American Standard Safety Code for Elevators, Dumbwaiters, and Escalators (ASSC) is prepared by the American Society of Mechanical Engineers in cooperation with representatives of manufacturers, insurance carriers, regulatory agencies, and technical societies. Although the document itself is advisory and has no legal significance, it has been formally adopted by many local governments as their legal code governing the use of such systems. In 1965, the ASSC added moving walks to its contents; the Code limits entry and exit to the beginning or end of the moving walk, generally requires a handrail along each travel lane, and limits the maximum speed to 180 ft/min in level operation.

### Research Needs

Research and experimentation should be an iterative process focused on refining human engineering factors and design parameters; pinpointing service applications and cost limits; improving system components, performance capabilities, and environmental qualities; and identifying benefits and payoffs.

Figure 4. Microsystem plan for John F. Kennedy International Airport.

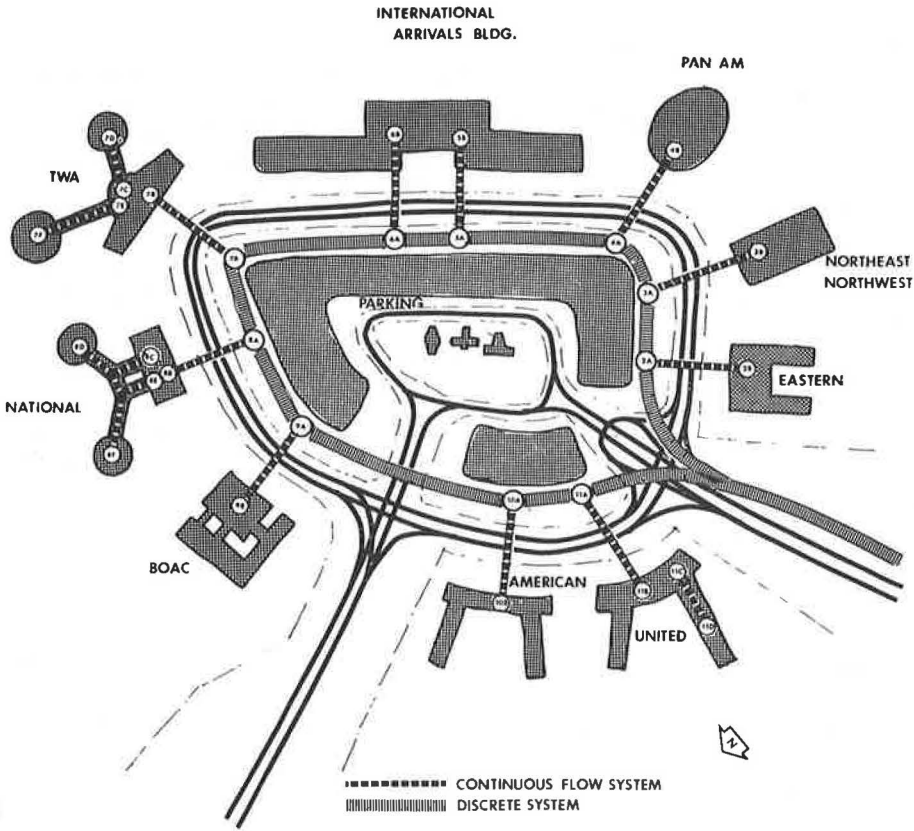
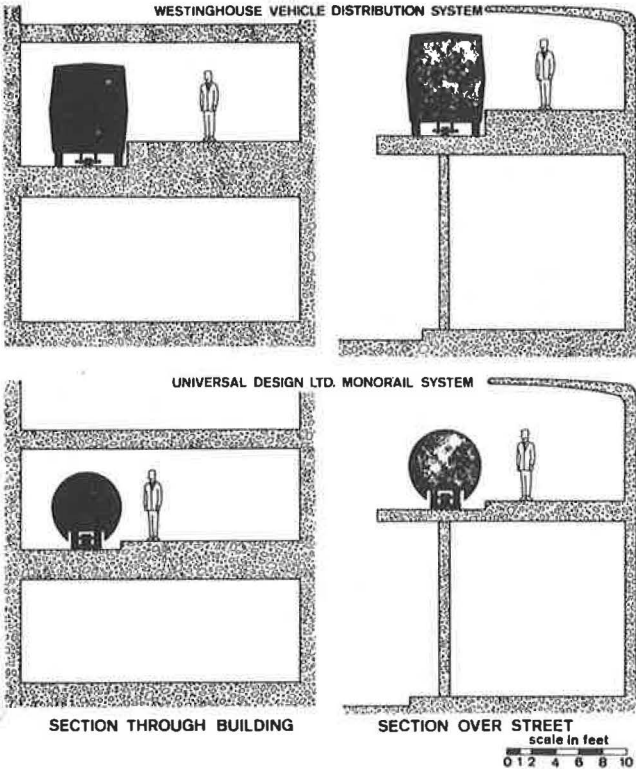

Figure 5. Microsystem station design alternatives.



There is need to obtain more precise information on the costs and operating capabilities of proposed systems. The differences between actual and simulated performance should be identified; much has been said about new urban transportation technologies, but there is little factual data on the engineering and cost characteristics of most proposals. Many systems have operated only in amusement parks or fairs where there is ample shutdown time available for maintenance and repairs. In those cases, there are no serious public impacts when the systems are inoperative for maintenance purposes.

There is a need to balance investments in limited-purpose systems against those serving regional or area-wide functions. The cost of a 2-mile microsystem in Denver, for example, would exceed that of acquiring the 200-vehicle bus system (estimated at \$7.5 to \$10 million).

There is need to balance the major problems of costs, environmental compatibility, and diversity of demands. At-grade or above-grade construction would reduce installation costs but requires sensitive design to overcome environmental conflicts. Penetrating buildings may be desirable where buildings have the desired structural capability and collinearity, or where pedestrian systems can be incorporated in new developments. Cost reduction is essential to maximize development potentials.

Additional study is needed on the trade-offs among costs, headways, patronage levels, and station spacing. There is need to identify optimum service frequencies, system lengths, and station spacing in relation to specific urban needs.

### Research Directions

Research efforts on near-term microsystem technologies should be directed toward the following:

1. Buses with less noise and exhaust pollution emissions and with better loading systems. More extensive research on noise and pollution reduction is essential. Gas turbine and liquid natural gas propulsion systems for buses may offer some promise. Additional testing of electric and other nonpollutant engines is also desirable, especially where underground operations are involved.

2. Differential-speed, moving-belt systems that negotiate grades and curves. The continuous-motion character of the moving-belt technology is especially suitable for short-distance, high-volume center city situations.

3. Fixed-guideway systems with small and lightweight vehicles capable of train operations, reduced cross sections and structural requirements, and simplified support, suspension, and switching mechanisms. Systems could be designed for line-haul or distribution functions or both and represent a synthesis of rapid transit and microsystem services. Peak-hour, 1-way capacities ranging from 10,000 to 15,000 persons/hour would prove adequate for most urban situations. Safe, reliable, and quick-acting switches are essential to effectively serve single vehicles or trains or both operating at short headways. The current federal efforts toward developing personal rapid transit vehicles is an important step in this direction.

4. Improved control mechanisms. Design of reliable, reasonably priced control systems is essential for short-headway microsystems (4).

### Cooperative Experimentation

The federal government should encourage and support research and experimentation with new transportation technologies. This may necessitate full federal funding of new systems as prototype demonstrations within center cities. Cities are confronted with a wide array of social and economic problems; they are unwilling and unable to experiment with new or unproven systems. Federal funding could serve to help reorient local efforts and reduce the barriers to innovation. A leading rather than reactive approach is required.

This calls for a federal proving ground for new technologies or substantive assistance to manufacturers or both and pilot installations in selected cities with costs borne by federal agencies or shared with cities and system suppliers. (The Morgantown, West Virginia, and Dulles International Airport personal rapid transit demonstration projects,



sponsored by the U. S. Department of Transportation, are important steps in this direction.) Adequate lead time is essential because 5 or more years will probably be required before new technologies are operational.

#### IN PROSPECT

New microsystems will improve the accessibility and amenity within major activity centers. In multilevel cities, they will form parts that physically separate transit, pedestrian, goods, and automobile traffic. Climate-controlled skywalks, plazas, and microsystems will provide a new dimension to pedestrian mobility and amenity.

As new transport technologies are developed and as implementation capabilities are strengthened, new levels of mobility will be achieved. They will help to create an exciting, dynamic, and vital city of the future, fully responsive to the needs and aspirations of the public it serves.

#### ACKNOWLEDGMENTS

Many individuals contributed to the materials contained in this paper. The assistance of Theodore J. Soltman, Paul N. Bay, and F. John Devaney of Wilbur Smith and Associates, Douglas Webb of the New Jersey Department of Transportation, and Franz Gimmler of the Urban Mass Transportation Administration are especially acknowledged.

#### REFERENCES

1. Urban Transportation Concepts. Wilbur Smith and Associates, 1970.
2. Handman, A. L., Bush, R. L., and Bee, R. W. Transportation System Candidates for Center City and Major Activity Center Applications. MITRE Corp., Jan. 1970.
3. Innovations in Center City Transportation Technology. Wilbur Smith and Associates, 1969.
4. Technical Evaluation of Advanced Urban Transportation Systems. Applied Physics Laboratory, Johns Hopkins Univ., Summary Rept., June 1970.

# PRACTICAL REQUIREMENTS FOR ADVANCED PUBLIC TRANSPORTATION SYSTEMS

William H. Avery, Applied Physics Laboratory, Johns Hopkins University

An analysis is given of urban transportation alternatives that shows that public transportation can be competitive in speed and convenience with the automobile. A comparison of direct community financial costs for transportation systems fulfilling requirements projected for Baltimore in 1980 is given to illustrate that a bus system offering good service is more expensive than the automobile-based system but that a simple automatic system could produce substantial savings. A plan for a demonstration to verify this conclusion is suggested.

•RECOGNITION of the destructive impact of the automobile on the quality of urban life has intensified interest by municipal and federal agencies in better public transportation. However, until recently no valid alternative to the automobile could satisfy the public demand for convenient comfortable service and be installed and operated economically. Consequently, urban planning groups and their consultants have generally concluded that public transit can play only a minor role in the total transportation picture, even though it may have significant benefits to the community in easing rush-hour congestion in critical areas, in offering minimal service to those who do not have access to an automobile, and in generating developments that bring tax revenue. In accord with this view, public officials are placing major emphasis on funding rapid transit systems and on refurbishing bus systems. These measures will relieve congestion along some corridors to the urban centers and will prevent the demise of some bus systems but will not stop the growth of automobile traffic because the average traveler will still find that he can get to his destination more directly and more rapidly by driving his automobile than by using the rail or bus system.

Unless transportation systems can be developed that will provide equivalent or better service than automobiles at comparable cost, they will not gain public acceptance. One of the major features of the automobile is its ability to go from any point in the city to any other by a direct route. This ability depends on the existence of a road network that provides close-range access to the entire developed metropolitan area. The fact is well illustrated by the 1980 projected traffic flow in the city of Baltimore shown in Figure 1 (1). The traffic flow lines are seen to cover the entire metropolitan area rather uniformly. The small fraction of total trips directed to the central business district (about 7 percent) is shown in Figure 2. Such patterns are typical of all American cities and demonstrate that public transit must provide area coverage with all regions equally accessible if it is to respond to the transportation needs.

Another major feature of the automobile is its immediate availability compared with the long delays and frustrations involved in conventional public transportation, which is operated with infrequent service and on unreliable schedules.

A third major point about automobile transportation involves its low apparent cost. The automobile driver is concerned primarily with his direct operating costs, which are usually underestimated, and overlooks fixed costs and maintenance. On this basis, automobile travel seems inexpensive, and bus or train fares of more than 5 cents/mile seem excessive to him.

The considerations given above show that public transit, to be competitive with automobiles, must offer

1. Direct access to any point in the metropolitan area (this implies a network of routes similar to the road network);

2. Door-to-door travel time comparable with that of the automobile (this requires a closely spaced grid of lines and stations to permit short walking distance at origin and destination, average line speed equal to or better than automobile speeds in urban travel, and service frequent enough to make waiting time negligible);

3. Low total operating cost (including amortization of installation costs) so that profitable operation of the system will be possible with a fare small enough to attract major public use; and

4. Social and environmental acceptability, including comfort, service to nondrivers, and compatibility with community aesthetic, social, and economic needs.

### SYSTEM DESIGN

Let us now consider the system design requirements to provide the high-quality service discussed above. The grid spacing is the most fundamental factor in defining the system characteristics because it determines the walking distance to the stations, the line capacity needed, the total route mileage, and the practical line speed. If we note that the difference in travel time for a 5-mile trip at 60 mph versus 20 mph is only 10 min and that the same time is required for a walk of  $\frac{1}{2}$  mile, it is clear that the walking distance must be small if door-to-door times of public systems are to compete with automobiles, for which the typical walking and parking time is 2 or 3 min.

For a walking speed of 3 mph and average line speed  $V_T$  including stops, the average door-to-door time  $t_T$  in minutes for the public transportation system is

$$t_T = 20d_w + 60 (d_r/V_T)$$

where  $d_w$  is the walking distance in miles for a complete trip,  $d_r$  is the riding distance in miles, and  $V_T$  is the average line speed.

For automobile travel that requires  $2\frac{1}{2}$  min for walking and parking, the door-to-door time is

$$t_a = 2\frac{1}{2} + 60 (d_r/V_a)$$

where  $V_a$  is the average automobile speed in miles per hour.

Thus, if door-to-door time of public transportation is to equal automobile time for the same trip, we must have

$$d_w = \frac{1}{8} + (3d_r/V_T) [(V_T/V_a) - 1]$$

For a variety of reasons (2),  $V_T$  has a practical upper limit in the range of 40 to 60 mph. Therefore, because, average automobile speed in city driving is in the range of 15 to 25 mph,  $V_T/V_a$  has an upper limit of about 3. Thus, total walking distance  $d_w$  should be  $\frac{5}{8}$  mile or less for an average trip of 5 miles.

The route mileage is determined by the line spacing and the populated area to be served. A grid of routes with spacing of  $L$  miles between lines requires  $2/L$  route miles/square mile. This would give a walking distance somewhat less than  $L$  miles; allowance is made for station location to favor short walks in employment areas and apartment locations.

The average number of vehicles in service depends primarily on the requirement to maintain throughout the populated area a high frequency of service that will effectively eliminate waiting to board or transfer. However, additional vehicles may be necessary to carry the rush-hour peak load in areas of high trip density. Both factors involve the average speed of the vehicle. The number of vehicles needed to provide a headway of  $\Delta t_H$  minutes is

$$N_H = \text{route mileage/vehicle separation} = (120/L\Delta t_H) \Sigma A_i/V_i \quad (1)$$

where  $A_i$  is the area of zone  $i$ ,  $\Sigma A_i$  is the populated area, and  $V_i$  is the average vehicle speed in zone  $i$  in miles per hour. The maximum line capacity occurs on lines entering the CBD or other small zones of high employment density. The rush-hour peak load is

**Figure 1. 1980 travel desires from internal districts to internal districts.**

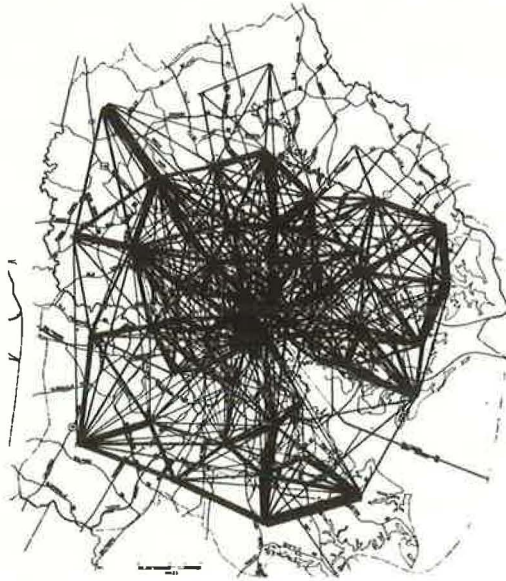

**Figure 2. 1980 travel desires from internal districts to CBD.**

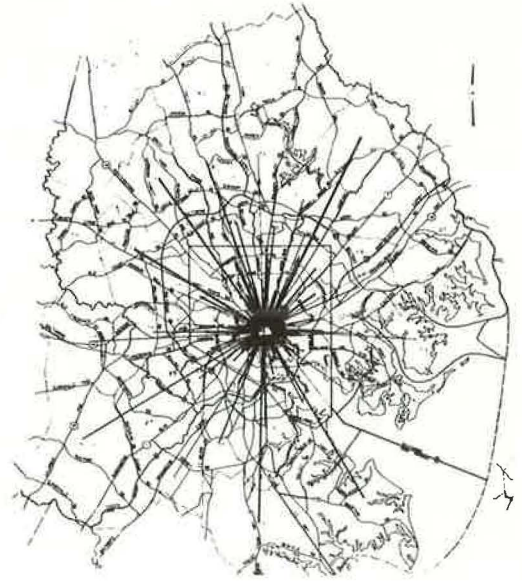

**Figure 3. Measured and projected transportation data.**

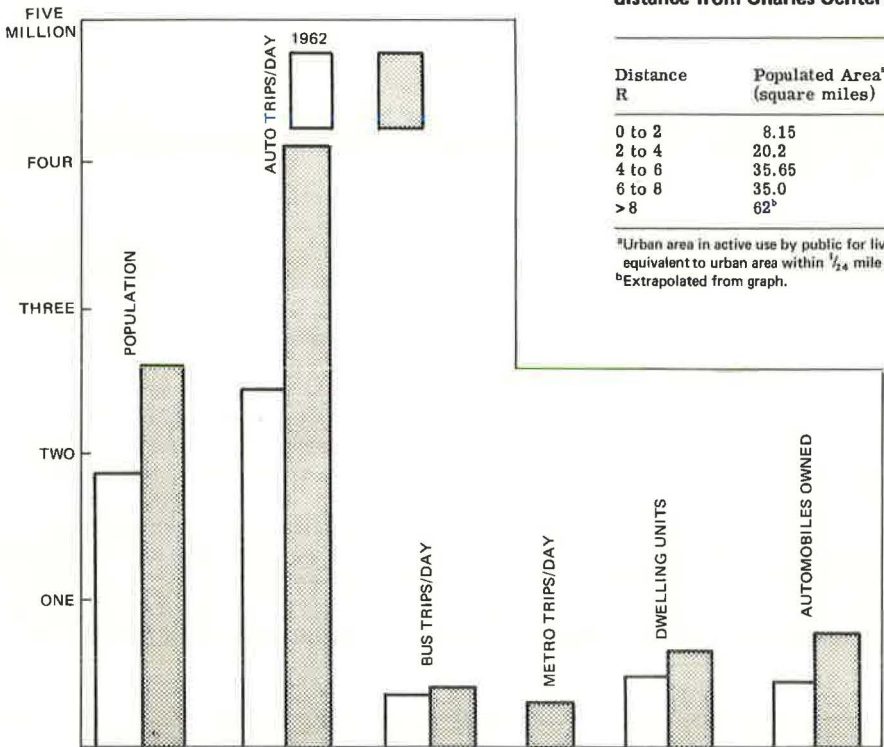

**Table 1. Distribution of populated area by distance from Charles Center.**

Distance R	Populated Area <sup>a</sup> (square miles)	Cumulative Populated Area (square miles)
0 to 2	8.15	8.15
2 to 4	20.2	28.35
4 to 6	35.65	64.0
6 to 8	35.0	99.0
> 8	62 <sup>b</sup>	161 <sup>b</sup>

<sup>a</sup>Urban area in active use by public for living and commerce; roughly equivalent to urban area within 1/4 mile of a public road.  
<sup>b</sup>Extrapolated from graph.



typically 10 percent of the daily number of trips. The number of vehicles,  $N_p$ , required during the peak hour to carry the load generated by a zone of high trip density is

$$N_p = T_1 A_1 / 10n = 60c / \Delta t_{p1} \quad (2)$$

where

$T_1$  = the total trips/day/square mile in zone  $i$ ,

$A_1$  = area of zone  $i$  in square miles,

$n$  = average number of passengers/vehicle entering (or leaving) zone  $i$  during peak hour,

$\Delta t_{p1}$  = time interval between vehicles in minutes, and

$c$  = number of routes entering zone  $i$ .

If  $\Delta t_{p1}$  is less than  $\Delta t_h$ , vehicles in addition to the number calculated in Eq. 1 will be required.

### COST AND APPLICABILITY OF HIGH-QUALITY TRANSPORTATION

The criteria defined above may now be used to estimate the costs and applicability of potential systems that would provide high-quality public transportation. Three types of public systems will be considered and compared with the automobile-based system: (a) high-service bus network; (b) simple fixed-schedule automatic system employing small, mechanically linked vehicles circulating on nonintersecting east-west and north-south loops; and (c) sophisticated system employing self-propelled vehicles capable of being routed automatically from any point in the grid to any other without transfers or stops (this type of system is often called personal rapid transit).

Comprehensive data compiled in the analysis of the transportation needs of the city of Baltimore will be used in a specific example (1). However, the general results will be applicable to most large American cities. The data from the Baltimore study (1) are supplemented by information on a populated area from a detailed map of the area. The region extends to a radius of about 14 miles from the Baltimore CBD and comprises a total area of about 500 square miles. However, much of the area is undeveloped or occupied by bodies of water, parks, and facilities such as airports. Thus, the populated area that must be served by a public transportation system is much smaller than the geographical area.

Table 1 gives the populated area in Baltimore as a function of distance from the city center and shows that the total area in 1970 was about 160 square miles. On the assumption that population density remains constant in the occupied areas as a city grows, i. e., added population is accommodated by conversion of undeveloped land, the populated area may be estimated as 140 square miles in 1962 and as 200 square miles in 1980 (3).

Transportation statistics pertinent to the present study, including the measured data for 1962 and projected data for 1980, are shown in Figure 3 (1).

Cost and performance data for buses (4), for the projected Metro system (5), and for the automatic systems (6, 7) are based on data given in published reports. The costs computed are the best estimates that can be obtained with the data available. There are major differences in the manner in which costs of construction and maintenance of the guideways and supporting services have been considered. One can make fairly accurate estimates of annual costs for the automatic systems that would operate on exclusive guideways placed on existing rights-of-way. To obtain reasonably correct estimates of all annual costs for automobile-based and bus urban transportation systems has not been possible because those systems share use of streets and highways with systems that provide other essential services, e. g., delivery of goods, mail, and fire protection, so that even if one compiles the costs of street and highway construction and maintenance, lighting, traffic signals and policemen, and street signs there is no agreement on what portion of the total should be allocated to the urban transportation system or on the extent to which these costs are borne, by automobile user taxes. Although the costs of construction and maintenance of streets and highways and their

essential supporting services are by no means negligible, they have not been considered here for the same reasons.

In view of this, cost estimates for the automobile-based system will be lower than the real costs, which may be much higher than any of us realize, but they do represent what most people consider to be the cost of driving their own automobiles. The road-related costs for high service buses would be less than those for moving an equivalent number of passengers by private automobile.

### AUTOMOBILE-BASED TRANSPORTATION COST

In common with plans of other cities, Baltimore's present plans call for meeting future transportation needs by the predominant use of automobiles. The planned public systems are designed to offer minimal service to people without access to an automobile and to offer rapid transit along some high density corridors. It is expected that additional freeways will be built as needed to enable the city to handle future automobile traffic.

The total direct cost to the community of accommodating its urban transportation needs in this way may be computed from travel statistics (1). Data on automobile operating costs have been compiled by the Federal Highway Administration (8). The direct costs of automobile fuel and maintenance totaled 7 cents/mile in 1970. Insurance and depreciation added an additional 5 cents/mile, based on an average yearly driving of 10,000 miles. The latter cost is properly associated with automobile ownership rather than operation and consequently is not included in our estimate of transportation operating costs. Based on the reported number of automobile trips shown in Figure 3, an average automobile occupancy of 1.5 persons per trip, and an average trip of 6 miles, the annual cost (in 1970 dollars) was \$213 million for automobile-based transportation in 1962. The cost of the 1962 bus operation was \$24 million (4). Thus, the total cost to Baltimore citizens of meeting their transportation needs within the city in 1962 was \$237 million. On the same basis, the projected costs to meet the predicted 1980 transportation needs shown in Figure 3 are \$365 million/year for automobiles and \$30 million/year for bus transportation; \$10 million/year, neglecting amortization, is estimated for the Metro planned to be in operation in 1980. Thus, the total cost is estimated to be \$405 million/year.

On the assumption that all present automobiles were purchased in 1962 or will be replaced by 1980 at the 1970 average cost quoted by FHA of \$3,185 each, the capital expenditure necessary to meet Baltimore transportation needs in 1962 was about \$1.5 billion for automobiles and \$31.5 million for buses. In 1980, the capital costs will be \$2.4 billion for automobiles, \$545 million for the planned Metro system, and \$40 million for the bus system, giving a total of almost \$3.05 billion. These costs do not include costs of additional freeways, which are estimated at about \$650 million (1) but for which a major portion of the cost is expected to be borne by federal funds generated by user taxes.

### HIGH-QUALITY PUBLIC TRANSPORTATION

In assessing the financial costs to the community for public transportation that would provide the high-quality service discussed above, one must consider what fraction of the total trips will be made by public transportation (modal split). The fraction will depend on relative travel time, trip purpose, and decisions of the regional and local transportation authorities concerning allocation of resources.

A study at IIT Research Institute (9) has shown that door-to-door time is the most important factor in determining modal split, and the time spent in walking and waiting is more important than transit time. Data on the running speeds of automobiles and buses from which a comparison of door-to-door travel time may be made have been compiled by the Washington Metropolitan Area Transit Authority and are given in Table 2. The running speeds listed for the buses include time for picking up and discharging passengers. Speeds of both automobiles and buses depend strongly on distance from the CBD and on whether radial or circumferential trips are made. Because the automatic system is not influenced by ground traffic, its speed is independent of location. Average running speeds quoted for automatic systems are 16 mph for the simple automatic

system in which all stations are on line, 20 to 25 mph for operation of the simple system with off-line stations that permit express service, and 30 to 50 mph for the personal rapid transit. Metro systems designed to work with the local system and, therefore, laid out in a grid with optimum spacing of about  $2\frac{1}{2}$  miles would be capable of an average speed of 60 mph or more.

Door-to-door times for the various system options can be computed from the data given in Table 2 if the time required for walking and transfers is added. These times are shown in Figures 4, 5, and 6. Added times are estimated as follows: In a  $\frac{1}{4}$ -mile grid, average walking time at 3 mph to or from a boarding point is 2 min. For the proposed network, the average trip will require 1 transfer, except for the personal rapid transit system. Waiting time is 1 min for boarding and for transfer for buses and requires 30 sec total for the automatic systems. Finally  $2\frac{1}{2}$  min is allowed for automobile parking and walking.

Figure 5 shows that buses forced to operate in traffic of current densities would give door-to-door times about 10 min longer than those of automobiles for an average 5-mile trip. However, even the 16-mph automatic system would be superior to automobiles near the urban center and would be within 5 min of automobile times for most urban trips. There appears to be little advantage to speeds of more than 25 mph for trips even as long as  $7\frac{1}{2}$  miles (Fig. 6). The combined local and rapid transit offers advantages compared to the 25-mph system only for trips longer than  $7\frac{1}{2}$  miles. In view of the high capital cost of rapid transit systems, serious questions should be raised about widespread emphasis in urban plans for such systems.

Data shown in Figures 4, 5, and 6 give strong support for belief that the automatic system could achieve door-to-door times competitive with automobiles. If the high-quality bus service proved attractive, the resulting alleviation of traffic congestion would reduce the bus door-to-door times significantly, for speed of buses would then be limited primarily by road conditions and traffic controls. Time for passenger boarding and discharge would average about 1 min during rush hours.

Ridership of the systems can be estimated from data shown in Figure 7, which shows trip distribution as affected by trip purpose and length. Work and school trips account for about three-fifths of the total trips. High-quality public transportation would offer distinct advantages for those trips; the frustration of driving in traffic and the expense and nuisance of parking the automobile would be eliminated at no loss in trip time. Advantages of public transportation are less obvious for many of the remaining trips, which generally are short, do not involve parking difficulty, and place a premium on private use of the vehicle. However, nearly half of the population during an average weekday does not have access to an automobile, and good public transportation would greatly benefit those people. Therefore, the total number of trips in these latter trip categories might be expected to increase.

It seems reasonable to predict that two-thirds or more of all work and school trips and one-third of the other trips would be attracted to high-quality public transit if urban transportation authorities established policies to encourage use of public transit. This would give a ridership slightly above one-half of the total trips but would account for 60 percent of the total trip mileage because work trips are longer on the average than other trips. Because the average family would still want to have an automobile and current ownership is only slightly above 1 car/family, no appreciable change in the number of automobiles owned would be expected.

In the United States there are no public transportation systems that offer door-to-door travel time equal to automobiles for the average trip; therefore, there are no analyses based on transportation data from which an accurate estimate of modal split may be made for the systems discussed above. Public transportation carries more than half of the trips in the central areas of New York, London, Paris, and other major foreign cities, but it may be argued that a free choice of the automobile as an alternative is not available in those cases. Modal-split analyses based on surveys of current transportation usage (9) show that trip time is the major factor, but extrapolation from 10 percent ridership to 50 percent from the equations derived by multiple regression analysis would clearly not be valid.

**Table 2. Running speed during peak hour.**

Distance From CBD (miles)	Average Speed Including Stops (mph)		Average Min/Mile	
	Bus	Automobile	Automobile	Bus
0	10.2 <sup>a</sup>	11.5 <sup>a</sup>	5.22	5.86
2½	12.0	15.7	3.82	5.00
5	14.3	19.0	3.16	4.20
7½	16.1	23.0	2.56	3.73

<sup>a</sup>Extrapolated intercept.

**Figure 4. Door-to-door time for 2.5-mile trip.**

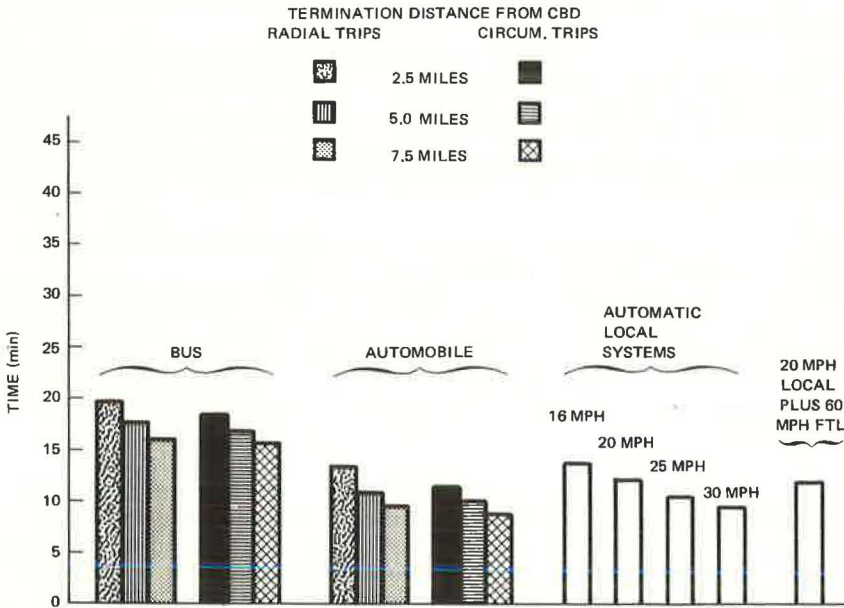

**Figure 5. Door-to-door time for 5.0-mile trip.**

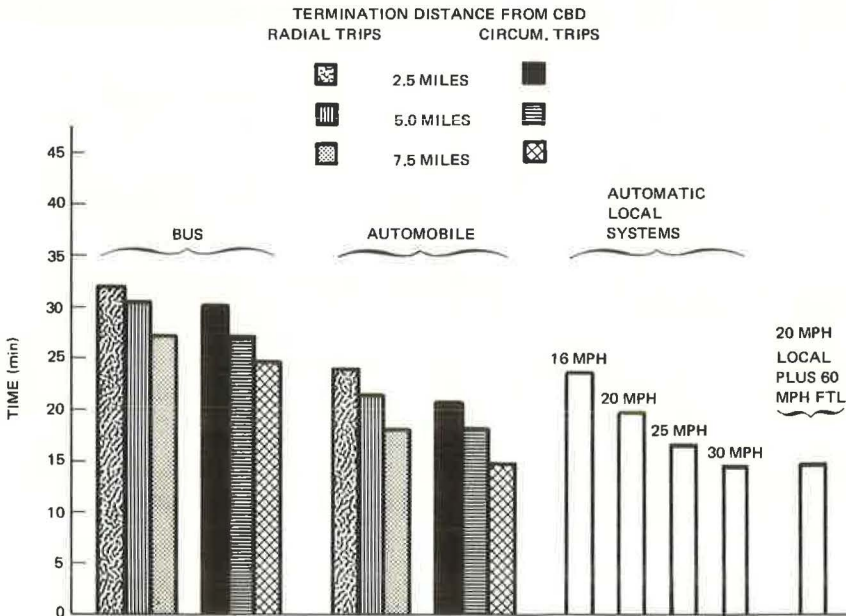

Figure 6. Door-to-door time for 7.5-mile trip.

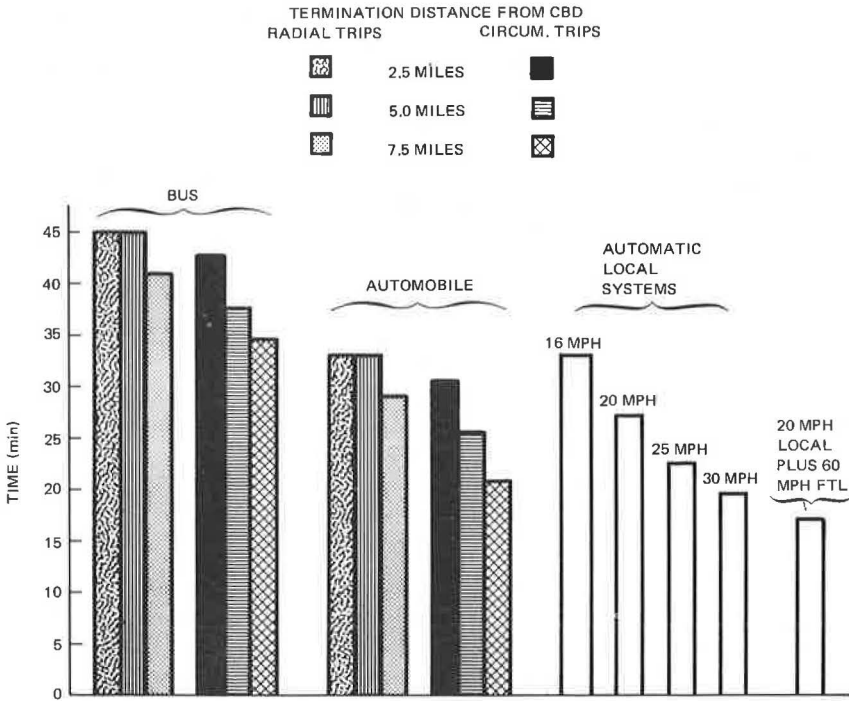
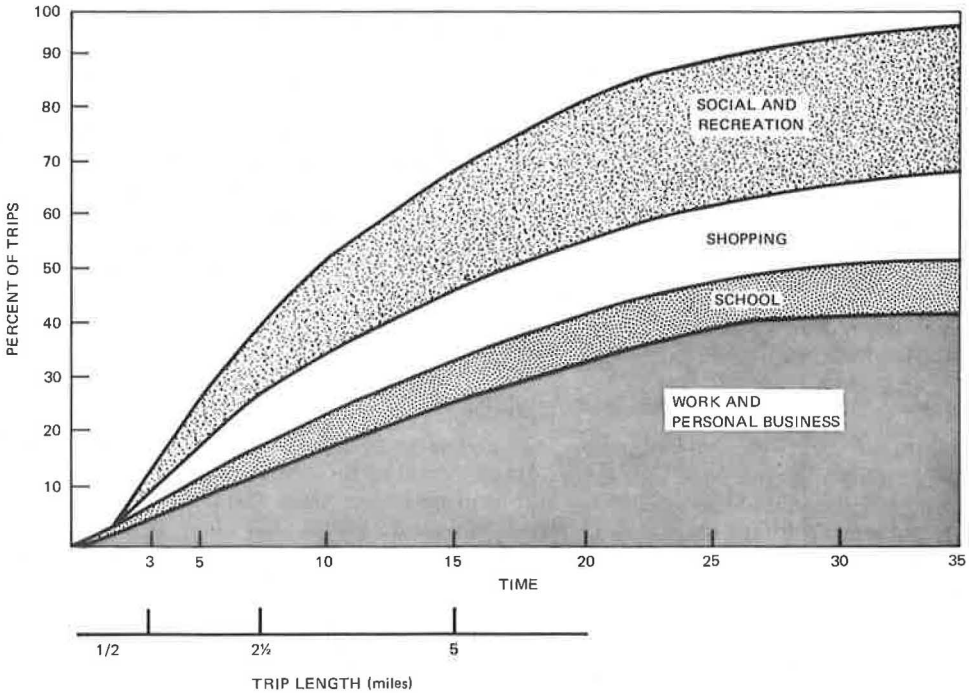

Figure 7. Percentage of trips by purpose and length.





### HIGH-SERVICE BUS SYSTEM COST

Buses in current urban use operate at average running speeds of 3 to 5 mph less than automobiles. In initial operation of the high-service system, the buses would be limited to those speeds. However if the high-quality system were popular, automobile traffic would be greatly reduced. (For Baltimore, 3,200 buses would replace 41,000 automobiles and reduce the peak number of automobiles on the streets from 61,500 to 20,500.) Speeds equal to or better than automobile speeds attainable in current traffic would be possible if adequate priority were given to buses. Traffic signal control has been effective in improving bus speeds (10). It appears reasonable, therefore, for the present study to assume a uniform bus speed of 15 mph except for the central square mile of the city where a speed of 10 mph is used. With this assumption, the number of buses that would have been required for 2-min service throughout the 140 square mile area of Baltimore in 1962 is 2,248. The populated area of this region is expected to increase 43 percent by 1980 to 200 square miles, so that the number of buses required to provide 2-min service at that time would be 3,200.

There were 215,000 trips per day made to the CBD in 1962 (1). For an average work trip of 6 miles terminating in the CBD, which is approximately 1 mile square, the average bus speed would be 14.5 mph. We will also assume that on the average a bus entering the CBD during the peak hour carries 45 passengers. The Baltimore CBD is accessible on only 3 sides; hence, only 6 lines of the  $\frac{1}{4}$ -mile, 1-way grid network would enter the CBD, and total hourly capacity at 2-min headway would be 8,100. Therefore, to carry two-thirds of the rush-hour traffic, i.e., 15,000 trips/hour, each line would require buses at a time interval of 1.08 min. Alternatively, additional routes could be provided, e.g., 6 additional 2-way routes 6 miles long to accommodate the average work trip. Either alternative would raise the total number of buses needed in 1962 to 2,320. Selection of the second alternative would increase the total route mileage at 2-min separation to 1,160 miles. Because no increase in the center population is expected in 1980, no additional buses would be needed to carry rush-hour traffic to the CBD. Thus, the total number of buses required at that date would be 3,280.

The annual cost in 1962 of operating this bus system 140 hours per week with a 2-min headway throughout the area would be \$255 million/year based on 1970 Baltimore bus operating costs of \$1/mile. The corresponding cost in 1980 would be \$360 million/year. The capital cost to purchase 2,500 (includes spares) new air-conditioned buses to meet the 1962 condition would be \$113 million. To provide complete area coverage with 3,500 buses in 1980 would cost \$145 million.

If the bus system succeeded in attracting half of the total trips, the automobile costs found in the previous section would be reduced by an amount equal to the direct cost of the automobile trips transferred to the bus. This would represent 60 percent of the automobile mileage; therefore, the remaining automobile costs would be 40 percent  $\times$  213 = \$85 million for 1962, and \$146 million for 1980. Thus, the total cost of the high-service bus option would be \$340 million for 1962. In 1980 it is expected that a Metro system will also be in operation at an annual cost of approximately \$10 million/year. Therefore, the total annual operating cost of the high-service bus option in 1980 would be \$516 million/year.

### FIXED-SCHEDULE AUTOMATIC SYSTEM

The simplest and least expensive type of automatic system that has been proposed for urban use employs mechanically linked passive vehicles that move around closed non-intersecting but overlapping loops to form a grid network. Cost and performance data have been presented for such a system (6). The system employs 2- to 4-passenger vehicles that maintain an average line speed of 16 to 25 mph and are spaced 5 sec apart to give capacity to carry the total peak load. Additional lines would be added to carry the peak load in the CBD. For the route mileage and capacity found necessary for Baltimore in the previous section, the annual operating expense of an installation to meet the 1962 traffic needs is estimated at \$105,000/mile or \$123 million/year. This includes depreciation at  $2\frac{1}{2}$  percent/year and amortization at  $7\frac{1}{2}$  percent/year of the capital cost of \$580 million, which is based on free use of the right-of-way. For an installation to

meet the transportation needs in 1980 the annual cost would be \$173 million/year and the capital cost would be \$822 million. Including automobile costs and Metro costs as explained in the previous section, total annual transportation costs for urban travel would be \$208 million for 1962 and \$329 million for 1980.

#### DEMAND-ACTUATED AUTOMATIC SYSTEM

The most flexible type of proposed automatic system employs self-propelled automatically controlled vehicles operating on an interconnected network. A number of systems of this type were analyzed in a recent study by the Applied Physics Laboratory in which performance characteristics and cost estimates were provided (6, 7). For a  $\frac{1}{4}$ -mile grid, the route mileage and system capacity needed to handle the 1962 Baltimore traffic would entail estimated annual costs (6) of \$270,000/mile or a total of \$378 million/year, which includes  $7\frac{1}{2}$  percent amortization and  $2\frac{1}{2}$  percent depreciation of the installation cost of \$2.8 billion, but assumes free use of the public right-of-way. The annual cost and installation cost to meet the 1980 needs would be \$686 million/year and \$4.0 billion. Thus, total transportation costs including automobiles and Metro would be \$464 million for 1962 and \$842 million for 1980.

#### COST COMPARISON

The costs of the 4 systems discussed above are given in Table 3 and shown in Figure 8.

The impracticability of providing high-quality bus service on a continuing basis is clear because the added community costs compared to continued dependence on automobiles would amount to more than \$100 million/year. On the other hand, the simple fixed-schedule automatic system would offer a saving of nearly \$50 million/year in 1980 total transportation costs. The automatic personal transit would be excessively expensive to operate unless financing charges for capital investment could be neglected.

#### IMPLEMENTATION OF HIGH-QUALITY PUBLIC TRANSPORTATION

An impasse currently exists in attempts to demonstrate the value of the new automatic transportation systems for urban use because neither city officials nor the federal government is willing to risk the large capital costs for installation of area-wide systems without firm assurance that public ridership will be large enough to make the system an economically sound investment. On the other hand, limited demonstrations designed to test urban acceptance are bound to fail because installation of a few miles of line can offer useful transportation only to the small number of people whose trips originate and terminate within a few blocks of such a demonstration line. (Prototype demonstrations on a small scale are, of course, necessary to prove the technical operation of the system, to demonstrate safety and public acceptability, to indicate the environmental impact, and to provide firm data on operating and installation costs.) A way to avoid this impasse is suggested by the results of the previous section. Improvement of bus systems is a high priority program of the U. S. Department of Transportation, and funds are planned for the next few fiscal years that could support the purchase of enough buses to establish a high-quality bus system covering the inner 100 square miles of a typical city such as Baltimore. With a 5 cent/mile fare, public use of the system for 40 percent of more of the total trip mileage appears possible in view of the door-to-door time comparison discussed in the previous section and especially if predicted restrictions on urban traffic become a reality. To demonstrate such public acceptance will require a subsidy of about \$100 million to support a 1-year test; \$30 million of this would represent public savings in automobile expense, which could reasonably be paid with local taxes and would constitute the major part of the local contribution to a federal grant. If the high-quality bus service proved attractive to the public, the superior service of the automatic systems would unquestionably be even more attractive. It would then be possible for cities to finance installation of the simple automatic systems with revenue bonds because profitable operation with a 5 cent/mile fare would be ensured. Furthermore installation could proceed on a line-by-line basis, with every step in the process resulting in better service and more profitable operation.

**Table 3. Transportation operating and capital costs (in millions of dollars).**

System	Automobile-Based		High-Service Bus		Automatic Fixed-Schedule		Automatic Demand-Actuated	
	1962	1980	1962	1980	1962	1980	1962	1980
Automobile	213	365	85	146	85	146	85	146
Bus	24	30	255	360				
Metro		10		10		10		10
Automatic transit					123	173	378	686
<b>Total</b>	<b>237</b>	<b>405</b>	<b>340</b>	<b>516</b>	<b>208</b>	<b>329</b>	<b>464</b>	<b>842</b>

Note: Costs include amortization at 7% percent per year and depreciation at 2% percent per year on capital investments of high-service bus and automatic systems. Amortization of automobile costs is not included on the assumption that only automobile use and not automobile ownership will be affected by the availability of high-quality public transportation. Amortization of Metro costs is omitted because that will depend on policy with regard to federal contributions. In any case, these costs would add the same amount to all 4 alternatives.

**Figure 8. Annual 1980 costs for transportation alternatives (amortization costs included for automatic systems).**

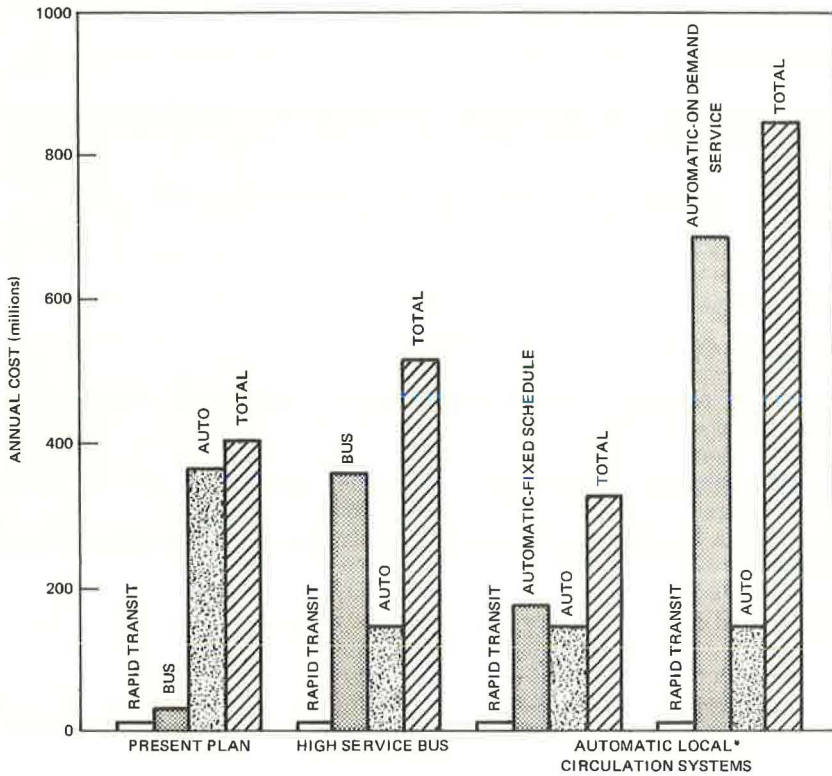

NOTES: LINE AND STATION SPACING ARE ¼ MILE THROUGHOUT THE AREA WHERE SERVICE IS PROVIDED 20 HRS/DAY. HIGH SERVICE BUS OFFERS 2 MIN. HEADWAY; AUTOMATIC SYSTEMS OFFER 15 SEC. HEADWAY.



## CONCLUSION

The foregoing discussion shows that public transportation can offer travel times competitive with the automobile provided that the system features area-wide service with closely spaced boarding points and short headways. It is suggested that such a system, if it were competitive in cost to the traveler, could lure a substantial fraction of the urban trips away from the present and projected overwhelming use of the automobile. Bus systems designed to provide high-quality service are shown to require a transportation cost to the community much higher than that which would result from predominant use of automobiles for transportation. Therefore, bus systems do not appear to offer a feasible alternative to automobiles for urban transportation without heavy subsidy. However, the simplest automatic systems, because they minimize labor costs, could save a community the size of Baltimore nearly \$50 million/year compared to automobile-based urban transportation. Implementation of such automatic systems requires demonstration of their public acceptance, and this can be done only with large capital expenditure. It is suggested that a feasible method to eliminate risk would be to judge public acceptance of good transportation by installing high-quality bus service in a typical city under federal support. After public acceptance was shown, the city could proceed with the automatic system, assured that it would be preferred to automobiles and would be self-supporting with a low fare.

## ACKNOWLEDGMENT

I wish to express my thanks to Robert C. Rand and Gertrude S. McMurray for helpful discussions and assistance in preparing this paper.

## REFERENCES

1. Baltimore Metropolitan Area Transportation Study Findings and Recommendations. Wilbur Smith and Associates, Vol. 1, 1964.
2. Anderson, J. E. Morphology of Urban Transportation. ASCE, Preprint 1468.
3. Rand, R. C. Fiscal Policy for Urban Transportation. First National Conf. on Personal Rapid Transit, Univ. of Minnesota, Nov. 1971.
4. Statistics 1971. Metropolitan Transit Authority of Maryland, Baltimore.
5. Capital Cost Analysis. Washington Metropolitan Area Transit Authority, Tech. Rept. 2, Oct. 1967; National Technical Information Service, Springfield, Va., PB 177 054.
6. Avery, W. H., Makofski, R. A., and Rand, R. C. Advanced Urban Transportation Systems: An Overview. Transportation Research Institute, Carnegie-Mellon Univ. Rept. 5, 1971.
7. Ford, B. M., Roesler, W. J., Waddell, M. C. Parametric Analysis of Generic Urban Transit Systems. Applied Physics Laboratory, Johns Hopkins Univ., TPR-001, Dec. 1969; National Technical Information Service, Springfield, Va., PB 188 984.
8. Cost of Operating an Automobile. Federal Highway Administration, U.S. Department of Transportation, 1970.
9. Bock, F. C. Factors Influencing Modal Trip Assignment. NCHRP Rept. 57, 1968.
10. A Bus Priority System for Traffic Signals. Kent State Univ., UMTA Proj. Ohio MTD-4, 1971.

## DISCUSSION

William H. T. Holden, Daniel, Mann, Johnson and Mendenhall, Los Angeles

This paper is of unusual interest in that it shows the high capital and operating costs of those systems described as personal rapid transit. However, it assumes use of only 1 mode, aside from the walk to the station. But the fact is that modern rapid transit systems assume that passengers do not walk to the station but drive there in their automobiles or are driven by some member of the family. Feeder-bus service

may also be used where population density will support such lines. Walking access, at 20 min/mile, is limited to a distance of about  $\frac{1}{2}$  mile; feeder-bus access at 6 min/mile can be used for distances of a few miles, while automobile access at 2.5 min/mile can expand the service area of a station from the 1 square mile of walking access to as much as 16 to 25 square miles making the feasibility of rapid transit a function of total population and not of population density.

In some of the paper, and in the data quoted from Wilbur Smith and Associates, use is made of the questionable person-trip unit. Figure 7 can be converted into a form that provides a significant measure of the amount of transportation furnished by various modes—the passenger-mile.

Reference is made to a high-service bus system. It is apparently assumed that bus operating costs are not dependent on operating speed, which is about 10 percent lower than scheduled speed because of terminal layover times of 10 percent of the time in motion. It was found by the writer, from data in the NYCTA Transit Record, that bus operating costs in that area are given by

$$C_n = 23.22s_3 + 19.02$$

where  $C_n$  is direct operating cost in cents per bus-mile, and  $s_3$  is operating minutes per mile, which is 60 times revenue bus-hours for the period in question divided by revenue bus-miles in the same period.

It is not probable that bus schedule speed can approach automobile speeds as suggested by data given in Table 2. It is stated that each bus will carry 45 passengers, average. Loading delays are 2 to 3 sec/passenger, with exact fare systems. Somewhat lower delays are observed in Los Angeles where there is extensive use of monthly pass riding. But 45 passengers will involve a delay of the order of 2 min, and the observed operating speeds in New York are as follows:

Borough	Operating Speed (mph)	Estimated Scheduled Speed (mph)
Manhattan	5.93	6.52
Queens	8.59	9.45
Staten Island	10.73	11.80
Brooklyn	7.25	8.00

For this reason, it is questioned whether the speeds mentioned by Avery are practicable or attainable. These corrections will tend to modify the conclusions as to cost of the suggested high-service bus system. It is also commented that the limitations on bus dimensions imposed by the highway codes make it impossible to design a bus that is a satisfactory transit vehicle. Considerations of the safety and comfort of passengers make it impossible to provide acceleration and braking rates that can compete with the passenger automobile except under the most extreme conditions of traffic congestion where neither one can move at a speed of more than a few miles per hour.

This paper describes proposed grid systems, with lines on close spacings, that are apparently intended to replace the automobile for most of the urban travel needs. It is pointed out that there are 3 types of urban travel: many-to-many or diffuse travel; many-to-one, as to a CBD; and one-to-one as between centers in an area. Of these, the automobile alone can provide satisfactory service in the first type. Demand is low along any of the numerous routes. Types 2 and 3 are best served by transit, with the automobile used for station access.

In CBD areas, it will be desirable to provide a secondary collector-distributor system of the automatic type, paralleled by pedestrian walkways, to reduce walking distance, reduce or eliminate surface bus operation, and reduce the number of CBD sub-way stations required.

The costs indicated by the paper are such as to render it doubtful whether the systems of the personal type can be justified in any case.

## AUTHOR'S CLOSURE

Holden's comments on transportation concepts that appear regularly in his magazine, *City and Suburban Travel*, have won him the high regard of his colleagues for his down-to-earth understanding of systems problems. His comments are, therefore, welcomed. However, in this instance he appears to have missed some points that were discussed in the paper only briefly.

With regard to his first comment, the paper does not assume use of 1 mode but rather explores the requirements and potential use of systems that could provide good service and thus be practical alternatives to the automobile-based transportation that he describes. Metro systems are included in the evaluation but not explored in detail because they carry only a minor fraction (5 to 15 percent) of the total trips—and trip-miles.

The trip-mile recommended by Holden is in fact used in the paper as a unit of travel where operating costs are compared. However, the number of trips is a more easily understood measure of urban travel by the average reader and gives a better indication of the amount of activity involved in daily transportation.

With regard to bus speeds, our data are based on average running speeds measured by the Washington Metropolitan Area Transit Authority and are given in Table 2. Bus costs computed by Holden's formula would average \$1.12/hour versus \$1.00/hour used in the paper, which is based on Baltimore operating costs. It is not expected that buses operating in automobile traffic would be able to match automobile speeds. Bus speeds would be improved if good bus service led to reduction in the number of automobiles or if priorities were given to bus travel. But the point of this comparison is to show that, if buses could be operated to match automobiles in door-to-door time, the operating cost would be so much higher than providing the same service with automobiles that the benefit to the community would be questionable.

Holden's final point is a common position but not verifiable because no grid system providing good access and frequent service has been installed anywhere in the United States since automobiles became common. The Paris public transit system provides an approximation to such area coverage and service within a radius of about 3½ miles from the CBD and in this area carries 65 percent of the total trip-mileage; beyond this radius, public transportation offers poor service, and a high proportion of automobile owners prefer to drive their cars. This could indicate that good service attracts passengers from automobiles, but road coverage and automobile ownership in Paris are not comparable with U.S. conditions. As my paper shows, a closely spaced, area-wide grid system with small automatic vehicles would appear to offer service that would attract a major fraction of routine automobile trips. The lower operating cost of such a system could provide substantial savings in community transportation expenditures compared to the expense of continued dependence on automobiles for 80 to 90 percent of the total trip mileage.



# METRO GUIDEWAY: AN INTEGRATED URBAN TRANSPORTATION SYSTEM

Eugene T. Canty, General Motors Research Laboratories, Warren, Michigan

The greatest need of future urban transportation is for improved arterial transportation facilities in larger metropolitan areas. To provide for these needs by conventional means, including additional urban freeways, expressways, arterial streets, and public rapid transit systems, will entail the expenditure of large sums of money and will create social and environmental impacts that will limit the public acceptability of the new facilities. It may be possible to reduce such economic and social costs through the development and implementation of new arterial systems. An integrated urban transportation system called the Metro Guideway is described. This would provide an automated roadway network accommodating dual-mode automobiles, personal and group rapid transit vehicles, and automated freight carriers. A brief resume is given of the current program of design, analysis, and evaluation of the Metro Guideway concept.

•THIS PAPER is intended to be a contribution to the discussion of future urban transportation needs and the potential of new system concepts including automated highways and personal rapid transit systems as solutions to those needs. Although much thought has been given to the assessment of future transportation needs [witness the considerable effort on the 1990 Transportation Needs Study that has been under way for more than a year by federal, state, and regional planners (1, 2, 3)], emphasis has been on the satisfaction of those needs by fairly conventional urban freeways and public transit. It will be argued here that new technological possibilities in urban transportation should be realistically evaluated in terms of specific anticipated needs and that national urban highway and transit planning policy should give added attention to new systems.

More specifically, this paper will discuss an integrated urban transportation system concept that is currently being investigated as a potential solution to what appear to be the most pressing urban transportation problems: the needs for improved arterial transportation facilities for public transit, for private automobile travel, and for goods movement within larger metropolitan areas. Called the Metro Guideway, the system represents a synthesis of certain previous concepts for dual-mode vehicle systems and personal rapid transit with certain new functions and capabilities. The paper describes how this system concept is being analyzed and evaluated relative to the projected needs of some 87 large urbanized areas of the United States.

[The term Metro Guideway is employed in order to avoid confusion with ambiguous terminology such as personal rapid transit and automated highways. The Metro Guideway is essentially a technological adaptation and synthesis of 4 modes of transportation previously described by Canty and others (4, 5) and is functionally similar to the technologically nonspecific concepts of NET-3 as described by Henderson and others (6), to dual-mode transit as described by Hamilton and others (7), to the integrated arterial mode described by Canty (8), and to the metropolitan guideway postulated by Doxiadis and his associates (9). ]

## ESTIMATION OF FUTURE URBAN TRANSPORTATION NEEDS

It should be appreciated that, in a forecast of urban transportation needs, an objective estimate is not possible. Transportation is not an end in itself but only a means for attaining other social and economic objectives that are more suitable to subjective evaluation rather than to absolute determination. Second, the estimates are subject

to obsolescence as new data become available; in this case, the new data are in the forthcoming report to the Congress by the U. S. Department of Transportation on the 1990 Transportation Needs Study. Nevertheless, for the purposes of this discussion, one needs to proceed on the basis of the limited data currently available.

The results of the 1968 National Highway Functional Classification Study (10, 11) provide the best measure of current patterns of automotive travel in urban areas. Data obtained from the Federal Highway Administration on 1968 vehicle travel on various urban roadways by functional classifications are shown in Figure 1. Preliminary estimates prepared by General Motors Research Laboratories on the basis of information from a number of sources indicate an overall increase in the order of 110 percent in automotive travel in urbanized areas by 1990. [Sources include projections of aggregate population and travel data for urbanized areas as provided by the Federal Highway Administration in the National Highway Functional Classification and Needs Study Manual (2).] Figure 1 shows that the largest expected increases, both relatively and absolutely, are in travel on freeways, expressways, other principal arterials, and minor arterials that constitute the urban arterial highway system.

If one further analyzes the patterns of automotive travel in terms of the characteristics of the urbanized areas in which the travel would occur, one finds that more than 85 percent of both the present and anticipated urban travel occurs in 87 urbanized areas. (The selection of urbanized areas was by criteria considered as minimal for the consideration of areas such as locales for automated roadway networks or limited-access rapid transit facilities. Although the rationale for selection will not be discussed here, the criteria include a projected minimum urbanized area size of 170 square miles and a projected minimum population of 425,000, both as of 1985.) The changes during the 1968-1990 period in those 87 areas are shown in Figure 2; Figure 2a shows vehicle-miles of travel, and Figure 2b shows additional arterial roadway facilities judged to be necessary to accommodate this higher level of traffic. The cost of the new arterial roadway facilities in the 87 areas is estimated to be in the order of \$175 billion (in constant 1970 dollars). [Estimates were made by Gustafson and Golob, General Motors Research Laboratories; however, unit costs for construction were obtained from Kasoff and Gendell (12).]

Only limited data exist on the needs for urban public transportation facilities. Indeed, one of the purposes of the National Transportation Needs Study is to inventory needs in the area of urban public transportation. In the interim, currently available information on prospects for capital investment in urban public transportation (13) may be employed as an indication of such needs (although it is acknowledged that perceived needs are not synonymous with investment plans). The estimates prepared by the Institute of Public Administration in 1969 of prospective capital investment during the 10-year period 1970-1979 are for a total of \$32.8 billion (in constant 1969 dollars and no inflation in construction costs).

Of the total \$32.8 billion, approximately 93 percent or \$30.5 billion is expected to be needed in 29 urbanized areas that will have populations of more than 1 million as of 1980. Of that \$30.5 billion, a very large proportion, or almost \$30 billion, is for capital investment in fixed facilities and rolling stock for grade-separated systems: rail rapid transit, suburban railroads, and busway-guideway systems. No investments were seen for grade-separated systems in urban areas of less than 1 million population.

On the basis of the 10-year estimate by the Institute of Public Administration, a preliminary estimate of several tens of billions of dollars for urban rapid transit needs during the next 10 decades seems reasonable. That estimate coupled with the estimated need for some \$175 billion in arterial roadway facilities (in 87 large metropolitan areas) gives a combined investment in public and private arterial transportation facilities in the 87 selected urbanized areas of approximately \$250 billion. This, then, is the total "market" for urban arterial facilities in large metropolitan areas during the next 2 decades; some portion of that market may be suitable to the application of new system technology.

A public decision to expend an amount of money of this magnitude must be considered in light of other urgent national priorities. However, discussion of such relative priorities is beyond the scope of this paper. A more germane consideration is that, when such a

**Figure 1. Daily vehicle-miles of travel on urban roadways by functional classification.**

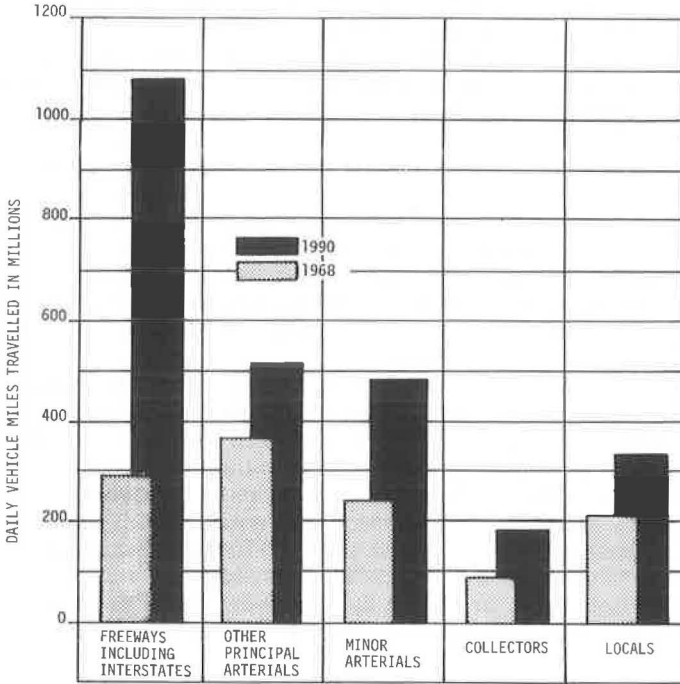

**Figure 2. Changes in vehicle-miles of travel and route miles in 87 urbanized areas.**

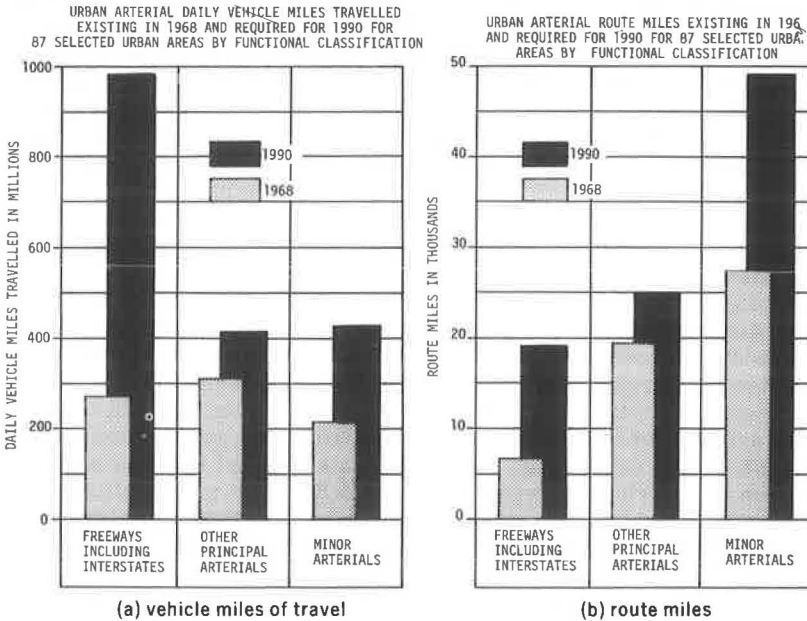

large investment is being considered, even a marginal improvement in system effectiveness, or a reduction of 1 or 2 percent in cost, can yield great benefits, measurable in billions of dollars. As a result, room exists for a serious and substantial program of research and development on new and improved systems of highway transportation and public transit. It is conceivable that a large research and development effort, totaling as much as several hundreds of millions of dollars, could be mounted in the expectation that a still greater level of benefit can be realized.

For a program of such magnitude, which has no real precedent in civil affairs, it is appropriate to reevaluate previous preconceptions as to what level of investment in research and development of new urban transportation systems may be considered as reasonable or as too expensive. Putting it another way, the program of construction of post-Interstate highways and public transit facilities in urban areas may become the greatest civil project in any nation's history, comparable in magnitude only to wartime military projects. Under such circumstances, it would be premature to categorize automated highway, personal rapid transit, or other new concepts as being too futuristic or as requiring excessive research and development before a more thorough evaluation is made of the costs and benefits of such new systems in light of national needs.

#### COMMENTS ON RELIANCE ON CONVENTIONAL FREEWAYS AND PUBLIC TRANSIT

In plans for meeting future urban transportation needs, primary consideration is usually given to the construction or extension of facilities for present modes of transportation, including conventional roadway networks and public transit. For arterial travel in large metropolitan areas, the relevant facilities are urban freeways and limited-access public transit (for rail transit or bus rapid transit). However, such facilities are limited in their acceptability.

The major barriers to acceptance of urban freeways are the perceived negative social, environmental, and economic impacts of those freeways on the communities through which they pass. The major design characteristic of urban freeways leading to such negative impacts is the significant land requirement. Land required for right-of-way, buffer zones, interchanges, and entry and exit facilities causes families to be displaced, neighborhoods disrupted, public buildings destroyed, park areas appropriated, and real estate removed from the tax rolls. These effects have already resulted in a number of citizen actions against the construction of urban freeways (14). To some extent, such opposition has been based on specific freeway design or location rather than the need for the freeway itself, but the lack of a consensus on design or location may have the same effect as opposition to the freeway per se (15). Such opposition will become more severe in the future as more urban freeways are proposed and as the methodology of protest becomes further developed. Consequently, the extent of construction of urban freeways may be considerably below that which is considered to be warranted on the basis of conventional user-related cost-benefit analyses.

In previous years, when the main warrant for highway construction was that user benefits outweigh right-of-way acquisition and construction costs, there was, in effect, a simple ceiling on congestion effects. Whenever travel time or accident rates became excessive, new facilities would be built (although administrative, planning, and construction delays might prolong the unacceptable conditions). However, as one considers various social and environmental impacts of roadway construction and internalizes these into the cost estimation process, one in effect raises the ceiling on user costs that are tolerable before new facilities are constructed. Consequently, the relief of nonuser social and environmental impacts of freeway construction must necessarily result in an increase in the expected value of user costs (e.g., travel time) as long as continued reliance is placed on conventional technology for highway transportation.

The situation regarding public transit is rather different. Whereas the major problem with urban freeways has been acceptability in regard to social and environmental factors, the major problem with transit has been its lack of attractiveness to users. In view of the prevailing and projected land use patterns in most of the metropolitan areas of the United States, most trips are, and increasingly will be, of a diverse pattern with regard to location of trip origins and destinations (16). Such a travel pattern



is ill-suited to conventional public transit (17). This is reflected in a low level of transit ridership that tends to keep such systems from being economically self-supporting. Also, because such systems are patronized by a usually small percentage of the total population, obtaining necessary financial subsidies is dependent on the development of a conviction by the general public as to the value of social and environmental benefits of such public transit facilities, chiefly improved mobility for the disadvantaged or the negation of environmental impacts of proposed freeways, and on the evolution of institutional processes for decision-making in respect to urban public transportation (18).

Because of these largely subjective factors, it would be difficult to forecast the extent to which additional public transit facilities of conventional design will be built. However, in any event, because the expected patterns of travel demand are so mismatched with the service capabilities of public transit, it does not appear likely that more than a small fraction of total trips in most metropolitan areas can be served by public transit. As a result, it must be anticipated that most of the increase in urban area travel must be accomplished by automotive vehicles over an expanded highway network or by new systems of private and public transportation rather than by conventional public transit (17, 7).

The major effect of a continued reliance on conventional means of urban transportation would appear to be an increase in the total socioeconomic cost of transportation to the community. This increased socioeconomic cost comprises both the social and the environmental impact on local communities of urban freeways that are constructed and the increases in congestion-related user costs, such as travel time and accident exposure, in those areas where freeway construction is prevented because of its potential nonuser impact.

#### PRIMARY OBJECTIVES OF NEW URBAN TRANSPORTATION SYSTEMS

To provide an exhaustive list of objectives for new systems of urban transportation would be difficult if not impossible inasmuch as planners consider transportation to be a useful tool to achieve certain community sociological, economic, and physical planning goals as well as to directly satisfy transportation requirements. However, in light of the foregoing discussion of future urban transportation needs, a few primary objectives may be listed:

1. The cost of providing a given level of highway capacity or rapid transit performance should be reduced;
2. The social and environmental impacts of urban roadway facilities should be improved;
3. The user-related attributes of automobile-highway systems should be improved, particularly with regard to travel time and safety;
4. The user-related attributes of public transportation should be improved so that transit more nearly corresponds with automotive transportation and is available to all groups within the population at acceptable cost;
5. Better means of public transportation should be provided for all types of travel within metropolitan areas;
6. Technology should be made available that would make it possible for a community to establish for all members of that community a minimum mobility level, such as being able to travel almost door to door by public transit anywhere within the metropolitan area; and
7. Because of the great economic importance and environmental influence of goods movement within metropolitan areas, provisions should be included for more efficient movement of freight.

#### SUGGESTED APPROACHES TO A SOLUTION

It may be possible to achieve the previously outlined objectives by an approach to the design of a new system that embraces these design principles: Certain roadway facilities



and vehicles should be automated; common roadway facilities should be employed for automobiles, public transit, and freight movement; and these facilities should be integrated into the urban environment by the utilization of techniques of joint development and multiple use.

There are several reasons for automation of roadways and vehicles:

1. Through automation, one intends to achieve greater roadway capacity as measured in vehicles per lane per hour. As a result of this greater capacity, fewer lane-miles of roadway are required to accommodate a given volume of traffic. Thus, fewer additional lanes need to be built in the future, less land needs to be taken for rights-of-way, fewer families need to be displaced, and so on. In some instances, one should be able to make more intensive use of existing rights-of-way and thus lessen additional land acquisition.

2. If the increase in roadway capacity is proportionally greater than the increase in cost due to automation, as one would intend, a cost reduction per unit of roadway capacity is achieved.

3. Automation enables a more stable flow of vehicles at higher operating speeds for a given separation distance. This benefits automobile users through a reduction in travel time and a decreased likelihood of accidents.

4. Automation of transit vehicles enables driverless operation within the confines of the automated network. This enables a saving in driver labor and a consequent reduction in transit operating costs. It also enables one to employ a multiplicity of small vehicles that have improved amenities over current public transit vehicles, that may be routed more directly between origins and destinations, and that do not require passengers to possess driving abilities.

5. Some freight movements should be automated, primarily for economic reasons. Automation would eliminate driver labor for certain types of unmanned freight carriers and reduce driver labor through the reduction in travel time for other types of freight movement where the driver remains aboard.

The reasons for integration of automobile, transit, and freight vehicles include the following:

1. Through economies of scale and elimination of duplications, the financial cost and the social and environmental impacts of construction of a combined facility would be less than the total of those for separate facilities;

2. A community can have a more extensive network of transit facilities than would be economically possible if separate transit facilities were employed;

3. Opportunities are created for flexibility in roadway pricing policy (for example, revenue from sources such as taxes or tolls on automobiles and freight vehicles may be utilized to financially support transit operations);

4. It is desirable, for reasons of social justice and for achievement of a consensus of community support, that new systems offer as much equality as possible in modal performance through the utilization of common facilities.

The principles of joint development and multiple use of transportation rights-of-way with other urban functions have been discussed by others (20) in the context of existing modes of transportation. The advantages of joint development and multiple use are especially applicable to new systems that are automated and that employ common facilities for automobiles, transit, and freight movement.

#### THE METRO GUIDEWAY SYSTEM CONCEPT

The approaches outlined above, principally those of vehicle-roadway automation and integration of modes, and, to a lesser extent, joint development and multiple use, lead to the Metro Guideway system concept. The Metro Guideway system would provide for the modes of urban transportation discussed below (Fig. 3).

#### Dual-Mode Automobile Transportation

Privately owned vehicles would be operated on both ordinary roadways and new facilities as directly as possible between origins and destinations; because the new facilities

would be automated, dual-mode vehicle designs are required. The convenience and amenities of present automobiles are carried over to this new mode. The intended benefits of the new system to automobile users include reduced travel time, improved reliability of travel time, and improved safety. The intended benefits of dual-mode automobile transportation also include those resulting from more efficient use of rights-of-way, that is, minimization of the negative social and environmental effects of urban freeway construction.

### Public Transportation Modes

Personal Rapid Transit—Personal rapid transit involves personalized small vehicles (accommodating 4 to 6 passengers) that would be publicly available at stations and automatically controlled over special roadway facilities within the system network. [In this sense, personal rapid transit corresponds to the generic category of systems labeled NET-2 by Stanford Research Institute (6); the demonstration system under construction at Morgantown, West Virginia (21) does not fall into this category because the system does not provide the personalized accommodations, the direct service, and the speed required for personal rapid transit throughout a metropolitan area.] The intended benefits of this mode derive from the following considerations:

1. The personal public transportation vehicles are sized to provide accommodations for individuals and families or other affined groups and thus extend the privacy and security amenities of automobiles to public transportation;
2. Because the vehicles are small and private, they may be routed directly from an origin station to a destination station without requiring intermediate stops or transfers, thus providing some of the convenience features of private automobiles, as well as higher average speed;
3. Because the vehicles are publicly available at stations within the network, the personal transportation amenities and convenience of this mode are made available to those who are not able to or who choose not to purchase private automotive vehicles; and
4. Because the vehicles are automated, the amenities and convenience of this mode are made available to those who are not able to or who are not trained to or who prefer not to drive automobiles.

Single-Mode Group Rapid Transit—This mode of public transit differs from personal rapid transit in that the group rapid transit vehicles are larger (accommodating 12 seated passengers) and, with the aid of computer routing and scheduling, make multiple stops at off-line stations on the automated roadway to pick up and discharge passengers while other passengers remain on board. [This transportation function corresponds to that which the Morgantown system (21) would provide when its vehicles are operated in single units under demand-responsive control.] When vehicles are shared, operational efficiency is improved and costs are reduced relative to those of personal rapid transit, but some sacrifice in privacy, convenience, and travel time results. In this sense, relation of this mode to the personal rapid transit mode would be analogous to the relation between demand-responsive jitney service (23, pp. 14-39) and conventional taxi service on ordinary streets.

Dual-Mode Group Rapid Transit—Group rapid transit can also be provided by dual-mode, jitney-sized vehicles that are operated on ordinary streets and roadways by professional drivers and on the automated network by automatic controls. Operation off the automated network corresponds to demand-responsive jitney or dial-a-bus service described elsewhere (4, Pt. G; 22; 23). Operation on the automated network is outlined in the preceding section. Algorithms and computer programs developed for allocation and routing of D-J vehicles on ordinary roadways are applicable to dual-mode group rapid transit including travel on both ordinary roadways and the automated network.

Dual-mode group rapid transit would enable high standards of mobility and accessibility to be established for urban public transit. Door-to-door public transportation with minimal transfer requirements would be possible throughout a metropolitan area, and reverse commuting needs could be readily accommodated.

**Fixed-Route Transit Via Captive Vehicles**—This mode of public transit is by larger vehicles, which may be coupled in trains, and provides fixed-route, frequent service along main lines of the automated network. [ This service is similar to that provided by rail rapid transit, intended to be provided by the Westinghouse Sky Bus (24), and demonstrated by new systems such as the one at Morgantown, West Virginia, when operated under fixed-route, fixed-schedule control.]

**Dual-Mode Bus Rapid Transit**—This form of public transportation has been described (4, Pt. F) but does not currently exist in operational form. Motor coaches (accommodating 24 passengers) would be operated on ordinary roadways by drivers and on automated roadways by automatic control (with or without the driver being on board). Typical operation on the automated roadway would include express service, i.e., nonstop or with a small number of stops for access to major activity centers, and local service on the guideway within such activity centers for collection and distribution functions. The advantages of this mode include the following:

1. Relative to competing modal concepts such as rail rapid transit, bus rapid transit offers the potential advantage of elimination of the transfer requirements between the feeder mode and the rail transit mode and a resultant saving in transfer time and effort;
2. Relative to rail rapid transit, bus rapid transit offers the advantage of reduced travel time through express service (rail rapid transit trains must usually stop at many stations on the trunk line);
3. Relative to present forms of bus rapid transit, the dual-mode version would be more economical in that driver control would not be required (if the driver remained on board, he could devote his attention to other matters such as fare collection); and
4. Automatic control while on the guideway should result in less travel time, less variation in travel time, smoother operation, improved comfort, and greater passenger safety.

#### Freight Transportation Modes

**Dual-Mode Freight Vehicles**—The automated roadway would be designed to accommodate dual-mode trucks and vans (up to a maximum size or weight to be determined). The truck drivers would remain on board to resume vehicle control upon exit from the guideway. Economic savings would result from increased speed and the reduced amount of operator labor in the transport of goods.

**Captive Freight Service**—This mode of transportation provides for unattended movement of various types of freight among freight terminals adjacent to the automated roadway. In comparison with the dual-mode freight operation, the captive freight vehicle operation enables the saving of the total vehicle operator's wage in certain shipping operations. Examples of automated freight operations include shipment of mail among post offices and to and from airports; shipment of parcels from central warehouses to outlying points where they may be transferred to road vans; and shipment of solid wastes from local collection points to compacting facilities prior to rail shipment to disposal sites.

#### ALTERNATIVE CONFIGURATIONS

Various configurations of the Metro Guideway are possible. The principal difference is among the configurations involving alternative design choices with regard to the following functional subsystems: roadway geometry, network access, lateral guidance, longitudinal guidance, vehicle-roadway interface, propulsion, and network routing and scheduling.

A number of candidate system configurations are being analyzed at the General Motors Research Laboratories. This work is reported separately (25). Some of the elements in these configurations have counterparts in system proposals or experimental investigations by General Motors and other research groups too numerous to acknowledge individually. The intent of this current work is to eliminate or minimize the shortcomings of previously proposed subsystem techniques where possible, to develop new subsystem concepts where necessary or desirable, and to synthesize a prac-



tical and preferred system design. In regard to the latter, an evaluation procedure is being employed that is intended to be realistic and comprehensive as to the needs and objectives of the various actor groups in representative metropolitan areas.

#### PROGRAM OF STUDY

The foregoing discussion has emphasized the great magnitude of future urban transportation facility needs and the multiplicity of impacts that new systems will have on various system users and others in the community. Because of these considerations, it is necessary to analyze and evaluate the Metro Guideway system on a multifaceted basis and to consider technical, economic, environmental, social, and political factors and practical implementation planning.

An analytical case study approach is being followed by the General Motors Research Laboratories. This involves the classification of metropolitan areas, the identification of representative metropolitan areas, the design and analysis of a number of alternative Metro Guideway and conventional system configurations for each representative area, the evaluation and choice of preferred system configurations, and the extrapolation of case study results to the total set of metropolitan areas. This overall process has required the development of a number of new analytical tools.

The selection of case study locales has involved the collection and development of an extensive data base of economic, demographic, geographic, transportation, land use, and other characteristics of all metropolitan areas of the United States. It has also required the development of a new method (26) for the stratification and clustering of metropolitan areas into groups, the members of which are homogeneous with regard to urban area characteristics and with regard to the nature of their urban transportation requirements (Fig. 4). This enables the identification of preferred case study locales on the basis of statistical representativeness and of subjective factors including availability of planning data.

Base-line system definition documentation is being prepared for alternative configurations of the Metro Guideway system. These include design definition to a level of detail adequate for analysis of performance and cost and for specification of the environmental characteristics of the system (including land requirements). These base-line designs are adapted to the needs of the case study metropolitan areas at a future point in time.

A case study that is currently in progress is examining the application of the Metro Guideway concept to the arterial transportation needs of the metropolitan Detroit area as it is expected to appear in 1990. This includes an extensive network of automated roadway facilities: approximately 200 route-miles of dual-lane roadways; 180 sets of entry, exit, and station facilities; and 22 major interchanges among main lines.

The performance of the automated network is being assessed relative to the forecast patterns of travel in the Detroit area in 1990 by means of a digital computer simulation that follows the individual movements of each of the large number of vehicles that are in operation over the network and in the entry and exit areas. This simulation models the configuration design, particularly the software and hardware aspects of network routing, scheduling, and control, in such a manner that the feasibility, performance, and cost of alternative designs of centralized and decentralized methods for such routing, scheduling, and control can be ascertained. The procedures for this simulation effort are described elsewhere (27).

The potential effects of vehicle, roadway, and control mechanization subsystem failures are being investigated by means of 2 approaches. On a microlevel, the performance of various functional subsystems (e.g., lateral control and longitudinal control) is being simulated, during which various types of failures are assumed to occur. On a macrolevel, the network simulation process embodies IBM 2250 graphic consoles by means of which failure mechanisms may be introduced and the effects on network performance (e.g., link shutdown) may be observed and various adaptive strategies evaluated.

As previously indicated, the performance of the alternative Metro Guideway configurations is evaluated and compared with that of planned conventional transportation facilities including urban freeways and public transit. The evaluation and comparison



Figure 3. Metro Guideway functions.

	SINGLE-MODE VEHICLES (VEHICLES CAPTIVE TO GUIDEWAY NETWORK)	DUAL-MODE VEHICLES (OPERATE ON STREETS AND GUIDEWAY)
PRIVATE PASSENGER TRANSPORTATION	—	DUAL-MODE AUTOMOBILES
PERSONAL TRANSIT	PERSONAL RAPID TRANSIT	(DUAL-MODE TAXICABS)
GROUP TRANSIT	MEDIUM-SIZE TRANSIT CARS, DEMAND OPERATED	DUAL-MODE DEMAND JITNEYS
MASS TRANSIT	MEDIUM-SIZE TRANSIT CARS, TRAIN OPERATED	DUAL-MODE BUS RAPID TRANSIT
FREIGHT TRANSPORTATION	TERMINAL/TERMINAL UNATTENDED CONTAINERS	DUAL-MODE LIGHT VANS

Figure 4. Classification methodology.

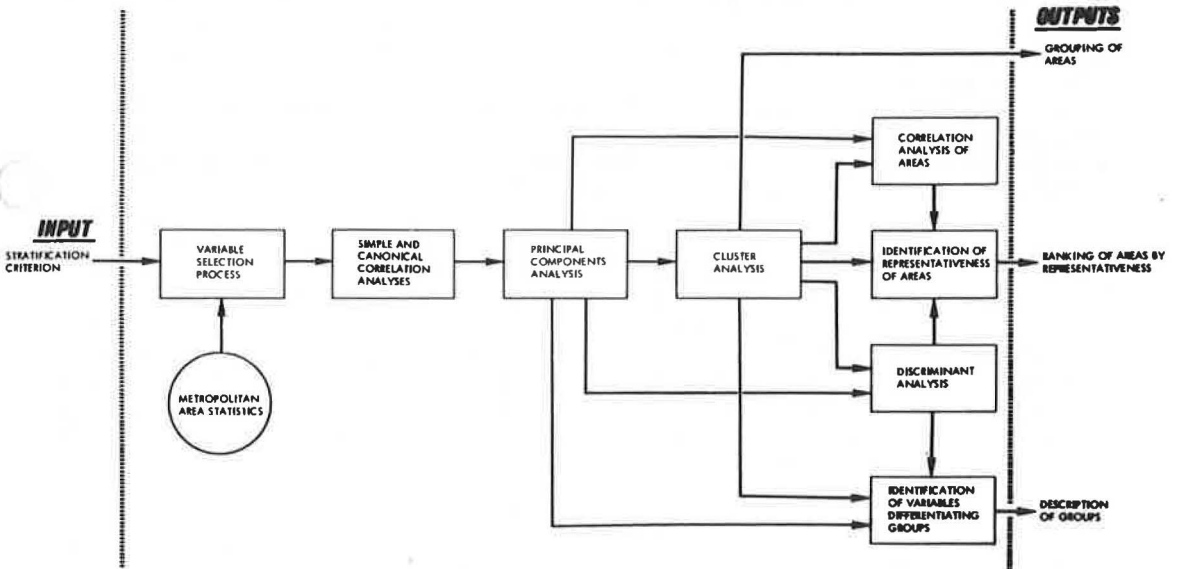

involves the analysis of the social and environmental impacts of the various designs on multiple actor groups. For example, estimates have been developed of the amount of land that would be required and the number of families, commercial establishments, and industrial plants that would be displaced by proposed new freeways in the case study area. In a similar manner, the amount and location of land required for off-line stations and dual-mode vehicle entry and exit facilities are being estimated to enable a comparative evaluation of the impacts of the Metro Guideway system. This is part of a process of evaluation that should lead to the identification and specification of the system, if any, that should be preferred and acceptable to the various actor groups in the metropolitan area and that may be implemented in a practical manner within institutional constraints.

Extrapolation of the results from selected case study areas to all metropolitan areas needs to be accomplished both to develop a total market estimate for the new systems and to enable an accounting at the national level of the overall costs and benefits of new system implementation. A method has been formulated and is outlined elsewhere (28) for the structuring and performance of sensitivity analyses and urban characteristic statistical analyses whereby the total market and total socioeconomic impacts may be estimated. Such a procedure is being followed in the Metro Guideway system study.

### CONCLUSIONS

The future requirements for transportation within the metropolitan area of the United States are of sufficient magnitude to encourage, if not to demand, consideration of new systems of urban transportation in order to achieve desirable reductions in cost, improvements in performance, and improvements in social and environmental impacts of urban transportation facilities.

A system concept, the Metro Guideway, has been outlined as a potential solution to the transportation requirements of tomorrow's metropolitan areas. Metro Guideway provides for both private automobile vehicles and public transit vehicles on a common roadway network and also includes provisions for freight movement. Vehicles and roadways are automated, including lateral control, longitudinal control, and network routing and scheduling functions. The network accommodates dual-mode automobiles, captive public transit vehicles that provide a personal rapid transit function, dual-mode bus vehicles including demand jitneys, and both dual-mode and captive freight vehicles.

The Metro Guideway system concept is being investigated and evaluated at the General Motors Research Laboratories. A number of alternative configurations are being evaluated at this time. It is currently planned that these analyses and evaluations will be performed in a number of representative areas selected to enable the estimation of the total potential benefits and impacts of the new system and the total national market for subsystems and components.

### REFERENCES

1. General Instructions. U. S. Department of Transportation, Federal Highway Administration, National Transportation Planning Manual A, 1971.
2. National Highway Functional Classification and Needs Study. U. S. Department of Transportation, Federal Highway Administration, National Transportation Planning Manual B, 1971.
3. Urban Public Transportation. U. S. Department of Transportation, Federal Highway Administration, National Transportation Planning Manual C, 1971.
4. Canty, E. T., Sobey, A. J., and Wallace, J. P. New Systems Implementation Study. General Motors Research Laboratories, Vol. 3, Feb. 1968; National Technical Information Service, Springfield, Va., PB 178 275.
5. Canty, E. T., and Sobey, A. J. Case Studies of Seven New Systems of Urban Transportation. Internat. Automotive Engineering Congress, Society of Automotive Engineers, Detroit, Paper 690038, Jan. 1969.
6. Henderson, C., et. al. Future Urban Transportation Systems: Descriptions, Evaluations, and Programs. Stanford Research Institute, Menlo Park, Final Rept. 1, March 1968; National Technical Information Service, Springfield, Va., PB 178 265.

7. Systems Analysis of Urban Transportation. General Research Corporation, Santa Barbara, Vol. 1, Jan. 1968; National Technical Information Service, Springfield, Va., PB 178 261.
8. Canty, E. T. Transportation and Urban Scale. High Speed Ground Transportation Jour., Jan. 1969.
9. Doxiadis, C. A., et al. Emergence and Growth of an Urban Region. Detroit Edison Company, Vol. 3, 1970.
10. 1968 National Highway Functional Classification Study Manual. U.S. Department of Transportation, Federal Highway Administration, April 1969.
11. 1970 National Highway Needs Report. U.S. Department of Transportation, Federal Highway Administration.
12. Kassoff, H., and Gendell, D. S. An Approach to Multiregional Urban Transportation Policy Planning. Highway Research Record 348, 1971, pp. 76-93.
13. Graves, F. M., and Rechel, R. E. Estimates of Prospective Capital Investment in Urban Public Transportation. Institute of Public Administration, Washington, D. C., Oct. 15, 1969.
14. Steinberg, E. B. Benefit-Cost Analysis and the Location of Urban Highways. Highway Research Record 348, 1971, pp. 35-41.
15. Public Attitudes Toward Urban Expressway Construction. Charles River Associates, Cambridge, Mass., 1970.
16. Ganz, A. Emerging Patterns of Urban Growth and Travel. M. I. T., Cambridge, Proj. Transport Rept. 68-1, Jan. 1968.
17. Prospects for Urban Transit. Charles River Associates, Cambridge, Mass., 1970; National Technical Information Service, Springfield, Va., PB 193 355.
18. Colcord, F. C., Jr. Decision-Making and Transportation Policy: A Comparative Analysis. Southwestern Social Science Quarterly, Dec. 1967.
19. Crain, J. L. The Reverse Commute Experiment. Stanford Research Institute, Menlo Park, Dec. 1970.
20. Joint Development and Multiple Use of Transportation Rights-of-Way. HRB Spec. Rept. 104, 1969.
21. Cunliffe, J. P. The Morgantown PRT Project. Proc., National Conf. on Personal Rapid Transit, Minneapolis, Nov. 1971.
22. Wilson, N. H. M. CARS—Computer Aided Routing System. Dept. of Civil Eng., M. I. T., Cambridge, Res. Rept. R67-12, April 1967.
23. Demand-Actuated Transportation Systems. HRB Spec. Rept. 124, 1971.
24. Westinghouse Transit Expressway. Transportation Systems Dept., Westinghouse Electric Corp., Pittsburgh, 1966.
25. Wanttaja, G. E. Automated Roadway Transportation System Configuration. National Automotive Engineering Congress, Society of Automotive Engineers, Detroit, Jan. 1972.
26. Golob, T. F., Canty, E. T., and Gustafson, R. L. Toward the Stratification and Clustering of Metropolitan Areas. Operations Research Society of America, Dallas, May 1971.
27. Howson, L. L. Computer Simulation for an Automated Roadway Network. National Automotive Engineering Congress, Society of Automotive Engineers, Detroit, Jan. 1972.
28. Canty, E. T., and Golob, T. F. A Procedure for Estimating the National Market and Total Socio-Economic Impacts of New Systems of Urban Transportation. General Motors Corp., Res. Pub. GMR-1152, Nov. 1971.



# BUXI: DEMAND-RESPONSIVE BUS EXPERIENCE IN THE NETHERLANDS

Geurt Hupkes, Centre for Transportation Surveys, Utrecht, Holland

BUXI combines features of bus and taxi. It can be classified as a first-phase, demand-responsive bus system. New system thinking in Holland has been leading to the construction of a decision model involving many-to-few service for suburbs with 3,000 to 7,000 population, at distances of 1 to 2 miles from town centers and railway stations, and by buses carrying 11 to 23 passengers (11 seated). There would be scheduled routes and scheduled timetables, and no scheduled stops would be made except at terminals. Door-stop pickup and discharge would be possible extras. BUXI has been operating in Emmen on an experimental basis since May 1970. Experience and financial results of this project are discussed and illustrated. The practical difficulties encountered in the promotion of innovation in urban public transportation are discussed.

•THE GENERAL transportation scene in my country does not differ much from that in other western nations except that the Netherlands is about as big as Connecticut and New Hampshire combined but has a population 6 times larger than the population of those 2 states. This fact gives some idea of the density of population.

We now have 200 motor cars per square mile, and if present trends continue we will have 500 of them in the year 2,000. For comparison, the United States has 8 times fewer cars per square mile. This difference will grow, for car ownership in the United States shows a lower rate of increase than it does in Holland.

In terms of gross national product per square mile, Holland is second in the world, after Japan, and is far above the United States. If you consider this proportion a measure of the pressure a nation lays on its natural environment, you could say that against every unit of pollution in the United States stand 8 units in the Netherlands and 10 in Japan. This gap again seems to get wider, for the growth of the national product is faster in Japan and in Holland than in the United States.

These 2 trends point to one of the basic conflicts of our society: the lack of balance between prosperity and well-being. In my opinion, a reappraisal of many traditional and valued ways of thinking and acting is necessary. One of the areas in need of re-balancing is the transportation field.

The balance between private and public transportation—expressed in number of trips made—will have to shift in favor of collective modes of transportation because they use less land and other resources, cause less pollution of all types, and possess a built-in higher level of safety for users and nonusers.

The advantages of public transportation, however, can be felt in the long run only. In the short run, in the daily individual choice of mode of transport, the advantages of private transportation normally are overwhelming. The emotional impact of the motor-car on its owner and user surpasses that of almost all public vehicles and can, as has been said, be compared to the thrill of riding a thoroughbred horse or a fast speedboat.

Even more important is the quality of the transportation product. Public transportation fundamentally works along a line, and one can only enter or leave the system at certain fixed places. Private transportation works from any point in an area to any other point.

In our research on innovation of urban public transportation, we tried to upgrade quality as well as emotional impact. Doing so, we almost invariably hit on some kind of demand-responsive system. In the United States, large computer-aided bus systems



and systems for guideway-bound, small automated vehicles are being developed. We decided to keep to non-guideway-bound systems and leave the computer out of the picture.

The reasons are that in Holland all towns have local bus services or regional bus lines serving local needs. However, suburbs do exist that are not integrated into these existing networks. This limits the scale of new systems currently needed. Dispatching can be done manually instead of electronically. Second, only half of all families own a telephone. Public telephones would have to be installed along the route, and people would have to walk to a street telephone, call the bus, and then wait. This is no different from the existing situation. Third, and most important, heavy passenger volumes are not expected in the suburbs where there is now no public transportation. If acceptable vehicle occupancy levels were reached, the headways between vehicles would have to be rather long. In a system acting on demand only, this would mean maximum passenger waiting times exceeding 10 min, which we think is about the limit for quality.

What gradually emerged was a system with the following characteristics:

1. Fixed route but no fixed stops—passengers signal driver to stop anywhere along route (the option of leaving the route and giving door-stop service is an important feature);
2. Scheduled and published timetable;
3. Small, comfortable buses on which 10 to 12 passengers can sit and the same number stand (headroom for standing passengers and ample space for luggage are provided);
4. No more than 1 vehicle on the road at a 30-min headway (this restricts costs to 1 vehicle plus its reserve);
5. Connections among a suburb and at least 2 main attraction points such as the town center, the railway station, the hospital, or a shopping center;
6. Distances of 1 to 2 miles between terminals and the beginning of the built-up area of the suburb;
7. Suburb population of no more than 7,000 to 10,000 people; and
8. Tickets costing as much as the market will bear.

We called this many-to-few system BUXI (Fig. 1). It is defined for 1 suburb; if a suburb is added, another BUXI service would have to be added too. It can be considered a first step toward a fully demand-responsive system like dial-a-bus.

The first BUXI project was in Emmen, a rural town turned industrial in the northern part of the country. It has a population of 36,000, and the new suburbs were served by stops at the regional bus lines radiating to the center. One of these, Emmerhout, had been built between 2 existing highways and did not possess a bus line. Its street network was designed to keep through traffic away from the access roads and parking areas where the houses are located. Population was 3,500 and will increase to 13,000.

The town's administrators have a standing reputation for dynamism and innovation. So have the managers of the Drenthe Regional Bus Company, who asked the Center for

Figure 1. BUXI in service.



pickup at doorstep



arrival at railway station

Transportation Planning to act as a consultant. Netherlands Railways has shown interest in view of the possibility of extending BUXI to its other subsidiary bus companies.

The population of Emmerhout appeared to be 80 percent lower middle class and 20 percent upper middle class. Car ownership amounted to 50 percent more than the national average. We introduced the BUXI idea to the people and got a favorable response; 50 percent reacted very positively, and 30 percent said they would use BUXI when the car was in repair or the weather too bad to use the bicycle. Based on stated intentions to use BUXI for certain trips, we estimated the passenger volume to be as expected.

We were proved to be wrong, however, because of the well-known habit of interviewees to be friendly to the interviewer. We knew this, but did not know by how much we would err. In the first 12 months of operation, BUXI carried 50,000 passengers, or 30 percent fewer than forecast. The fare might have been a contributing factor. A ticket cost 1 guilder, which is about 50 cents and about twice the fare usually paid in Holland for a local bus ride. We assumed that people are willing to pay more for better quality. If this is always true, it should be possible to keep innovative public transport systems out of the red even with the 20 percent increases in personnel costs that we have had for several years now. The price the market will bear, however, appears to be lower than that needed for profitable operation, especially in times of rapid inflation.

Another feature in which the facts proved us wrong is the attraction of doorstep service. Clients telephoning in advance were picked up at their homes, and passengers in the vehicle could ask the driver to drive to their front doors. These deviations could run up to a maximum of 150 miles from the fixed route, as defined by the street network. This service was free of charge and existed on half of the runs, for we could not allow room in the timetable to extend it to all the runs.

The bookings could be made very quickly: Sometimes the driver received the radio message while on his way to the suburb, so the passenger would wait only a few minutes. But the number of people using this truly demand-responsive facility has been limited. We estimate that 2 percent of all trip-makers have been doing so in the first year of operation.

Also, few people used the service regularly; 80 percent of the users averaged 9 pickups or discharges per year. Only 20 percent of the users were regular customers, averaging one trip per week, and they amounted to 3.6 percent of all families in the suburb.

The reasons behind this somewhat disappointing development are probably the short distance to the sidewalk where BUXI can be stopped and the trip-maker's reluctance to put the driver and his fellow passengers to trouble with detours for his sake. The fact that in a small community many people know each other personally reinforces this handicap. Anyway, when the possibility of rerouting past a new hospital came up recently and we had to decide whether to trade off the time allowed for pickups and discharges for the longer fixed route, we decided in favor of the fixed route and the doorstep service was discontinued. After all, you cannot force service down people's throats. The possibility of telephoning to reserve a seat remained.

Perhaps the conclusion is that the combination of a fixed route that entirely covers an urban area and the option of doorstep service is not viable. If this is true either you have to have fixed routes that cover the area less intensively so that deviations become meaningful, or you have to abolish the fixed route altogether and run on demand only. For the latter, more than 1 vehicle is needed in order not to exceed the client's waiting time of 10 min. This seems to be guaranteed only in larger towns with heavier passenger volumes. Chances for that in Holland and most other European countries do not exist now. Existing bus networks are still not bad enough and not expensive enough. The turning point will come when passenger volumes have decreased and costs have increased still more. The mood for innovation will then come more naturally.

I can illustrate this with the Emmen case. There, a conventional bus line would eventually produce a 60 percent higher deficit than BUXI. Yet, the deficit incurred in BUXI's first year amounted to 60 percent of the expenses, and the deficit in the second

year is in the same range. When the suburb has reached its full growth, the deficit could fall to 30 percent of the expenses.

Costs of BUXI operation do not differ much from those for ordinary buses. Personnel costs are the same, and the cheaper small bus has to be depreciated faster. The difference lies in the fares. Although we started to double the price of the fare, experiments to establish the optimum trade-off between higher fares and loss of potential passengers remain to be carried out. In Emmen, a multiride ticket with 25 percent reduction was recently introduced. This is expected to lead to somewhat better financial returns.

The future for BUXI in Holland is uncertain. The Department of Transportation is still examining the desirability of subsidizing the Emmen project. Emmen municipality has offered to cover 25 percent of the losses. Meanwhile municipal authorities in other towns suited for BUXI are planning to start feasibility studies. Other potentials have not materialized because only a few bus companies and municipalities are really attracted by the role of the pioneer. There were also cases we had to turn down because they did not fit the BUXI characteristics. We want to apply our model rather rigidly to select the cases most likely to succeed, for one BUXI failure will cause more damage than 10 experiments not started, so to speak.

An essential to get the heavy stone over the top of the hill lies, in my opinion, in a more active participation of the government. Up till now, the Department of Transportation has restricted itself to the making of encouraging noises and a willingness to change the law that says that buses within city boundaries can only stop at officially established stops. But the innovation of urban transportation calls for more than that. One of my hopes is the Organisation for Economic Co-operation and Development in Paris, working steadily at the integration and stimulation of the isolated attempts of innovation.

# OPERATIONAL EXPERIENCES WITH DEMAND-RESPONSIVE TRANSPORTATION SYSTEMS

Daniel Roos, Department of Civil Engineering, Massachusetts Institute of Technology

Demand-responsive transportation systems provide a personalized point-to-point service by responding to individual customer requests. There are no fixed routes and schedules. A dispatching center receives telephone requests from customers requesting service and assigns vehicles to service the customers. The objective is to provide efficient direct service to each customer but to group on the same vehicle customers with similar origin-destination pairs and thus reduce the cost of service to each customer. Demand-responsive transportation systems have been implemented in Ann Arbor, Michigan; Batavia, New York; Mansfield, Ohio; Columbia, Maryland; Columbus, Ohio; Bay Ridges, Ontario; Emmen, The Netherlands; and Regina, Saskatchewan. These new systems are examined with respect to vehicle dispatching, ridership, economic feasibility, type of service, and overall impact. The systems' similarities and all differences are compared. Future directions in demand-responsive transportation based on observed system performance are discussed.

• EXTENSIVE research on demand-responsive transportation systems has been conducted by many organizations during the past 5 years (1, 2). Recently, several demand responsive transportation systems have been implemented throughout the world. This paper describes initial experiences with these systems from a number of perspectives including technical feasibility, service characteristics, customer demand, and economic feasibility. Comparisons of the different operational systems and directions for the future of demand-responsive transportation are suggested.

Demand-responsive transportation systems commonly referred to by acronyms such as dial-a-bus, dial-a-ride, demand jitney (D-J), demand-actuated road transit (DART), computer-aided routing systems (CARS), and Genie provide a personalized point-to-point service by responding to individual travel requests. There are no fixed routes and schedules. Instead, a dispatching center receives telephone calls from customers and assigns vehicles to service the customers. The objective of the dispatching operation is to provide efficient, direct, point-to-point service to each customer but to group customers with similar origin-destination pairs on the same vehicle and thus reduce the cost of service to each passenger.

Research results suggest that demand-responsive transportation systems complement conventional fixed-route and scheduled systems. In low- and medium-density areas, they can provide a total transportation service where conventional fixed-route buses are not economically feasible. In higher density areas, they can provide feeder service to line-haul facilities and thus fill the existing void between conventional transit and taxi service. However, until these systems are implemented and tested, one can only speculate on their ultimate role.

## IMPLEMENTED SYSTEMS

Eight recently implemented demand-responsive systems are described below. Many of these systems have been operating for only several months; hence, the data are of a preliminary and, therefore, tentative nature. Nevertheless, preliminary data are often sufficient to gain important insights into this potential new form of transportation.



Although all of the systems described can be classified as demand responsive, they differ from one another in many respects. One of the most significant differences relates to the type of service provided and the degree of demand responsiveness.

The 3 systems described first (Mansfield, Ohio; Emmen, The Netherlands; and Dayton, Ohio) are examples of route-deviation service where a vehicle follows a basic fixed route but deviates from the route to provide door-stop service on request. The next system described is (Bay Ridges, Ontario) an example of many-to-one service (many origins to one destination and vice versa). The 2 systems described next (Ann Arbor, Michigan, and Regina, Saskatchewan) provide many-to-few service (many origins to a few destinations and vice versa). The 2 systems described last (Columbia, Maryland, and Batavia, New York) are examples of many-to-many service (many origins to many destinations). Whereas the route-deviation services have limited demand-responsive characteristics, the many-to-many services represent completely demand-responsive systems. Many-to-one and many-to-few systems are progressively more responsive than route-deviation systems but less so than many-to-many systems.

### MANSFIELD, OHIO, SYSTEM

A 13-month route-deviation experiment was implemented in Mansfield, Ohio, a community of 60,000 people (3, 4). The experiment was jointly undertaken by the Richland County Regional Planning Commission, the Transportation Research and Planning Office of Ford Motor Company, and Mansfield Bus Lines, Inc., with the cooperation of the city of Mansfield.

The regular Mansfield bus system consisted of 13 fixed-route bus lines radiating from a central point in Mansfield City Square. Twice an hour all buses met at the Square to allow easy transfer among bus lines. One of these bus routes serving 3,000 to 4,000 people in the Woodland area of Mansfield was discontinued in December 1969 because of a lack of patronage. This route was then reinstated at the end of the month as a route-deviation service.

The new service consisted of a combination of normal fixed-route and demand-responsive service. An 11-seat Ford Courier vehicle traveled a specified route but deviated from the route to pick up or drop off passengers within a prescribed area. The vehicle was equipped with the telephone communication equipment so that customers requesting service could directly call the vehicle driver. The driver would determine whether he had sufficient time to detour from his route and still maintain his basic commitment to rendezvous at the City Square each half hour. For this door-stop service, customers were charged an extra 15 cents above the basic 35-cent fare. The service was provided 6 days a week, 11 hours a day (7:15 a.m. to 6:15 p.m.) except on certain holidays.

Significant results observed during the 13-month test were as follows:

1. The driver was able to perform as many as 8 deviations per 30-min period while maintaining his half-hour schedule. Generally, however, the driver performed fewer than 2 or 3 deviations for each run because of a lack of customer demand.
2. Nineteen percent of all passengers using the bus service chose the door-stop option. (A person could still board the bus along the fixed route and pay the normal 35-cent fare.) However, because only 75.9 persons/day rode the bus, the 14.4 people requesting door-stop service represented a small demand level.
3. Older females who had no driver licenses were the largest users of the door-stop option. A significant number of domestics traveling to Woodland, a high-income area, used the service.
4. The route-deviation service did not attract significant new ridership to the route. The primary users of the new service were people who previously used the fixed-route bus.
5. Addition of the route-deviation service improved the overall financial condition of the route compared with the previous fixed route, but it was still not able to cover direct operating costs.
6. The small Ford Courier vehicle performed extremely well. Daily operating costs were significantly lower than those for conventional transit equipment.

7. A survey of users and nonusers of the service indicated that the most desired improvement to increase patronage would be to provide additional destinations. That is, the users wanted a more generalized many-to-many service rather than the somewhat limited route-deviation service.

The Mansfield route-deviation service was discontinued in January 1971. Since then, problems developed relative to financing of the entire Mansfield Bus Lines system, and the system was discontinued in June 1971. This is unfortunate because the Mansfield system was quite innovative in many different respects and was successful from both a financial and service viewpoint up to its final day of operation.

#### EMMEN, NETHERLANDS, SYSTEM

BUXI (BUs, taXI) is a route-deviation type of service implemented in May 1970 in Emmen, The Netherlands, a town of 36,000 (5). The service runs among the small suburb of Emmenhout, containing 4,000 people, and the town center and railroad station in Emmen, a distance of only 1 to 2 miles. Service is provided daily from 5:41 a.m. to 12 midnight. Two 11-seat Mercedes Benz 0309 Minibuses are used, which carry 23 passengers including standees. Three different types of service are combined: a basic fixed-route service, a route-deviation service with the deviations preplanned by a dispatcher, and a one-to-many service with the stops determined by the driver. The vehicle operates in each of these 3 modes for different segments of its runs. A preliminary evaluation of the service reveals the following:

1. Seventeen percent of the families in Emmenhout have used the service; however, only 3.4 percent of the families are regular users.
2. Seven percent of all service requests are demand responsive. Eliminating those portions of the service where no demand-responsive service is available increases the percentage of demand-responsive patronage to 10 to 15 percent.
3. Revenue from the service does not cover operating costs. During the first year of operation, total expenses were 120,000 Dfl whereas income was 48,000 Dfl.
4. The portion of people requesting demand-responsive service is decreasing; however, the decrease occurred in the warm summer months.

In an evaluation of the BUXI system, the following factors should be considered: Only 50 percent of the households have a telephone; in almost all cases the maximum walk from a house to the fixed route is only 200 meters; and some residents have indicated confusion about how the system works.

#### COLUMBUS, OHIO, SYSTEM

A route-deviation service replaced a fixed-route bus operation in the Columbus, Ohio, Model Cities area on October 11, 1971. Twenty-one checkpoints are specified that correspond to major activity centers. A driver must stop at each checkpoint at a specified time. Between checkpoints, the driver can choose any route depending on existing customer demands.

The service area is 2.56 square miles and contains approximately 55,000 people. Service is provided from 6 a.m. to 9:30 p.m., Monday to Friday, and on a somewhat reduced schedule on the weekends. The Columbus Model Cities Agency has allocated \$200,000 to run the experimental service from October 1971 through June 1972.

The Columbus Transit Service is using four 19-seat Flxette vehicles to operate the service. Labor rates for drivers are approximately \$4.50/hour. Dispatching is performed by Model Cities residents. Two people dispatch during peak periods, whereas only 1 person is required in off-peak periods.

Ridership in December 1971 was 350 to 400 persons/day and increasing. Average vehicle productivity was 8 to 9 persons/vehicle/hour with maximum productivities during peak periods in the range of 12 to 15 persons/vehicle/hour. The planned fare for the new service was 35 cents, but because of the price freeze the old fixed-route fare of 20 cents was retained.

Ridership on the old fixed-route system at the time it was discontinued was approximately 600 passengers/day of which 450 to 500 trips were within the area currently served by the new route-deviation system. The new system is, therefore, currently carrying fewer passengers a day although ridership is increasing. The cost of providing service using the route-deviation system is lower, however, than that for the fixed-route operation because the number of daily route-miles traveled with fixed-route buses was almost twice the daily route-miles for the route-deviation service.

#### BAY RIDGES, ONTARIO, SYSTEM

Bay Ridges, a community of 4 square miles and 14,000 people and 20 miles from Toronto, is serviced by the GO Transit Commuter Railroad. A many-to-one demand-responsive service to and from the commuter railroad station was begun in July 1970 by the Ontario Department of Highways (6, 7). The service, provided 7 days a week from 5 a.m. till 1 a.m., is designed to meet all trains, which operate on an hourly schedule in the off-peak hours and on a 20-min schedule in the peak-hour periods of 7 to 9 a.m. and 5 to 7 p.m. Four 11-seat Ford Econoline vehicles are used and cover 4 zones of Bay Ridges. A fare of 25 cents is charged, which is expected to cover 50 percent of the basic operating costs (a general policy for the Department of Highways). The basic wage at the beginning of service was \$3.02/hour for drivers and \$3.30/hour for dispatchers. All dispatching is performed by a single person. Users must call at least 1 hour before making a trip so that the manual dispatching operation is somewhat simplified.

Weekday ridership during the first year of operation has increased from approximately 200 to 465 passengers/day. Maximum productivities of 20 to 25 passengers/vehicle/hour are achieved during the afternoon peak hours. Saturday ridership averages 185 trips/day, while Sunday ridership is approximately 90 trips/day. Recently, a many-to-many service was added during the off-peak hours and carries 75 to 80 passengers/day.

The cost of operating the system during the first year was \$7.19/vehicle-hour. Recently, driver wages were increased, and the new wages increase the cost to \$7.75/vehicle-hour.

GO Transit has compared the costs associated with its demand-responsive operation with a comparable fixed-route bus operation, as follows:

<u>Expense</u>	<u>Cost per Revenue Mile (cents)</u>	
	<u>Demand Response</u>	<u>Fixed Route</u>
Capital	9	7
Overhead	28	21
Maintenance and fuel	9	21
Operators' wages	<u>33</u>	<u>33</u>
Total	79	82

The 2 significant differences in the GO Transit figures are for overhead and for maintenance and fuel. The difference in overhead represents the cost of the dispatching operation. The differences in maintenance and fuel reflect the newness of the dial-a-bus vehicles and the less expensive operating costs of the smaller vehicles.

During the first year of operation the average cost per trip was 69 cents. Based on existing patronage, that figure is now reduced to 60 cents/trip. The economic objective is for the service to cover 50 percent of its costs. With the current fare of 25 cents, this objective is almost being realized. To ensure that it will be satisfied in the future, GO Transit is proposing the following 3 changes in the service:

1. Increase the fare from 25 to 30 cents;
2. Eliminate Sunday service where there is low patronage and the average cost per trip is approximately \$1.35; and

3. Eliminate the dispatching service after 9 p.m. on weekdays and 4 p.m. on Saturdays.

Currently, only 1 or 3 people call in for service after 9 p.m. during the week and after 4 p.m. on Saturday. Most service during these hours is prebooked earlier in the day or on standing request for the same service each day.

Current plans are for the municipality to take over the service from GO Transit, which plans to implement several additional similar services throughout Ontario.

#### REGINA, SASKATCHEWAN, SYSTEM

A many-to-few telebus service was started in Regina, Saskatchewan, on September 7, 1971 (8, 9). The service is being sponsored by the Provincial Department of Highways and Transportation and operated by the Regina Transit System. Engineering and development costs are being shared equally by the federal, provincial, and city governments; capital costs and administrative costs are paid by the city. Revenues from the system are expected to cover direct operating costs.

The telebus service area is approximately  $2\frac{1}{2}$  square miles and contains 18,000 people. It is a nonhomogeneous area; 1 corridor in the area has densities as high as 25,000 persons/square mile. The primary objective of telebus is to serve as a feeder to a fixed-route arterial bus line. Several other major activity centers are also served, although 90 percent of the use is for feeder service.

Telebus service is available from 6:45 a.m. to 11:35 p.m. Monday through Saturday. Six buses operate during the peak hours, and 3 buses operate during off-peak hours. The schedules are established by the use of manual dispatching techniques so that telebuses rendezvous with the fixed-route buses every 15 min during the peak-hour period and every 30 min during the off-peak-hour periods. Standard 42-passenger buses are currently being used for telebus service, although smaller minibus vehicles are being investigated.

Users of telebus are encouraged to book their trips in advance. Currently, 40 percent of the riders are prebooked, while the remaining 60 percent call when service is desired. A call for service must be made at least 20 min before pickup time. One person handles the manual dispatching operation.

The cost of telebus service is 35 cents; a free transfer is provided to the arterial bus, whose normal fare is 25 cents. A monthly pass may be purchased for \$12.00, and special rates for students and children are also provided.

Ridership as of December 1971 was 1,000 passengers/day and increasing. As many as 22 passengers were being carried on a single run, and peak-hour productivities as high as 30 passengers/vehicle/hour have been achieved. Average vehicle productivities throughout the day are 15 persons/vehicle/hour.

One portion of the area was previously served by a fixed-route bus that ran 7 hours/day, cost 25 cents, and carried 50 passengers/day. Currently 400 passengers/day from that neighborhood are using the new service even though the fare is 10 cents higher.

The labor rate for drivers is \$3.83/hour and for dispatchers is \$4.75/hour. Direct operating costs are approximately \$7/vehicle-hour. If the entire 35-cent fare is credited toward Telebus operations, approximately 75 percent of the operating costs would currently be covered by fare-box revenue.

#### ANN ARBOR, MICHIGAN, SERVICE

A 3-vehicle, many-to-few demand-responsive service was started on September 22, 1971, in a 2.3-square mile area of Ann Arbor, Michigan, containing approximately 10,000 people. The service is being sponsored by the state of Michigan to determine demand and cost implications of providing demand-responsive service. Funding of \$56,000 is provided from the state, and \$33,000 is provided from local public and private sources to conduct the experimental service. The service is expected to generate \$91,000 in revenues during its first year of operation.

The system is operated by the Ann Arbor Transportation Authority from 6:30 a.m. to 6 p.m., Monday to Thursday and on Saturday. On Friday, the service runs from



6:30 a.m. till 9 p.m. Ten-seat Ford Econoline and Ford Courier vehicles pick up people anywhere in the service area and then proceed to the downtown area where they drop people off at specified points around a loop. A fare of 60 cents/trip or 10 rides for \$5.00 is charged.

Vehicle scheduling is performed by a single person who answers the phone and establishes the vehicle routes. This dispatcher is paid a basic wage of \$4.35/hour. Drivers are paid \$4.15/hour.

By December 1971, patronage had increased to 190 passengers/day. Vehicle productivities during the peak-hour periods have been as high as 20 passengers/vehicle/hour; average vehicle productivity is 8 passengers/vehicle/hour.

An interesting aspect of the Ann Arbor service concerns a recent court decision brought by the local taxi companies against the proposed new service. The taxi companies lost the case, and the service was allowed to begin. The judge ruled that dial-a-ride was different from taxicab service because the vehicle carried several people and a dial-a-ride passenger was not free to specify a desired route.

### COLUMBIA, MARYLAND, SERVICE

Columbia, Maryland, is a new community midway between Washington, D. C., and Baltimore, Maryland, planned to have a population of 110,000 by 1980. Currently, the population is approximately 16,000 people. In January 1971, a demand-responsive transit system replaced a fixed-route system that was carrying only about 30 to 60 passengers/day before it was discontinued (10, 11). The new demand-responsive system provided 2 different types of service. Easy Rider service was basically a home-to-work type of subscription service similar in concept to the Premium Special service in Peoria, Illinois (12), and the Maxi Cab Commuter Club in Flint, Michigan (16). The service was provided during the morning and evening peak-hour periods (7:30 to 8:30 a.m. and 5:00 to 5:30 p.m.) to employment locations in Columbia for a fare of 35 cents/ride or 10 rides for \$3.00. Between 8:30 a.m. and 11:00 p.m., a many-to-many service called CAR (call-a-ride) was provided for 25 cents/trip or 10 trips for \$2.25. Initially, 2 minibus vehicles were used, although a third vehicle was quickly added in February 1971 to handle increased demand. Vehicle dispatching was manually operated from a central control facility. Analysis of the service indicates:

1. A significant demand for CAR occurred very quickly. After the first month daily patronage averaged 250 to 300 passengers/day compared with only 50 passengers/day on the discontinued fixed-route service. The patronage for Easy Rider was 35 passengers/day.
2. Technical difficulties were encountered in the dispatching operation. Only a single phone line was provided with no facility to hold incoming calls (over 500 busy signals were recorded in a single day). Dispatching was performed by nonprofessionals using minimal dispatching aids (a map with pins and slips of paper).
3. The level of service provided often deteriorated as the demand for service increased. Several hours a day the wait time before a vehicle arrived was 1 hour or more. Even the addition of a third vehicle did not markedly improve service. Analysis of a typical day's operation indicated that 65 percent of the passengers were picked up within 15 min, 19 percent were delayed 15 to 30 min, and 16 percent waited more than 30 min.
4. The vehicle productivity averaged 5 to 6 people/vehicle/hour.
5. The system provided an important public service. A survey of Columbia residents asked them to rate 22 services provided by the community. Fifty-nine percent rated CAR very important, and 21 percent rated it somewhat important. The only 2 other services to get higher ratings were maintenance of open space and providing early childhood education.
6. The system was extremely expensive to operate. During its final month of operation it is estimated that the average cost was \$2.10/trip.

Basic revisions were made in Columbia's transit system in September 1971 to correspond with the opening of a major new shopping center in downtown Columbia.

Easy Rider was discontinued, and CAR is now offered only between the hours of 6:30 and 8:30 a.m. and between 5:30 and 11:00 p.m. From 8:30 a.m. to 5:30 p.m., fixed-route buses serving the mall have replaced CAR service. The fare for CAR was increased to 50 cents but was then rolled back to 25 cents as a result of the price freeze.

#### BATAVIA, NEW YORK, SYSTEM

On October 11, 1971, a 3-vehicle demand-responsive service replaced a 2-vehicle fixed-route operation because of declining ridership and increasing costs. The service was planned by the Rochester-Genesee Regional Transportation Authority and is operated by Batavia Bus Lines. The new many-to-many demand-responsive system provides service Monday to Friday from 6:00 a.m. to 6:00 p.m. to the population of 18,000 people anywhere within the city limits of 4.3 square miles. In addition, a community college and a shopping center just outside of the city limits are served. During the morning and afternoon peak periods, subscription service is offered consisting of home-to-work and return and home-to-school and return. During the off-peak hours the same 23-seat Flxette vehicles provide many-to-many service.

Manual scheduling is performed by a telephone operator and dispatcher. Because both people are frequently idle, consideration is currently under way to use only 1 person in the off-peak periods. The average pickup delay is 10 to 20 min. During peak periods maximum waiting times of 30 min have occurred. The average travel time is approximately 10 to 15 min.

Ridership has increased constantly since the introduction of the service. In December 1971, ridership totaled approximately 360 passengers/day of which 180 were subscription customers and 180 were many-to-many customers. A fairly large increase in ridership occurred when cold weather began. The average vehicle productivity is 8 passengers/vehicle/hour for many-to-many service and 12 passengers/vehicle/hour for subscription service.

Fares are 60 cents for many-to-many service and 40 cents for subscription service. The economic objective of the service initially is to do no worse than the former fixed-route service, which lost approximately \$10,000/year. The eventual objective is to produce a break-even operation. Based on the current ridership figures and continuing upward trends, these objectives appear attainable. The base driver wage of only \$2.35/hour is quite low; thus, a break-even situation may be easier to obtain than in some other systems.

Current plans are to add 2 additional vehicles in the near future and to continue adding buses as the demand increases.

#### COMPARISON OF IMPLEMENTED SYSTEMS

The systems in Bay Ridges, Mansfield, Columbia, and Emmen have operated for 1 year or longer, whereas the systems in Ann Arbor, Batavia, Columbus, and Regina have operated for only several months. These later systems have not yet reached steady-state conditions. Nevertheless, it is interesting to compare the various systems to see what preliminary conclusions regarding demand-responsive transportation can be formulated. The various implemented systems are contrasted below from several standpoints.

##### Vehicles

Although different brands of vehicles have been used, they can be grouped into 3 basic categories: van vehicles with approximately 10 to 12 seats, minibus vehicles with approximately 19 to 25 seats, and standard buses with approximately 40 seats. Only Regina is using the large buses and has indicated plans to switch to smaller vehicles. Vehicle capacities of 10 appear sufficient for many-to-many service and for some many-to-one applications, although Bay Ridges and Regina do carry as many as 20 passengers at one time on a vehicle. Route-deviation and subscription service generally require vehicle capacities of 20 seats, if sufficient passenger demand exists. The smaller van and minibus vehicles are favored because they are more acceptable

on residential streets in lower density areas and have operating costs somewhat lower than those of standard vehicles. All operators have indicated the need for improved small bus design.

### Type of Service

Although all of the implemented services can be classified as demand responsive, each of the systems offers a somewhat different type of service. As previously stated, Mansfield, Emmen, and Columbus are different variants of the route-deviation idea. Toronto began as a many-to-one service with a many-to-many service recently added in the off-peak hours. Ann Arbor and Regina provide many-to-few services, although most service in Regina is to one point. Columbia was and Batavia is basically a many-to-many service with subscription service during the peak hours.

Three of the systems provide different demand-responsive services at different hours of the day. With a combination of different types of demand-responsive services, the system can better meet the changing needs of the users during the day and achieve a better utilization of personnel and equipment during the service hours. The peak-hour services tend to be less dynamic but handle more people, whereas the off-peak services are more dynamic but handle fewer people. The concept of system balancing is already important in the design of demand-responsive transit services.

It is not surprising to see so many different types of service represented in the implemented systems. Different communities have different needs, so different types of demand-responsive transportation systems should naturally develop. Conventional fixed-route and scheduled systems provide few options. A basic capability of demand-responsive transportation is the overall flexibility of the system and can be used in different ways to achieve different goals.

### Service Areas

All implemented systems utilize 6 or fewer vehicles and serve populations of no more than 20,000 people. In contrast, the research results (1) indicated that dial-a-ride would be most promising in communities with populations between 25,000 and 250,000 people. There are several reasons why smaller systems have been implemented first. They are cheaper and simpler to implement and require minimal capital investment, an important factor for many small communities. Manual-dispatching techniques are sufficient to operate the systems. A small dial-a-ride fleet can cover an entire community and serve most of the origin-destination requests, whereas a small vehicle system can only service a portion of a large city. (Some of the more recent systems in Regina, Dayton, and Ann Arbor serve portions of the entire city.) Because there are generally fewer institutions to deal with in small cities, the institutional constraints are less severe.

### Dispatching Techniques

All of the implemented systems utilize manual-dispatching techniques. In Mansfield, the relatively simple dispatching was performed by the vehicle driver, whereas in the other systems dispatching was performed at a control center. In all cases, largely intuitive techniques are used including dispatching aids such as maps with pins or a magnetic map board. One or 2 people are employed to answer phone calls from customers, make dispatching decisions, and communicate dispatching information to vehicle drivers.

Manual-dispatching techniques appear adequate for the existing vehicle fleet sizes and customer requests. This is not surprising because research results indicated that manual-dispatching techniques are clearly superior to automated techniques for fewer than 10 vehicle systems (1). It will be interesting to observe how well manual dispatching performs as the current systems grow and larger new systems are introduced.

Customers using a demand-responsive system can be grouped into the following 3 basic categories: demand requests, customers who call up when they want service; standing requests, customers who call once to request repeat service the same time



each day; and prebooked requests, customers who call several hours before they wish to make a single trip.

In most systems as many as 20 percent of all trips are standing requests. The most extreme case occurs in Bay Ridges where during the peak hours fewer than 15 percent of all trips are demand requests. During other hours of the day significant numbers of standing requests also occur. This not only simplifies the dispatching operation but also results in more efficient vehicle assignments. In many respects, these systems start to have the same characteristics as subscription services where all stops are preplanned on a repetitive basis.

Many trips are also prebooked several hours ahead of time. In some cases, the prebooking is a necessity during peak periods to minimize delays that would occur if service were requested at the time a person wanted to make a trip. In the other cases, people are calling several hours before making a trip to assist in the overall system efficiency.

The large number of standing requests and prebooked trips indicate that many people do not require extreme flexibility with respect to time. These people are primarily interested in the space flexibility provided by a demand-responsive service (i.e., point-to-point service). This is extremely important to consider in the design of new demand-responsive systems where decisions must be made as to how much flexibility should be provided. As the flexibility and dynamic characteristics of the system increase, the cost of providing the service generally increases while the passenger-carrying capacity decreases. A system should, therefore, provide no more flexibility than is required for a given application.

### Fare

There is a considerable variation in the fares being charged. Columbia, Toronto, and Columbus all charge very low fares (25 to 35 cents) even by conventional fixed-route bus standards. The Toronto fare is purposely low because only 50 percent of operating costs are expected to be covered out of the fare box. The Columbus fare is low because the system is designed to serve low-income residents of a Model Cities area. The low fare in Columbia was a major reason that the cost of the operation exceeded the allocated budget. When the service in Columbia was recently changed, the call-a-ride fare was increased to 50 cents.

Higher fares of 60 cents are charged in Ann Arbor and Batavia, and a fare of 50 cents was charged in Mansfield for the route-deviation service. Even these fares tend to be somewhat low. The M.I.T. and GM research work indicated that a fare of \$0.50 to \$1.25 is required to cover all fixed and operating costs in a dial-a-ride service (1, 2). The low end of the spectrum (50 to 75 cents) represented service provided by taxi companies where labor rates are far less than for transit operations.

### Ridership

Of the 3 route-deviation systems, Mansfield represented expansion of an existing fixed-route service, Columbus represented a replacement of fixed-route service, and Emmen represented a totally new service. For the first 2 cases, route-deviation service did not result in an increase of ridership. In fact, the ridership in Columbus appears to have decreased although that conclusion might be premature. The Mansfield experiment did illustrate that a significant number of existing riders (20 percent) were willing to pay more money (15 cents) for a higher quality door-stop service. A smaller percentage of people use the door-stop option in the BUXI system even though there is no additional charge. There is, however, a real question, if one considers the small size of Emmenhout and the proximity of people to the route, whether any form of demand-responsive service was warranted.

Whereas route-deviation service does not greatly increase the area coverage, other forms of demand-responsive service do increase potential travel opportunities. The Columbia, Regina, and Batavia experiences seem to support this conclusion. Replacement of the limited fixed-route service in Columbia with a more flexible many-to-many service resulted in a dramatic 500 percent increase of ridership. In 1 neighborhood of



Regina where telebus replaced a fixed-route service, ridership increased 800 percent from 50 passengers/day to 400 passengers/day. In Batavia, current ridership on the demand-responsive system surpasses the ridership on the old fixed-route system even though the fare for the new service is  $2\frac{1}{2}$  times the fare for the fixed-route service. The Bay Ridges service has attracted significant patronage whereas a fixed-route system operated from 1967 to 1968 did not attract many riders and was discontinued.

Ridership on demand-responsive systems is subject to both short- and long-term fluctuations. None of the systems has been able to overcome completely the peak/off-peak problem although it is less severe than in previous fixed-route operations. In several cases new peak hours are developing as new users and new travel demands are served. As previously mentioned, the combination of different demand-responsive systems at different hours of the day has helped significantly to reduce the peaking problem.

Variations of ridership throughout the year is most observable in northern areas subject to severe winter weather. Preliminary results indicate that weather plays a far greater effect on demand-responsive ridership than it does on fixed-route ridership. Door-to-door service is particularly appealing during unpleasant weather.

### Vehicle Productivity

Vehicle productivity is extremely important when system efficiency and the cost of the service to each user are determined. Vehicle productivity can be either supply or demand limited. The Mansfield and Emmen cases are examples of situations where more people could have been served by the system but the additional demand did not develop. Ignoring these 2 systems for a moment, we will only consider vehicle productivities where supply characteristics have constrained the system. Average vehicle productivities on these systems have varied from a low value of 5 to 6 passengers/vehicle/hour in Columbia to a high value of 15 passengers/vehicle/hour in Regina. Most systems have average vehicle productivities of approximately 8 to 9 persons/vehicle/hour. Maximum vehicle productivities of 20 to 30 persons/vehicle/hour have been achieved in both Bay Ridges and Regina. The differences between average and maximum vehicle productivities reflect that all the system capabilities are not fully utilized during all the service hours.

The factors that most affect vehicle productivity appear to be the following:

1. Type of service. The potential for high vehicle productivity is greatest in route-deviation services and lowest in many-to-many service. The more flexible and dynamic the system is, the lower the potential maximum vehicle productivity will be. This is illustrated by the high vehicle productivities in Regina and Toronto compared with lower productivities in Batavia, Ann Arbor, and Columbia.

2. Service requests. Vehicle productivity increases as the percentage of standing requests and prebooked trips increase. Given sufficient time for preplanning, more efficient vehicle assignments can be developed. In Bay Ridges and Regina where vehicle productivity has exceeded 20 passengers/vehicle/hour, a significant percentage of customers use standing requests or prebooking.

3. Dispatching efficiency. If efficient dispatching techniques are used, more people can share the use of a single vehicle. This intuitively obvious conclusion has not yet been quantitatively verified by a comparison of the existing systems.

4. Demand density. The higher the demand density is, the higher the vehicle productivity will be. Although this was verified in simulation experiments, data from the initial operational systems have not yet been analyzed (2, 14).

5. Trip length. The shorter the trip length is, the higher the vehicle productivity will be. Here again, as in factor 4, this has been observed in simulations but the operational data have not yet been analyzed (2, 14).

6. Boarding time. The vehicle is unproductive when it must wait for passengers to enter and leave the vehicle. In most systems boarding time rarely exceeds 30 sec, whereas in Columbia a vehicle sometimes waited more than 2 min for a passenger to leave her home and board. One reason for the long vehicle boarding time in Columbia might have been the unpredictability of the waiting time. As previously noted, some

people had to wait as long as an hour for service and thus were not inclined to be ready for a vehicle to arrive.

7. Multiple pickups. As the number of multiple pickups increases, the vehicle productivity increases. Most systems service an average of 1.1 to 1.3 persons/pickup.

### Economic Implications

The cost per trip is dependent on the total cost of providing service and the vehicle productivity. The cost of providing service is largely dependent on the driver cost. For a system with few vehicles, the cost of the manual-dispatching operation is also a significant portion of the total cost. As more vehicles are added, this largely fixed cost is spread over more vehicles. Demand-responsive systems are very labor intensive. The labor rates in the implemented systems vary considerably from low figures of approximately \$2.50/hour in Batavia, Columbia, and Mansfield to high figures of more than \$4.00/hour in Ann Arbor and Columbus.

The costs of demand-responsive transit services are significantly different. The average operating cost of service in Columbia exceeds \$2/trip, whereas the average operating cost in Bay Ridges is only 60 cents/trip, even though the labor rate of \$3.04/hour in Bay Ridges exceeds the labor rate in Columbia of \$2.50/hour. The significant difference between the cost of these 2 systems is vehicle productivity and the efficiency of the dispatching operation.

In Mansfield, the additional revenue from route deviation more than paid for the small added dispatching cost. The new route deviation was, therefore, economically more viable than the previous fixed-route system. However, the new system did not produce sufficient revenue to cover operating costs.

Based on the low ridership to date, there is a real question whether the Emmen route-deviation service is an economically viable operation. Because the author is unaware of the overall objective of that system, it is not possible to make a more definitive evaluation at this time.

Although the Columbia system was a significant success in terms of generating new ridership, it was an economic failure because its costs exceeded the allocated budget. The recent changes in fare and service are intended to produce an economically viable operation. The author must, however, question the decision to run many-to-many service in the morning peak hour when demands are repetitive and fixed-route service in the off peak when demands are far more random.

The Bay Ridges system was designed so that fare-box revenue would pay for 50 percent of the operating cost. Currently, the system is approaching this objective because the fare is 25 cents and the average operating cost is 60 cents. The newly initiated many-to-many service is covering approximately 80 percent of the marginal operating costs. The planned 5-cent fare increase and elimination of late evening dispatching and Sunday service should produce the desired economic objectives.

It is premature to judge Batavia, Regina, Ann Arbor, and Columbus, for they have been operating only several months. The operators of these systems appear pleased and feel that they are approaching the predetermined economic objectives. We should, however, reserve judgment because some of these operators might be overly optimistic.

### FUTURE DIRECTIONS

In many respects it is remarkable how slowly demand-responsive systems have been implemented in terms of both demonstration projects and production systems. Encouraging research results have been reported during the past 5 years. The New Systems Study of the U. S. Department of Housing and Urban Development recommended dial-a-ride as the most promising short-term concept, yet, relatively little has happened since that study (15). The few demand-responsive systems that have been implemented are relatively small and modest. A major reason for this development pattern has probably been that the U. S. Department of Transportation, responsible for the major research in the area of demand-responsive transit, is only now about to begin service of a manually dispatched dial-a-ride demonstration project in Haddonfield, New Jersey.

In many ways this approach of initial demonstrations not involving the federal government might be appropriate, particularly in a free enterprise country. However, there are 2 real dangers. First, if many of the initial systems are poorly conceived, a promising new concept might be incorrectly dismissed. The government is in the best position to ensure that the proper demonstrations are implemented in the proper areas so that the full national significance of the concept can be evaluated. None of the implemented systems described in this paper had an extensive data collection and evaluation phase or site selection analysis associated with it. It is, therefore, difficult to gain maximum information from an analysis of the operations.

The second potential problem concerns the possibility that a large subset of demand-responsive systems may be prematurely overlooked. The initial experiences reported here give some indication of the potential for the new concept. However, one must be quite careful in interpreting these results. Smaller scale, manually controlled dial-a-ride systems may not be representative of larger scale, computer-controlled dial-a-ride systems. Although manual-dispatching techniques are most efficient for dispatching 10 or fewer vehicles they become too expensive and less reliable as the number of demands and vehicles increases.

Small manually controlled dial-a-ride systems have an important place in providing urban transportation service. However, this author believes that larger scale, computer-controlled systems will have even more impact. An operational computer-dispatching system developed by M.I.T. to run on the IBM System 360 and System 370 computers has been completed and is in the public domain. Another computer-dispatching system is currently being developed by the MITRE Corporation to operate on a Westinghouse minicomputer. The federal government has indicated that if the Haddonfield experiment is successful it will computerize it and implement a second computer-controlled dial-a-ride system in Rochester, New York. With the availability of computer-based dispatching systems and an active government program, we should shortly see the implementation of the first computer-controlled, demand-responsive transportation systems.

#### SUMMARY

Eight new demand-responsive transportation services have recently been implemented. The principal conclusions relating to these systems are as follows:

1. No 2 systems provide identical types of service. This suggests that we might expect many different types of demand-responsive service to be developed based on the particular needs of the community for which it is implemented.

2. All of the implemented systems are small manually dispatched systems serving relatively small areas. These types of systems were the easiest and cheapest to implement initially and entailed the least risk.

3. All systems except one use small vehicles with seating capacities of 10 to 25 people. Route-deviation and subscription services require approximately 20 seats, whereas general many-to-many services require fewer seats.

4. Fares for the services vary between 25 and 60 cents. The services most recently implemented tend to have fares at the upper end of this range. It would not be surprising to see newer systems with even higher fares approaching or even exceeding \$1/trip.

5. Average vehicle productivities vary between 5 and 15 persons/vehicle/hour. Maximum vehicle productivities of 20 to 30 persons/vehicle/hour have been achieved in 2 systems.

6. People are willing to spend more money for higher quality service. Many-to-one and many-to-many service can attract new riders, whereas the more limited route-deviation services have considerably less potential to attract new ridership.

7. Many implemented systems have achieved or are achieving their economic objectives. These objectives are quite different for each of the systems.

#### ACKNOWLEDGMENTS

The author is grateful to the following people who provided information used in the preparation of this paper: Robert Aex, Rochester-Genesee Regional Transportation

Authority; Wally Atkinson, Regina Transit System; Robert Bartolo, Rouse Company; Karl Guenther, Ford Motor Company; and William Howard, Ontario Department of Transportation and Communication. Each of these individuals deserves considerable thanks for his efforts in implementing the new innovative transportation services described in this paper. The transportation profession and riding public owe them a debt of gratitude for providing the opportunity to observe and use demand-responsive transportation.

#### REFERENCES

1. Demand-Actuated Transportation Systems. HRB Spec. Rept. 124, 1971.
2. Roos, D., et al. Summary Report of the Dial-A-Ride Transportation System. Dept. of Civil Eng., M.I.T., Cambridge, Res. Rept. TR-71-03, March 1971.
3. Guenther, K. The Mansfield Dial-A-Ride Experiment. Proc., Transportation Research Forum, 1970.
4. The Mansfield Ohio Dial-A-Ride Experiment. Final Rept., Richland County Regional Planning Commission and Transportation Research and Planning Office, Ford Motor Co., Aug. 1970.
5. Hupkes, G. BUXI: Demand-Responsive Bus Experience in the Netherlands. Paper presented at the 51st Annual Meeting and published in this Record.
6. Bonsall, J. A. The Bay Ridges Dial-A-Bus Experiment. Ontario Department of Highways, Downsview, Progress Rept. 1, Jan. 1971.
7. Dial-A-Bus, The Bay Ridges Experiment. Ontario Department of Transportation and Communications, Aug. 1971.
8. Regina Telebus Study. Kates, Peat, Marwick and Company, Toronto, June 1971.
9. Atkinson, W. G., Couturier, R. P., and Ling, S. Regina Telebus Study. Regina Transit System, Saskatchewan, Summary Rept., Sept. 1971.
10. Bartolo, R. A New Transit System for Columbia, Maryland. Connecticut Transportation Symposium, May 1971.
11. Bartolo, R., and Navin, F. Demand Responsive Transit: Columbia, Maryland's Experience With Call-A-Ride. Confer-In West, American Institute of Planners Annual Meeting, San Francisco, Oct. 1971.
12. Mass Transportation Demonstration Project Ill.-MTD-3, 4—Final Report. U.S. Department of Housing and Urban Development, 1968.
13. Mass Transportation Demonstration Project Mich.-MTD-2—Final Report. U.S. Department of Transportation, 1970.
14. Wilson, N., et al. Scheduling Algorithms for a Dial-A-Ride System. Dept. of Civil Eng., M.I.T., Cambridge, Res. Rept. TR-70-13, March 1971.
15. Tomorrow's Transportation—New Systems for the Urban Future. U.S. Department of Housing and Urban Development, 1968.



# EXTERNAL COMBUSTION ENGINES: PROSPECTS FOR VEHICULAR APPLICATION

Roy A. Renner, California Steam Bus Project,  
International Research and Technology Corporation, San Ramon, California

External combustion engines are discussed as possible alternatives to the internal combustion engine for vehicle propulsion. Potential advantages are low levels of exhaust pollution, quiet operation, high starting torque, and possible lower costs during a vehicle lifetime. Present experience with the California Steam Bus Project indicates that competitive road performance is obtainable with steam-powered city buses, but fuel consumption is higher than with a diesel engine. Opportunities remain open for the evolutionary improvement of thermal efficiency. Logical early applications include stop-and-go fleet vehicles.

•GASOLINE and diesel engines have been preferred prime movers for motor vehicles during a period of many years. Despite the almost universal application of the internal combustion engine (ICE), the criteria for vehicular power plants are now being seriously reexamined. Alternatives to the ICE are being reconsidered in a new light (1, 2).

The external combustion engine (ECE), of which the steam engine is the best known example, has been in use for more than 200 years. Steam power was popular for automobiles at the turn of this century. Prior to 1910, it was considered to be superior to the ICE for automobile propulsion in every way except first cost and convenience. Even then, the steam car was noted for its quietness and clean exhaust; freedom from gear shifting was also a decided advantage.

Now that air pollution, noise, and congestion are factors no longer to be ignored, both the role of the vehicle and its source of power are being evaluated anew. There is mounting evidence that the ECE can be significantly cleaner and quieter than the ICE (3, 4). Given accelerated (but expensive) development, the ECE could no doubt be applied to both private and public transit vehicles. This paper explores some of these possibilities.

Much of the present discussion will be supported by work now being done under the California Steam Bus Development and Demonstration Project (5, 6), described later in this paper.

The ECE may be defined as a power system in which the fuel is burned externally to the expander (cylinder with piston, turbine, or equivalent) and in which the products of combustion are not used as the expansive working fluid. This category includes engines using steam or other vapors as the working fluid (Rankine cycle). Stirling, Ericksson, and closed-loop Brayton cycle systems are also examples of the ECE. Technically, the open-cycle gas turbine does not fit the definition just given, for the combustion gases are used to drive the expander.

Another pertinent concept is that of the continuous combustion process. Such a process may be applied either to the ECE or to the open-cycle gas turbine. Contrasts with the ICE, in which ignition-to-extinction of the flame may take only milliseconds of time, are obvious. Opportunities for the beneficial tailoring and control of combustion processes in the ECE are a prime area for study during the next few years.

Important elements of the ECE include the following:

1. Source of heat (burner or combustor);
2. Means of transferring the heat to the working fluid (boiler, vapor generator, heater);

3. Expander, in which the heat of the working fluid is transformed into mechanical energy (turbines, piston engines, and rotary engines have all been applied);
4. Means of dissipating exhaust heat, such as a condenser, radiator, or other cooler;
5. Pump or compressor for returning the working fluid to element 2 above; and
6. Ancillary apparatus that may be required for starting, control, lubrication, speed reduction, and torque multiplication (auxiliary heat transfer apparatus such as feed-water heaters and regenerators may be used to increase the efficiency of the operating cycle).

### CALIFORNIA STEAM BUS PROJECT

The California State Assembly, with a grant from the Urban Mass Transportation Administration of the U. S. Department of Transportation, is currently sponsoring a demonstration of the feasibility of ECE power for city buses. A major objective is to demonstrate a vehicle with a competitive level of road performance but with significant reduction of exhaust pollution, noise, smoke, and odor.

Development work was begun in June 1970 on 3 power system designs, each by a different engineering contractor. By the summer of 1971, extensive bench testing of complete power systems was under way. Installations into 51-passenger buses have now been made, and road test evaluation has begun.

Features of the 3 power systems are shown in Figures 1, 2, and 3. A brief description of each, a summary of preliminary data, and the project's outlook are discussed below.

#### William M. Brobeck and Associates

The Brobeck steam bus power plant is an outgrowth of the earlier and successful Doble designs. The steam generator, for example, is based on the Doble monotube concept (7). Unlike conventional boilers, no steam drums are used. A forced circulation of water and steam is induced through approximately 1,400 ft of coiled tubing. This requires, of course, the close automatic control of the flows of fuel and water to maintain the instant availability of steam under widely varying loads.

An engine (expander) having 3 double-acting cylinders with compound expansion is employed. Piston valves are employed that have fixed cutoff of steam admission during the stroke. Because the engine is coupled via a 2-speed automatic transmission to a conventional rear axle, the rated engine speed is the same as the diesel engine replaced—2,100 rpm.

The power system has a maximum rating of 250 hp at 2,100 rpm. Under normal operating conditions, up to 200 net hp are delivered to the transmission after auxiliary loads are deducted. Steam conditions are 800 to 1,000 psi and 850 F.

In the present bus conversion, the steam generator has been installed in the original engine compartment at the rear of the bus. The engine, condensers, and auxiliary apparatus are mounted midway under the floor. Cooling fans for the condensers are hydraulically driven.

#### Lear Motors Corporation

The Lear bus power plant is unconventional in design approach. It uses a single-stage impulse turbine as the expander. Turbines are much smaller and lighter than piston engines and also eliminate the problem of cylinder lubrication at high superheat temperatures. Although steam is being used as the working fluid during field tests, extensive bench testing has been done with substitute organic vapors in this system. (A low freezing point would be a considerable advantage in cold-weather operation.)

Much work has been done by the Lear organization toward optimizing combustion and heat transfer characteristics. As a result, the size and weight of the vapor generator (boiler) have been greatly reduced over traditional steam automotive practice. This, together with the use of the compact turbine, makes possible a power system that is lighter (by hundreds of pounds) than a diesel power plant of the same power output.

## Steam Power Systems, Inc.

SPS is endeavoring to further the art of the steam reciprocating engine. A 6-cylinder, double-acting, compound-expansion engine of high specific output is coupled to a forced-circulation steam generator of the coiled-tube design. The steam is reheated between expansion stages. Electronics have been utilized to a maximum degree in the automatic controls. Because the engine delivers 12 power strokes per revolution of the crankshaft, there is an extremely smooth torque delivery over a wide range of speeds. Although piston valves with fixed cutoff are used as a design expedient in the first bus installation, a more advanced concept is under development. The advanced system uses poppet valves with variable cutoff, which should result in reduced fuel consumption.

In the SPS bus installation, the steam generator, engine, and one of the condenser cores are mounted in the original engine compartment, together with auxiliaries. Additional condenser cores are located under the floor. Each condenser core resembles a large automotive type of radiator.

## Project Outlook

Although the final technical evaluation of this project will not be completed for some months, preliminary data are now available. We are reminded that this project is primarily to provide a public demonstration and to evaluate potential; it is not intended to be a developmental advancement of the art. To a large extent, this has been a learning process to determine where the basic point of departure lies. Much relearning has also taken place.

Road Performance—Good road performance seems ensured. City buses of this size are normally fitted with diesel engines rated at 180 hp and more. ECE systems being installed in this project have been bench tested at levels exceeding 200 hp net input to the transmission. Early road trials confirm that the experimental steam power plants an yield performance equaling or exceeding that of diesel power in terms of acceleration, hill climbing, and top speed.

Exhaust Emissions—Exhaust emissions were measured by the California Air Resources Board in early October 1971. The results, expressed in grams per brake horsepower hour, are given in Table 1. The information is from limited and initial test data and is not considered absolute or necessarily representative for this class of vehicle. Future California standards for heavy-duty diesel-powered vehicles are also given in Table 1 (8).

Laboratory experiments with advanced burner designs, at Lear Motors and elsewhere, show that even the low emissions given for the steam bus in Table 1 can be considerably reduced. Future steam bus emissions can be cut to levels of less than half those shown for carbon monoxide, hydrocarbons, and oxides of nitrogen.

Sound Levels—Sound levels in the near vicinity of the Brobeck steam bus have been found to be 3 to 10 decibels lower than those for diesel-powered equipment. Because the decibel scale is logarithmic, this represents a reduction in noise intensity by a factor of 2 to 8 or more. Sound levels inside the coach, however, were similar to diesel equipment because of the arbitrary locations of mechanical equipment below the floor of the steam bus.

Fuel Consumption—Fuel consumption for the steam systems is high, being roughly twice that of the diesel engine. Much improvement from the present rudimentary state of development is needed and possible.

Safety—The question of safety arises when high-pressure steam systems are discussed. Studies conducted prior to the hardware development phase showed that well-designed systems could meet stringent requirements for operational safety. Boiler explosions, in the dangerous or destructive sense, are not possible with the continuous-tube type of steam generator. All the pressurized steam and water are contained within small-diameter tubing; even if this tubing should rupture, the result would be more of an inconvenience than a hazard (9). Special safety studies are required when working fluids other than water are used. In the California Steam Bus Project, such fluids are limited to those that are nontoxic and those that have a low flammability potential.

Figure 1. Brobeck steam generator under laboratory test.

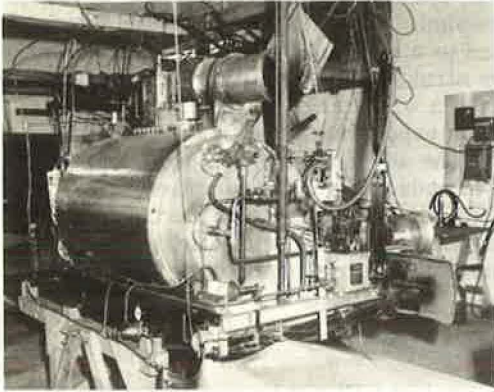

Figure 2. Prototype vapor turbine by Lear Motors Corporation.

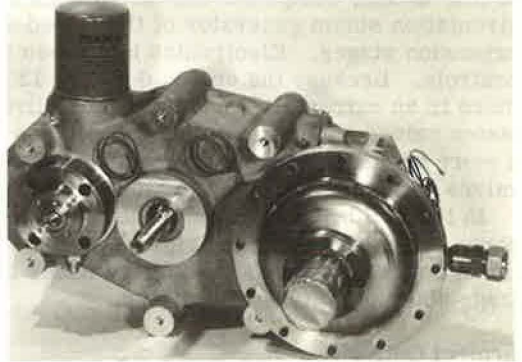

Figure 3. Crankcase assembly for reciprocating steam expander by Steam Power Systems, Inc.

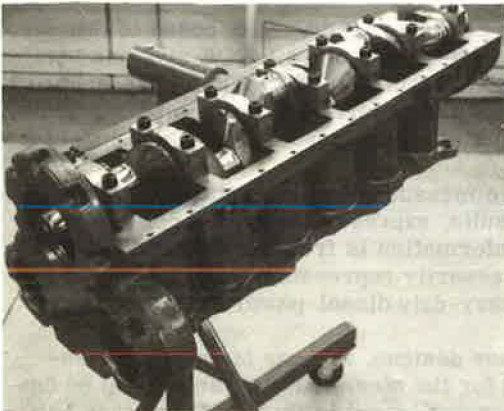

Figure 4. 1933 Besler steam aircraft engine.

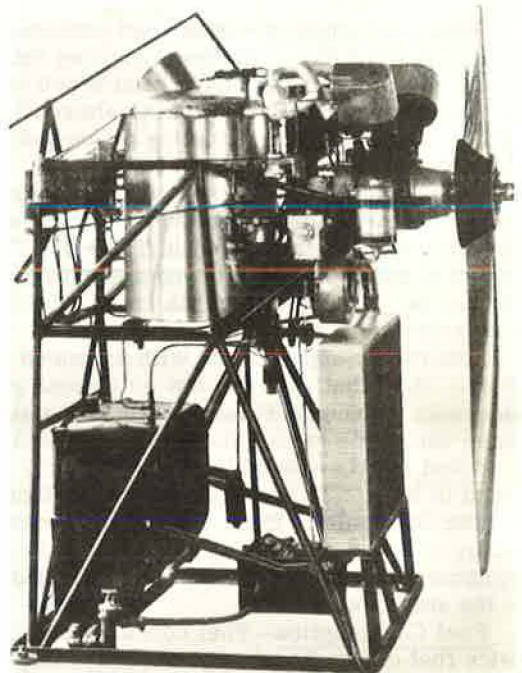

Table 1. Steam and diesel bus exhaust emissions.

Date	Vehicle	Grams per Horsepower Hour			
		CO	HC	NO <sub>2</sub>	HC + NO <sub>2</sub>
October 1971 measurement	51-passenger steam bus (Brobeck power system)	2.0	1.2	1.2	2.4
	51-passenger diesel bus (V-6 engine)	4.4	2.5	9.0	11.5
	51-passenger diesel bus (V-8 engine)	7.9	0.9	8.4	9.3
1973 standard	Heavy-duty diesel-powered vehicle	40.0	—	—	16.0
1975 standard	Heavy-duty diesel-powered vehicle	25.0	—	—	5.0



Figure 5. Trends in development of automotive steam generators.

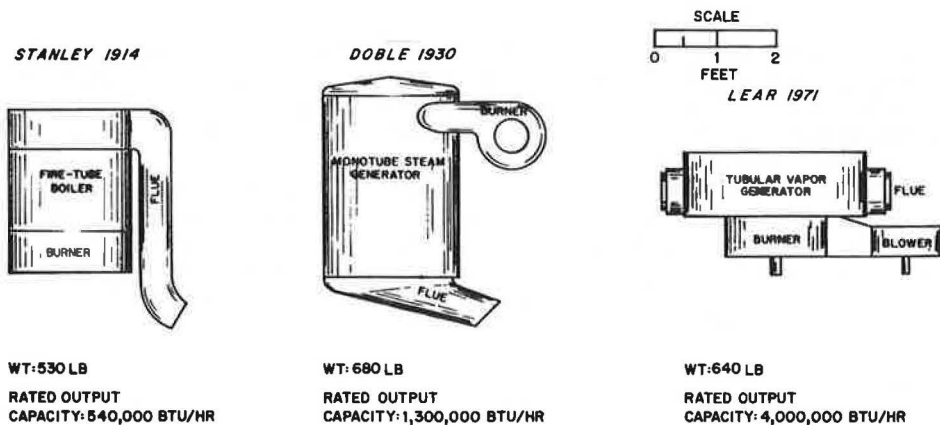
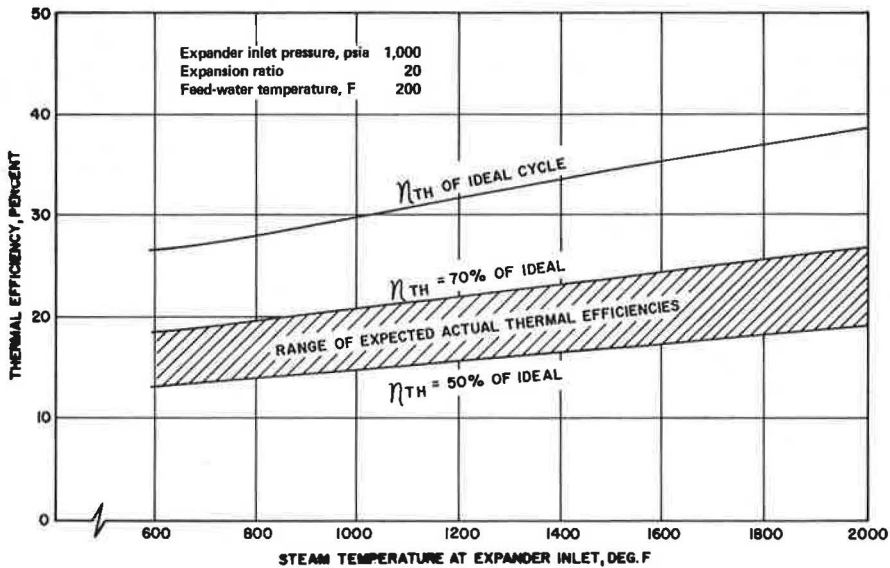

Figure 6. Influence of steam temperature on thermal efficiency ( $\eta_{th}$ ) of Rankine cycle system.



## TRENDS AND FUTURE POTENTIAL

Size and Weight

The photograph shown in Figure 4 should dispel any notions that ECE systems are inherently heavy, clumsy machines. In 1933, William Besler flew an airplane powered by the steam system shown. The complete condensing steam power plant had a dry weight of less than 5 lb per shaft horsepower. It is certainly reasonable that even higher power-to-weight ratios could be evolved.

Although the ECE need not be heavier than the ICE of today, it seems certain that it will always be somewhat large. Space requirements are dictated to a major extent by the heat-transfer apparatus, namely the boiler and condenser. Hopes for reducing the size of these components hinge largely on 2 considerations: increasing the unit effectiveness of the heat transfer process and raising the efficiency of the system in converting heat energy into useful work. An encouraging trend is shown in Figure 5.

Fuel Consumption

When tested under ideal conditions, engines based on Otto or diesel cycles almost invariably show a maximum attainable thermal efficiency higher than that of vehicular Rankine engines. This should not inhibit inquiry into the really pertinent questions: How do well-designed systems compare under actual conditions of vehicular operation? What undeveloped potential remains for each of the candidate systems?

Regarding the first question, a modern gasoline automobile engine, under ideal test conditions, can attain a thermal efficiency of 25 to 30 percent. The internal-combustion-powered automobile as a system, however, may have a vehicular thermal efficiency of only 10 to 12 percent in an actual urban driving cycle (10). Inefficiencies are attributed to the transmission, to engine idling, and to poor part-load fuel economy.

Regarding the second question, none of the power system candidates has reached its ultimate potential in terms of efficiency. The ECE, even with its sporadic and undernourished growth, has already passed the following significant mileposts (the thermal efficiency is the estimated heat overall thermal efficiency based on net shaft output):

<u>Period</u>	<u>Examples</u>	<u>Thermal Efficiency (percent)</u>
1900	Steam carriages, Stanley and Locomobile	5
1907-1910	Steam cars, White	12
1920-1950	Doble and Besler	15
1950-1960	Experimental steam systems, McCulloch and Williams	18
1966	Developmental Stirling cycle engines, General Motors model CPU-3 (13)	21 to 27

The thermal efficiency of any heat engine is strongly influenced by the maximum cyclic temperature. Gas turbine developments in recent years serve as an excellent example of evolution beyond original expectations. By 1971, developmental gas turbines for military vehicles were being operated with gas temperatures of 2,180 F (11). Only 20 years earlier, limiting temperatures of 1,500 F seemed an almost insurmountable barrier.

For some years now, the automotive steam engine has been held to peak temperatures not exceeding 800 to 1,000 F. By and large, lack of developments in (or substitutes for) high-temperature valving, cylinder assemblies, and cylinder lubricants have been responsible for this state of affairs. Figure 6 shows the increase in thermal efficiency that could follow a rise in permissible steam temperatures.

There also remain good possibilities for bringing the efficiency of the actual cycle closer to that of the theoretical cycle. One of the ways is to reduce the parasitic load

of the power-plant auxiliaries, such as condenser fan, boiler feed pump, and combustion air blower.

A third realm of improvement involves the recovery of benefit from wasted low-grade heat. Regenerative heat exchangers can be used. There is also the possibility of saving fuel by the use of absorption air conditioning rather than mechanical refrigeration.

### Operational Characteristics

Steam engines (and also electric motors) can exert a high starting torque and, hence, can move a heavy load from rest without the benefit of clutch or multiratio transmission. They can also be made reversible and can provide a substantial braking or retarding effort if desired. Although the vehicles converted for the California Steam Bus Project all employ an available automatic transmission (to simplify the design of demonstration engines), ECE power plants of the future may well eliminate or simplify the requirements for transmissions. In any event, smooth and rapid acceleration is a decided advantage gained by ECE-powered vehicles.

### Emissions and Noise

It has yet to be determined just how clean the exhaust of an ECE can be. A reasonable argument can be made that an efficient ECE power plant with steady-state, carefully controlled combustion is potentially as clean as a fuel-burning engine ever can be. If this be true, then it seems preferable to obtain a clean exhaust by this fundamentally correct approach rather than to add corrective devices to the ICE.

More and more is being heard these days about noise pollution. Here again, the ECE is inherently advantageous, having a closed-cycle engine exhaust. The better steam automobiles of yesteryear were almost inaudible at around-town speeds. Tire and wind noises tend to become more dominant at highway speeds with any vehicle, however.

Our growing awareness of environmental intrusion includes the concept of heat pollution. Unfortunately, all heat engines—whether ICE, gas turbine, or ECE—must eject heat into their surroundings in order to function. More efficient engines and more efficient utilization of vehicles can help.

It is true that electric vehicles—drawing current from either a battery or a conductor—are extremely clean at their immediate location. However, they do depend on an engine, a nuclear reactor, or a power dam in someone else's neighborhood.

### Economics

The various alternative power systems must be judged in the ever-changing arena of economics. Not surprisingly, it is believed that most substitutes for the ICE will involve a higher first cost, particularly if extensive retooling and other initiation costs are to be amortized. However, on the basis of total costs over the life of a vehicle, the ECE might be favored because of possibly lower maintenance costs (12), particularly if the competing ICE is burdened by emission control equipment requiring frequent attention.

## PROSPECTS FOR APPLICATION

It would be tragically premature to conclude that the ECE cannot be competitive merely because it became outmoded under earlier forms and conditions. There is ample evidence that many desired attributes are potentially available in the ECE—including quietness, cleanliness, and great flexibility in torque delivery. There is a need for continuing careful studies regarding possible economic advantages in the long term. Such studies must include the benefits and disutility costs of the alternatives to society as a whole, in addition to the direct impact on supplier and user. Difficult technical problems are being identified, principally connected with raising the thermal efficiency of small Rankine cycle systems while at the same time keeping the mechanism simple.

If applications do become widespread, they are likely to appear first in heavy-duty, stop-and-go fleet operations. Here, the ECE might show some of its advantages under

conditions that have always been difficult for the ICE. Smaller, urban fleet vehicles such as taxicabs and delivery trucks might be subsequent candidates.

The future of the ECE for constant high-speed, high-power applications such as long-haul trucking is less distinct, unless the full-load fuel economy can approach that of the diesel. Perhaps the gas turbine will eventually fit here, although the fuel consumption for truck turbines has to date been about as high as for present experimental steam engines.

Will the ECE drive private automobiles of the future? The writer offers the opinion that it could do so within a decade if it were merely a matter of developing the technology. Physical scaling considerations (such as condenser frontal area available versus power requirements) seem to favor a small-to-medium-sized vehicle with a modest power level (say, around 100 hp). Whether it will do so involves matters of resolve and sense of priorities within our society.

The writer is optimistic that the more general goal will be reached: The steam engine now seems destined either to be a stepping-stone to the clean engine of the future or to become the standard by which the emissions of future systems are to be judged.

#### ACKNOWLEDGMENT

A major portion of this report is based on results from the California Steam Bus Project, sponsored by the California State Assembly with a grant from the Urban Mass Transportation Administration of the U. S. Department of Transportation.

#### REFERENCES

1. Automobile Steam Engine and Other External Combustion Engines. Hearings before the Senate Committees on Commerce and Public Works, May 27-28, 1968, U. S. Govt. Printing Office, Washington, D. C., Serial 90-82, 1968.
2. Ayres, R. U., and McKenna, R. P. Alternatives to the Internal Combustion Engine. Johns Hopkins Univ. Press, 1972.
3. Morgan, D. T., and Raymond, R. J. Conceptual Design, Rankine-Cycle Power System With Organic Working Fluid and Reciprocating Engine for Passenger Vehicles. Thermo Electron Corp., Waltham, Mass., Rept. TE4121-133-70, June 1970.
4. Burkland, C. V., Lee, W. B., Bahn, G., and Carlson, R. Study of Continuous Flow Combustion Systems for External Combustion Vehicle Powerplants. Marquardt Corp., Van Nuys, Calif., Final Rept. CPA 22-69-128, June 1970.
5. Steam Bus Newsletter. California State Assembly, Sacramento.
6. Renner, R. A. California Steam Bus Project: A Midterm Review. ASCE, New York Preprint 1444, 1971.
7. Walton, J. N. Doble Steam Cars, Buses, Lorries, and Railcars. Light Steam Power, Isle of Man, Great Britain, 1965.
8. California Exhaust Emission Standards, Test and Approval Procedures for Diesel Engines in 1973 and Subsequent Model Year Vehicles Over 6,001 Pounds Gross Vehicle Weight. California Air Resources Board, 1971.
9. Dooley, J. L., and Bell, A. F. Description of a Modern Automotive Steam Powerplant. Society of Automotive Engineers, Los Angeles Section, Paper S338, 1962.
10. Smith, F. B., Jr., Meyer, W. A. P., and Ayres, R. U. A Statistical Approach to Describing Vehicular Driving Cycles. Society of Automotive Engineers, Paper 690212, 1969.
11. Engel, G., and Anderson, W. D. Compactness of Ground Turbine Depends on Integral Recuperator. SAE Journal, Vol. 79, No. 8, Aug. 1971.
12. Ayres, R. U., and Renner, R. A. Automotive Emission Control: Alternatives to the Internal Combustion Engine. Paper presented to the Air Pollution Control Association, West Coast Section, San Francisco, Oct. 8-9, 1970.
13. Agarwal, P. D., Mooney, R. J., and Toepel, R. R. Stir-Lec I, A Stirling Electric Hybrid Car. Society of Automotive Engineers, Paper 690074, 1969.



# DEFORMABLE MESH MOVING BELT AS AN ACCELERATING-DECELERATING DEVICE

Robert U. Ayres, International Research and Technology Corporation, Washington, D.C.;  
and  
Robert Malone, Pratt Institute, Brooklyn

●ONE OF the most vexing sociotechnological problems of today is that of public transportation, especially in the densely populated centers of major cities and at major transportation termini such as airports. The class of systems that seems to offer the greatest promise for filling this gap encompasses a variety of continuously accessible, continuously moving systems. The people conveyor idea is hardly new; it has been proposed many times in the past (1, 2, 3, 4). However, the key to practical embodiment of the system lies in the method used for getting people on and off the moving element. The speeds of the entry or exit ramps, and the conveyor belt itself, must be matched as closely as possible at the point of transfer. Yet, because the conveyor is to be used by people of all ages and physical conditions, the accelerations and decelerations must be effected smoothly and with as nearly absolute safety as possible. Past proposals usually have entailed a pair of adjacent parallel moving platforms, one with a slightly higher speed than the other, or a car running slowly along a track for loading and unloading, after which it accelerates to a higher speed between stations. Either method implies a considerable amount of mechanical complexity, and, of course, at each speed-change interface there are opportunities for mechanical breakdowns or accidents.

## PRINCIPLES OF OPERATION

An ideal entry-exit technique should achieve the necessary speed change smoothly and gradually, preferably with no sharp stepwise discontinuities at all. Although it would be very difficult to eliminate all such discontinuities completely, it is possible via the technique described here to achieve a reasonable final speed (8 to 12 mph) smoothly with only a single velocity-interface point involving a discrete speed change of 1.5 to 2.5 mph in the forward direction only (as with an escalator).

The problem of achieving effective acceleration is essentially to simulate, through mechanical means, the flow of a fluid. If a stream is forced through a narrow constriction, the speed of the flow increases, and vice versa; in aerodynamics this is the well-known Bernoulli effect. One simple means of accomplishing this speed-constriction trade-off in 2 dimensions is by means of a strip of a mesh, constructed like a fish net (5). The unit cells of this mesh are roughly parallelepipeds whose sides are inextensible (i. e., not stretchable) but bendable and whose joints (or vertices) are flexible. In short, the mesh can be distorted by extension along one axis and simultaneous contraction along an orthogonal one, as shown in Figure 1. If a belt constructed in this fashion is forced through a funnel-shaped constriction, the gradual narrowing and elongation of each cell along the line of motion will gradually increase the speed of anything riding on its surface. Thus, where the belt is wider it moves more slowly, and where it is narrower it moves more rapidly: the ratio of cell lengths along the direction of motion is equal to the ratio of speeds.

$$V_1/V_2 = \ell_1/\ell_2 = \sin \theta_1/\sin \theta_2$$

For a parallelogram mesh, the ratio of widths is given by the ratio of cosines.

$$W_1/W_2 = \cos \theta_1 / \cos \theta_2$$

However, in the case of the hexagonal mesh, we again have

$$V_1/V_2 = \ell_1/\ell_2 = \sin \theta_1 / \sin \theta_2$$

while

$$W_1/W_2 = (1 + \cos \theta_1)/(1 + \cos \theta_2) = [1 + \cos \sin^{-1}(\ell_{1/a})]/[1 + \cos \sin^{-1}(\ell_{2/a})]$$

For small values of  $\theta_1$  and  $\theta_2$ , it can be shown that the ratio of speeds may be quite large with only a slight change of width. For example, suppose  $\theta_1 = 0.02 \pi$  and  $\theta_2 = 0.10 \pi$ . Then,

$$\sin \theta_1 / \sin \theta_2 \cong 1/5$$

whereas

$$\cos \theta_1 / \cos \theta_2 = 1 - 0.002/1 - 0.05 \cong 1.05$$

and

$$(1 + \cos \theta_1)/(1 + \cos \theta_2) \cong (1 + 1 - 0.002)/(1 + 1 - 0.05) \cong 1.025$$

Thus, a 5:1 speed change requires only a 5 percent change in belt width for a quadrilateral mesh and a 2.5 percent change in belt width for the hexagon mesh. For larger values of  $\theta_1$  and  $\theta_2$ , however, arbitrarily great lateral distortions can be introduced in the quadrilateral case, but the hexagonal mesh can never increase (or decrease) in width by more than a factor of 2.

When the speed is maximum (in practice, perhaps 8 to 12 mph), the accelerating-decelerating strip can be made to run immediately adjacent to, or even on top of, a continuously moving (main) beltway. Not only is the interface easy to control but also it is possible to ensure a zero velocity differential across it; thus, the acceleration from walking speed to that of the belt can be made with almost complete smoothness after the initial entry (which would be similar to a conventional escalator). The exit procedure is, of course, essentially the same procedure in reverse. Two configurations in which a single variable-width belt serves both purposes are shown in Figure 2.

The entry-exit ramp strip, of course, is returned to its starting point in a continuous belt fashion, either underground or, alternatively, via a loop underneath the main conveyor. Exits and points of entry and of egress would normally be paired, possibly as shown in Figure 2. For shorter point-to-point links, however, the variable-width beltway might function as a self-contained relatively high-speed people-mover system in itself, with its own built-in accelerating and decelerating mechanisms at each end. Note that either the quadrilateral or hexagonal meshes are capable of lateral curvatures; i. e., they can turn corners.

The continuous velocity-changing strip described above can, in principle, be cascaded if it is found that a single stage is inadequate to achieve the desired final speed. However, there are practical upper limits for standing passengers imposed by the apparent wind caused by motion and the greater complexity of multiple-staging for entrance and egress.

It is also possible, at least in principle, to operate a deformable-mesh conveyor belt in a demand-activated mode. Thus, one can envision a closed loop normally moving at a constant uniform speed. Suppose, however, that such a loop consists of alternating regions of high and low density, similar to those shown in Figure 1. As viewed from a fixed external frame of reference both high and low density regions move at the same constant speed; whereas from a frame of reference fixed to the conveyor belt, the density variations (or density waves) appear to be stationary.

However, suppose a passenger wishes to enter (or exit) the system at some point along the loop. Then, following an appropriate signal to the control mechanism, one region of high density accelerates in the conveyor frame of reference and decelerates in the external frame of reference until it is stationary in the latter frame. A low-speed section is then momentarily available for the passenger to step onto (or off of). Subsequently, the sequence is reversed and the high-density region accelerates with respect to the external frame of reference and moves in the opposite direction along the moving belt until it regains its original position with respect to the rest of the loop. The sequence is shown schematically in Figure 3.

### THE MESH

Although it is not necessarily obvious from an examination of Figure 1, it can be shown easily that the desired speed-change function must be accompanied by some slight distortion of the structural members of the mesh. This distortion may take the form of either stretching or bending or both, but we shall assume inextensibility (no stretching) would be characteristic of most long-wearing structural materials.

It is obviously desirable that the joints or vertices connecting neighboring cells of the mesh should offer minimal resistance to angular flexing of the scissors type. A quadrilateral mesh (whose cells consist of equilateral parallelograms), such as the one shown in Figure 1, will have the necessary angular deformability, but this is not the only possible geometrical configuration with appropriate topological characteristics. Hexagons are probably more desirable because they involve less lateral distortion, as already pointed out.

It is apparent also that the mesh need not be homogeneous or uniform. It can, for instance, consist of a heavy-duty macromesh designed to carry the lateral and longitudinal stresses, plus a finer secondary micromesh designed to support a load-bearing surface (Fig. 4a). For the latter, there are a number of possible options, including a woven wire fabric, a solid mesh constructed of thin metal strips (Fig. 4b) having substantial rigidity in the vertical dimension while remaining flexible in the horizontal plane, or a tufted carpet of metallic or glass fiber yarn (Fig. 4c). Or, instead of tufted metal or glass fibers as such, short sections of thin fiber-stiffened plastic tubes might be utilized. The concept of a deformable carpet would be applicable to either a quadrilateral or hexagonal mesh.

As for the heavier tension-carrying elements of the macromesh, the members may consist of flexible rods, braided cable, metal strips, heavy wire, or any other material with high tensile strength and some stiffness (in regard to bending) but without rigidity. The vertices should have absolute rotational freedom as needed to ensure the requisite deformability of the mesh. The simplest form of hinge would probably be a simple rivet, perhaps utilizing a nylon grommet to minimize friction.

### PROPULSION

There are several possibilities for propulsion, but at this stage it seems likely that the external driving force would be applied via a series of spaced externally driven belts or rollers. Several variant approaches, such as a rotating Archimedes screw with an appropriately variable pitch or a pair of counter-rotating cones placed axially to the direction of motion, may also be used. In the future, however, it is expected that some sort of linear induction motor (LIM) would be the optimum means of propulsion.

### ANCILLARIES

Desirable ancillaries—mostly related to or considerations of safety or comfort—are as follows:

1. A hand grip or backrest or (preferably) both, traveling with the conveyor surface. An accordion-like handrail could be moved in phase with the feeder (mesh) belt by linking it directly to the main drive mechanism. The requisite degree of expansion or contraction or both could be provided by means of a segmented tubular structure.

Figure 1. Extension and contraction of mesh belt.

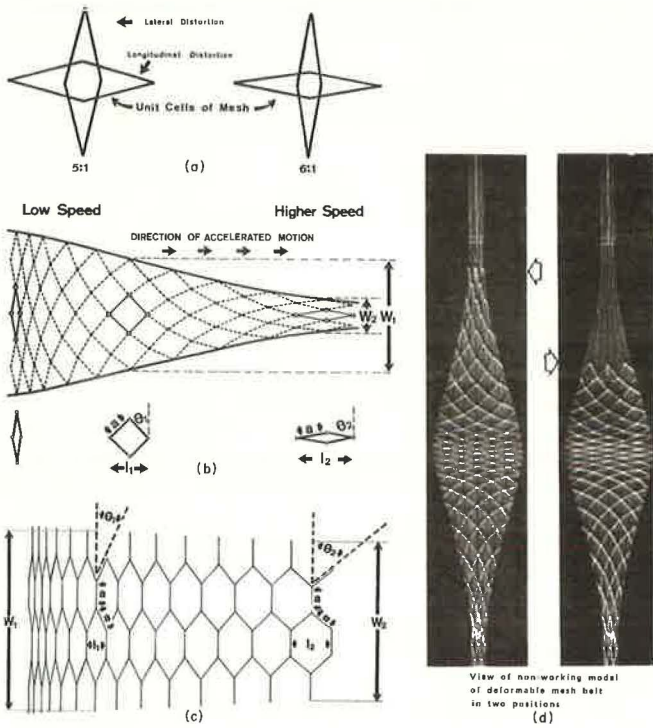

Figure 2. Mating of entry-exit ramps.

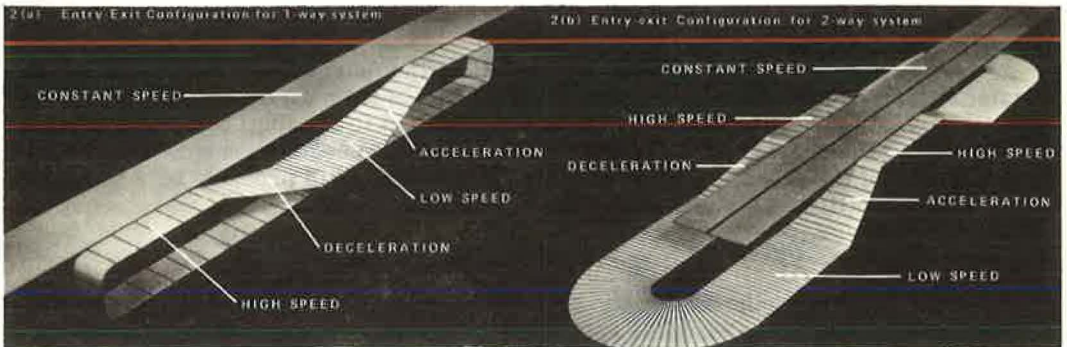
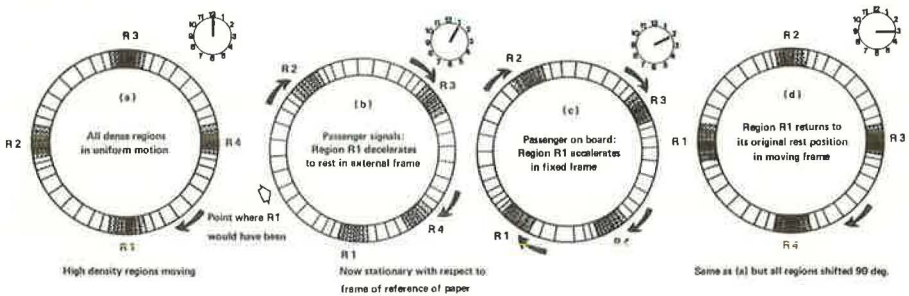

Figure 3. Sequence of acceleration and deceleration when passengers enter or exit.





It is not envisioned that passengers would sit down during the acceleration or deceleration phase (although seats would probably be provided on the main conveyor), but form-fitting backrests offering additional support and stability could be provided in the same way as handgrips.

2. A device to prevent loose items of clothing or baggage from being snagged at points where the moving conveyor passes under a stationary platform. For instance, a high pressure jet of compressed air might be forced through the moving mesh at such points to ensure that no article of clothing or personal property could possibly be caught and accidentally dragged under the edge of the stationary platform or between the feeder belt and the main conveyor (Fig. 5).

3. A system to discourage people from debarking onto the exit strip too close together so that there is no uncomfortable crowding during deceleration. Signs, flashing lights, and taped loud-speaker instructions could be used to stress the importance of this precaution. Properly spaced handgrips would be most effective in discouraging bunching at points of egress.

4. A suitable gate to permit one entrance-exit to be shut down and withdrawn from service for maintenance or other reasons without affecting the main conveyor system.

5. A suitable arrangement for surveillance and supervision, presumably via closed-circuit TV. An alarm system permitting passengers to call for assistance should also be considered.

6. Facilities for emergency entrance and exit (for guards, police, first aid, or maintenance) possibly via suitable slides or chutes, or possibly wheeled electric mini-cycles.

#### URBAN DESIGN IMPLICATIONS

The fact that either of the deformable mesh configurations is capable of curving and turning corners, in contrast to conventional conveyor belts that require a line-of-sight right-of-way, is of critical importance. Evidently, a curvilinear conveyor system would be extraordinarily flexible, accommodating itself easily to irregular terrain and existing structures. For instance, it is quite possible to envision a people mover utilizing the deformable mesh principle passing through individual buildings or even through a series of adjacent structures, and resulting in an internal arcade.

The implications of such a system for urban architecture and city planning are profound. The nature of the system permits it to be introduced on a small scale and expanded gradually, without the major upheavals that usually accompany a significant advance in transportation technology.

The advantages of the system fall into 2 major categories: scale and flexibility. The scale advantages are of several kinds. In the first place, the belt and its bed are the only hardware involved; there are no extra parts such as cars or cabs to be moved, stored, repaired, and so on. The only probable accessories might be a signal system and an automatic cleaning system. This creates a very low profile, adds almost nothing to the scene, and uses no additional real estate. Because the belt itself is like a sidewalk or hallway floor, the people or objects being moved are the only visible moving parts.

This obviously reduces not only the maintenance and design problems but also, perhaps most important, the energy problem. When the containers (cars, cabs, and so on) used by conventional systems are eliminated, most of the weight being moved is automatically eliminated as well. This reduces the energy requirements proportionately—an important ecological consideration. Moreover, in terms of the passengers' own immediate environment, both noise and fume emission are eliminated; by contrast with any existing mode of travel, this belt system would be both clean and silent, having nearly no pollutant side effects within the channel of movement.

The flexibility of the system makes possible another whole category of change in the urban environment. The variable speeds and rhythms along the system create an adaptability to all scales. The system and its controls do not get more cumbersome as they get larger; they just ramify like a tree, still completely integrated. This makes it possible to design and install the system at any scale.

The system can also be made responsive to automatic electronic control (programmed automation) and is particularly adaptable to this type of control because, no matter how extensive, it is organically one system. There is great compatibility between a possible control system and the nature of the belt system itself, for it is completely integrated and flexible virtually down to the cellular level. The system is not strained by additional loops and can operate at any scale, large or small, with no loss of efficiency.

From a human-factor point of view, the system can be made totally responsive: Passenger stops can be created at command, on the principle of the push-button walk lights now in use. Moreover, the belt system can interpenetrate and connect both outdoor and indoor spaces. It would no longer be necessary to think of exterior and interior transportation as separate design problems. Clearly, this would open up city planning and architecture in the directions of multiple-level access and use of space and tend to reduce the problems of jamming and congestion designers now have to cope with at each point where the mode or direction of travel changes. If a belt system such as this is used, the direction could change in 3 dimensions without a change in mode having to be forced.

#### DESCRIPTION OF VARIFLEX MODEL

The variflex model exhibits in reduced scale a continuously moving surface that varies in speed (and density) as it moves around a closed circuit. The model consists of 4 major components: hexagonal mesh belt, support for the belt, speed-changing system, and drive motor.

The belt consists of aluminum strips bonded together to form a cellular matrix—when fully extended—similar to honeycomb. Unlike the latter, of course, the cells of the aluminum mesh remain flexible as long as the plastic limit of the material is not exceeded. The material is thin (0.002 in.) so that longitudinal extension by a factor of 5 still corresponds to a very small angular distortion and, consequently, a small change in belt width.

The support mechanism consists of a secondary fabric belt having a suede-like surface that interlocks with the cellular structure of the belt to maximize sliding resistance. All constant speed movement by the belt whether fast or slow is controlled by secondary belts.

Each transition zone between fast and slow sections of the loop requires a speed-changing mechanism. This is accomplished in the model by a pair of counter-rotating conical rollers that have axes of rotation nearly parallel to the direction of motion of the belt. The slight angle  $\phi$  between the cones and the belt produces a driving component in the direction of motion proportional to  $\sec \phi$ .

The drive consists of a  $\frac{1}{40}$ -hp, 110-volt motor connected to a sprocket and chain transmission (Fig. 6). The transmission drives a set of flexible shafts at speeds compatible with the requirements of the primary and secondary belts.

#### VARIFLEX MODEL SPECIFICATIONS

Specifications are as follows:

- Model: 24 by 36 by 60 in. irregular
- Belt surface:  $4\frac{1}{2}$  by 60 in. ( $4\frac{1}{2}$  by 122 endless)
- Speed ratio: 5 to 1 (2.0 in./sec to 0.4 in./sec)
- Drive:  $\frac{1}{40}$ -hp, 110-volt motor
- Transmission: chain and sprocket with flexible shafts to belt surface carrier
- Acceleration: 0.122 in./sec<sup>2</sup> each direction

The potential impact of a pedestrian-oriented people mover on an archetypal urban activity center—downtown Lower Manhattan—has been investigated in a study sponsored by the U. S. Department of Housing and Urban Development (6).

For purposes of analysis, a moving sidewalk was "implanted" (hypothetically) along Broadway, Water Street, and Fulton Street to form a loop around the Lower Manhattan Financial District, as shown in Figure 7. The conveyor was assumed to be free of

Figure 4. Alternative mesh configurations.

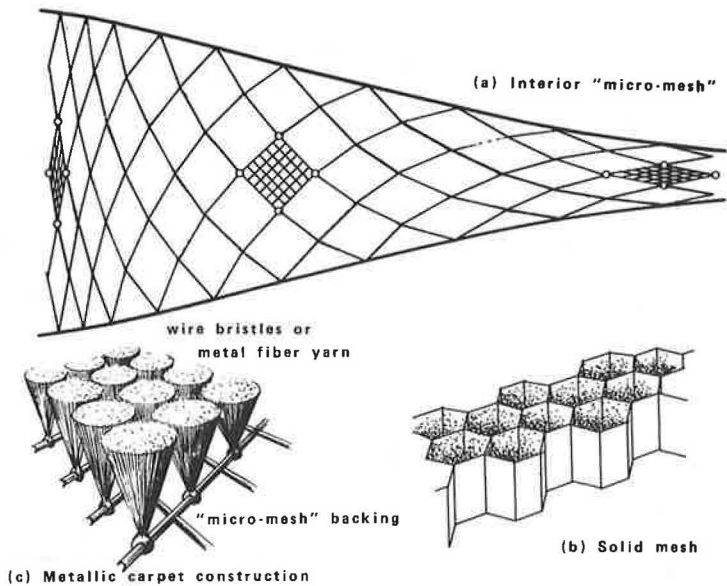

Figure 5. Device to prevent material from being caught at stationary platforms.

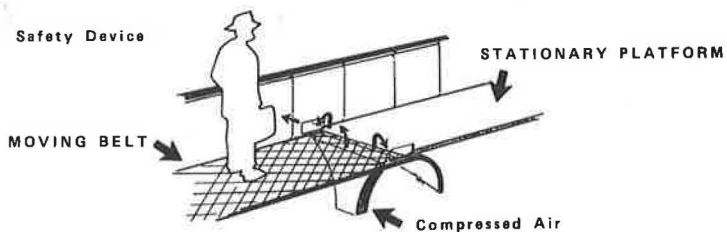
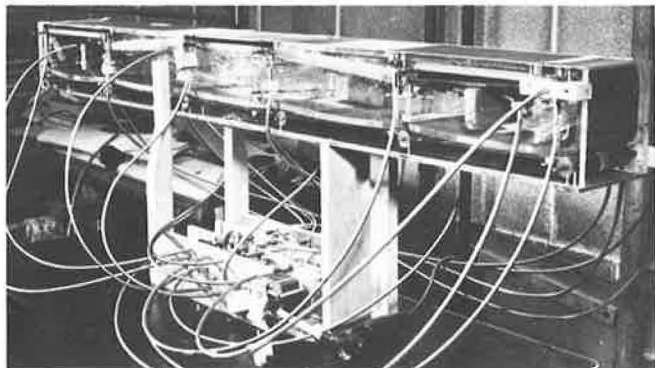
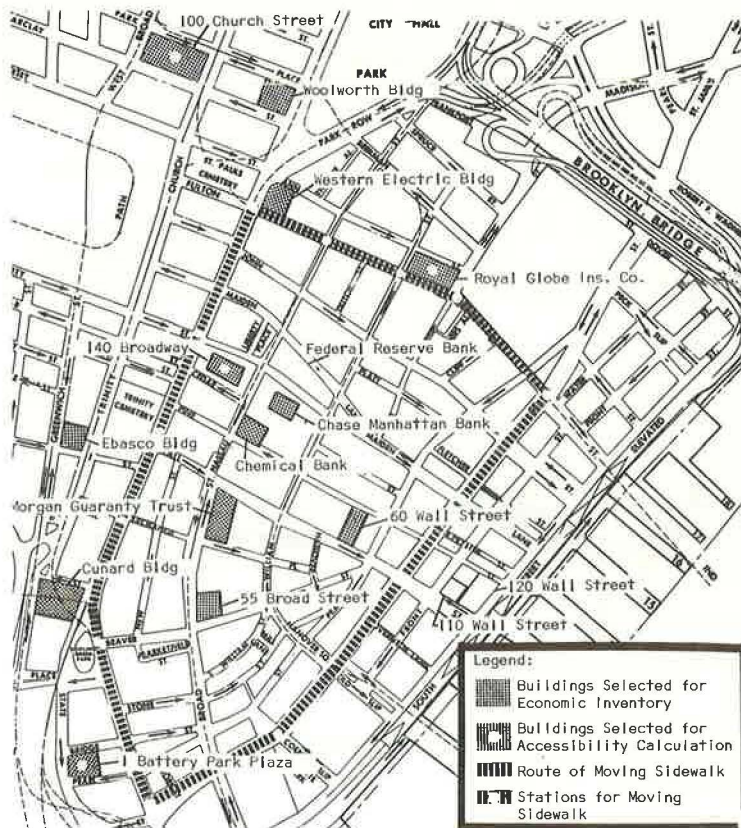

Figure 6. Transmission drive of working model.



**Figure 7. Implanted moving sidewalk in Lower Manhattan.**



**Figure 8. Changes in sector accessibility due to moving sidewalk.**

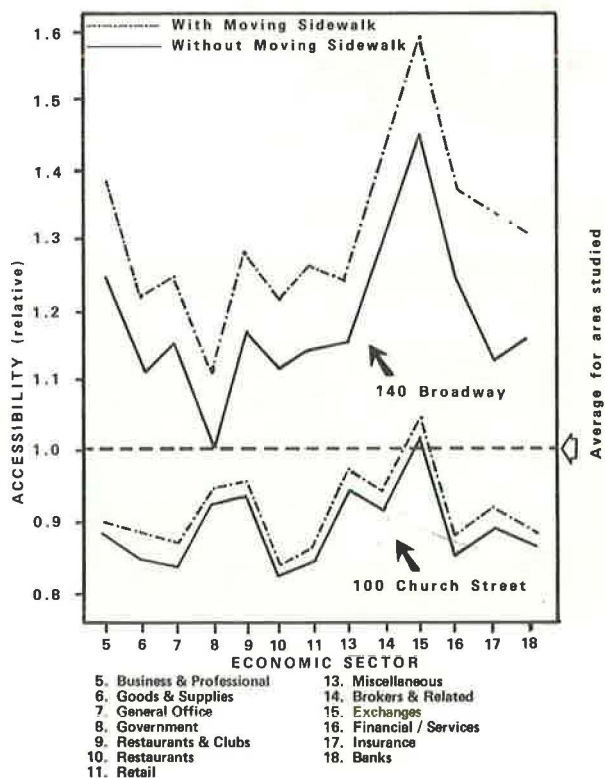



charge, to move at 8 mph, to be covered against the elements, and to be elevated above street level. The system could be boarded at each stop for transportation in both directions and did not require slowdowns at intermediate stations. It was assumed that suitable means for accelerating onto and decelerating off of the conveyor were available.

The principal effect of this implantation was to alter the accessibilities of various locations in the immediate area, relative to their accessibilities without the conveyor system. Accessibility for a point location is defined as the sum of all destinations reachable from that point by all modes of transportation (including walking), weighted inversely by a measure of the difficulty of reaching each destination (a function of cost, time, and stress involved in making the trip), multiplied by the intrinsic frequency of interaction between a given activity located at the origin and a given activity at the destination, and weighted by the number of people engaged in each economic activity at each point. To compute this index quantitatively requires that specific data be obtained on the geographical possibilities for transportation, detailed characteristics of the transportation network, optimum routes and modes linking all pairs of points, distribution of employment by activity and by location, and probability of interaction (i. e., trip-making) among different economic activities. Such a data bank has been collected for downtown Lower Manhattan, and the necessary calculations were carried out (6).

A comparison of sectoral accessibilities with and without the conveyor system is shown in Figure 8 for 2 building locations, 140 Broadway and 100 Church Street. The accessibility of 140 Broadway, already much better than average, is markedly improved further by the new transportation system, whereas 100 Church Street, not very accessible to begin with, is not much benefited by the conveyor belt, which, at its point of closest approach, is 3 blocks away. The effect of the implantation is to increase accessibility by a minimum of 1 percent to a maximum of 13 percent, depending on sector and location.

As far as the economic impact is concerned, a change in accessibility implies an increased demand for space at the same rent or—with space constrained to remain the same in the short run—an increased equilibrium rental value.

The data so far obtained support the conclusion, tentative at this time, that the equilibrium demand for space (with rents held fixed) is a very strong function of accessibility. Thus, a 5 percent increase in accessibility would seem to result in close to 50 percent more demand for space at the same price. Because the accessibility change is sector dependent, external changes in transportation, land use, or improvement can cause shifts in demand for space by different sectors and can engender new patterns for space use and employment skills.

#### REFERENCES

1. Richards, B. *New Movement in Cities*. Sudio Vista, London, and Reinhold, New York.
2. Tough, J. M. *A Feasibility Study of the Utilization of Passenger Conveyors as a Form of Communal Transport*. Leeds Univ., United Kingdom, MS thesis, 1968.
3. Ayres, R. U., and McKenna, R. P. *The Range of Technological Possibilities: Non-Vehicular Modes of Transportation*. International Research and Technology Corp., Washington, D. C., IRT-N-31/1, Aug. 1969.
4. *New Technology and Transportation, 1970-1990*. Eurofinance, Paris, 1971.
5. Ayres, R. U., and McKenna, R. P. U. S. Patent.
6. *Study of Major Urban Activity Circulation Systems and Their Impact on Congested Areas*. International Research and Technology Corp., Washington, D. C., IRT-R-29, June 9, 1970.

## SPONSORSHIP OF THIS RECORD

GROUP 1—TRANSPORTATION SYSTEMS PLANNING AND ADMINISTRATION  
Charles V. Wootan, Texas A&M University, chairman

Committee on New Transportation Systems and Technology

Leon M. Cole, University of Texas at Austin, chairman

William H. Avery, Robert U. Ayres, George J. Bacalis, Eugene T. Canty, Arthur A. Davis, Donn Fichter, Donald Friedman, William F. Hamilton, II, M. D. Harmelink, Kenneth W. Heathington, William S. Jewell, Harold W. Merritt, Theodore F. Morf, Robert A. Olmsted, C. Kenneth Orski, Herbert A. Richardson, Daniel Roos, Albert J. Sobey, Charles E. Taylor, J. William Vigrass, Lucius Walker, Jr., Foster L. Weldon

James A. Scott, Highway Research Board staff