

NCHRP Report 381

**Report on the 1995 Scanning Review of
European Bridge Structures**

Denmark · Germany · Switzerland · France · United Kingdom

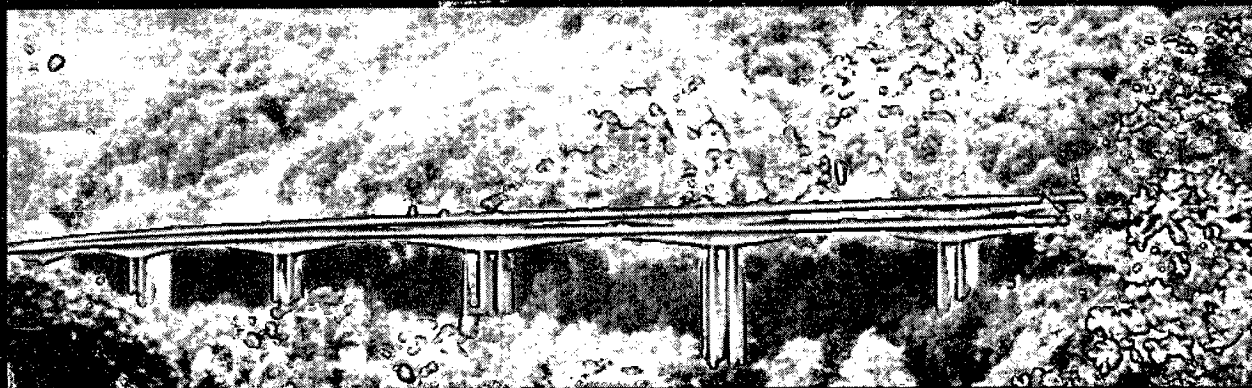

AASHTO · FHWA · ACEC · AISC · ARTBA · AGC · PCA

Transportation Research Board
National Research Council

TRANSPORTATION RESEARCH BOARD EXECUTIVE COMMITTEE 1996

OFFICERS

Chair: James W. VAN Loben Sels, Director, California Department of Transportation

Vice Chair: David N. Wormley, Dean of Engineering, Pennsylvania State University

Executive Director: Robert E. Skinner, Jr., Transportation Research Board

MEMBERS

EDWARD H. ARNOLD, Chair and President, Arnold Industries, Lebanon, PA

SHARON D. BANKS, General Manager, AC Transit, Oakland, CA

BRIAN J. L. BERRY, Lloyd Viel Berkner Regental Professor & Chair, Bruton Center for Development Studies, University of Texas at Dallas

LILLIAN C. BORRONE, Director, Port Department, The Port Authority of New York and New Jersey (Past Chair, 1995)

DWIGHT M. BOWER, Director, Idaho Department of Transportation

JOHN E. BREEN, The Nasser I. Al-Rashid Chair in Civil Engineering, The University of Texas at Austin

WILLIAM F. BUNDY, Director, Rhode Island Department of Transportation

DAVID BURWELL, President, Rails-to-Trails Conservancy

E. DEAN CARLSON, Secretary, Kansas Department of Transportation

A. RAY CHAMBERLAIN, Vice President, Freight Policy, American Trucking Associations, Inc. (Past Chair, 1993)

RAY W. CLOUGH, Nishkian Professor of Structural Engineering Emeritus, University of California, Berkeley

JAMES N. DENN, Commissioner, Minnesota Department of Transportation

JAMES C. DeLONG, Director of Aviation, Denver International Airport, Denver, Colorado

DENNIS J. FITZGERALD, Executive Director, Capital District Transportation Authority, Albany, NY

DAVID R. GOODE, Chair, President and CEO, Norfolk Southern Corporation, Norfolk, VA

DELON HAMPTON, Chair and CEO, Delon Hampton & Associates, Washington, DC

LESTER A. HOEL, Hamilton Professor, Civil Engineering, University of Virginia

JAMES L. LAMMIE, Director, Parsons Brinckerhoff, Inc., New York, NY

ROBERT E. MARTINEZ, Secretary of Transportation, Virginia Department of Transportation

CHARLES P. O'LEARY, JR., Commissioner, New Hampshire Department of Transportation

CRAIG E. PHILIP, President, Ingram Barge Co., Nashville, TN

WAYNE SHACKELFORD, Commissioner, Georgia Department of Transportation

JOSEPH M. SUSSMAN, JR East Professor, Civil and Environmental Engineering, MIT (Past Chair, 1994)

MARTIN WACHS, Director, Institute of Transportation Studies, University of California, Los Angeles

MIKE ACOTT, President, National Asphalt Pavement Association (ex officio)

ROY A. ALLEN, Vice President, Research and Test Department, Association of American Railroads (ex officio)

ANDREW H. CARD, JR., President and CEO, American Automobile Manufacturers Association (ex officio)

THOMAS J. DONOHUE, President and CEO, American Trucking Associations (ex officio)

FRANCIS B. FRANCOIS, Executive Director, American Association of State Highway and Transportation Officials (ex officio)

DAVID GARDINER, Assistant Administrator, Environmental Protection Agency (ex officio)

JACK R. GILSTRAP, Executive Vice President, American Public Transit Association (ex officio)

ALBERT J. HERBERGER, Maritime Administrator, U.S. Department of Transportation (ex officio)

DAVID R. HINSON, Federal Aviation Administrator, U.S. Department of Transportation (ex officio)

T. R. LAKSHMANAN, Transportation Statistics Director, U.S. Department of Transportation (ex officio)

GORDON J. LINTON, Federal Transit Administrator, U.S. Department of Transportation (ex officio)

RICARDO MARTINEZ, National Highway Traffic Safety Administrator, U.S. Department of Transportation (ex officio)

JOLENE M. MOLITORIS, Federal Railroad Administrator, U.S. Department of Transportation (ex officio)

DHARMENDRA K. (DAVE) SHARMA, Research and Special Programs Administrator, U.S. Department of Transportation (ex officio)

RODNEY E. SLATER, Federal Highway Administrator, U.S. Department of Transportation (ex officio)

ARTHUR E. WILLIAMS, Chief of Engineers and Commander, U.S. Army Corps of Engineers (ex officio)

NATIONAL COOPERATIVE HIGHWAY RESEARCH PROGRAM

Transportation Research Board Executive Committee Subcommittee for NCHRP

JAMES W. VAN LOBEN SELS, California Department of Transportation, (Chair)

LILLIAN C. BORRONE, Port Authority of New York and New Jersey,

FRANCIS B. FRANCOIS, American Association of State Highway and
Transportation Officials

Field of Special Projects Area of Special Projects Project Panel SP20-36

BYRON C. BLASCHKE, Texas A & M University at College Station
(Chair)

JOHN D. CUTRELL, Keedysville, MD

ROBERT A. FORD, Federal Highway Administration

FRANCIS B. FRANCOIS, AASHTO

MERRITT LINZIE, Minnesota Department of Transportation

MARTIN PIETZ, Washington Department of Transportation

LESTER A. HOEL, University of Virginia

ROBERT E. SKINNER, JR., Transportation Research Board

RODNEY E. SLATER, Federal Highway Administration

DAVID N. WORMLEY, Pennsylvania State University

EUGENE F. REILLY, Metuchen, NJ

RICHARD B. ROBERTSON, International Road Federation

T. PETER RUANE, ARTBA

C. MICHAEL WALTON, University of Texas at Austin

ROBERT L. WHITE, Consoer, Townsend, Envirodyne Engineers, Inc., Charlotte, NC

JIM WENTWORTH, FHWA Liaison Representative

ROBERT E. SPICHER, TRB Liaison Representative

Program Staff

ROBERT J. REILLY, Director, Cooperative Research Programs

CRAWFORD F. JENCKS, Manager, NCHRP

LLOYD R. CROWTHER, Senior Program Officer

B. RAY DERR, Senior Program Officer

AMIR N. HANNA, Senior Program Officer

RONALD D. McCREADY, Senior Program Officer

KENNETH S. OPIELA, Senior Program Officer

SCOTT A. SABOL, Senior Program Officer

EILEEN P. DELANEY, Editor

KAMI CABRAL, Assistant Editor

HILARY FREER, Assistant Editor

Report 381

Report on the 1995 Scanning Review of European Bridge Structures

Subject Areas

Materials and Construction
Bridges, Other Structures, and Hydraulics and Hydrology

Research Sponsored by the American Association of State
Highway and Transportation Officials in Cooperation with the
Federal Highway Administration

TRANSPORTATION RESEARCH BOARD
NATIONAL RESEARCH COUNCIL

NATIONAL ACADEMY PRESS
Washington, D.C. 1996

NATIONAL COOPERATIVE HIGHWAY RESEARCH PROGRAM

Systematic, well-designed research provides the most effective approach to the solution of many problems facing highway administrators and engineers. Often, highway problems are of local interest and can best be studied by highway departments individually or in cooperation with their state universities and others. However, the accelerating growth of highway transportation develops increasingly complex problems of wide interest to highway authorities. These problems are best studied through a coordinated program of cooperative research.

In recognition of these needs, the highway administrators of the American Association of State Highway and Transportation Officials initiated in 1962 an objective national highway research program employing modern scientific techniques. This program is supported on a continuing basis by funds from participating member states of the Association and it receives the full cooperation and support of the Federal Highway Administration, United States Department of Transportation.

The Transportation Research Board of the National Research Council was requested by the Association to administer the research program because of the Board's recognized objectivity and understanding of modern research practices. The Board is uniquely suited for this purpose as it maintains an extensive committee structure from which authorities on any highway transportation subject may be drawn; it possesses avenues of communications and cooperation with federal, state and local governmental agencies, universities, and industry; its relationship to the National Research Council is an insurance of objectivity; it maintains a full-time research correlation staff of specialists in highway transportation matters to bring the findings of research directly to those who are in a position to use them.

The program is developed on the basis of research needs identified by chief administrators of the highway and transportation departments and by committees of AASHTO. Each year, specific areas of research needs to be included in the program are proposed to the National Research Council and the Board by the American Association of State Highway and Transportation Officials. Research projects to fulfill these needs are defined by the Board, and qualified research agencies are selected from those that have submitted proposals. Administration and surveillance of research contracts are the responsibilities of the National Research Council and the Transportation Research Board.

The needs for highway research are many, and the National Cooperative Highway Research Program can make significant contributions to the solution of highway transportation problems of mutual concern to many responsible groups. The program, however, is intended to complement rather than to substitute for or duplicate other highway research programs.

Note: The Transportation Research Board, the National Research Council, the Federal Highway Administration, the American Association of State Highway and Transportation Officials, and the individual states participating in the National Cooperative Highway Research Program do not endorse products or manufacturers. Trade or manufacturers' names appear herein solely because they are considered essential to the object of this report.

NCHRP REPORT 381

Project 20-36 FY '94

ISSN 0077-5614

ISBN 0-309-05717-5

L. C. Catalog Card No. 96-60989

Price \$18.00

NOTICE

The project that is the subject of this report was a part of the National Cooperative Highway Research Program conducted by the Transportation Research Board with the approval of the Governing Board of the National Research Council. Such approval reflects the Governing Board's judgment that the program concerned is of national importance and appropriate with respect to both the purposes and resources of the National Research Council.

The members of the technical committee selected to monitor this project and to review this report were chosen for recognized scholarly competence and with due consideration for the balance of disciplines appropriate to the project. The opinions and conclusions expressed or implied are those of the research agency that performed the research, and, while they have been accepted as appropriate by the technical committee, they are not necessarily those of the Transportation Research Board, the National Research Council, the American Association of State Highway and Transportation Officials, or the Federal Highway Administration, U.S. Department of Transportation.

Each report is reviewed and accepted for publication by the technical committee according to procedures established and monitored by the Transportation Research Board Executive Committee and the Governing Board of the National Research Council.

Published reports of the

NATIONAL COOPERATIVE HIGHWAY RESEARCH PROGRAM

are available from:

Transportation Research Board
National Research Council
2101 Constitution Avenue, N.W.
Washington, D.C. 20418

Printed in the United States of America

FOREWORD

*By Staff
Transportation Research
Board*

The report contains the findings of a scanning review conducted to capture a broad overview of bridge technology in Europe with the goal of identifying technologies and practices that merit further consideration. The report includes observations made by the scanning review members and lists recommendations that merit consideration by public and private agencies. The contents of the report will be of interest to those involved in planning, designing, and constructing bridge projects.

Over the past two decades, bridge technology in Europe and North America has grown similar. However, to review European bridge practices and identify some for potential domestic application, a European Bridge Structures Technology Scanning Review was conducted from June 18 to July 1, 1995. In addition to personnel from the FHWA and AASHTO member departments, individuals from the private sector and academia participated in the review.

The report, prepared collectively by members of the review team, documents the observations made in five European countries—Denmark, Germany, Switzerland, France, and the United Kingdom. It reviews European bridge practices in the areas of policy, administration, and management; design philosophies and methods; materials; production and fabrication; bridge management systems; and maintenance. In addition, the report discusses the potential technical, economic, and environmental advantages of European practices. Finally, the report provides 18 recommendations that merit consideration by public and private agencies to increase service life, reduce maintenance, and improve the aesthetics of bridge structures.

CONTENTS

1	SUMMARY
3	CHAPTER 1 Introduction
	Purpose, 3
	Sponsoring Organizations, 3
	Panel Members, 3
	Country Summaries, 4
	Denmark, 4
	Germany, 4
	Switzerland, 4
	France, 9
	The United Kingdom, 11
13	CHAPTER 2 Observations, Discussions, and Recommendations
	Policy, Administration, and Management, 13
	Shared Risk and Responsibility, 13
	Public Interest in Bridges, 14
	Warranties and Liabilities, 14
	Funding Directions, 14
	Aesthetic Concerns, 15
	Initial Cost and Life-Cycle Cost, 15
	Design-Delivery and Project-Delivery Systems, 16
	Research Programs, 17
	Design Philosophies, Concepts, Methodologies, and Specifications, 17
	Unconventional Structural Systems, 17
	Construction Materials, 17
	Use of Deck Overhangs and Beam Elements, 18
	Partial Prestressing, 18
	Bridge Rating and Eurocode Development, 18
	Jointless Construction, 18
	Materials and Systems, 18
	Concrete Materials and Durability, 19
	Composite Materials, 19
	Waterproofing, 19
	Epoxy-Coated Reinforcement, 21
	Corrugated Steel Webs, 22
	Superstructure Enclosure Systems, 22
	Coating Systems, 22
	Grouted, Post-Tensioned Concrete, 23
	Bridge Railings, 23
	Production, Fabrication, and Erection Processes, 24
	Quality Control, 24
	Erection Methods, 24
	Thermo-Mechanical Process Control, 24
	Bridge Management Systems, Inspection, and Evaluation, 25
	Bridge Management Systems, 25
	Inspection Practices, 25
	Nondestructive Evaluation Devices, 25
	Maintenance Practices, 26
	Traffic Flow Considerations, 26
	Bridge Washing, 26
27	CHAPTER 3 Recommendations
	High-Priority Recommendations, 27
	Medium-Priority Recommendations, 27
28	APPENDIX A Panel Members
30	APPENDIX B Itinerary

ACKNOWLEDGMENTS

The sponsors thank their colleagues in Denmark, Germany, Switzerland, France, and the United Kingdom for sharing their time and experiences with the panel members.

The sponsors also thank the Transportation Technology Evaluation Center of Loyola College in Baltimore, Maryland, for providing travel arrangements and other coordination. The panel members thank, in particular, Mr. Joseph N. Conn and Mr. John O'Neill for their able assistance throughout Europe. The panel members also thank their sponsors for providing the opportunity to participate in this enriching endeavor.

Dr. Dennis R. Mertz, with the assistance of the other panel members, prepared the report. Mr. Ernst Petzold, in particular, provided a suggested structure for the report, which resulted in clear explanations of the panel members' recommendations relative to their observations. Mr. M.G. Patel, Mr. David M. Moskowitz, and Dr. John M. Kulicki provided photographs for the report. NCHRP Program Officer Dr. Amir N. Hanna deserves considerable appreciation for his contribution to the preparation of this report.

REPORT ON THE 1995 SCANNING REVIEW OF EUROPEAN BRIDGE STRUCTURES

SUMMARY

Over the past two decades, bridge technology in Europe and North America has grown more similar. Twenty years ago, when American bridge engineers informally visited Europe, they brought back with them cable-stayed and segmental prestressed-concrete bridge design and construction techniques, including a new bearing type—pot bearings. Since then, engineers in Europe and North America have shared information. Differences remain, but practices are converging. When the panel visited Denmark, Germany, Switzerland, France, and the United Kingdom, members found technology with slight, albeit intriguing, differences from their own—not the vastly differing technology of 20 years ago.

It is not clear whether the differences in bridge technology are technological or cultural; it is likely they are cultural; however, the bridge technology of Europe should not be dismissed as irrelevant to the United States. The differences in bridge technology noted do not reflect cultural differences in general society as much as cultural differences between the bridge communities of the United States and Europe. For example, the Europeans view existing bridges as an inheritance from their ancestors and new bridges are their generation's legacy to those who follow—bridges are an integral part of their culture.

European bridge engineers emphasize innovation, aesthetics, and durability so that the bridges they design and construct are a fitting legacy for their descendants. Further, they are committed to maintaining their bridges and those of past generations.

European society, which is less litigious than that of the United States, encourages innovation. The litigious nature of U.S. society cannot be changed easily and must be considered when determining the applicability of European bridge practices in the United States. Unfortunately, the Europeans see increasing litigation in their society.

The panel made numerous significant observations during their Technology Scanning Review of Denmark, Germany, Switzerland, France, and the United Kingdom. On the basis of these observations, the panel offers 18 recommendations to the U.S. bridge community; these recommendations are intended to improve innovation, durability, quality, maintenance, and aesthetics. The panel recommends the following:

- Conduct of a study to evaluate U.S. and European project-delivery systems;
- Investigation of European practices designed to emphasize quality, durability, and aesthetics during all stages of bridge engineering and construction, such as concrete mixes

designed for durability, thermo-mechanical process control for steel production, and innovative paint systems and metallizing;

- Adoption of practices to encourage the sharing of responsibility for “proof of concept”;
 - Conduct of a study to evaluate U.S. and European deck waterproofing systems;
 - Consideration of increased funding by bridge owners for routine maintenance;
 - Development by the AASHTO Highway Subcommittee on Bridges and Structures of rating specifications that reflect the latest design specifications;
 - Conduct of a study to reevaluate European-style contractor warranties;
 - Development of an informational package promoting public awareness of how bridge and highway investment benefits the United States;
 - Review and participation by the AASHTO Highway Subcommittee on Bridges and Structures in developing the Eurocode;
 - Sponsorship by the FHWA of projects demonstrating the use of under-deck superstructure enclosures to retard corrosion;
 - Sponsorship by the FHWA of projects demonstrating the use of three-dimensional space-frame superstructures;
 - Sponsorship by the FHWA of projects demonstrating the use of concrete form liners designed to enhance the near-surface durability;
 - Evaluation by the FHWA of procedures being developed in the United Kingdom for grouting longitudinally post-tensioned concrete bridges and, if warranted, preparation of a technical advisory to disseminate information on the United Kingdom’s experience.
 - Consideration by bridge owners of peer review for the design of major or unusual bridges;
 - Increased consideration by state departments of transportation (DOTs) and the FHWA of aesthetics;
 - Development of curriculum to enhance the teaching of design for durability and inclusion by the Accreditation Board for Engineering Technology of design for durability among the accreditation criteria;
 - Continued investigation of the use of corrugated steel webs; and
 - Preparation by the FHWA of a technical advisory recommending field testing to destruction of decommissioned bridges.
-

CHAPTER 1

INTRODUCTION

PURPOSE

The purpose of the European Bridge Structures Technology Scanning Review (conducted from June 18 to July 1, 1995) was to enable panel members to do the following:

- Review European bridge practice for potential domestic application in the following areas:
 - Policy, administration, and management;
 - Design philosophies, concepts, methodologies, and specifications;
 - Materials and systems;
 - Production, fabrication, and erection processes;
 - Bridge management systems, inspection, and evaluation; and
 - Maintenance practices;
- Evaluate European practices on the basis of the potential for the following:
 - Design and construction improvements;
 - Long service life;
 - Low life-cycle cost;
 - Ease and economy of maintenance;
 - Environmental acceptability; and
 - Success within the U.S. political, legal, and economic cultures; and
- Recommend appropriate actions to implement or further develop bridge engineering practices that may enhance the United States' highway system, productivity, and economic future.

The Technology Scanning Review was intended to capture a broad overview of bridge technology in Europe with the goal of identifying future more focused efforts, such as research projects, demonstration projects, or even future scanning reviews. It was specifically not the intent to focus on specific areas of technology identified prior to the trip to Europe, as past reviews have. As such, the panel was constituted so as to bring a broad range of expertise and experience to the review. Similarly, the itinerary of five countries in 2 weeks was developed so that the panel would interact with a range of hosts and other participants having a similar range of expertise and experience.

SPONSORING ORGANIZATIONS

The Technology Scanning Review of European Bridge Structures was conducted under the auspices of the FHWA's International Outreach Program and the AASHTO-sponsored NCHRP in cooperation with the American Consulting Engineers Council (ACEC), the American Institute of Steel Construction (AISC), the American Road and Transportation Builders Association (ARTBA), the Associated General Contractors of America (AGC), and the Portland Cement Association (PCA).

PANEL MEMBERS

The members of the panel, along with the agencies they represent, are as follows:

- Mr. James E. Siebels, panel Co-Chair, Colorado Department of Transportation, AASHTO
- Ms. Laurinda T. Bedingfield, Massachusetts Highway Department, AASHTO
- Mr. Donald J. Flemming, Minnesota Department of Transportation, AASHTO
- Mr. David J. Hensing, AASHTO
- Mr. Charles Lewis, Georgia Department of Transportation, AASHTO
- Mr. M. G. Patel, Pennsylvania Department of Transportation, AASHTO
- Dr. Walter Podolny, Jr., Panel Co-Chair, FHWA
- Ms. Nancy McMullin Bobb, FHWA
- Mr. Arthur Hamilton, FHWA
- Mr. Louis N. Triandafilou, FHWA
- Dr. Robert J. Reilly, NCHRP
- Mr. David M. Moskowitz, A.G. Lichtenstein and Associates, Inc., ACEC
- Mr. Ernst Petzold, Sverdrup Civil, Inc., ACEC
- Mr. Fred R. Beckmann, AISC
- Dr. John M. Kulicki, Modjeski and Masters, Inc., ARTBA
- Mr. Frank E. Ward, F. E. Ward, Inc., AGC
- Dr. Basile G. Rabbat, PCA

The trip reporter was Dr. Dennis R. Mertz of the University of Delaware.

Appendix A provides biographical information on the scanning review panel members. Appendix B lists their itinerary.

COUNTRY SUMMARIES

During the review, the panel met with bridge owners, consultants, contractors, and academics from Denmark, Germany, Switzerland, France, and the United Kingdom. In each country, the panel members also visited various bridge sites, both in service and under construction. Although the panel was shown some of Europe's most elegant and grand bridges, panel members' observations and subsequent recommendations reflect common European bridge practices as revealed in discussions with European colleagues rather than practices exemplified solely by the beautiful bridges shown to the panel. For example, in Denmark's Great Belt project, a typical European-style, concrete-deck waterproofing system was observed. Initially, the panel believed that the complicated system was unique to bridges of great capital expenditure, such as the Great Belt; however, it became clear that such a system is common to the whole European bridge population.

Denmark

In Denmark, the panel met with representatives of the Road Directorate of the Denmark Ministry of Transport and Storeblt, the semi-governmental agency established to design, construct, and operate the Great Belt Project.

The panel visited the Great Belt Project, a fixed link and part of an eventual link connecting Denmark to Germany and Sweden. This project is 17.5 km (10.9 mi) long. The current project consists of a tunnel for railway traffic, a suspension bridge with a main span of 1,624 m (5,328 ft) for vehicular traffic across the Eastern Channel to the island of Sprogø, and parallel road and railway bridges from Sprogø across the Western Channel.

The highway bridge across the Eastern Channel will be the world's longest suspension bridge when completed in 1997. One of the suspension bridge's pylons is shown in Figure 1. The railway tunnel will be the second-longest underwater bored tunnel, second only to the tunnel beneath the English Channel. The low bridge across the Western Channel will be Europe's second-longest bridge. The nearly completed low bridge is shown in Figure 2. The suspension bridge's superstructure demonstrates the effect of the European Union on bridge construction. The basic elements of the single-box cross section, the steel plates, were fabricated in Italy, pre-assembled into sections in Portugal, and shipped to Denmark where the bridge was erected.

Architects on the project developed an aesthetically pleasing solution to the typically massive suspension-bridge anchor blocks. The solution, a vertical pier supporting the approach spans with triangular trestles anchoring the cables, is shown in Figure 3.

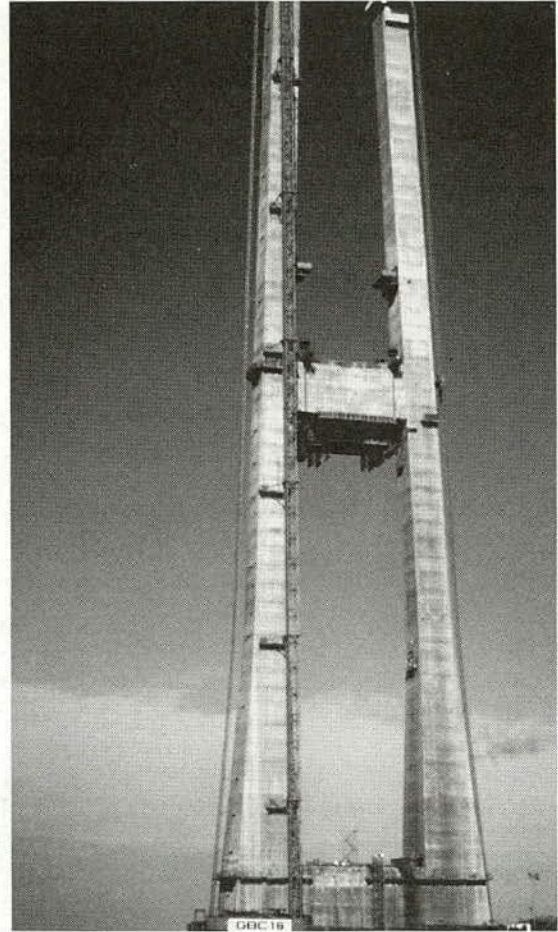

Figure 1. Great Belt Eastern Channel suspension bridge pylon.

Germany

In Germany, the panel met with representatives of the Federal Ministry of Transport in their offices in Bonn.

The panel visited two in-service bridges en route from Bonn to Zurich. The Ahrtal Bridge (Figure 4) is a concrete, segmental, box-girder bridge. Recently, the bridge received an extensive deck rehabilitation, at which time a noise wall was installed—an indication of Europe's increased concerns about the environment. The second site visited was the Mosel Valley Bridge at Dieblich-Winningen, a large single-box steel bridge (with a bottom box width of 10.8 m [35.4 ft]) and a main span of 218 m (715 ft) (Figure 5).

Switzerland

In Switzerland, the panel met with representatives of the Swiss Federal Institute of Technology (Eidgenössische Technische Hochschule) in Zurich and the Swiss Federal Highways Office (SFHO) in their offices in Bern. En route from Zurich to Bern, the panel visited two bridge-rehabilitation sites, the Europa Bridge and the Aare River Railroad Bridge.



Figure 2. Great Belt Western Channel low bridge.

The Europa Bridge (shown from below in Figure 6) is a prestressed, concrete viaduct in Zurich. Because of concerns about the shear capacity of the girders, the bridge was temporarily shored while repairs were made.

The Aare River Railroad Bridge is a steel-truss railway bridge being replaced with a concrete bridge. Although the steel-truss superstructure is being replaced, the existing stone piers are being preserved. The steel bridge is in excellent

condition for a bridge of its 1870s vintage, but land development under the bridge since its completion dictated that a quieter structure be developed. During the panel's visit, the concrete bridge was nearing completion on temporary concrete piers next to the existing steel bridge. To prevent a problem with stray currents from the catenary system, the prestressing tendons are electrically insulated. The concrete bridge will be jacked transversely into position onto the stone

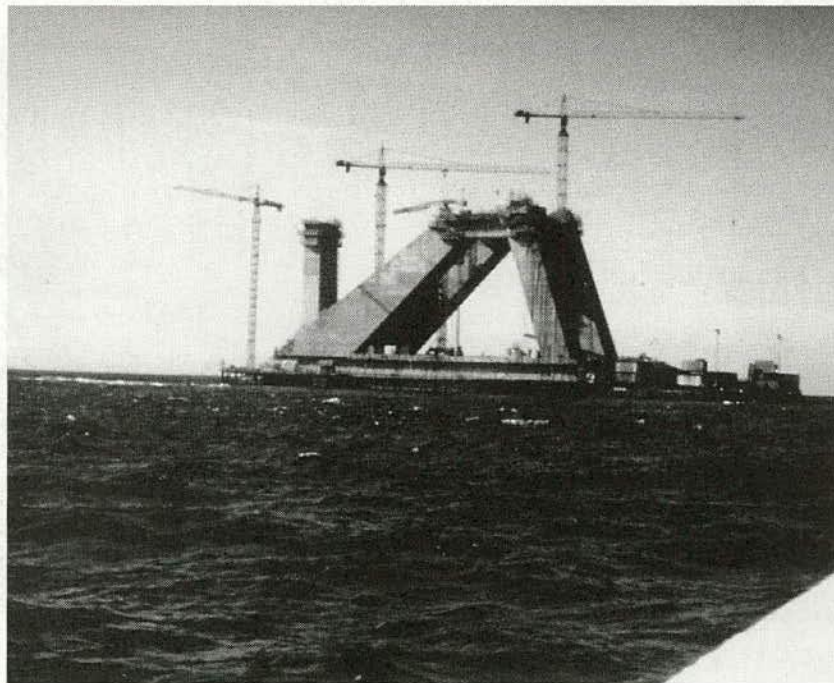

Figure 3. Great Belt suspension bridge anchorage.

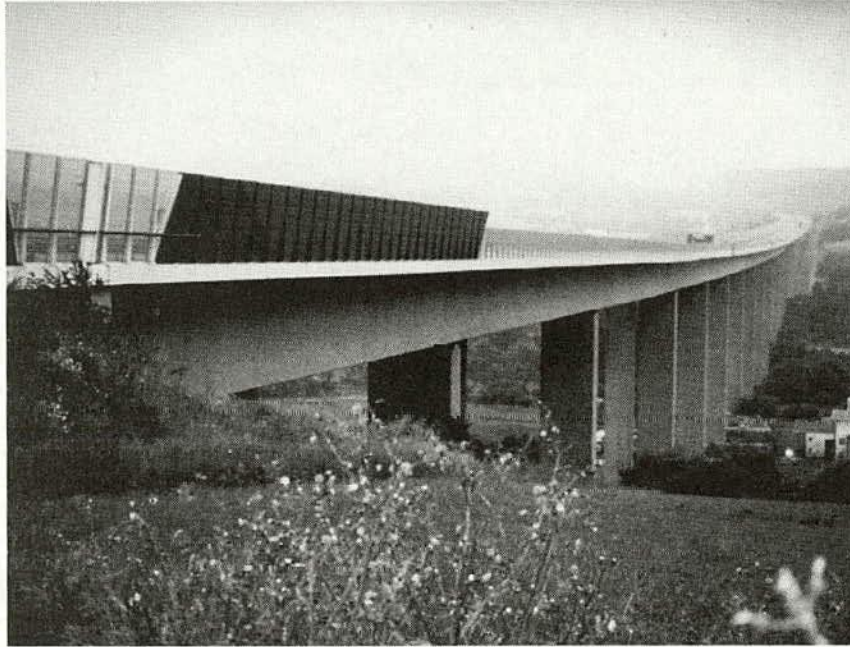

Figure 4. *The Ahrtal Bridge.*

piers, taking the place of the original steel superstructure. The temporary concrete piers will be demolished by boring and packing a set of holes in a grid pattern with a highly expansive grout. The existing piers are being reused—even to the point of reinstalling an original pedestrian suspension bridge connecting them. Figure 7 shows the new concrete bridge beside the existing steel bridge.

The panel visited six in-service bridges. Professor Christian Menn, the designer of many of these bridges, and representatives of the SFHO led these visits.

The Felsenau Bridge (Figure 8) is a prestressed-concrete, single-cell box-girder bridge that is 1,116 m (3,661 ft) long with two main spans of 144 m (472 ft). The bridge was constructed using the free cantilever method between 1972 and

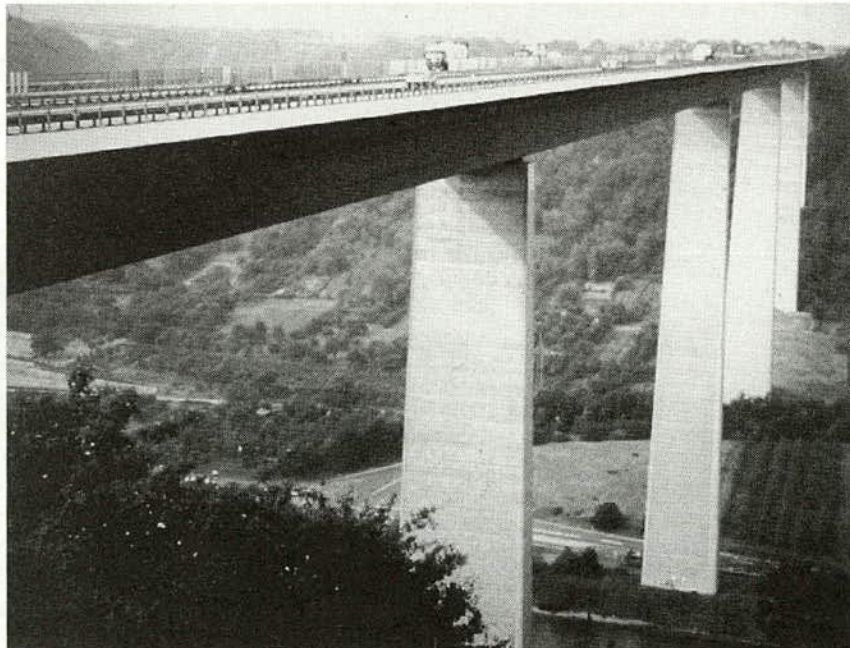

Figure 5. *The Mosel Valley Bridge.*

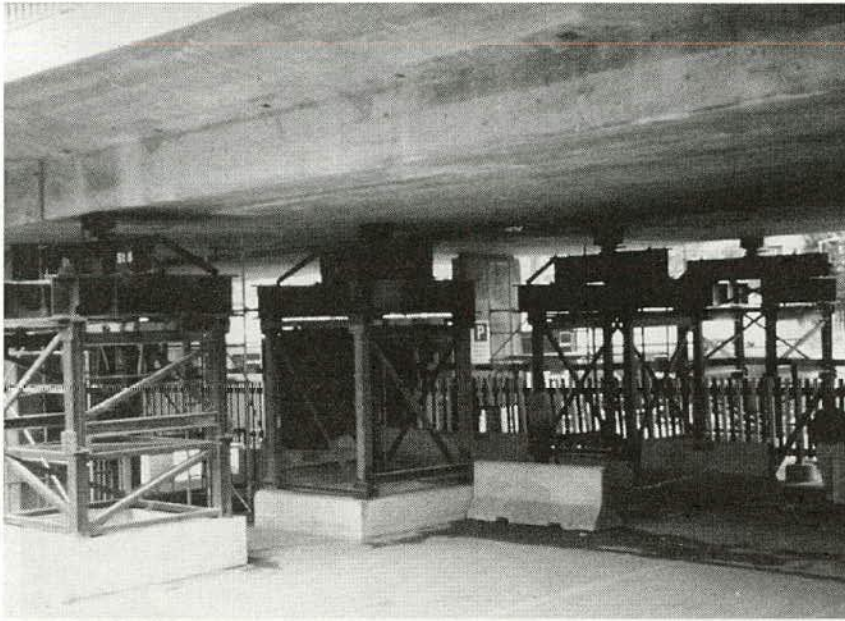

Figure 6. *The Europa Bridge in Zurich.*

1975. As explained by Professor Menn, the bridge's designer, the closely spaced dual-wall piers facilitated construction and enhanced the bridge's aesthetic appeal. Professor Menn expressed concerns about the shear capacity of the bridge (because honeycomb was found over the first pier) and the ability to repair this bridge (because there are no redundant load paths). He also indicated that the deck water-

proofing system is probably not providing its original level of protection.

The Viaduct of Löwenberg (Figure 9) is a dual-launched post-tensioned concrete box-girder bridge.

The Viaduct of Bois de Rosset (Figure 10) is a dual-launched post-tensioned steel box-girder bridge constructed as an experiment. The twin octagonal piers at each box-

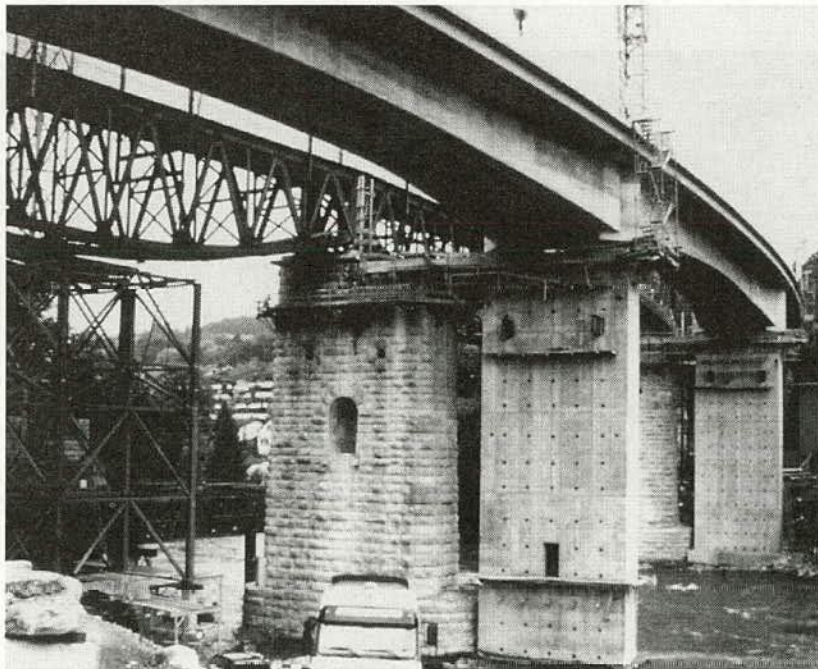

Figure 7. *The Aare River Railroad Bridge.*

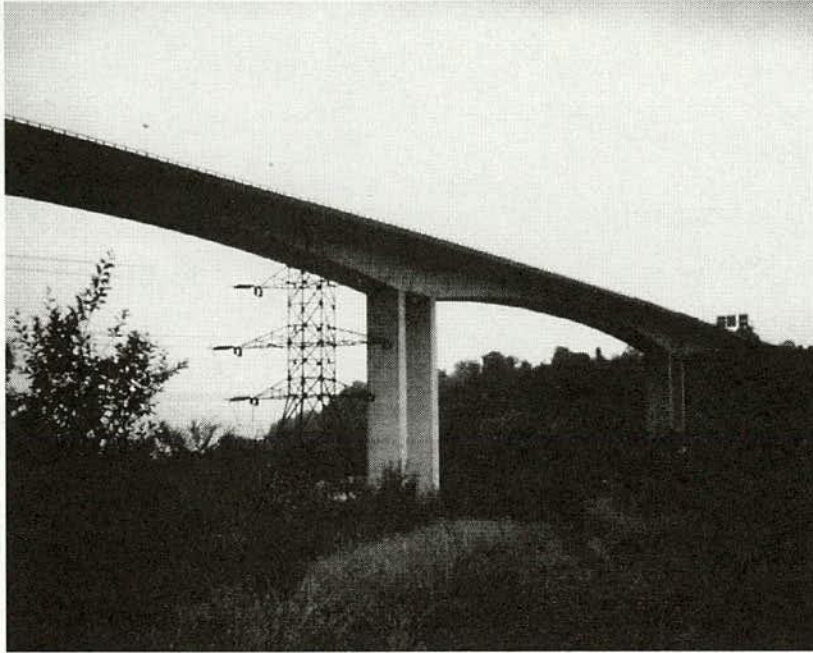

Figure 8. *The Felsenau Bridge.*

girder support constitute a unique feature. The piers, with two per girder and two girders for the crossing, look like a forest and are considered by some to be unattractive. In comparison to the traditional steel bridge construction, building the post-tensioned steel bridge contributed little, if any, savings.

The two parallel viaducts at Chillon (Figure 11) are 2,150 m (7,054 ft) long. The steep, wooded slopes of Chillon

along Lake Geneva posed quite a challenge to construction from 1966 to 1969. The construction was accomplished using precast segments and a traveling construction truss to lower them into position for post tensioning. The Chillon Viaduct will soon undergo rehabilitation to correct span sag, which has occurred at spans with expansion joints.

The Chandoline Bridge at Sion (Figure 12) is a cable-stayed concrete bridge that is 284 m (932 ft) long and has a



Figure 9. *The Viaduct of Löwenberg.*



Figure 10. *The Viaduct of Bois de Rosset.*

main span of 140 m (459 ft)—short by typical cable-stayed bridge proportions but selected for aesthetic reasons. Professor Menn also designed this bridge.

Finally, the Ganter Bridge at Simplon Pass (Figure 13) is Professor Menn's signature bridge; it is 1,260 m (4,134 ft) long. At the time of construction (from 1976 to 1980), the concrete structure with a main span of 174 m (571 ft) was a world-record holder.

France

In France, the panel met with representatives of the Roads and Highways Engineering Department (Service d'Etudes Techniques des Routes et Autoroutes [SETRA]), the Public Works Central Laboratory (Laboratoire Central des Ponts et Chaussées [LCPC]) and several representatives from private practice—all in Paris.

En route from Paris to London, the panel visited the Normandy Bridge, the world's longest cable-stayed bridge with a main span of 856 m (2,808 ft). Normandy Bridge, owned by the Chambre de Commerce et de l'Industrie du Havre, provides an additional crossing of the Seine, complementing the Chambre's nearby Tancarville Bridge, a suspension bridge with a main span of 608 m (1,995 ft).

The inverted Y-shaped pylons (Figure 14) are an aesthetically pleasing solution to the prime design consideration, wind resistance, and an aesthetic success. The design wind speeds are 200 km/h (124 mph) at the top of the tower, 130 km/h (81 mph) at 10 m (32.8 ft) above the deck, and 120 km/h (75 mph) at the deck level. The maximum average wind speed ever measured on the nearby Tancarville Bridge was 120 km/h (75 mph), and the highest measured wind speed at its tower top was 180 km/h (112 mph). The 23.6-m (77.4-ft)-wide single-box-girder bridge has semicircular wind fairings.

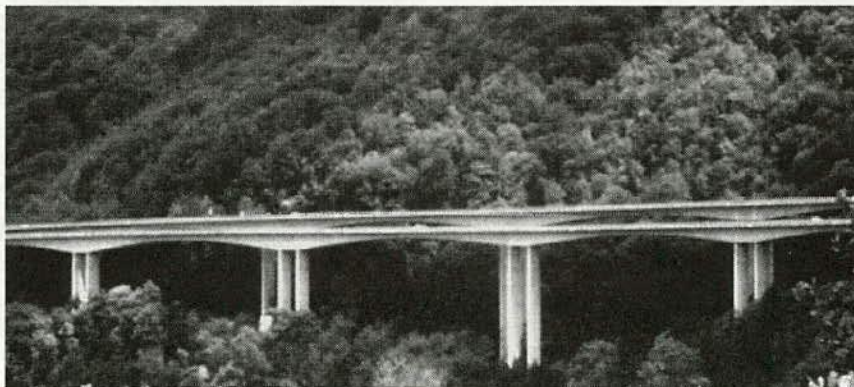

Figure 11. *The Viaducts at Chillon.*

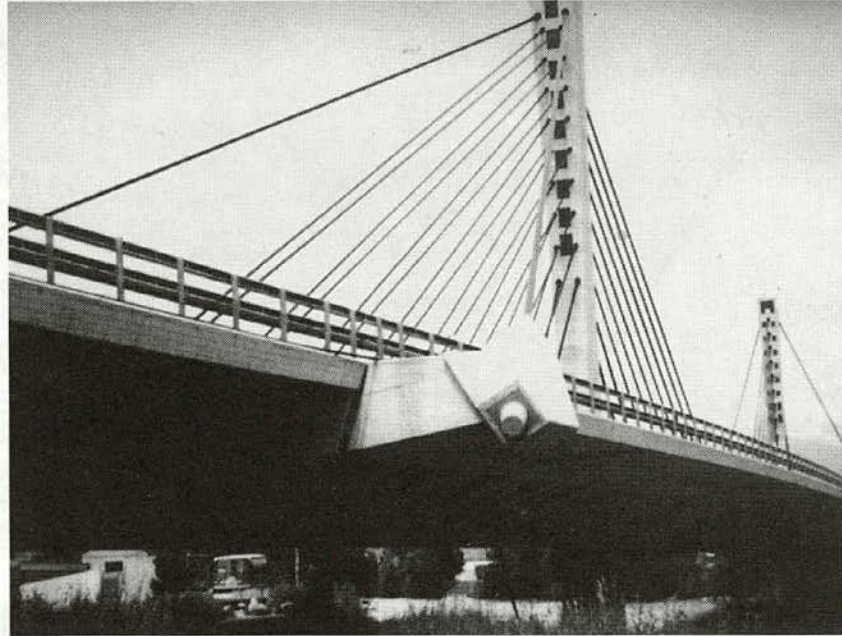

Figure 12. *The Chandoline Bridge at Sion.*

The Normandy Bridge cable system consists of seven-wire, galvanized, wax-coated, shielded strands anchored with wedges within a two-piece, plastic pipe with partial-length, low-rise strakes. These strakes address the wind- and rain-induced vibration problem encountered on other cable-stayed bridges. The stays are interconnected with orthogonal tuning ropes. Longer stays have dampers attached to the deck for further cable-vibration suppression.

Although most of the bridge is concrete, the central 624 m (2,047 ft) of the main span consists of prefabricated steel segments to reduce dead load. Further, within each tower, structural-steel tension weldments are used to facilitate connection of the stay cables. To facilitate maintenance and inspection, an access train was installed under the main span.

The approach spans and side spans of the cable-stayed bridge were constructed using incremental launching involv-

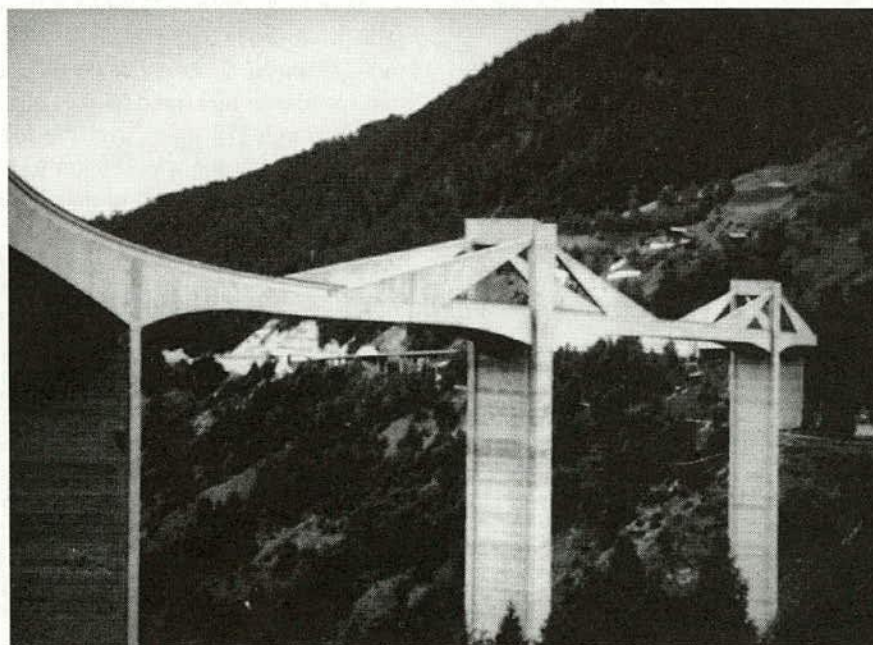

Figure 13. *The Ganter Bridge at Simplon Pass.*

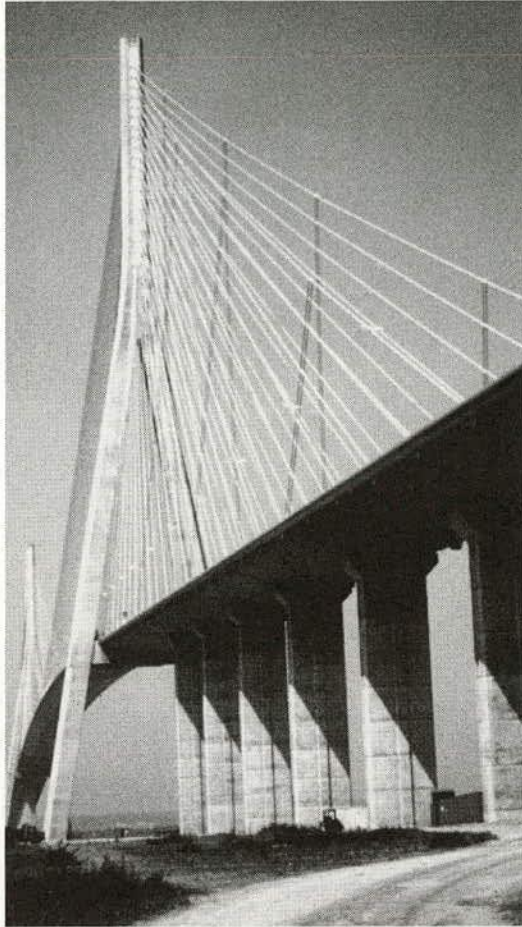

Figure 14. *The Normandy Bridge.*

ing lifting and then pushing the spans into place. The concrete portion of the center span of the cable-stayed bridge, next to the pylons, was constructed using the balanced cantilever method, with the steel prefabricated segments lifted into position from barges in the river and welded together.

The United Kingdom

In the United Kingdom, the panel met with representatives of the Civil Engineering and Environmental Policy Directorate of the Highways Agency of the Department of Transport in their offices, and representatives from private practice—all in London.

The panel visited the advanced-composite-material Bonds Mill movable bridge and the Second Severn Crossing.

The Bonds Mill Bridge is a bascule-span movable bridge over a canal linking the Severn and Thames rivers. Figure 15 shows the Bonds Mill Bridge during the panel's site visit. The bridge, opened to traffic on July 16, 1994, is an advanced-composite-material structure with lightweight Acme panels for the bridge deck. It was the world's first advanced-composite-material vehicular bridge. The bridge has a span length of 8.2 m (26.9 ft) and a width of 4.8 m (15.7 ft). Because it provides access to an industrial site, the bridge carries significant truck traffic. The material and fabrication cost is estimated to be 90,000 (\$150,000) with the Canal Trust providing the necessary labor. The bridge was designed and built in 9 months. The bridge was said to weigh one quarter of the weight of a conventional bascule. This weight saving, although at increased cost, led to saving in the mechanical and electrical requirements to lift the bascule

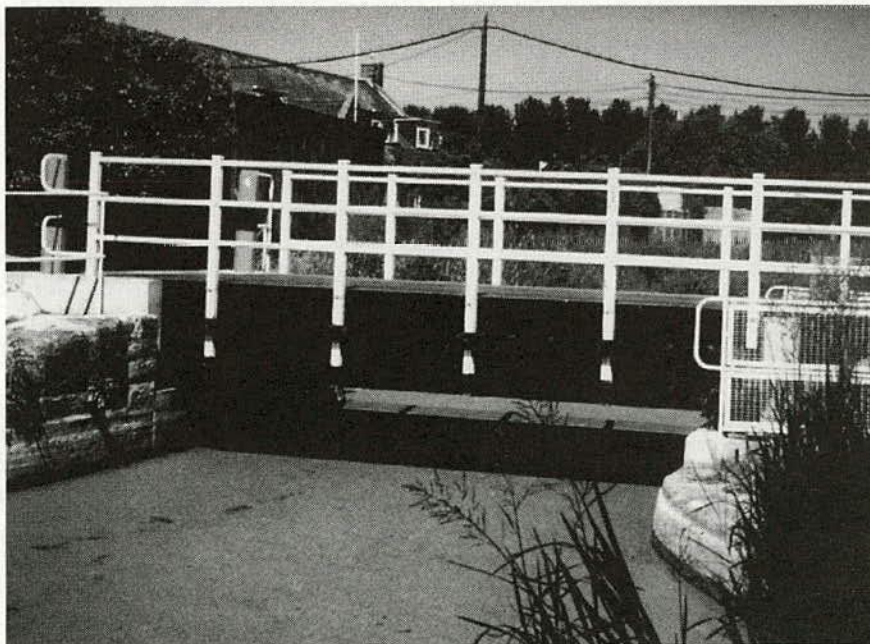

Figure 15. *The Bonds Mill Bridge.*

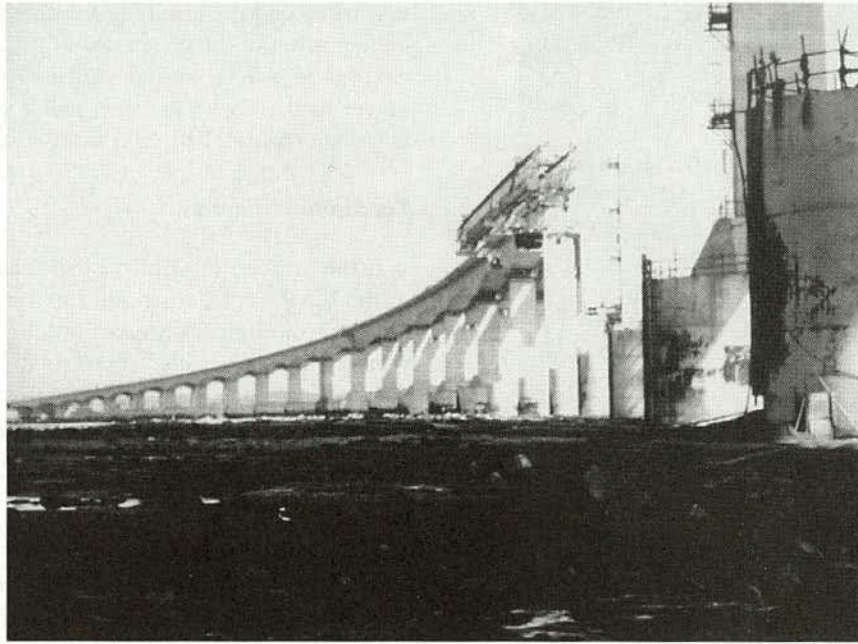

Figure 16. The concrete viaducts of the Second Severn Crossing Bridge.

span. Live-load deflection, a critical limit state for advanced-composite-material bridges, was limited to the span length divided by 120. The bridge remains in the closed position until canal traffic requires its opening, and it was not opened during the panel's site visit.

The Second Severn Crossing is a 456-m (1,496-ft)-main span cable-stayed bridge over the navigation channel with approach viaducts, each over 2 km (1.2 mi) long, crossing the Severn Estuary connecting England to Wales, and is under construction. The concrete viaducts, shown in Figure 16, are being constructed using precast, reinforced-concrete segments, which are lifted into position on each end of a balanced cantilever and then epoxy-jointed and post-tensioned together. The viaduct spans are 98 m (322 ft) long consisting of 27 match-cast segments each. The cable-stayed bridge, shown in Figure 17, is being constructed using 34.6-m-wide by 7-m-long prefabricated structural-steel segments. The bridge is constructed using the balanced cantilever method, with the steel segments lifted into place from barges in the estuary and bolted into place and followed by securing of the prefabricated cable stays. The bridge construction is a part of a design-build-maintain-operate contract. The concessionaire will operate the bridge for 25 years and then turn it over to the government. Several noteworthy features are being employed on the bridge. For example, specially developed 3-m (9.8-ft)-high windshields will be installed along the edges of the deck. Also, a moveable platform will run from one end of the bridge to the other to provide access for maintenance and inspection. The platform will be suspended beneath the deck, with drop-off stations along the way. Furthermore, the prestressing tendons in the approach spans and cable stays can be replaced without closing the structure.

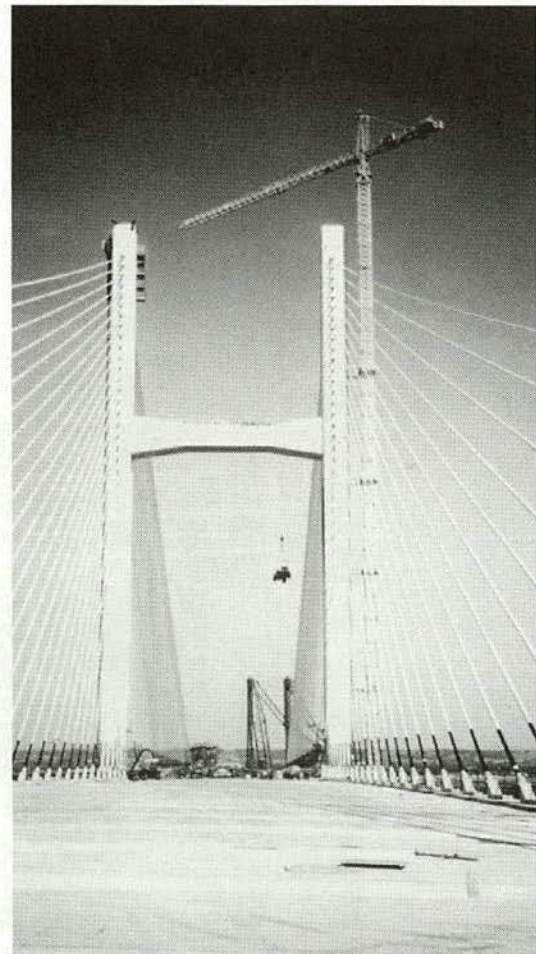

Figure 17. The cable-stayed bridge of the Second Severn Crossing.

CHAPTER 2

OBSERVATIONS, DISCUSSIONS, AND RECOMMENDATIONS

The observations and recommendations presented here reflect the panel members' collective impression of the meetings and site visits made during the scanning review. The panel assembled the summary during a mid-review meeting in Paris and a post-review meeting in London, with a subset of the panel reviewing them again at a meeting more than a month after returning to the United States. Comparisons of European technology with U.S. domestic practice and judgments about the relative merits of each are not warranted because the panel's visit was so brief. Differences are noted in the discussions that follow.

Observations about each country typically are cited in the following order: Denmark, Germany, Switzerland, France, and the United Kingdom. Not all topics were discussed in each country. If an observation was not made in a particular country, it does not mean that country was not also doing what was observed elsewhere.

The panel's observations are, for the most part, a result of discussions with European colleagues. Because the panel's visit to each country was so short, panel members could not observe all, or even many, aspects of bridge engineering first hand; therefore, their observations reflect secondhand information provided to them by their hosts and information obtained in the course of visits to particular bridge projects.

POLICY, ADMINISTRATION, AND MANAGEMENT

The panel made the following observations relating to policy, administration, and management of bridges in Europe.

Shared Risk and Responsibility

Bridge owners, designers, and contractors in Denmark, Germany, Switzerland, and France seem more willing to implement innovations and to accept higher levels of risk than their counterparts in the United Kingdom and the United States. Denmark, Germany, Switzerland, and France are less litigious and, therefore, designers and contractors are less fearful of making mistakes. The European bridge design and construction community shares responsibility for implementing innovative concepts. All the parties—the owner, the designer, and the contractor—seem to share responsibility

for the success or failure of the concept. If the bridge proves less durable than hoped, the owner shoulders the cost of a repair or replacement. Similarly, if the design or construction effort exceeds their estimates, the designer or contractor shoulders the increased costs. Ideally, all participants, and society in general, benefit from innovation.

Some panel members have suggested that the Europeans have a less demanding environment—in terms of nature and society—in which to design and construct bridges. Some of the more extreme conditions of nature that U.S. designs must address do not exist in the areas visited by the panel. Denmark, Germany, Switzerland, France, and the United Kingdom are relatively free from earthquakes. Having to address fewer potential threats to bridges may allow Europeans to be more innovative and confident.

During many of the visits, panel members heard of practices that suggest that all parties share the responsibility for innovation and the potential risks. For example, in Denmark, the state provides “umbrella” insurance coverage for engineers and contractors. In Switzerland, bridge owners, consultants, contractors, and academia cooperate closely to solve problems; and “proof engineers” (i.e., respected senior bridge experts, who are often university professors) oversee designs and give final seals of approval. In addition, engineering experts resolve technical disputes—not judges and the legal system—so that technical concerns do not become clouded by legal and emotional issues.

In the United States, if a problem arises in bridge design, construction, or even during the service life of the bridge, one of the participants may begin litigation to recoup unforeseen costs. In attempting to innovate and potentially save money, U.S. design consultants, contractors, and owners risk litigation. Furthermore, design consultants and contractors have little incentive to innovate, other than that innovation may make their participation in the project possible.

The Europeans are allowed to put greater confidence in their competence, technologies, and systems because European culture is less litigious. This environment allows the Europeans to take more risks to advance bridge technology. The panel observed many practices in Europe (including less-redundant bridges, lower fatigue-resistant details, and field welding) that are considered undesirable by current U.S. standards. For example, less-redundant systems (e.g., two-girder bridges, single lower steel chords, and single welded-

steel boxes) are used in France. Less-redundant systems are neither seen as a special risk nor given a fracture-critical designation as is the case in the United States. The French designers, who are very confident in their calculations of force effects, also use some Category D, E, and E' details in welded-steel bridges that U.S. designers would tend to avoid. In Europe, field welding is used for field splices—even to the extent of using movable sheds to control the local environment to protect the welding process. Field welding is being used in the United States in a few states, including Georgia and Texas.

Because American society is litigious, bridge designers rely on more proven technologies and systems and tend to be very conservative regarding those aspects of bridge design and construction over which they have less control. For example, because designers have little or no control of quality in the shop or field, their designs will assume less quality in these situations than is true for European counterparts. It is not that U.S. designers believe that contractors cannot achieve the quality of European work—U.S. designers are merely limiting their liability by producing more foolproof designs.

The panel encourages bridge owners to support innovation by sharing risk and responsibility for new bridge design and construction concepts with designers and contractors.

Public Interest in Bridges

Customer, or bridge user, satisfaction is very important to the Europeans. The panel perceived great public awareness of bridges and the investment they represent, especially in Switzerland and France. For example, about 1 percent of the gross national product in Switzerland is being invested in bridge and road repair. In Europe, all bridges are considered part of history and culture. In the United States, this is true only for certain bridges (e.g., the Brooklyn Bridge and the Golden Gate Bridge).

To develop political support for funding, engineers in Switzerland emphasize the benefit of enhancing the public's awareness of their ownership of the infrastructure. They enhance public awareness of the infrastructure by relating the nation's infrastructure investment on a per capita basis and relating the cost of deferred bridge maintenance, for example, to that of deferring needed maintenance on a household appliance.

The panel was told that the French public is so aware of the condition of their roads and bridges that sometimes the issues of roads and bridges play a role in the election of public officials. The beautiful visitors' center at the Normandy Bridge, which includes a monument to the engineers involved in constructing the bridge, demonstrates the French public's appreciation of their bridges.

Estimates of the per capita value of U.S. infrastructure by various agencies vary from about \$4,000 to \$6,000. If made aware of this level of investment, the public might be more

easily persuaded of the need to maintain and replace the aging infrastructure.

The panel encourages a research-funding agency to develop an informational package promoting public awareness of how bridge and highway investment benefit the United States.

Warranties and Liabilities

In Denmark, the contractor warrants the bridge-deck protection system for 5 years. In Germany and Switzerland, the contractor warrants workmanship and materials for 5 years. In France, the contractor warrants workmanship and materials for 10 years and will share equally in the cost of warranty repair with the government when the bridge is designed by the government but will be responsible for all repairs when designed by the contractor. Before the warranty expires, a special inspection is performed to reveal deficiencies. Contractors for bridge projects in the United Kingdom are required to provide a 1-year general warranty, with a longer warranty for special products such as expansion joints and bearings.

The Europeans do not require their contractors to be responsible for the design of bridges designed by others; only if the contractor finalizes designs, does the contractor's warranty apply to the design.

Swiss researchers are absolved of liability if their ideas are used in specifications, but they retain no intellectual property rights to these ideas. The Swiss researchers are compensated for loss of intellectual property rights by higher salaries.

In the United Kingdom, when alternative designs are prepared by the contractor, the government's engineer reviews and approves the design submitted by the contractor. In doing so, the government's engineer becomes liable for the contractor's alternative design.

In the United States, the designer is expected to take responsibility for the accuracy of the design and design plans, and the builder is expected to take responsibility for constructing the project in accordance with those plans to an acceptable level of workmanship. These obligations extend for the statute of limitations, which often is longer than European warranties. U.S. practice regarding warranties is summarized in *NCHRP Synthesis of Highway Practice 195: Use of Warranties in Road Construction*.

The panel encourages a research-funding agency (e.g., the FHWA, NCHRP, or another organization) to develop or undertake a study to reevaluate contractor warranties for compatibility with the U.S. legal system.

Funding Directions

As their basic road networks mature, most European countries are directing or plan to direct more money toward maintenance, repair, and rehabilitation, rather than new construction.

The Danish Road Directorate allocates twice as much money for bridge maintenance, rehabilitation, and repair as they do for new bridge construction.

In Germany, 1.5 to 2.0 billion DM of federal funds are spent annually on bridges; 80 percent (1.2 to 1.6 billion DM) are spent for new construction and 20 percent (300 to 400 million DM) are spent for the repair and rehabilitation of 600 to 800 bridges. The German Ministry of Transport estimates that by the year 2000, 900 million DM will be required annually for bridge maintenance. The German Ministry of Transport believes that more money is being spent today on bridge projects because of increased awareness of environmental concerns. For example, sound barriers are a common noise-mitigation measure. The panel observed a recently completed bridge-mounted noise wall in a rural area, where the need for the wall seemed questionable within the context of U.S. experience. This illustrates how the Europeans seem even more sensitive about environmental issues than we are in the United States.

In France, about 350 bridges are replaced or constructed annually at an average cost per bridge of 4.5 million francs. Also, about 90 bridges are rehabilitated annually at an average cost per bridge of 2.5 million francs. The total rehabilitation funding represents about 0.4 percent of the capital cost of all bridges. Sixty million francs are spent yearly for bridge maintenance (0.1 percent of the capital cost of all bridges).

The panel encourages bridge owners to consider increased funding for routine maintenance.

Aesthetic Concerns

The panel's trips on various modes of ground transportation demonstrated that the European countries, particularly Switzerland and France, give aesthetics more consideration than U.S. state DOTs do. This was indicated in most of the meetings that the panel attended and supported by the panel's observations of many beautiful bridges in the countries visited.

The Danish Road Directorate uses architects to influence the aesthetics of bridges.

The German Ministry of Transport uses architects as consultants to the engineer for urban or visually sensitive projects. The engineer determines the bridge type, and then the architect recommends aesthetic enhancements of the design. The Ministry of Transport thinks that engineers need more training in aesthetic considerations. Where the Ministry wishes to maintain a certain character along an entire corridor, a state-chosen architect is involved from the beginning of the project to establish the aesthetic guidelines for the route. Although aesthetic concerns are important, economy and ease of maintenance are considered more important.

In Switzerland, the panel saw bridges, such as the Viaducts at Chillon and the Chandoline Bridge at Sion (Figures 11 and 12), that illustrate a commitment to bridge aesthetics. In France, bridges on each stretch of a new motorway are built of one or two different structural types, chosen in consulta-

tion with an independent architect, in order to achieve aesthetic continuity. The U.K. Department of Transport has an architect on staff. In addition, the Royal Fine Arts Commission gets involved with one or two bridges a year. Further public attention may be drawn to bridge aesthetics because Prince Charles is publishing a book on architectural aesthetics that includes a section on bridges. Generally, the consultants in the United Kingdom believe that the measure of quality is too heavily biased toward aesthetics.

In the United States, bridge owners and designers generally make a conscious decision on selecting a bridge design that will be pleasing to the eye when constructed. For selection of the new Severn River Bridge in Annapolis, the Maryland State Highway Administration used a formula that accounted for aesthetic considerations and associated increase in initial cost. Also, the state has developed a manual that suggests that much can be done to enhance bridge aesthetics without increasing initial cost.

The panel encourages state DOTs and the FHWA to give aesthetics more consideration when evaluating bridge projects.

Initial Cost and Life-Cycle Cost

Initial cost, aesthetics, future maintenance, and other concerns are considered in order to select a bridge type; however, initial cost does not dominate the bridge-selection process in most of the countries visited. The Europeans apply life-cycle cost concepts and, in general, seek a 100-year bridge life. In Switzerland, life-cycle cost concepts are considered and include construction, commissioning, use, decommissioning, and demolition. In the United Kingdom, "whole life cost" is the concept used in selecting bridge-type systems.

Although only the Swiss and British representatives specifically mentioned life-cycle costs, the discussions revealed that life-cycle cost concepts are being used throughout most of Europe, though not necessarily through formalized algorithms. When the Europeans described how the relative merits of design alternatives (e.g., bridge-deck waterproofing systems) are judged, it became clear that life-cycle cost concepts are being considered in choosing the best alternative.

Bridge projects in Germany are prioritized by their benefit-cost ratio. During the next two decades, only projects with a benefit-cost ratio better than 3 to 1 will be built.

Although the European colleagues expressed an interest in obtaining a 100-year service life, there is no evidence that this goal is being achieved for European bridges. With the advent of the AASHTO *LRFD Bridge Design Specifications*, U.S. bridge designers will be designing bridges for a 75-year design life.

The federal government has mandated that life-cycle costs be considered during procurement. The National Highway System Designation Act of November 1995 required that

life-cycle costs be considered for all federal-aid projects estimated at \$25 million or more. The methodology to do this is evolving slowly.

Design-Delivery and Project-Delivery Systems

Various design-delivery and project-delivery systems are in use in the countries visited; some of which are similar to current U.S. practice. The visited countries employ unique contracting methods that are reputed to promote innovation, economy, and long service life.

In Germany, the conceptual design is developed by the Ministry without contractor involvement. The contractor prepares the bridge plans and specifications and can provide alternative designs reflecting the Ministry's concept and guidelines. (Contractor alternatives were said to usually be less aesthetically pleasing than the Ministry's designs.)

In Switzerland, the SFHO awards bridge-engineering contracts through different procedures. The most common procedure for a small project is a single mandate, in which one consulting engineering firm is appointed to design a bridge and the design is reviewed by an expert retained by the federal government. The procedure preferred by the SFHO involves a parallel mandate, in which two or more consulting firms are assigned, and paid, to design a particular bridge. A panel of experts from the canton and federal government reviews the work, and two or more of the sets of contract drawings and provisions are put out to bid. All other efforts, fully paid to this point, are discontinued or have been discontinued earlier. When the SFHO is "looking for an idea," a design competition is conducted. The winner, selected by a jury of qualified professionals, is awarded the design contract and a cash first prize; other top finishers are also awarded a cash prize. The cash prizes do not cover consultant costs, but consultants enter hoping to win the design contract. However, in the rare cases when the SFHO is "looking for an idea" concerning a very large project, a design and construct competition is conducted to allow the input of contractors. This procedure is reported to result in poor quality. The design engineer, as an employee or subcontractor to the general contractor, may be under pressure to "cut corners" in the design to develop a more easily constructed, but less durable, bridge.

The design-competition concept is used for larger projects where innovation is sought. The designs are evaluated and rated according to a bridge-specific formula that accounts for several factors. For example, for a recent project, 60 percent was allocated for conception and construction, including general conception of the project and durability and risk during, and after, construction; 20 percent for aesthetics and integration with site; and 20 percent for cost (clearly less of a factor in a design competition).

Usually five to seven submitters are invited to participate in the competition. For a recent project, each invited submitter received 80,000 Swiss francs (\$73,000). Submitters may

receive an additional 25,000 to 30,000 Swiss francs (\$23,000 to \$27,000), depending on the quality of the submission.

French engineers use the concept of "best value" rather than "least cost." The best value concept considers quality, time of construction, cost, and other factors. For major bridges, designs are sought through design competitions in which contractors offer alternative designs or in response to conceptual design where the contractor generates final plans on the basis of conceptual plans that now provide more details than was so 10 to 20 years ago.

In the United Kingdom, the two-envelope system (i.e., one envelope for the technical proposal and another envelope for the price proposal) is used by the government agency, much to the dissatisfaction of the consultants. Consultant contracts in the United Kingdom are of the lump-sum type. The consultants believe that too much emphasis is placed on the fee; however, they also believe that the United Kingdom may be moving away from the two-envelope system and placing more emphasis on quality design. They see a potential trend toward use of design/build/finance/operate rather than the traditional design/build concept.

Each country has a slightly different approach to the design and construction of bridges; however, these approaches are not inherently tied to the specific cultures of the countries but seen as creative solutions to a common problem. Therefore, the panel does not perceive any inherent obstacle to using these methods in the United States.

The predominant method of project delivery in the United States is often referred to as "design-bid-build." In this system, the owner supplies the design to the contractor who builds the project and, at completion, transfers it to the owner. The design is performed in-house by the owner or is completed by a designer selected by the owner. Different procedures are used for selecting designers; usually, these procedures are aimed at selecting the most qualified designer for the project at hand. The designer's fee for the project may or may not be of issue in the selection process. The bidding may be open to all designers, if a Request for Proposals (or Qualifications) is published, for example, or the owner may restrict the bidding by inviting only certain firms to participate. Although other criteria may have been used, the design usually is chosen on the basis of lowest expected initial cost. In the past, the use of alternative designs for major bridges has been used. In this procedure, two designs have been prepared (usually using competing materials) and bid for construction. The design offered in the bid that has the lowest cost is usually the one constructed. The use of alternative designs is at the discretion of the owner. Having designed the project, the owner advertises the project for construction. Prequalification of contractors is done by some owners. The bidding period is typically 3 to 4 weeks with a longer period allowed for large and complicated projects, at which time the contractor submitting the lowest responsive bid is typically awarded the contract. On final acceptance by the owner, the owner assumes responsibility for the project and its operation

and maintenance. With this method, the owner has a contract with the designer for the design and with the contractor for construction. There is usually no contractual relationship between the designer and the contractor.

Although the design-bid-build system is the most common in the United States, other project delivery systems are (or have been) used. These include design-build and build-own-operate-transfer—systems similar to some of the methods used in the countries visited.

Considering the successful European application of contracting methods differing from those in use in the United States, and given the possibility of their equally successful application in this country, the panel encourages the FHWA, NCHRP, or another research-funding agency to undertake a comprehensive evaluation of domestic and European project-delivery systems. Also, the panel encourages bridge owners to consider peer review for the design of major and unusual bridges.

Research Programs

The research programs of the European agencies that the panel visited appear to be dedicated to solving current problems with implementation of the research as the measure of success. The panel did not observe ongoing, long-term, basic research programs. This may, however, only be true of the institutions visited by the panel.

In the United States, the NCHRP and the FHWA conduct the kind of research observed by the panel in Europe; however, in addition, the FHWA and the National Science Foundation (NSF) conduct long-term basic research to develop far-term solutions to bridge engineering problems.

DESIGN PHILOSOPHIES, CONCEPTS, METHODOLOGIES, AND SPECIFICATIONS

The following are the observations made by the panel relating to European bridge design philosophies, concepts, methodologies, and specifications.

Unconventional Structural Systems

In Europe, steel space-frames have been used on several major bridges. Continuous hybrid structures, where the unique properties of steel and concrete are used to their best advantage, and where discrete portions of the structure are built from each material, have been successfully constructed.

In France, designers have used unconventional structural systems in searching for aesthetic solutions and exploring the performance envelopes of new systems. Tubular-steel-concrete-composite space-frame bridges have been built using offshore-oil-platform technology and node joints. An example, shown to the panel in a slide presentation, was a steel arch with a triangular cross section consisting of the

roadway sitting on top of a single tubular steel rib. The cross section of the tubular metal arch over the A75 motorway at the Antrenas interchange is shown in Figure 18.

The Normandy Bridge in France is constructed of both concrete and steel. Although most of the bridge is made of concrete, the central 624 m (2,047 ft) of the main span consists of prefabricated steel segments to reduce dead load. Further, within each tower, structural-steel tension weldments facilitate connection of the stay cables.

Steel space-frame bridge designs have not been used in the United States. Domestic bridge designs are overwhelmingly orthogonal grids or, at best, parallel-piped configurations for skewed bridges. Technology to fabricate a space-frame bridge exists, not in the steel bridge fabricator community but among offshore-oil platform fabricators.

Examples of bridges using the unique properties of steel and concrete to best advantage in the superstructure exist in the United States. One such example is the cable-stayed Bayview Bridge across the Mississippi River in Quincy, Illinois. However, few go as far as the Normandy Bridge or the more common bridge designs in France in using hybrid designs.

The panel encourages the FHWA to sponsor projects to demonstrate the use of three-dimensional steel or steel-concrete composite space-frame superstructures.

Construction Materials

Europeans have found that bridges require periodic maintenance, regardless of the construction material used. After

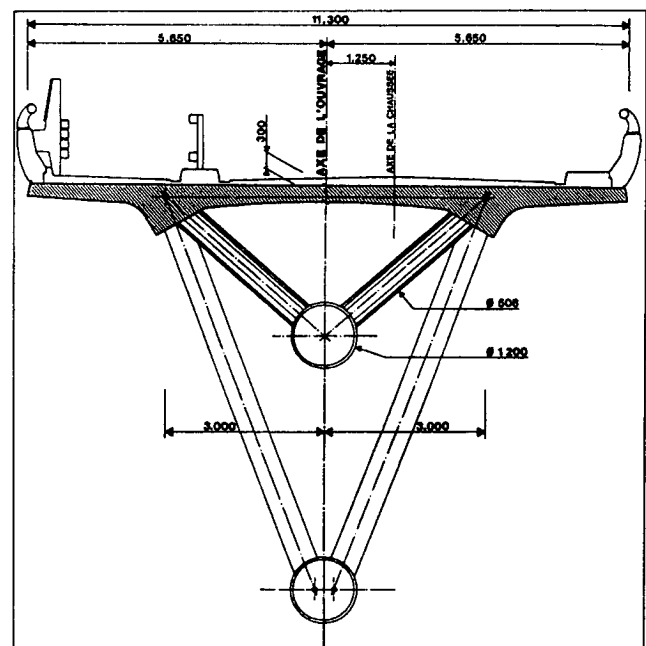

Figure 18. Cross section of French tubular arch bridge.

years of choosing to use concrete in building bridges because concrete was perceived as requiring less maintenance, some of the Europeans now believe that all bridges, regardless of material, require maintenance with time.

In Germany, there is a move toward more equal use of segmental concrete and fabricated steel construction. Also, use of composite-steel construction is increasing while use of prestressed-concrete construction is decreasing. As explained by Ministry of Transport personnel, this trend is attributed to the decreasing cost of fabricated steel in Europe and the unexpected maintenance and repair costs for the joints of prestressed-concrete bridges, bringing the maintenance costs of concrete structures closer to the expected reduced maintenance costs of their steel counterparts. In addition, steel provides greater flexibility with regard to aesthetic considerations, including the ability to paint steel bridges in various colors.

Many U.S. bridge owners believe that concrete bridges require less maintenance than their steel counterparts, primarily because of the periodic need to repaint non-weathering steel.

Use of Deck Overhangs and Beam Elements

The Europeans use large deck overhangs and few beam elements. Throughout Europe, the panel noted single-cell box-girders, of both concrete and steel, with relatively large overhangs. These features are evident in the Ahrtal Bridge (Figure 4), the Mosel Valley Bridge (Figure 5), the Europa Bridge (Figure 6), the Aare River Railroad Bridge (Figure 7), the Felsenau Bridge (Figure 8), the Viaduct of Löwenberg (Figure 9), the Viaduct of Bois de Rosset (Figure 10), and the Viaducts at Chillon (Figure 11).

In France, less redundant systems (e.g., two-girder bridges; single lower chord bridges; and single, welded boxes) are used with confidence in their quality and state of knowledge. Discussions with French bridge designers revealed that they have few, if any, concerns regarding non-redundant systems, which are classified as fracture-critical in the United States.

Partial Prestressing

Post-tensioning is relied on to control deck cracking. External post-tensioning for new concrete bridges is being used extensively and not only to provide overall continuity. Partial post-tensioning is used in some European countries and is seen to have a logical place in the continuum between the use of fully prestressed concrete where no concrete cracking is allowed under service loads and conventionally reinforced concrete where the tensile strength of concrete is ignored and design is based on a cracked condition under service loads.

In France, external prestressing of concrete bridges is common and well regarded. External post-tensioning has

been used to strengthen bridges in the United Kingdom and has not been subject to the recent moratorium on internal post-tensioning.

These observations are also true for U.S. practice except for the use of partial post-tensioning. Although the AASHTO *LRFD Bridge Design Specifications* allows partial prestressing, little use of it is anticipated.

BRIDGE RATING AND EUROCODE DEVELOPMENT

The United Kingdom rates all bridges for current loads and regulations for design; although they have issued "relaxations" criteria for evaluation and assessment of bridges, they apply these relaxations only where necessary and justified. Existing bridges that are to be replaced are tested to learn more about structural behavior at ultimate failure, material properties, and other performance issues.

The development of the Eurocode is progressing but not as quickly as was believed. The panel received conflicting information about the progress.

The panel encourages the AASHTO Highway Subcommittee on Bridges and Structures to develop bridge-rating specifications that reflect the latest design specifications and, perhaps through the NCHRP, review and participate in developing the Eurocode. Also, the panel recommends that the FHWA prepare a technical advisory recommending field testing to destruction of bridges designated for demolition and replacement.

Jointless Construction

All of the European countries are moving toward using as few joints as possible with jointless and integral bridges being preferred. Structures continuous between joints ranging from 600 to 1,100 m (2,000 to 3,600 ft) have been used.

In Switzerland, jointless bridges are used as much as possible. In the United Kingdom, avoiding the use of bridge joints is recommended. If a joint is used, access to inspect the joint must be provided. Further, jointless, integral-abutment designs must be used for bridges up to 60 m (197 ft) in length (90 percent of all new bridges in the United Kingdom are less than 60 m [197 ft] in total length).

The use of jointless bridges with integral abutments also is increasing in the United States. In some states, such as Tennessee, steel bridges are built with span lengths of up to 120 m (400 ft) with no joints, even at the abutments; and concrete bridges of this type are built with span lengths up to 240 m (800 ft). However, other states are reluctant to use this approach because of the lack of exact design methodologies.

MATERIALS AND SYSTEMS

The panel made the following observations about European bridge materials and systems. (The panel only visited

Northern Europe; perhaps in Southern Europe, where de-icing agent application would differ, materials and systems would also differ.)

Concrete Materials and Durability

In Europe, concrete mixes are designed with prime considerations given to durability—not strength. The Danish Road Directorate attempts to ensure more durable concrete through decreased permeability achieved by specifying certain ranges of ingredients. The effectiveness is verified through permeability tests. As a by-product, the concrete has greater strength than typically specified in the United States. In France, water-cement ratios of 0.40 to 0.45 are commonly used and, by using plasticizers, ratios as low as 0.35 are being contemplated.

In Denmark, Switzerland, and the United Kingdom, and, to a lesser degree in France, silica fume (also known as microsilica) and fly ash are used as supplementary cementitious materials in concrete.

The panel was told that German industry pressures building contractors into the use of fly ash, but bridge contractors are more cautious. The nature of the pressures was not explained. Standards to qualify fly ash are not readily available in Germany. Fly ash is only added to concrete when fine aggregates are lacking and additional fines are needed. If fly ash is used, the cement content is not reduced. In Germany, silica fume is not used in bridge construction.

Controlled permeability formwork (CPF)—which is designed to be permeable to air and water but not to cement particles—is used in Denmark and the United Kingdom to produce denser, more durable near-surface concrete. In the United Kingdom, the Department of Transport believes that all concrete should be high performance, and attempts are being made to improve the durability of formed concrete at the surface by reducing permeability. Zemdrain™ (a material manufactured by DuPont) is used as a formliner to allow excess air and mix water to escape in the vicinity of the forms, thus producing a dense, less permeable, hence more durable, concrete cover zone.

Until recently, concrete mixes for U.S. bridges were designed for strength with durability as the next consideration. Now, greater attention is being given to durability. CPF is not being used in U.S. bridge construction.

The panel encourages the FHWA to continue its ongoing research on high-performance materials and the development of concrete mixes that address durability concerns in bridge components and to sponsor projects to demonstrate the use of CPF to enhance the durability of near-surface concrete. The panel recommends that the NSF fund curriculum development to enhance the teaching of design for durability at U.S. universities and encourages the ABET to include design for durability among the criteria for evaluating engineering design curricula for accreditation.

Composite Materials

Although not yet commonplace, polymer-matrix composite materials are being used for strengthening both steel and concrete bridges, and as prestressing tendons in Switzerland, under the direction of Professor Urs Meier of the Swiss Federal Laboratories for Materials Testing and Research (Eidgenössische Materialprüfungs und Forschungsanstalt). In France, there has been little use of advanced composite materials. The beginning of use of advanced composite materials in the United Kingdom is demonstrated in the Bonds Mill Bridge (Figure 15). The 8.2-m (26.9-ft)-long bascule-span bridge is built over a canal linking the Severn and Thames rivers. Bridge engineers in the United Kingdom also are exploring non-metallic advanced composite materials for use as concrete reinforcement, post-tensioning tendons, and ducts.

Waterproofing

The European emphasis on bridge-deck waterproofing systems was one of the panel's significant observations. Concrete bridge decks are generally covered with a waterproofing layer or system.

The Danish Road Directorate prefers the multi-course waterproofing system shown in Figure 19 for bridge-deck protection. This system consists of the following layers applied in the following order:

- An epoxy-with-sand prime coat applied to the sand-blasted concrete deck;
- Two polymer-modified bitumen sheets, fully bonded to the concrete;
- A 15- to 20-mm (0.6- to 0.8-in.)-thick drain layer of open-graded asphalt concrete;
- A 40-mm (1.6-in.)-thick binder course of modified asphalt concrete; and
- A 40-mm (1.6-in.)-thick wearing course of asphalt concrete or stone mastic asphalt.

Figure 20 shows the prefabricated bitumen sheets being heated with an open flame, partially melting them, to bond them to the epoxy-primed concrete bridge deck and to other overlapping sheets.

Observing this rather elaborate deck protection system being installed on a monumental project such as the Great Belt raised the question as to the use of such systems on more routine bridges. On inquiry, the Danish Road Directorate indicated that such systems are installed on all bridges in Denmark. The deck protection or waterproofing system, in use and refined since the 1920s, is expected to, and usually does, provide a service life of 30 years with appropriate maintenance; however, the contractor is required to warrant the deck-protection system for 5 years.

The German Ministry of Transport uses a multi-course bridge-deck protection system similar to the Danish system



Figure 19. Danish multi-course waterproofing system on the Great Belt project.

of “gluing” bitumen layers directly to the concrete deck except that the open-graded asphalt concrete layer is not included. Previously, a vapor-pressure detention layer resulted in freeze-thaw problems. Despite limited experience, the Ministry expects 20 to 25 years of deck protection from the system. The German system costs approximately 100 to 120 DM/m² (\$6.90 to \$8.25 per ft²)—about 5 percent of the total bridge cost.

In France, all bridges receive waterproofing consisting of mastic asphalt, synthetic chemical resins—either epoxy or polyurethane, one of various proprietary systems of prefabricated sheets, or a proprietary system named “Etanplast.” Two types of mastic asphalt waterproofing are used. One type consists of an 8-mm (0.3-in.)-thick layer of naturally occurring bituminous limestone mixed with refined bitumen applied over a dry surface, cleaned and prepared with a tack

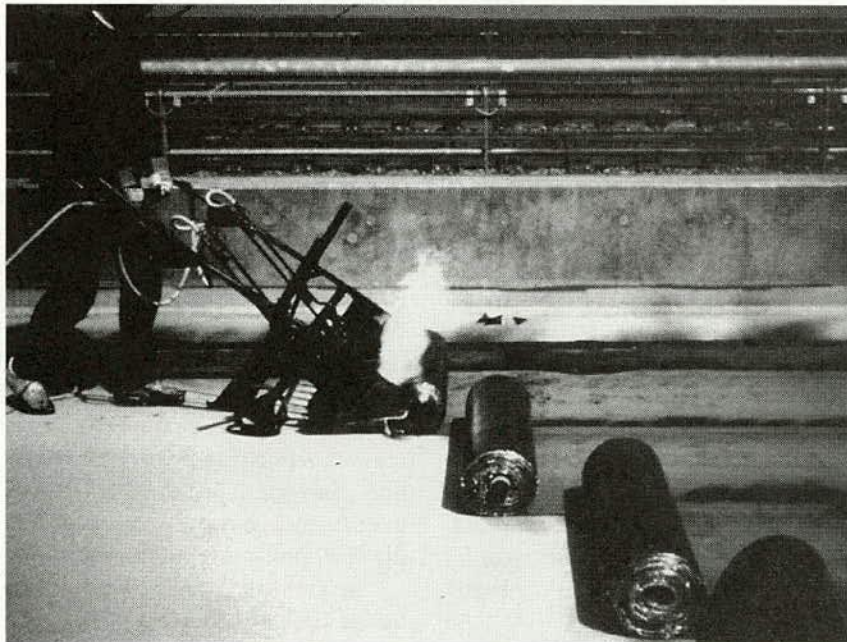

Figure 20. Bonding bitumen sheets to concrete bridge deck.

coat, followed by a 22-mm (0.9-in.)-thick layer of asphalt mixed with gravel. The other type consists of a layer of 4-mm (0.2-in.)-thick polymer asphalt mastic followed by a 26-mm (1-in.)-thick layer of asphalt and gravel. The prefabricated-sheet systems are similar to the waterproofing system observed in Denmark. The sheets consist of polymer-modified bitumen reinforced with non-woven polyester. The sheets are usually glued together by partial melting of the sheet or with a bonding layer of bitumen. Finally a layer of bituminous gravel mix is placed over the sheets before the wearing surface is applied. The Etanplast system consists of several layers applied in the following order:

- An elastomer-modified emulsion,
- A 15- to 30-mm (0.6- to 1.2-in.)-thick layer of bituminous concrete with small aggregate applied with a paver,
- A 2-mm (0.1-in.)-thick membrane of asphalt, and
- A layer of slate flakes to protect the membrane.

The wearing surface is applied over these layers.

Although the Germans anticipate a service life of 20 to 25 years for these systems, the proprietary systems have a warranty period of only 3 to 5 years. The Etanplast system is the one in which they have the most confidence, but it is impractical for smaller jobs because of the required equipment.

In France, the designer selects the waterproofing system with consideration to cost, time of installation, and engineer and contractor expertise. The approximate cost of all systems is 150 to 180 francs/m² (\$3.00 to \$3.60 per ft²) (significantly less than the quoted cost in Germany). No deck problems have been observed in France during the past 30 years that would warrant either partial or full-deck removal. This is attributed to the success of the waterproofing and the quality of the concrete. In the past, decks were built with non-air-entrained concrete and these have been severely damaged because of the freeze-thaw cycles.

In the United Kingdom, bridge decks are also waterproofed. To be considered for installation on concrete bridge decks, the systems must have a British Board of Agreement Certificate. The consultants may select from among several waterproofing systems.

The proprietary Stirling-Lloyd system, "Eliminator," seems to be used the most often in the United Kingdom. The Eliminator system is a two-coat, spray-applied, solvent-free, acrylic-resin-based system. It is easy to apply; however, it is also the most expensive.

The life expectancy of the various certified waterproofing systems is at least 20 years. The Eliminator system is expected to last 60 years. Recently completed research that examined 10- to 15-year-old bridges suggested that the waterproofing has thus far been successful. The Eliminator system was recently introduced into the United States, with applications to railroad bridges and a highway tunnel.

Other than a recently completed research effort in the United Kingdom, little, if any, in-service monitoring of

deck waterproofing systems is performed in the countries visited.

U.S. experience with waterproofing membranes is summarized in *NCHRP Synthesis of Highway Practice 220: Waterproofing Membranes for Concrete Bridge Decks*. Relevant points are as follows:

- In sharp contrast to Europe and Canada, waterproofing membranes are not widely used in the United States. Approximately 25 percent of the states reported some (although certainly not statewide) use of waterproofing membranes in new construction. Many more, about 50 percent of the states, use them in rehabilitation.
- Over the past two decades, the number of bridge owners using waterproofing membranes in new construction has declined sharply. This decline is attributed to increased use of epoxy-coated reinforcement to protect bridge decks.
- Owners hold vastly differing opinions as to the effectiveness of waterproofing membranes in protecting bridge decks. Most negative opinions reflect early, perhaps outdated, experiences.

Several U.S. jurisdictions, the State of Minnesota in particular, successfully use a low-slump concrete overlay developed by Iowa State University, as a waterproofing course. Minnesota credits this success to the specification of this overlay type on enough bridge projects to ensure that contractors acquire enough expertise to participate in these projects. *Because of the extreme contrasts between U.S. and European practice, the panel encourages the FHWA, NCHRP, or another research-funding agency to develop or undertake a study to evaluate the performance and cost-effectiveness of domestic and European deck waterproofing systems and their application to U.S. practice. NCHRP Synthesis of Highway Practice 220 is a good starting point for such a study.*

Epoxy-Coated Reinforcement

The confidence in the effectiveness of waterproofing systems and the quality of the concrete mixes has led to minimal use of epoxy-coated reinforcing bars in Europe.

For structural bridge elements other than decks, the Danish Directorate protects the reinforcing steel through the use of a dense concrete, with no use of epoxy-coatings of the reinforcement or the coating of concrete itself (epoxy-coated bars were however observed to be used in the Great Belt tunnel liners). No cathodic protection (CP) of prestressed-concrete girders is used (some very limited CP is used on bridge decks).

In Germany, protection of reinforcing steel consists merely of a clear concrete cover of 40 mm (1.6 in.), which the Ministry of Transport believes provides adequate protection. Previously, insufficient cover and lower concrete

quality (i.e., high permeability) resulted in corrosion problems. Neither epoxy-coated reinforcing bars nor special concrete mix designs (water-cement ratios of 0.50 are typical) are used.

In Switzerland, epoxy-coated reinforcing bars are used to a minor degree in bridge decks and some specialty structures. Earlier structures included concrete covers of 20 to 30 mm (0.8 to 1.2 in.). Today concrete cover is not less than 40 to 50 mm (1.6 to 2.0 in.).

In the United Kingdom, a different direction is being taken to avoid corrosion problems. The use of non-reinforced concrete is encouraged where possible (e.g., massive abutments without any reinforcing steel).

Epoxy-coated reinforcement is widely used in the United States. To a degree, the FHWA has mandated protection of bridge decks against corrosion on federal-aid projects. Epoxy-coated reinforcement is used in bridge decks (unprotected by European-style waterproofing membranes) and in other elements subject to the direct application of de-icing agents and vehicle-induced de-icing agent spray.

Corrugated Steel Webs

The Europeans have used corrugated steel webs on a few bridges, with both steel and concrete flanges.

In France, corrugated steel webs have been used on several bridges, including concrete bridges (i.e., concrete top and bottom flanges connected to corrugated steel webs with shear connectors) and steel space-frames with tubular lower flanges. In the case of steel girders, the perceived advantages include the use of thinner unstiffened webs. In the case of prestressed-concrete flanges, prestressing is not lost to the web because the corrugated plate resists little compression. Tests are underway to quantify the fatigue resistance of corrugated steel web details as no specifications exist.

Bridges with corrugated steel webs, with either steel or concrete flanges, have not yet been constructed in the United States; however, the concept is being investigated for domestic application. The FHWA is investigating the feasibility of corrugated steel webs as a part of its high-performance materials initiative. In this research, steel-bridge designs that use corrugated steel webs will be developed and those issues that must be addressed in order to proceed with a demonstration project will be identified. The American Iron and Steel Institute is also examining the concept of corrugated steel webs for steel-concrete composite bridge designs. Design concepts will be developed in this research.

No domestic data on the fatigue of corrugated web-to-flange weld exist. Fatigue-resistance experts believe that this resistance must be bounded by the AASHTO fatigue Categories B and C.

Domestic steel-bridge fabricators believe that girders with corrugated webs can be fabricated using current technology if the corrugated web proves to be cost-effective.

The panel encourages the FHWA to continue its ongoing research on high-performance materials and investigate the use of corrugated steel webs in steel and prestressed-concrete girders, with consideration to fatigue resistance, constructability, and economic viability.

Superstructure Enclosure Systems

In the United Kingdom, fiber-reinforced plastic (FRP) under-deck superstructure enclosure systems have been developed. These permanent, but removable, enclosures form a cocoon around the bridge superstructure to provide a corrosion-inhibiting environment. In addition, the enclosures provide a platform on which inspectors can gain access to otherwise inaccessible components. Research by the Department of Transport has projected that the corrosion rate of uncoated steel in the protected environment within the bridge enclosure is about 2 to 10 percent of that for painted steel in the open. Bridge enclosures of conventional materials will be used on the Second Severn Crossing; however, the Maunsell Group has proposed the use of FRP enclosures for conventional steel cross sections and in conjunction with a space-frame superstructure as a complete system.

Use of an under-deck bridge enclosure on an existing steel bridge that already has exhibited corrosion problems could solve an environmentally sensitive problem by eliminating the need to remove lead-based paint. However, corrosion may continue, albeit at a slower rate.

Superstructure enclosure systems are not in use in the United States. However, the U.S. aluminum industry recently has suggested the use of aluminum enclosures.

In light of the level of protection against corrosion suggested in the United Kingdom, the panel recommends that the FHWA sponsor projects to demonstrate the use of under-deck superstructure enclosures, of either FRP or conventional materials.

Coating Systems

The Europeans are using innovative coating systems for structural steel, in the form of paints and metallizing.

The Germans indicated that, because their newer coating systems for steel are more successful, they regard concrete and steel bridges as equal in terms of maintenance effort and costs. The most significant technological advance in painting systems cited by the German bridge engineers was the application of coatings in the shop. Because coatings for steel also are shop-applied in the United States, the increased longevity of German systems relative to those of the United States is perhaps attributable to differences in coating formulations, more familiar to coatings experts than bridge experts.

In the United Kingdom, paint systems are being regulated by the defense department for quality control/assurance and industrial secrecy and were reported to be performing well.

Aluminum metallizing also has been used on some bridges as an external coating.

The panel encourages the FHWA to sponsor investigations to evaluate innovative painting and metallizing systems, as part of its ongoing research on high-performance materials.

Grouted, Post-Tensioned Concrete

In September 1992, the United Kingdom placed a moratorium on the construction of grouted post-tensioned concrete bridges. This moratorium, still in effect, is the result of the December 1985 failure of the Ynys-y-Gwas bridge and subsequent inspections of other post-tensioned concrete bridges, which revealed evidence of improper grouting of post-tensioned tendon ducts. This improper grouting results in corrosion of the tendons.

Concerns about the performance and durability of grouted post-tensioning is limited to the United Kingdom and was not observed or cited in the other countries visited. During the early 1970s, when the rest of Europe was tightening specifications for post-tensioned concrete bridge design, U.K. engineers were involved in extensive research into steel-box-girder bridges subsequent to the failure of several bridges of this type. Consequently, post-tensioned construction as practiced most recently in the United Kingdom reflected specifications developed in the late 1960s. The Ynys-y-Gwas bridge was constructed in 1953 and employed tendon duct grouting techniques that are now outdated. Although of interest because of potential improvements that may result from new U. K. research, the panel does not believe that the

present moratorium on grouted post-tensioned construction in the United Kingdom is indicative of a pervasive European problem.

Grouted post-tensioned construction has been in use in the United States for more than 40 years. Experience regarding the durability of grouted post-tensioned concrete bridges has been generally favorable. The California Department of Transportation (Caltrans) has constructed many grouted post-tensioned concrete bridges and, in conjunction with the Post Tensioning Institute, has promulgated information about proper grouting techniques. A recently published report by the American Segmental Bridge Institute also highlights the good performance of U.S. segmental concrete bridges, many of which contain grouted post-tensioning tendons. Thus, in contrast to the U.K. experience, the U.S. experience with grouted tendons has been extremely positive.

Given that current research and investigations in the United Kingdom may lead to general improvements in grouting specifications, the panel recommends that the FHWA evaluate the procedures developed in the United Kingdom (when available) and determine if a technical advisory should be issued to disseminate the findings to U.S. engineers and owners.

Bridge Railings

In Denmark and Germany, the panel observed a redundant system of bridge railing in typical use. In Denmark, a cable system is installed in the outer edge rail to serve as a fail-safe mechanism. Figure 21 is a photograph of such a system on

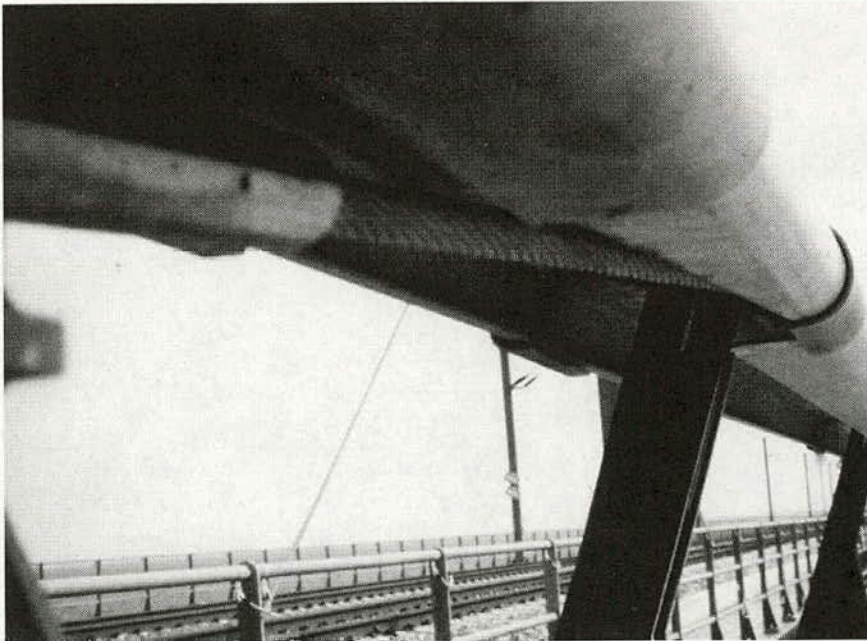

Figure 21. Bridge railing on the Great Belt West project.

the Great Belt West Bridge. Double bridge railing systems consisting of supplemental structure-mounted railings about 1.0 m (3.0 to 4.0 ft) behind the primary barrier, as shown in Figure 22, are used in Germany. Further, development of bridge-railing crash testing standards is underway in Germany.

PRODUCTION, FABRICATION, AND ERECTION PROCESSES

The following are the observations made by the panel relating to European material production, bridge fabrication, component-assembly, and erection.

Quality Control

The Europeans design for service lives that are far longer than those that Americans design for. Thus, they emphasize life-cycle cost considerations, and consequentially, material quality, specification rigor, and contractor workmanship. They accept the increase in the initial construction cost because of this high quality standard.

All of the countries visited cited the durability achieved through quality in the field. European bridge designers expect the contractor to provide a high level of quality in the field and, therefore, do not develop specifications and provisions that assume a low minimum quality level. The Europeans expect and believe that they achieve a high level of workmanship quality in field.

The U.S. competitive bid system requires contractors bidding on a project to meet minimum acceptable quality levels if awarded the contract. If required, and if compensation is provided, U.S. contractors could provide the same high level of quality as European contractors.

Erection Methods

Europeans use incremental launching for bridge construction extensively. Incremental launching was chosen for the Löwenberg Viaduct in Switzerland because of economics and efficiency, although the bridge could have been built on falsework. In France, incremental launching of steel bridges has been done with and without the deck slab in place. The process is controlled to keep cracks in concrete to a width of 0.2 mm (0.01 in.) or less by calculation. In the United Kingdom, entire short-span steel bridges are shop fabricated (with concrete decks poured in the shop) and shipped to the job site to be set by large cranes. This method is used primarily to avoid traffic problems, as is the incremental launch method, and its use is increasing.

In the United States, incremental launching is used primarily for unique bridges. Generally, bridges are erected in place.

Thermo-Mechanical Process Control

Among the French innovations relating to bridge steels is the use of thermo-mechanical process control (TMPC) tech-



Figure 22. Redundant bridge railings on the Mosel Valley Bridge in Germany.

niques for tapered rolled plate production. French steel companies produce rolled steel plates with different thicknesses and intermediate strength (e.g., yield strength of 460 MPa [67 ksi]) using TMPC. The TMPC steel has high toughness and requires no preheating for welding. This process is being investigated as part of the FHWA's high-performance steel initiative, by the American Iron and Steel Institute.

The panel encourages the FHWA to continue investigating TMPC for steel production as part of its ongoing research on high-performance materials.

BRIDGE MANAGEMENT SYSTEMS, INSPECTION, AND EVALUATION

Bridge Management Systems

Apparently, the development and enhancement of European bridge management systems are progressing more slowly than in the United States. The Danish Road Directorate uses the DANBRO bridge management system, a proprietary system developed by an American company. In Switzerland, a system based on the Pontis bridge management system is being developed.

Although made optional under the National Highway Designation Act of November 1995, most state DOTs are continuing to implement bridge management systems to prioritize bridge projects. Most DOTs are using Pontis, an AASHTO-developed bridge management system; some are using BRIDGIT, developed by NCHRP; and others, such as Pennsylvania, have developed their own systems.

Inspection Practices

European bridge inspection programs involve detailed and often frequent inspections.

In Denmark, three types of inspections are carried out. The principal inspection (similar to U.S. biennial inspections) is performed every 1 to 6 years, depending on the condition of the bridge, the traffic level, and known extent of damage. Special inspections are carried out occasionally when damage has been observed or is suspected. Routine inspections are performed anywhere from daily up to once a week; an extended routine inspection is performed every 6 months.

In Germany, the state personnel inspect the bridges. The inspection program consists of four levels of inspection—cursory visual inspections performed every 3 months, simple inspections performed every 3 years, thorough main inspections (similar to U.S. biennial inspections) performed every 6 years, and special inspections (usually done by consultants) performed to assess damage.

In France, the inspection program follows a 1979 guideline. Two classes of inspections (regular and special) are performed. Regular inspections include the frequent visual inspections performed by regional and local government per-

sonnel whenever they cross the bridge; annual inspections of bridges with spans greater than 10 m (33 ft), which are performed by engineers with the aid of technicians but without the use of special tools; and periodic detailed inspections (performed at intervals of less than 5 years by specialists) for important or large bridges. Special inspections may include initial detailed inspections after completion of construction, inspections before expiration of the 10-year warranty, and more in-depth inspections for known problems. The special inspections may require instrumentation that can indicate the existence of problems that require bridge closure. The inspections also may involve detailed inspection of individual components, structural analysis, or both. Bridge inspection specialists are in the seven technical engineering centers (Centre d'Etudes Techniques de l'Equipe [CETE]) and in SETRA. They also work with the 17 regional LCPCs.

Bridge inspections in the United Kingdom include a "look see" (the term used by the panel's hosts in the United Kingdom) performed daily by employees; general inspections performed every 2 years; principal inspections (similar to the U.S. biennial inspections), which are detailed inspections performed at 6- to 10-year intervals and scheduled in coordination with the network manager of the region; and special inspections, performed to assess damage caused by an overload, a flood, or other occurrence. Inspectors take normative deterioration diagrams into the field so they have a standard for comparison.

Bridge inspectors in the United Kingdom do not receive formal training. In Austria and Germany, bridge inspectors enhance their knowledge through formal training, conferences, and interaction with designers. Special guidelines and rules for inspection of grouted post-tensioned bridges are now available in the United Kingdom.

Some European countries are highly conscious of inspectability and maintainability of expansion dams, bearings, and other structural elements requiring periodic replacement and maintenance. In the United Kingdom, elimination of bridge joints is recommended; however, if a joint is provided, access to the joint must be provided for inspection. They feel that the decks are well protected, but joint leakage is a problem; therefore, the joint must be accessible to inspectors.

The FHWA requires that state DOTs inspect their bridges at least every 2 years as stipulated in the National Bridge Inspection Standards.

Nondestructive Evaluation Devices

A French-developed high-energy-radiation, nondestructive evaluation device is being used to detect voids in post-tensioning ducts and fractured wires. The device, known as "Scorpion," uses a linear particle accelerator to generate high-energy X-rays. It is mounted on an arm with a reach of 8 m (26 ft) and a longitudinal travel of 7 m (23 ft) and can

penetrate thicknesses up to 1,400 mm (55 in.). Scorpion can detect voids in grout of post-tensioning ducts and fractures in strands, but cannot detect corrosion.

The United Kingdom has borrowed Scorpion and used it to a limited extent to detect voids, but it could not be used in urban areas because of the radiation emissions.

Because of health and safety concerns, high-energy-radiation nondestructive evaluation devices are not used in the United States. In general, the public and worker safety and health standards seem more stringent in the United States than in Europe and potential stray radiation emissions from such devices would not be permitted.

Because the top surfaces of concrete bridge decks in Europe are covered by waterproofing systems, techniques were developed to measure corrosion potentials from below. For example, half-cell mapping of the underside of the deck in conjunction with measurements of humidity and temperature is used in Switzerland to determine chloride penetration and corrosion potential. Cores are taken to determine chloride content.

MAINTENANCE PRACTICES

The following are the observations made by the panel relating to European bridge maintenance practices.

Traffic Flow Considerations

Maintenance and protection of traffic during rehabilitation are primary concerns in Europe. Instead of planning bridge maintenance separately from highway maintenance as is typically done in the United States, Europeans plan maintenance of bridges along with the highways that encompass them. In Germany, all maintenance work on a given stretch of roadway is performed during periods of light demand (i.e., not during the summer vacation periods). This practice is acceptable to the motorist public and keeps their enthusiasm and support for their transportation infrastructure.

The Europeans have discovered that single-box cross sections are difficult to maintain and repair without hindering traffic. In the case of concrete box girders, the Europeans stated that where transverse prestressing is used in the top flange of concrete box girders, it is easier to maintain traffic on the bridge if the cross section consists of two boxes rather than a large single box. If deck repairs to a single-cell box are necessary, the whole bridge must be closed to traffic, whereas, in the case of two single-cell boxes, only half the bridge must be shut down and traffic is diverted to the other half. Swiss engineers are moving away from single-box-girder bridges, such as the Felsenau Bridge, toward the use of twin-box girder bridges.

In the United States, a typical bridge cross section has multiple redundant longitudinal members. For major new bridges, however, there appears to be a trend away from single large boxes. For example, the Figg Engineers Group newer cable-stayed bridge designs (e.g., the James River Bridge in Virginia and the Chesapeake and Delaware Canal Bridge in Delaware) are twin boxes rather than single-box designs such as that typified by their earlier Sunshine Skyway Bridge across Tampa Bay. As in Europe, maintenance and protection of traffic are primary concerns during bridge rehabilitation.

Bridge Washing

Some of the countries visited wash de-icing agents and other contaminants from their bridges annually.

The Danish Road Directorate washes bridges after every winter with a low-pressure water blast to rinse off residual de-icing agents and thereby reduce possible corrosion damage. In Switzerland, the bridges are washed twice a year.

Since the failure of the Mianus River Bridge along I-95 in Connecticut (because of corrosion exacerbated by moisture trapped by debris), Professor John W. Fisher of Lehigh University has advocated the practice of washing bridges periodically with low-pressure water, as from a fire engine. This technique is being used by only a few jurisdictions in the United States.

CHAPTER 3

RECOMMENDATIONS

On the basis of the observations made during the scanning review, the panel made 18 recommendations for pursuit by public and private agencies. These recommendations, grouped into high- and medium-priority items, follow.

HIGH-PRIORITY RECOMMENDATIONS

- A research-funding agency (e.g., the FHWA, NCHRP, or other organization) should develop or undertake a study to evaluate those U.S. and European project-delivery systems that could be applied in the U.S. cultural environment and recommend potential changes (including parallel mandates, design competitions, design-build, and design-build-maintain and operate concepts) as appropriate.
- The FHWA should continue its ongoing high-performance materials research initiative and investigate European practices designed to emphasize quality, durability, and aesthetics during all stages of bridge engineering and construction (e.g., concrete mixes designed for durability, TMPC for steel production, and innovative paint systems and metallizing).
- Bridge owners should support innovation by taking the concept of partnering one step further as a “proof of concept.” Sharing responsibility among owners, designers, and contractors would facilitate the development of new concepts for bridge design and construction.
- A research-funding agency (e.g., the FHWA, NCHRP, or other organization) should develop or undertake a study evaluating the performance and cost-effectiveness of U.S. and European deck waterproofing systems.
- Bridge owners should consider increased funding for routine maintenance.
- The AASHTO Highway Subcommittee on Bridges and Structures should develop bridge-rating specifications that reflect the latest design specifications.
- A research-funding agency (e.g., the FHWA, NCHRP, or other organization) should develop or undertake a study reevaluating European-style contractor warranties for compatibility with the U.S. legal system, particularly in light of the recent relaxation of regulations by the FHWA.

MEDIUM-PRIORITY RECOMMENDATIONS

- A research-funding agency (e.g., the FHWA, NCHRP, or other organization) should develop an informational package promoting public awareness of how bridge and highway investment benefits the United States.
 - The AASHTO Highway Subcommittee on Bridges and Structures (perhaps through the NCHRP) should review and participate in the Eurocode development.
 - The FHWA should develop projects demonstrating the use of under-deck superstructure enclosures to retard corrosion.
 - The FHWA should develop projects demonstrating the use of three-dimensional steel or steel-concrete composite space-frame superstructures.
 - The FHWA should develop projects demonstrating the use of concrete formliners designed to enhance the durability of near-surface concrete, such as Zembrain™.
 - The FHWA should evaluate procedures being developed in the United Kingdom for grouting full prestressed, longitudinally post-tensioned concrete bridges and, if warranted, prepare a technical advisory to disseminate the information, developed as a result of the United Kingdom’s experience with improper grouting.
 - Bridge owners should consider peer review for the design of major or unusual bridges.
 - The NSF should fund curriculum development to enhance U.S. universities’ teaching of design for durability.
 - State DOTs and the FHWA should give aesthetics more consideration when evaluating bridge projects.
 - The FHWA should continue its ongoing high-performance material research initiative and its investigation of the use of corrugated steel webs for use in steel girders and as webs of prestressed-concrete girders, with emphasis on fatigue resistance, constructability, and economic viability for domestic bridges.
 - The FHWA should prepare a technical advisory recommending field testing to destruction of decommissioned bridges previously designated for demolition and replacement.
-

APPENDIX A

PANEL MEMBERS

The panel consisted of representatives from U.S. federal, state and private-sector agencies, associations, and academia. Information about panel members follows.

Dr. Walter Podolny, Jr., Panel Co-Chair, is Chief of the Bridge Review and Design Branch, Bridge Division, Office of Engineering, Federal Highway Administration (FHWA), in Washington, D.C. In this position, he exercises full managerial and technical responsibility for the review and approval of major, unusual, and complex fixed and movable bridges, tunnels, and related structures. Dr. Podolny has more than 24 years of experience in bridge design.

Mr. James E. Siebels, Panel Co-Chair, is the Chief Engineer for Design and Construction for the Colorado Department of Transportation in Denver, Colorado. Mr. Siebels is responsible for the design and construction of highways and bridges for the Department. Prior to his current assignment, Mr. Siebels had more than 20 years of experience in bridge design and construction. He is serving as the Chairman of the Highway Subcommittee on Bridges and Structures of the American Association of State Highway and Transportation Officials (AASHTO).

Ms. Laurinda T. Bedingfield is the Commissioner of the Massachusetts Highway Department in Boston, Massachusetts. In this position, she oversees inspection of the Commonwealth's 5,000 bridges, as well as their repair and replacement averaging more than \$100 million yearly. Commissioner Bedingfield has a geotechnical engineering background with an expertise in foundation design, including development of subsurface investigation programs, field inspection, and analysis and design of lateral support systems and foundations.

Mr. Fred R. Beckmann is the Director of Bridges for the American Institute of Steel Construction (AISC) in Chicago, Illinois. In this position, he represents the steel fabrication industry in all matters relating to steel bridge construction. Mr. Beckmann has more than 30 years of experience in steel bridge fabrication and associated activities.

Ms. Nancy McMullin Bobb is the Division Bridge Engineer for the California Division of the FHWA, in Sacramento, California. In this position, she is responsible for the federal oversight of the California bridge program which includes bridge design, construction and maintenance, as well as the development and implementation of innovative technologies. Ms. Bobb has been with the FHWA for 12

years as a specialist in the bridge area and has worked on several bridge design and construction projects in various parts of the United States, including Colorado; Washington, D.C.; and Kansas.

Mr. Donald J. Flemming is the State Bridge Engineer and Director of the Office of Bridges and Structures, Engineering Services Division of the Minnesota Department of Transportation in St. Paul, Minnesota. In this position, he is responsible for managing bridge and structure design and providing general guidance for bridge construction and maintenance in Minnesota. Mr. Flemming, who has 34 years of experience with the Department of Transportation and 27 years of experience in bridge design, construction and maintenance activities, is representing AASHTO.

Mr. Arthur Hamilton is the Regional Administrator, FHWA, in the four-state region of Iowa, Kansas, Missouri, and Nebraska. Mr. Hamilton is responsible for providing leadership, direction, and coordination with local, state, and federal officials on the cooperative Federal/State Highway Program in Region Seven. He has more than 20 years of experience in bridge design, construction, and maintenance.

Mr. David J. Hensing is the Deputy Executive Director of AASHTO in Washington, D.C. His current duties include serving as staff liaison to the Association's Highway Subcommittee on Bridges and Structures. As a professional engineer and senior Association official, Mr. Hensing's areas of interest include standards and standard setting, bridge management systems, research needs, and broad transport policy issues.

Dr. John M. Kulicki is Senior Vice President and Chief Engineer of Modjeski and Masters, Inc., of Harrisburg, Pennsylvania. In this position, he recommends technological direction for the firm and leads design projects, such as the Second Blue Water Bridge between Port Huron, Michigan, and Point Edward, Ontario, Canada, under construction. Dr. Kulicki has 30 years of bridge experience; has led design projects involving girder, truss, arch, and cable-stayed bridges; and recently led the team that wrote the *AASHTO LRF Bridge Design Specifications* adopted in 1994. Dr. Kulicki is representing the American Road and Transportation Builders Association (ARTBA).

Mr. Charles Lewis is the Deputy Commissioner of the Georgia Department of Transportation in Atlanta, Georgia. In this position, he works directly for the Commissioner of

Transportation and is responsible for the administration of the state agency. Mr. Lewis has more than 23 years in bridge design, is the former State Bridge Design Engineer, is the former Chief Engineer for the Georgia Department of Transportation, and is representing AASHTO.

Dr. Dennis R. Mertz is an Associate Professor of Civil Engineering at the University of Delaware in Newark, Delaware. His research at the university involves: design methodologies, fatigue and fracture of steel bridges, and the rehabilitation of steel bridges using advanced composite materials. Prior to joining the University of Delaware, Professor Mertz was an Associate with the bridge design firm of Modjeski and Masters, Inc., and was Co-Principal Investigator on the research project that developed the *AASHTO LRFD Bridge Design Specifications*.

Mr. David M. Moskowitz is a principal owner of A. G. Lichtenstein and Associates, Inc., a private consulting engineering firm specializing in bridge design, with offices throughout the United States and its corporate offices in Paramus, New Jersey. In this position, he is responsible for the firm's design of new, and rehabilitation of existing, fixed and movable highway and railroad bridges throughout the northeastern and north central regions of the United States. Mr. Moskowitz has more than 33 years of bridge design experience and is representing private engineering firms via the American Consulting Engineers Council (ACEC).

Mr. M. G. Patel is the Chief Bridge Engineer and Director of the Bureau of Design for the Pennsylvania Department of Transportation, in Harrisburg, Pennsylvania. He is responsible for developing bridge standards and design criteria, bridge safety inspection, and engineering software. He is also responsible for highway design environmental clearance, right-of-way and utility clearance, photogrammetry and surveys, and letting and awarding of construction contracts. Mr. Patel has more than 26 years of experience in bridge design and inspecting and is representing AASHTO.

Mr. Ernst Petzold is the National Marketing Principal (Bridges) for Sverdrup Civil, Inc., with headquarters in St. Louis, Missouri. He is responsible for the marketing of bridge services throughout the United States and provides technical input for complex bridge projects. Mr. Petzold,

who has been involved in the design of long-span bridges for more than 20 years (having worked on truss, orthotropic girder, segmental concrete, and cable-supported structures) is representing the ACEC.

Dr. Basile G. Rabbat is the Manager of Transportation Structures and Structural Codes for the Portland Cement Association (PCA) in Skokie, Illinois. He is responsible for highway and transit programs, for the development and modification of codes and specifications related to concrete structures, and, since 1984, serves as Secretary to American Concrete Institute (ACI) Committee 318, Standard Building Code. Dr. Rabbat has more than 25 years of experience related to testing, analysis, and design of concrete structures and is representing the concrete industry.

Dr. Robert J. Reilly is the Director of the Cooperative Research Programs Division of the TRB, a unit of the National Research Council in Washington, D.C. He is responsible for management of the NCHRP, a contract research program funded at approximately \$17 million annually. Dr. Reilly has more than 35 years of experience in design, construction, and materials engineering and research in government, the private sector, and academia.

Mr. Louis N. Triandafilou is the Regional Director, Office of Structures, for the FHWA's Region 3 Office in Baltimore, Maryland. In this position, he is responsible for administering programs, policies, and procedures, including assistance to FHWA Division, state, and local government agency personnel in planning, design, construction, maintenance, inspection, and research of bridges, tunnels, culverts, and other highway structures. Mr. Triandafilou has more than 20 years of experience related to bridge construction, inspection, maintenance, management, research, and design.

Mr. Frank E. Ward is the Chairman of the Board of F. E. Ward, Inc., a construction company specializing in the building and rehabilitation of bridges, with its main office in Vancouver, Washington. In this position, he is responsible for the company's operations at sites west of the Rocky Mountains and Alaska. Mr. Ward has been involved in bridge construction in all capacities—from construction supervisor to his current position—during the past 28 years and represents the Associated General Contractors of America (AGC).

APPENDIX B

ITINERARY

Panel members met with bridge owners, consultants, contractors, and academics from Denmark, Germany, Switzerland, France, and the United Kingdom. In each country, panel members visited in-service bridges and bridges under construction. Their itinerary follows:

			France	25 June 1995	Panel Mid-Review Meeting
				26 June 1995	Roads and Highways Engineering Department
Denmark	18 June 1995	Panel Meeting Road Directorate of the Danish Ministry of Transport		27 June 1995	Public Works Central Laboratory and represen- tatives from private practice
	19 June 1995	Road Directorate of the Denmark Ministry of Transport and Storebælt		28 June 1995	Roads and Highways Engineering Department
Germany	20-21 June 1995	Federal Ministry of Transport	United Kingdom	29 June 1995	Highways Agency of the Department of Transport and repre- sentatives from private practice
Switzerland	22 June 1995	Swiss Federal Institute of Technology		30 June 1995	Maunsell Group
	23-24 June 1995	Swiss Federal Highways Office		1 July 1995	Panel Post-Review Meeting

THE TRANSPORTATION RESEARCH BOARD is a unit of the National Research Council, which serves the National Academy of Sciences and the National Academy of Engineering. It evolved in 1974 from the Highway Research Board, which was established in 1920. The TRB incorporates all former HRB activities and also performs additional functions under a broader scope involving all modes of transportation and the interactions of transportation with society. The Board's purpose is to stimulate research concerning the nature and performance of transportation systems, to disseminate the information that the research produces, and to encourage the application of appropriate research findings. The Board's program is carried out by more than 400 committees, task forces, and panels composed of more than 4,000 administrators, engineers, social scientists, attorneys, educators, and others concerned with transportation; they serve without compensation. The program is supported by state transportation and highway departments, the modal administrations of the U.S. Department of Transportation, and other organizations and individuals interested in the development of transportation.

The National Academy of Sciences is a private, nonprofit, self-perpetuating society of distinguished scholars engaged in scientific and engineering research, dedicated to the furtherance of science and technology and to their use for the general welfare. Upon the authority of the charter granted to it by the Congress in 1863, the Academy has a mandate that requires it to advise the federal government on scientific and technical matters. Dr. Bruce M. Alberts is president of the National Academy of Sciences.

The National Academy of Engineering was established in 1964, under the charter of the National Academy of Sciences, as a parallel organization of outstanding engineers. It is autonomous in its administration and in the selection of its members, sharing with the National Academy of Sciences the responsibility for advising the federal government. The National Academy of Engineering also sponsors engineering programs aimed at meeting national needs, encourages education and research, and recognizes the superior achievements of engineers. Dr. William A. Wulf is interim president of the National Academy of Engineering.

The Institute of Medicine was established in 1970 by the National Academy of Sciences to secure the services of eminent members of appropriate professions in the examination of policy matters pertaining to the health of the public. The Institute acts under the responsibility given to the National Academy of Sciences by its congressional charter to be an adviser to the federal government and, upon its own initiative, to identify issues of medical care, research, and education. Dr. Kenneth I. Shine is president of the Institute of Medicine.

The National Research Council was organized by the National Academy of Sciences in 1916 to associate the broad community of science and technology with the Academy's purpose of furthering knowledge and advising the federal government. Functioning in accordance with general policies determined by the Academy, the Council has become the principal operating agency of both the National Academy of Sciences and the National Academy of Engineering in providing services to the government, the public, and the scientific and engineering communities. The Council is administered jointly by both Academies and the Institute of Medicine. Dr. Bruce M. Alberts and Dr. William A. Wulf are chairman and interim vice chairman, respectively, of the National Research Council.

Abbreviations used without definitions in TRB publications:

AASHO	American Association of State Highway Officials
AASHTO	American Association of State Highway and Transportation Officials
ASCE	American Society of Civil Engineers
ASME	American Society of Mechanical Engineers
ASTM	American Society for Testing and Materials
FAA	Federal Aviation Administration
FHWA	Federal Highway Administration
FRA	Federal Railroad Administration
FTA	Federal Transit Administration
IEEE	Institute of Electrical and Electronics Engineers
ITE	Institute of Transportation Engineers
NCHRP	National Cooperative Highway Research Program
NCTRP	National Cooperative Transit Research and Development Program
NHTSA	National Highway Traffic Safety Administration
SAE	Society of Automotive Engineers
TCRP	Transit Cooperative Research Program
TRB	Transportation Research Board
U.S.DOT	United States Department of Transportation

Transportation Research Board
National Research Council
2101 Constitution Avenue, N.W.
Washington, D.C. 20418

ADDRESS CORRECTION REQUESTED

NON-PROFIT ORG
US POSTAGE
PAID
WASHINGTON, D.C.
PERMIT NO. 8970