

# Failure of a Geogrid-Reinforced Soil Wall

RICHARD J. BATHURST AND DANIEL J. BENJAMIN

The construction and testing of a large-scale reinforced soil wall 3 m high built within the Royal Military College Retaining Wall Test Facility is discussed. The wall was constructed to retain a sand fill and comprised full-height (propped) panel facings and four layers of a relatively weak geogrid. The weak geogrid was chosen so that the wall could be failed under surcharge. Following construction the wall was stage loaded by applying a series of increasing surcharge loads up to 80 kPa pressure. Each load was sustained for a minimum of 100 hr to observe creep in the composite system. The wall was heavily instrumented to record displacements along the grid layers, grid strains, connection loads, panel deformations, toe forces, and vertical earth pressures. Test results indicated that during the final surcharge increment a well-defined failure plane was generated through the reinforced soil mass and was followed some days later by (creep) rupture of the reinforcement. Large strains in the grid layers were observed in the vicinity of the connections that were comparable in magnitude to the peak strains recorded at the location of the observed failure plane in the reinforced soil mass. Finally, important implications are drawn concerning the design and construction of those systems.

A research program has been underway for several years at the Civil Engineering Department of the Royal Military College (RMC) of Canada that is concerned with monitoring full-scale geosynthetic-reinforced soil walls to acquire a comprehensive set of physical data from carefully constructed and monitored reinforced soil wall models. The data can be used to understand better the complex behavior of those systems and to guide the development of physically correct analytical methods for the design and construction of those generic structures.

To date, 10 full-scale model walls have been tested in the RMC Retaining Wall Test Facility. Variables between tests have included the facing treatment (i.e., incremental panels, propped panels, wrap around) and the geogrid reinforcement type (strong, weak). Results of several of those tests have been reported by the authors and coworkers in previous publications (1-4).

This paper reports the results of a recent test on a full-height (propped) panel wall that was heavily instrumented and then taken to failure under uniform surcharging. The scope is restricted to presentation of some of the test data and identifies qualitative features of model behavior of interest to those involved in the design and analysis of propped wall structures.

## RMC RETAINING WALL TEST FACILITY

Full-scale geosynthetic reinforced wall tests have been performed in the RMC Retaining Wall Test Facility located within the structures laboratory of the Civil Engineering Department. The principal structural components of the test facility are illustrated in Figure 1, and an overview of the test facility is presented in Figure 2. The test facility comprises six reinforced concrete counterfort wall segments used to confine a block of soil approximately 6.0 m long by 2.4 m wide by 3.6 m high. The modules are anchored to the structural floor of the laboratory by a series of anchor bolts that pass through the center of each counterfort. Those bolts also provide the reaction for cross beams that contain an air bag surcharging system used to apply a uniform vertical pressure to the surface of test configurations. This current surcharging arrangement allows a maximum uniform pressure of 100 kPa to be applied to the soil surface. The inside walls of the modules are lined with Plexiglas over plywood and covered by three sheets of lubricated polyethylene sheeting. The results of shearbox tests modeling the sidewall/sand interface give a fully mobilized friction angle of less than 15 degrees. Three-dimensional stability calculations indicate that the contribution of the test facility sidewalls to model stability is less than 15 percent of the total active force that would otherwise act in a true plane-strain condition (5).

Mechanical response of retaining walls reinforced with polymeric materials is dependent on a large number of variables related to soil properties, facing type, quality of construction, loading conditions, and environmental conditions (principally temperature). A major advantage of the RMC Retaining Wall Test Facility is that those variables can be controlled and, hence, the influence of specific variables (such as grid type and facing type) on wall performance can be isolated.

## PROPPED WALL TEST CONFIGURATION

A full-height propped panel wall model was constructed in the RMC Retaining Wall Test Facility with the general arrangement indicated in Figure 3. The wall was supported by a series of external props until the soil behind the panels was placed to the full height of the wall (3.0 m). The wall facings comprised a central panel 1 m wide and two 0.7 m-wide edge panels. The central panel was manufactured from aluminum and was instrumented. The edge panels were constructed out of timber and were used to further isolate the

R. J. Bathurst, Civil Engineering Department, Royal Military College of Canada, Kingston, Ont., Canada K7K 5L0. D. J. Benjamin, Base Construction Engineer Officer, CFB Valcartier, Que., Canada.

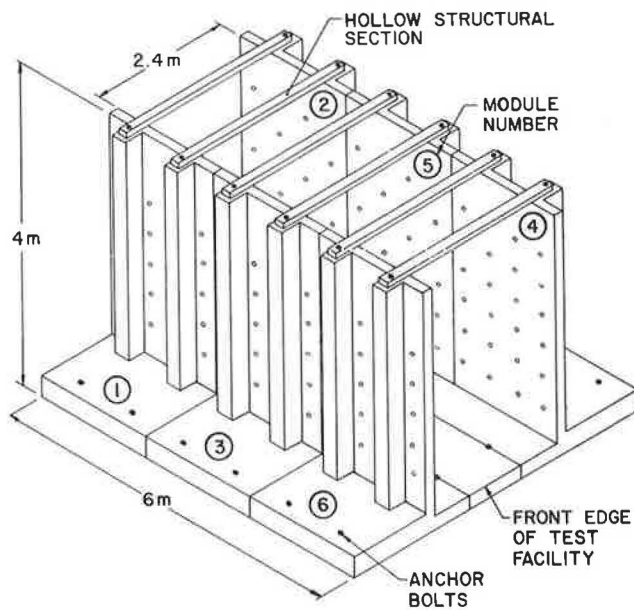

FIGURE 1 RMC retaining wall test facility.

central instrumented section of the model from the influence of sidewall friction.

The geosynthetic reinforcement comprised a Tensar Geogrid SS1 oriented in the weak direction. Grid geometry is illustrated in Figure 4, and some properties are listed in Table 1. The grid is a biaxial-oriented grid with polypropylene as the constituent material and is relatively weak and extensible and would not be used in a field installation. The choice of this grid was dictated by a desire to be able to fail the reinforced soil system with the surcharging capacity at hand. In some of the first model walls constructed at RMC, layers of Tensar Geogrid SR2 were used as the reinforcement. SR2 is relatively stiff and strong and is routinely specified by the manufacturer for this purpose. However, full-scale models constructed with SR2 reinforcement did not develop significant strain, and, consequently, wall behavior at incipient failure could not be studied (1).

The propped wall in the current investigation was constructed with four layers of SS1 spaced at 0.75-m intervals. The grid layers were trimmed to widths conforming to center and edge panel dimensions, and each layer extended 3 m into the retained soil. The grid spacing and lengths represent a standard geometry that has been adopted in all wall models constructed to date in the RMC facility. The initial grid arrangement has not been modified to make fair comparisons between tests with a variety of facing treatments and grid type.

The soil in all wall tests has been a uniformly graded washed sand with some fine gravel (Figure 5). The average bulk density as compacted is about  $1.8 \text{ Mg/m}^3$  and is usually placed at a moisture content of 1 to 3 percent. The results of large-scale shearbox tests have indicated that the material has a peak (secant) friction angle that varies from  $\phi = 56$  degrees at a confining pressure of about 10 kPa to  $\phi = 43$  degrees at a normal stress of 120 kPa (6). The high strength of the sand is considered to be caused by the high angularity of the constituent sand particles. This material would be considered an

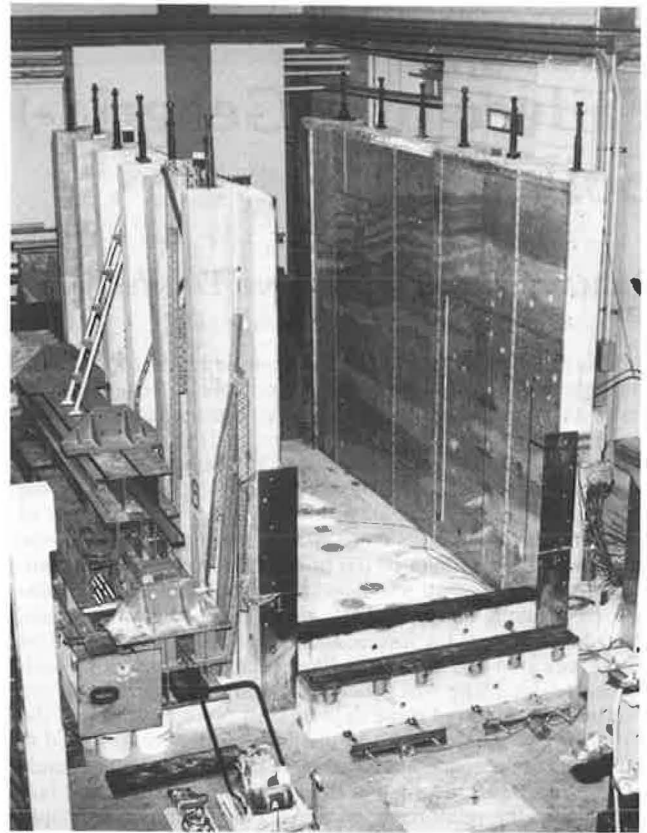

FIGURE 2 Overview of RMC retaining wall test facility.

ideal material in a field application owing to its high friction angle, permeability, and ease of compaction.

## CONSTRUCTION AND SURCHARGING

The central and edge panels were mounted on a leveling pad used to model the strip footing used in field applications to support and align the facing units. The panels were pinned at the base and supported by external props until the full depth of soil behind the wall was placed and compacted. The sand soil was placed and compacted in 125-mm lifts. Each grid was lightly pretensioned before placement to remove, as far as practical, any warps or slackness in the reinforcement. External props and facing units were not perfectly rigid, and approximately 6 mm of outward movement at the top of the wall was recorded as a result of sand placement and compaction before prop release.

A series of uniform surcharge pressure increments were applied to the retained soil following removal of the props. The fill placement history and surcharging schedule for the propped panel wall test is presented in Figure 6. Surcharge increments were typically left on for a period of 100 hr to observe creep in the wall structure and in the polymeric reinforcement. As is indicated on the figure there were two unplanned unload/load cycles during the final 80 kPa surcharging increment that were the result of power outages.

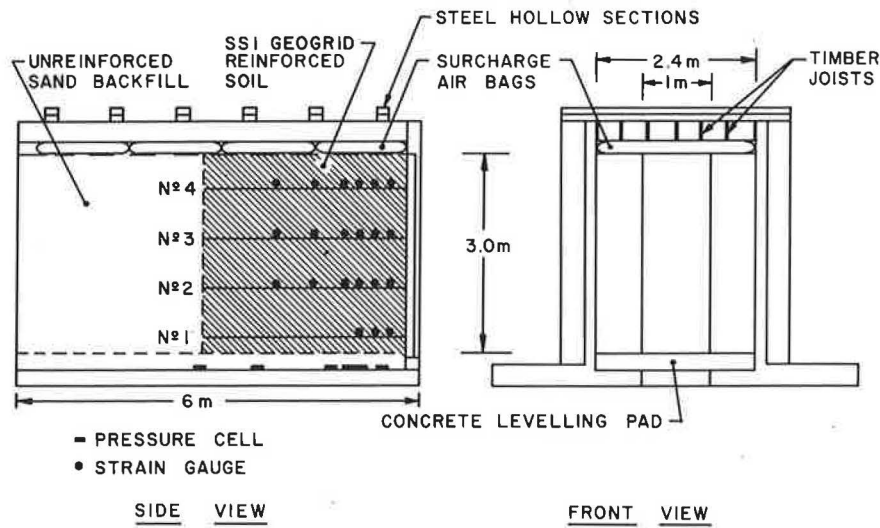

FIGURE 3 General arrangement for propped full-height panel wall test.

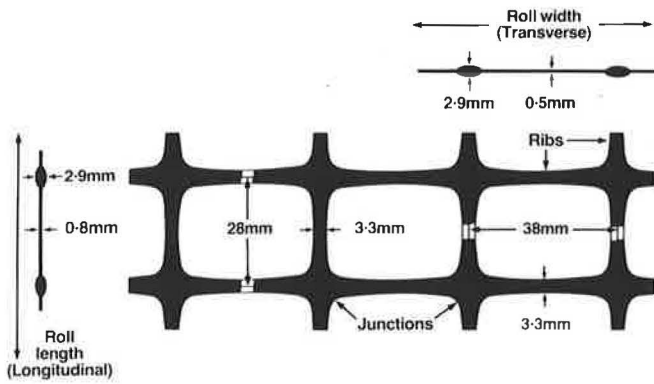

FIGURE 4 Tensar Geogrid SS1 (from Netlon Ltd. 1984).

TABLE 1 MECHANICAL PROPERTIES OF TENSAR SS1 GEOGRID REINFORCEMENT

Orientation	Stiffness (kN/m) (@ 2% strain)	Peak Load (kN/m)	Strain @ Peak Load (%)
transverse (strong)	292	20	14
longitudinal (weak)	204	12	14

\*Manufacturers Literature/ ASTM D4595 Wide Width Strip Tensile/Elongation Test SS1 oriented in weak direction

**INSTRUMENTATION**

The following measurements were taken to monitor the performance of the propped wall during construction, surcharging, and at failure:

1. Horizontal movements of the instrumented central panel,
2. Reinforcement displacements and strains,

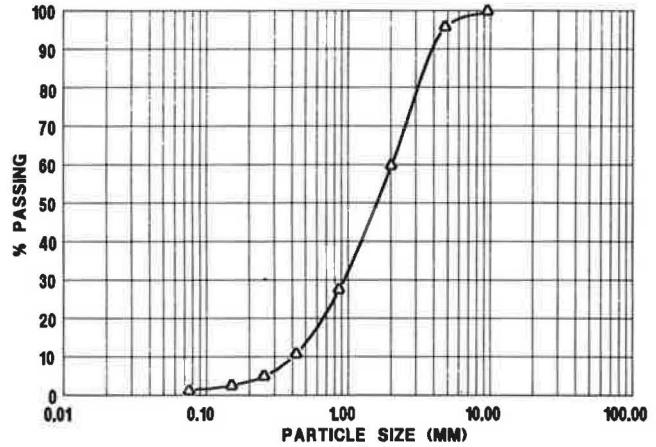

FIGURE 5 Grain size distribution for RMC sand.

3. Loads at the toe of the wall and at panel/grid connections, and

4. Vertical earth pressures at the base of the reinforced soil mass and in the vicinity of selected grid layers.

Details of instrumentation, calibration, and interpretation of readings from many RMC trial walls are reported in a companion paper by the first author (7).

**TEST RESULTS**

**General**

Obvious signs of wall behavior can be associated with outward movements of the central monitored wall facing panel. In this test, outward wall movements were observed to match the application of each new load increment (see Figure 7). Further, as the magnitude of load level increased, the rate of time-dependent movement was observed to increase. Finally,

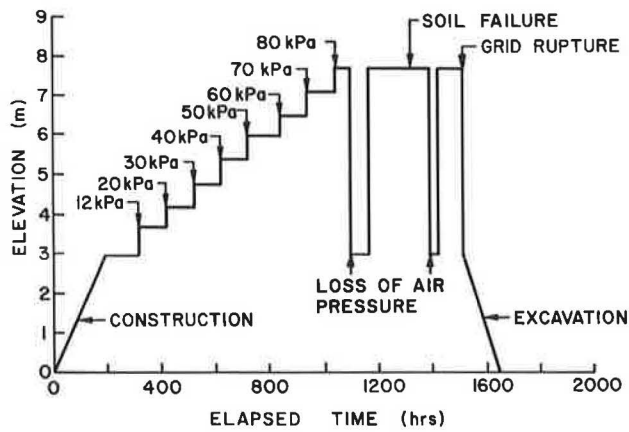

FIGURE 6 Construction and surcharging history.

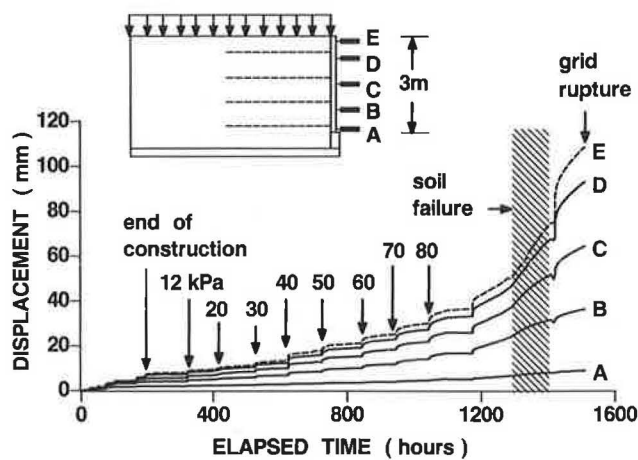

FIGURE 7 Panel displacements.

between the time of the two unload/load cycles during the final 80 kPa surcharge increment, evidence of a soil-to-soil failure through the reinforced soil mass occurred manifest as the simultaneous damage of several pieces of instrumentation embedded in the reinforced soil mass and accelerated deformation rates in displacement recording devices. Several days after the final 80 kPa reloading episode the sound of tearing grid could be heard over a period of 28 hr, signaling imminent collapse of the structure. At this point the surcharge was removed to protect the array of instrumentation at the wall face from damage. Removal of the surcharging system at the top of the model wall revealed a failure scarp at the surface of the reinforced soil mass approximately 1 m behind the panel wall. The surface of the slumped soil mass was observed to have dropped approximately 65 mm. Careful excavation of the soil behind the wall indicated that grid layer 4 was ruptured over about 80 percent of its width at the panel connection, indicating that collapse of the wall was likely minutes away when the test was terminated. Further excavation and removal of the facing panels revealed the internal failure surface (traced on Figure 8) and is believed to be that generated during the final 80 kPa surcharge increment. The failure surface has a geometry corresponding to a log-spiral shape, but, from prac-

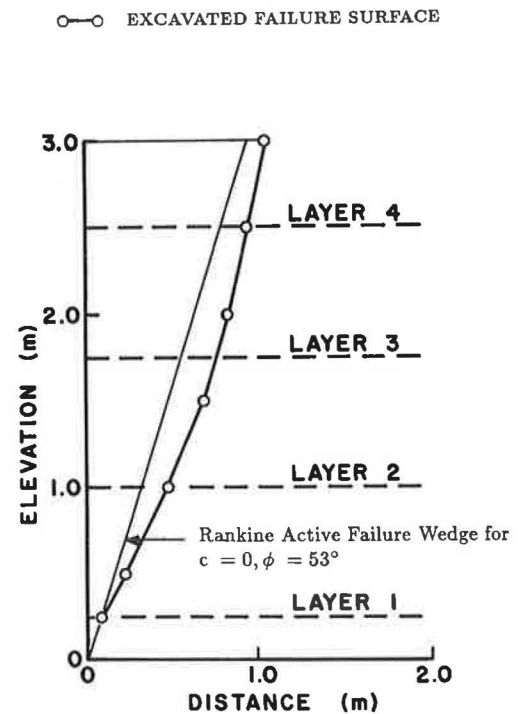

FIGURE 8 Excavated soil failure surface.

tical considerations, the volume of failed soil can be approximated by considering a Rankine wedge of soil commencing at the toe of the wall (based on representative soil strength parameters of  $c = 0$  and  $\phi = 53$  degrees). The geometry of the volume of failed soil is similar to that reported by the authors from the results of an unreinforced wall test used to calibrate the test facility for edge effects (5). Under the heavy surcharging conditions applied to this relatively short panel wall the initial failure mechanism can be represented by a wedge of soil as if the reinforcement was not present.

#### Panel and Grid Movements

The central facing panel profile at intervals during the propped wall test is presented in Figure 9. As was expected, the wall rotated outward from the pinned base of the panels as surcharging was applied. Relatively larger incremental deformations occurred during the 70 and 80 kPa surcharge stages. The lack of curvature at the top of the wall at the end of the test was considered to be due to the almost complete rupture of grid layer 4. The maximum vertical out-of-alignment at prop release was about 8 mm, about 14 percent of the movement recorded at soil failure.

Horizontal displacements recorded by extensometers on the grid layers and interpolated panel movements opposite the grid layers are summarized in Figure 10 for grid layer 4. The sensitivity of panel movements to surcharge loading can be seen in this figure for reinforcement layer 4 and was also apparent from similar data taken from the other grid layers. The figure also indicates a series of sudden minor jumps in grid displacements under constant surcharge load, suggesting a "stick-slip" type of load-transfer mechanism between grid and

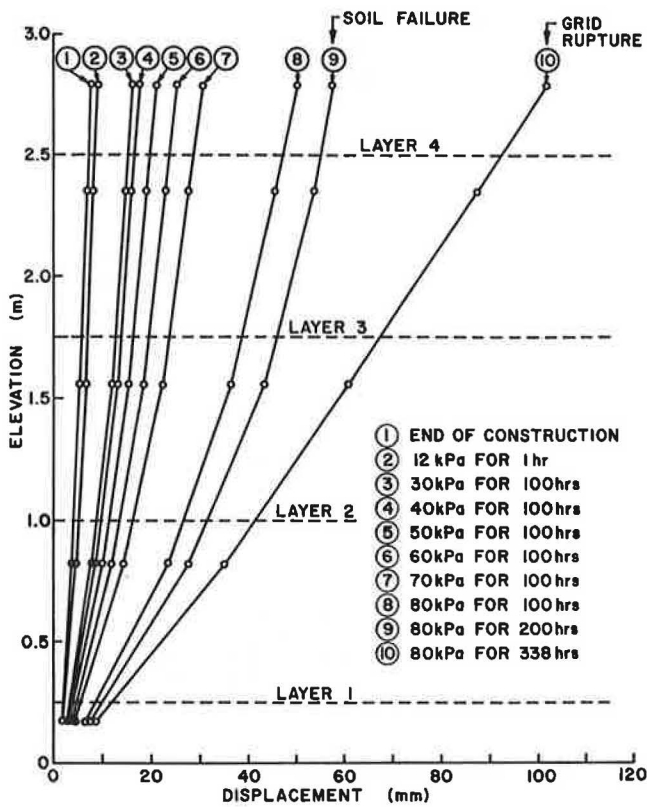

FIGURE 9 Panel displacement profiles.

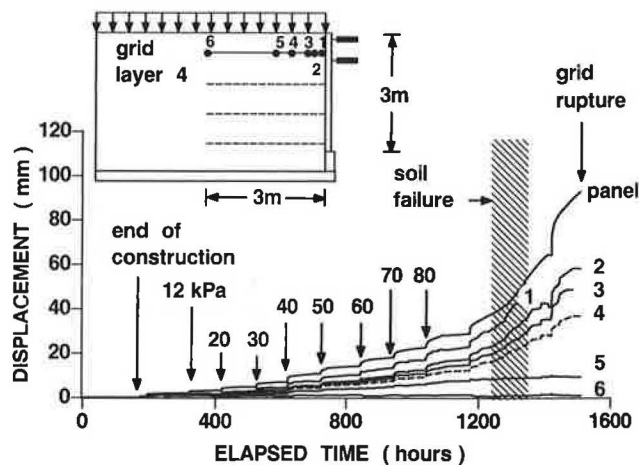

FIGURE 10 Example of grid displacements.

soil. The unload sequences were not planned but do indicate that the grid deformations (and panel movements) were irrecoverable and that elastic deformations in layer 4 were negligible when compared to the plastic deformations that had accumulated during the 80 kPa surcharge. Soil failure is believed to have occurred between the two 80 kPa surcharge reload episodes because during this period grid deformations were observed to accelerate and several pieces of equipment including extensometer 1 on grid layer 4 and a number of Bison

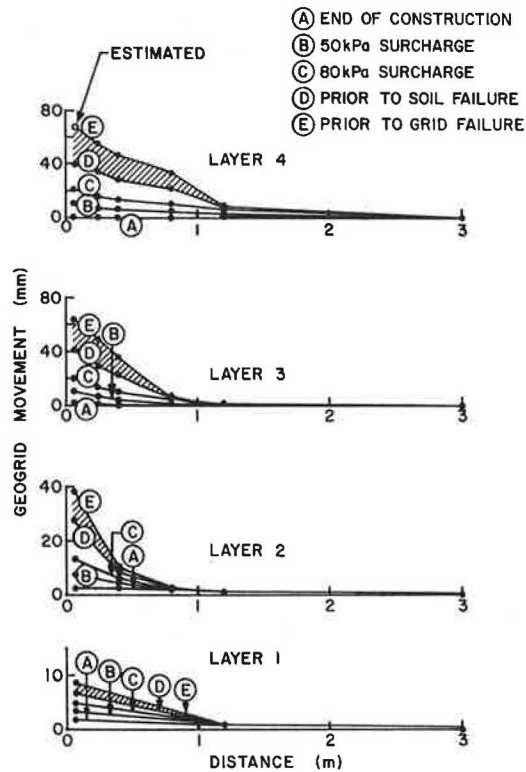

FIGURE 11 Summary of horizontal grid displacements.

inductance coils embedded in the soil were damaged. Grid deformations are summarized for all layers in Figure 11. The shaded portions in the figure represent the range of grid deformation in each layer during which soil failure is believed to have occurred. Extensometers attached to the free end of the grid layers did not record any displacements. In fact the figure shows that grid-to-soil load transfer in this test was restricted to less than 1.5 m into the reinforced soil mass. Consequently, the 3-m lengths employed in this model appear unnecessarily long for anchorage purposes.

**Grid Strains**

Grid strain profiles at selected times during the propped wall test are summarized in Figure 12. Strains in excess of 2 percent strain were calculated from the array of extensometers attached to the reinforcement and lower magnitudes of strain from strain gauges bonded directly to the grid (7). If the 50-kPa surcharge increment is considered to be a working load condition, then strains in the grid at working load levels are less than 2 percent and the largest strains occur at the connections. However, at incipient failure, strains were estimated to be as high as 10 to 12 percent at the connection in layer 4 (based on panel movement) and about 8 percent at similar locations on grids 2 and 3. The estimated strain at the connection for grid layer 4 is consistent with the rupture strain inferred from load-strain-time mechanical properties of virgin samples of the Tensar Geogrid SS1. However, a second region of locally

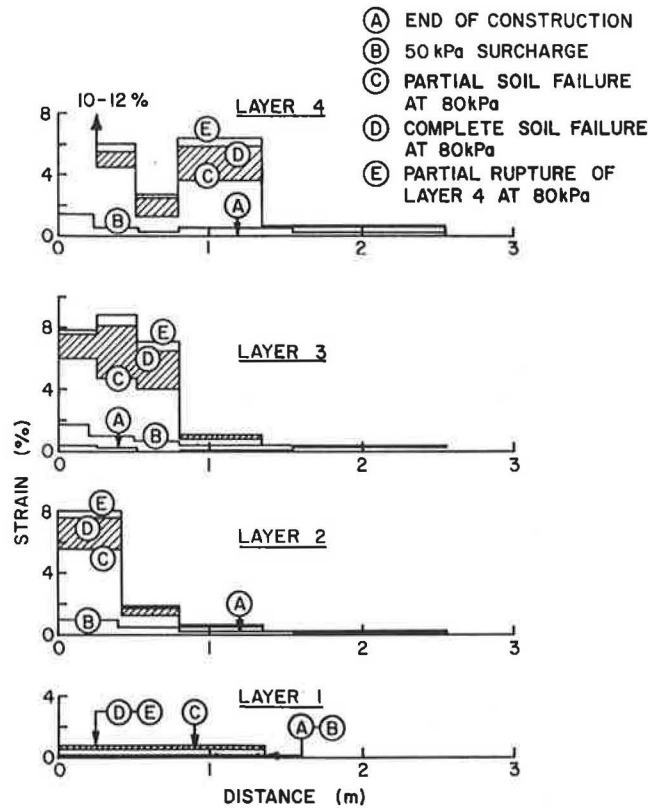

FIGURE 12 Summary of grid strains.

high strains (6 percent) was observed in layer 4 that matches the soil-to-soil failure plane revealed during excavation of the soil wall (Figure 8). The region of high strain in layer 3 extending to about 0.8 m into the reinforced soil mass can also be considered to be due to the combined effect of high connection strains and anchorage strains associated with a deep-seated failure surface that intersected grid layer 3 at about this location. The relatively short length of elevated grid strains suggests that under the given test conditions the grid anchorage length associated with lateral restraint of the failure wedge is very short (i.e., less than 0.5 m). The trend toward high grid strains at the panel connections has been observed in previous tests with propped panel construction performed by the authors and coworkers at RMC by using stiffer Tensar SR2 as the reinforcement (1,7) and is thought to be due to the reinforced soil mass behind the wall moving down relative to the panel, which is fixed in the vertical direction. This is particularly evident by the 65-mm drop in soil surface observed directly behind the panels at wall excavation. Consequently, a membrane effect is generated in the grid behind the wall where vertical earth pressures are transferred to the locally unsupported grid and then to the panel facing.

**Panel Forces**

The horizontal component of tensile grid forces transferred to the central monitored panel were recorded by using a series of proving rings. The proving rings were mounted on the face of the panels but were connected to the grid by stainless steel

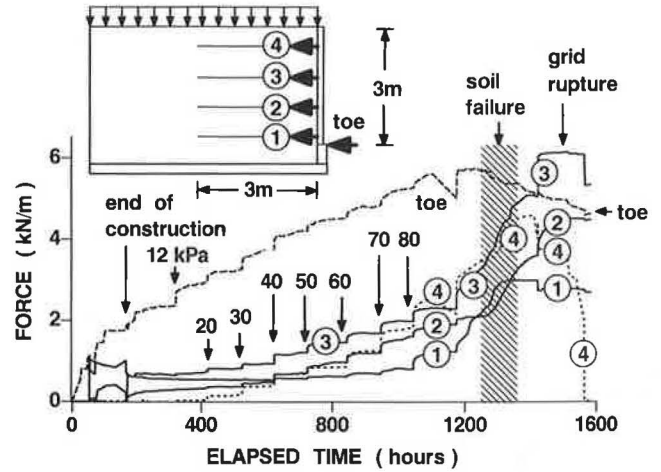

FIGURE 13 Grid connection forces.

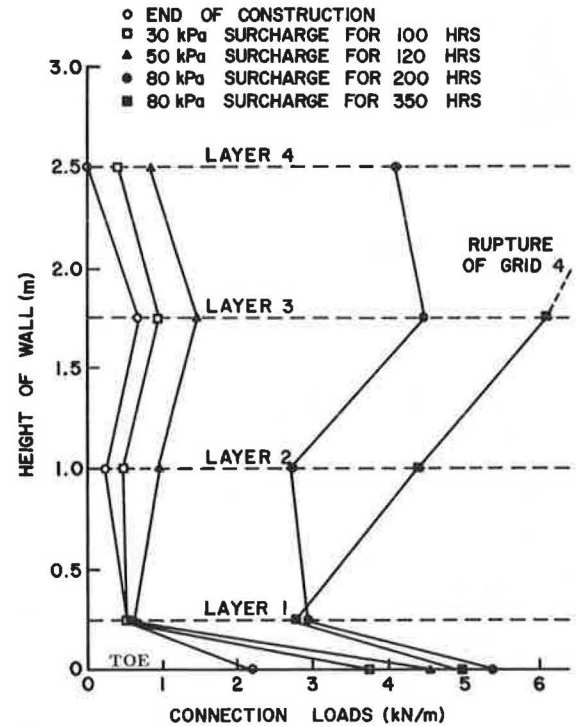

FIGURE 14 Summary of grid connection forces.

rods passing through a bushing arrangement built into the aluminum panels (7). The horizontal component of grid connection forces is presented in Figure 13. The data on the figure show that after soil failure there was evidence of load-shedding from grid 4 to grid layers 2 and 3 as the topmost layer was strained to rupture.

Horizontal connection forces are summarized on Figure 14 at selected times in the test program. At the end of the 50-kPa surcharge increment the grid connection forces were reasonably constant but the connection loads were increased in the two topmost layers as failure was approached. The data highlight the difficulty of simply scaling the magnitude of

lateral earth pressures determined at soil or wall collapse to arrive at the distribution and magnitude of pressures assumed to act under working load conditions as is routinely done in conventional limit-equilibrium-based methods of design. Also on Figures 13 and 14 is the measured horizontal toe force recorded at the base of the panel that was significant at all stages in the test program. The relatively stiff restraint offered by the pinned base of the wall may account for load attenuation in grid layers 1 and 2 at the latter stages of the test. Equivalent lateral earth pressures calculated from grid strains in the vicinity of the observed internal failure plane at incipient collapse of the wall are plotted on Figure 15. The horizontal toe force and the connection force in layer 1 have been added and the grid forces have been determined from isochronous load-strain-time data for the polymeric reinforcement. Superimposed on the figure are distributions based on active Rankine earth pressure theory ( $c = 0, \phi = 53$  degrees). It is reasonable to say within experimental error that the trend of constant lateral earth pressures is evident in the measured data but the magnitude of earth pressures is overestimated by Rankine theory (even when sidewall friction is considered).

The vertical component of base force was determined from an array of load cells supporting the full height panels. The results of those measurements indicated that the vertical forces were about 25 kN/m in magnitude during the final surcharge increment, equivalent to about 30 percent of the surcharge load applied to the top of the failed wedge of soil. From a practical point of view, toe force measurements indicate that at working load levels and at incipient collapse the rigid leveling pad can be considered to be at least equal to a layer of grid for purposes of translational stability of the facing panel. In addition, a significant portion of the vertical force acting on the potential failure wedge under the heavy surcharging is taken by the base of the wall. The additional restraint offered to the reinforced soil mass at the base of the wall is not considered in conventional methods of design for those structures.

**Vertical Earth Pressures**

The magnitude of vertical earth pressures over the course of construction and surcharging was determined by using six earth pressure cells cast into the base of the test facility and Glotzl cells placed in the vicinity of grid layer 3. All earth pressure cells were calibrated in situ by determining the response of each cell based on the first meter of soil compacted in place over the instrument during construction of the wall. The results of base pressure measurements are summarized on Figure 16. In general, the vertical earth pressures are reasonably well estimated considering the self-weight of the retained soil, its height, and the magnitude of the applied surcharge. The important exception to this case occurs in the vicinity of the panel toe where significant stress reduction was observed at the end of the test within about 0.5 m of the leveling pad. This observation is consistent with the membrane effect identified earlier that leads to vertical stresses being passed to the panels through the constrained panel/grid connections. The reduction in vertical stress integrated over a 0.5-m width is roughly equivalent to the magnitude of vertical force recorded by load cells mounted at the base of the wall. A uniform

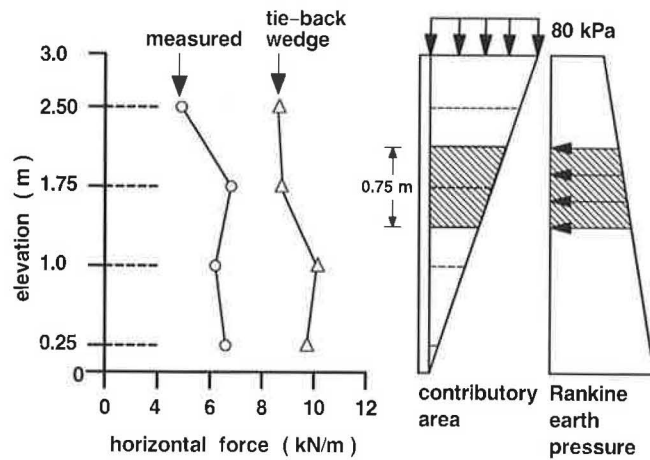

**FIGURE 15** Apparent lateral earth pressures.

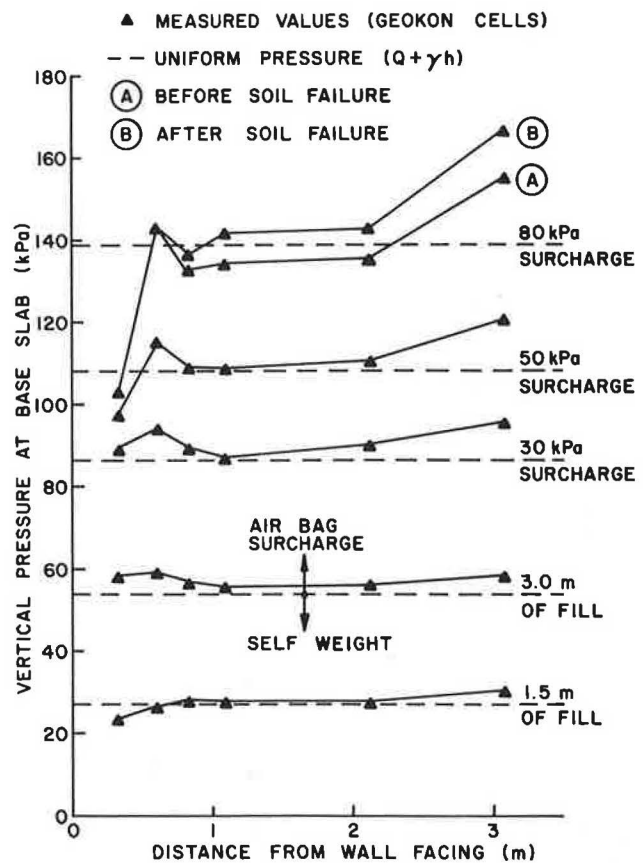

**FIGURE 16** Vertical earth pressures at base of reinforced soil.

pressure distribution is reasonable for those walls if vertical toe loads are considered in the manner just discussed.

The membrane effect was examined further by plotting earth pressures generated by Glotzl cells placed one lift (125 mm) below grid layer 3 (Figure 17) close to the back of the panel. The measured pressures are plotted with the uniform pressure distribution on the basis of depth and unit weight of the soil and surcharge magnitude. The same general trend in

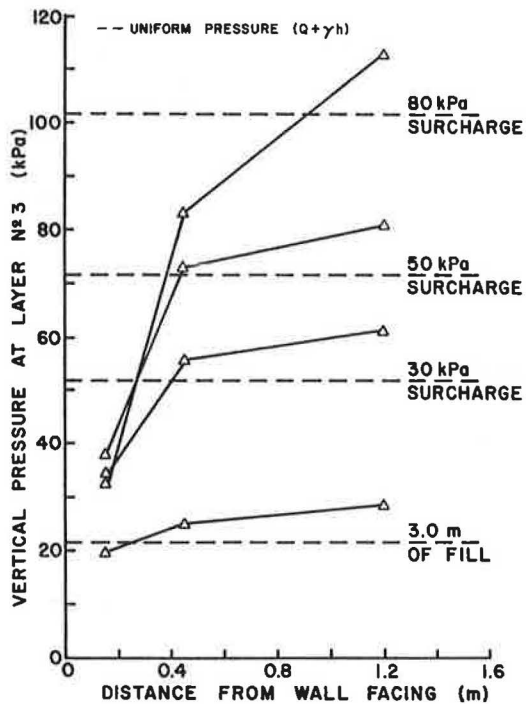

FIGURE 17 Vertical stresses below grid layer 3.

vertical stresses as recorded for the base pressure cells is apparent, but the losses are somewhat greater. The Glotzl cells were 125 mm below the grid and the base pressures cells were about 500 mm below grid layer 1.

### CONCLUDING REMARKS

The distribution of strains and panel toe loads observed in this and other similar tests performed by the authors has important implications to tie-back wedge methods of analysis. In a previous test reported by the authors (2), using the same grid and surcharging arrangement but an incremental panel wall construction, the magnitude of grid strains in the vicinity of the internal soil failure surface at the end of the test were of similar magnitudes in layers 2, 3, and 4 (i.e., 4 to 6 percent). In the current test it can be argued that within the margins of experimental accuracy strains are also of a similar magnitude at the location of the internal failure surface during the last surcharging increment. Tensile grid forces in layers 2, 3, and 4 may be similar and the grids may attempt to equilibrate tensile loads. If the test geometry and surcharging conditions represent a field case, then from an analysis point of view it may be useful to combine the horizontal toe force with grid layer 1 and to assume that each grid layer carries equal horizontal load in restraining the potential internal failure wedge at incipient failure.

Test results have indicated that the vertical restraint offered by the wall toe is also significant and is consequently an additional restraining mechanism that assists in the stability of those systems. Nevertheless, vertical toe capacity is not routinely considered in limit-equilibrium methods of analysis.

The results of this test and previous similar tests reported by the authors and coworkers have highlighted the impor-

tance of connection forces in the grid at all stages up to failure in those walls. Propped panel walls are common for geosynthetic-reinforced soil retaining wall systems. However, the effect of relative panel/soil movements is not normally considered in the design of those structures even though the results of the tests have indicated that the highest grid loadings occur at the grid/panel connections and that consequently this is the likeliest location for grid rupture in a field installation. In the model wall tests reported here special attention was paid to minimize the size and extent of the void that is inevitably formed below the connection during fill placement and compaction. In several field installations the level of attention to this detail has been observed by the authors to be less and it can be expected that the potential for the highest grid forces to occur at the connections is even more certain as the grid acts as a (unsupported) membrane in the vicinity of connection.

### ACKNOWLEDGMENTS

The authors would like to express their appreciation to P.M. Jarrett and J. Bell and J. DiPietrantonio who have assisted in the successful pursuit of this research program. The authors are also indebted to Tensar Corp. and Netlon Ltd. for provision of reinforcement materials. The funding for the work reported in the paper was provided by the Department of National Defence (Canada).

### REFERENCES

1. R. J. Bathurst, W. Wawrychuk, and P. M. Jarrett. Laboratory Investigation of Two Large-scale Geogrid Reinforced Soil Walls. In *The Application of Polymeric Reinforcement in Soil Retaining Structures*, (P. M. Jarrett and A. McGown, eds.) NATO Advanced Study Institutes Series, Kluwer, 1987.
2. R. J. Bathurst, D. J. Benjamin, and P. M. Jarrett. Laboratory Study of Geogrid Reinforced Soil Walls. In *Geosynthetics for Soil Improvement*, (A. D. Holtz, ed.) ASCE Special Publication 18, 1988, pp. 178-192.
3. R. J. Bathurst, P. M. Jarrett, and S. R. Lescoutre. An Instrumented Wrap-Around Geogrid Reinforced Soil Wall. *Proc., 3rd Canadian Symposium on Geosynthetics*, Waterloo, Ontario, Oct. 4, 1988.
4. R. J. Bathurst, D. J. Benjamin, and P. M. Jarrett. An Instrumented Geogrid Reinforced Soil Wall. *Proc., 12th International Conference on Soil Mechanics and Foundation Engineering*, Rio de Janeiro, Brazil, Aug. 1989.
5. R. J. Bathurst and D. J. Benjamin. Preliminary Assessment of Sidewall Friction on Large-Scale Models in the RMC Test Facility. In *The Application of Polymeric Reinforcement in Soil Retaining Structures*, (P. M. Jarrett and A. McGown, eds.) NATO Advanced Study Institutes Series, Kluwer, 1987.
6. R. A. Jewell. Analysis and Predicted Behaviour for the Royal Military College Trial Wall. In *The Application of Polymeric Reinforcement in Soil Retaining Structures*, (P. M. Jarrett and A. McGown, eds.) NATO Advanced Study Institutes Series, Kluwer, 1987.
7. R. J. Bathurst. Instrumentation of Geogrid-Reinforced Soil Walls. In *Transportation Research Record 1277*, TRB, National Research Council, Washington, D.C., (in press).