



**Innovations Deserving
Exploratory Analysis Programs**

High-Speed Rail IDEA Program

Smart Sensor System for Monitoring Railcar Braking Systems

Final Report for High-Speed Rail IDEA Project 51

Prepared by:
Darrell Socie
Christopher Barkan
University of Illinois at Urbana-Champaign

June 2008

TRANSPORTATION RESEARCH BOARD
OF THE NATIONAL ACADEMIES

INNOVATIONS DESERVING EXPLORATORY ANALYSIS (IDEA) PROGRAMS MANAGED BY THE TRANSPORTATION RESEARCH BOARD

This investigation was performed as part of the High-Speed Rail IDEA program supports innovative methods and technology in support of the Federal Railroad Administration's (FRA) next-generation high-speed rail technology development program.

The High-Speed Rail IDEA program is one of four IDEA programs managed by TRB. The other IDEA programs are listed below.

- NCHRP Highway IDEA focuses on advances in the design, construction, safety, and maintenance of highway systems, is part of the National Cooperative Highway Research Program.
- Transit IDEA focuses on development and testing of innovative concepts and methods for improving transit practice. The Transit IDEA Program is part of the Transit Cooperative Research Program, a cooperative effort of the Federal Transit Administration (FTA), the Transportation Research Board (TRB) and the Transit Development Corporation, a nonprofit educational and research organization of the American Public Transportation Association. The program is funded by the FTA and is managed by TRB.
- Safety IDEA focuses on innovative approaches to improving motor carrier, railroad, and highway safety. The program is supported by the Federal Motor Carrier Safety Administration and the FRA.

Management of the four IDEA programs is integrated to promote the development and testing of nontraditional and innovative concepts, methods, and technologies for surface transportation.

For information on the IDEA programs, contact the IDEA programs office by telephone (202-334-3310); by fax (202-334-3471); or on the Internet at <http://www.trb.org/idea>

IDEA Programs
Transportation Research Board
500 Fifth Street, NW
Washington, DC 20001

The project that is the subject of this contractor-authored report was a part of the Innovations Deserving Exploratory Analysis (IDEA) Programs, which are managed by the Transportation Research Board (TRB) with the approval of the Governing Board of the National Research Council. The members of the oversight committee that monitored the project and reviewed the report were chosen for their special competencies and with regard for appropriate balance. The views expressed in this report are those of the contractor who conducted the investigation documented in this report and do not necessarily reflect those of the Transportation Research Board, the National Research Council, or the sponsors of the IDEA Programs. This document has not been edited by TRB.

The Transportation Research Board of the National Academies, the National Research Council, and the organizations that sponsor the IDEA Programs do not endorse products or manufacturers. Trade or manufacturers' names appear herein solely because they are considered essential to the object of the investigation.

Smart Sensor System for Monitoring Railcar Braking Systems

IDEA Program Final Report
For the Period *September 2005* through *May 2008*
HSR-51

Prepared for
The IDEA Program
Transportation Research Board
National Research Council

Darrell Socie
Christopher Barkan

Railroad Engineering Program

University of Illinois at Urbana-Champaign

June 2008

IDEA PROGRAM

Funding and technical support for this project was provided by the High-Speed Rail IDEA Program. The mission of the High-Speed Rail-IDEA Program is to foster innovation in rail transportation by providing start-up R&D funding and support for promising but unproven concepts.

The High-Speed Rail-IDEA Program is funded by the Federal Railroad administration and managed by the Transportation Research Board (TRB) of the National Research Council. The High-Speed Rail-IDEA Program is one of four IDEA programs managed by TRB. The other three are Highway IDEA, Transit IDEA, and Safety IDEA.

- NCHRP Highway IDEA, which focuses on advances in the design, construction, safety, and maintenance of highway systems, is part of the National Cooperative Highway Research Program.
- Transit IDEA, which seeks advances in efficiency, safety, and maintenance of transit systems, is part of the Transit Cooperative Research Program and funded by the Federal Transit Administration.
- Safety IDEA focuses on innovative approaches to improving railroad, intercity bus, and truck safety. The program is supported by the Federal Motor Carrier Safety Administration and the FRA.

IDEA programs support new concepts often too risky for traditional R&D funding. The focus is on concepts with potential for technology breakthroughs rather than incremental improvements to conventional technology.

Proposals to the IDEA program are welcome from any business, organization, institution, or individual. All proposals are evaluated by committees established by TRB. Technical guidance for projects is provided by expert panels with members that possess relevant technical expertise and that represent the user community for the specific IDEA product under development.

Additional information can be obtained on the IDEA website at: www.trb.org/idea

The publication of this report does not necessarily indicate approval or endorsement of the findings, technical opinions, conclusions, or recommendations, either inferred or specifically expressed therein, by the National Academy of Sciences or the sponsors of the IDEA programs from the United States Government.

ACKNOWLEDGMENTS

We wish to acknowledge all of the people at the CSX Avon yard and NS Decatur yard for their help with all of our field testing. In particular we would like to thank Gary Nelson of Norfolk Southern and Dave Davis of the Transportation Technology Center, Inc. for their help in setting up and scheduling the field testing portion of the project.

ABSTRACT

As railroad loads get heavier, speeds get faster, and the demand for service quality and safety increase, the ability to monitor and process information about the health of a myriad of components of the rail transportation system increases correspondingly. In the particular application demonstrated here, smart sensors are used to directly monitor braking forces applied on a railcar. Although the technology to perform this has existed for many years, the ability to apply it has been severely constrained by the cost of the hardware, the extensive preparation required to apply instrumentation, and the infrastructure required to monitor and process the information. Our objective was to build a system that will be low-cost and maintenance free. This is only possible by using consumer rather than research and engineering technologies. To meet this challenge we developed a product comprised of three subsystems: a sensor for measuring forces, a wireless network for communicating the information so that some action may be taken, and an energy harvesting device, in lieu of conventional batteries, to make the system maintenance-free. Prototype sensor systems were fabricated and extensively tested. These tests all demonstrated that the sensor system was able to detect the application of forces to a brake beam. Tests in revenue service demonstrated the reliability and durability of the system in the electrical, magnetic and mechanical loading environment typically encountered by a railcar. A coupled electrical, magnetic and mechanical model of a power harvester was constructed and employed to design a power harvester for this application. Tests were conducted on a prototype harvester. Field tests to measure the vibration of a brake beam were conducted to determine whether ambient vibrations on a moving car could reliably drive a power harvester. These tests showed considerable variability in the vibration environment that will have to be considered in the final design.

Key Words: Structural Health Monitoring, Power Harvesting, Wireless Sensors, railcar health monitoring

TABLE OF CONTENTS

| | |
|---------------------------|----|
| Executive Summary | 1 |
| Project Description | 2 |
| Background and Objectives | 2 |
| IDEA Product | 3 |
| Concept and Innovation | 4 |
| Investigation | 6 |
| Sensor | 6 |
| Network | 8 |
| Power Harvesting | 9 |
| Cost Estimates | 16 |
| Field Testing | 17 |
| Project Panel | 23 |
| Findings and Conclusions | 24 |
| Plans for Implementation | 24 |
| Investigator Profile | 26 |

EXECUTIVE SUMMARY

In the Federal Railroad Administration's Five-Year Strategic Plan for Railroad Research, Development and Demonstrations (RD&D) the second chapter outlines a vision for the Intelligent Railroad Systems of the future (FRA 2002). The opening sentence in that chapter is: "A theme cutting across virtually all the RD&D program elements is the use of sensors, computers, and digital communications to collect, process, and disseminate information to improve the safety, security and operational effectiveness of railroads." The work performed on this contract is a critical element of that vision. It combines the three elements mentioned above, sensor technology, computers, and digital communications, in one, low-cost, integrated unit that is just over one square inch in size.

As railroad loads get heavier, speeds get faster, and the demand for service quality and safety increase, the ability to monitor and process information about the health of a myriad of components of the rail transportation system increases correspondingly. Although the technology to perform this has existed for many years, the ability to apply it has been severely constrained by the cost of the hardware, the extensive preparation required to apply instrumentation, and the infrastructure required to monitor and process the information. The technology proposed here will substantially reduce the requirements and cost of sensors and enhance the integration of the information they provide. It has the potential to fundamentally transform the paradigm regarding use of sensor technologies in the rail environment from limited applications in specific research contexts, to widespread, routine use in normal operations.

Part of FRA's vision, which is shared by the railroad industry, involves development of on-board monitoring and control systems for railcars (FRA 2004). The technology proposed here does not duplicate, but in fact, strongly compliments that vision because it will provide a low-cost means of obtaining and wirelessly communicating vital information on the car, the train and even on wayside systems. Beyond its data gathering and processing capability, smart sensor technology is inexpensive and has very low power requirements. Consequently it should be feasible to economically deploy it much more widely. Because of its low power requirements, it will be able to harvest sufficient energy from the movement and vibration of the surface upon which it is mounted to substantially reduce or even eliminate the need for any other power source, thereby further improving both reliability and economical operation. In the particular application demonstrated here, the smart sensors are used to directly monitor braking forces applied on a railcar.

Our concept was to build a sensor system that will be low-cost and maintenance free. This is only possible by using consumer rather than research and engineering technologies. An example is a simple bathroom scale that measures force. An electronic scale cost less than \$30. Conceptually a bathroom scale measures force just like those in a brake beam. Similar measurement technologies can be found in children's toys. Self-powered consumer devices are also available. A self-powered flashlight can be purchased for less than \$5. How can these consumer technologies be combined and used in the railcar environment? A low-cost, self-powered wireless sensor system is needed for this application. To meet this challenge we developed a product comprised of three subsystems: a sensor for measuring forces, a wireless network for communicating the information so that some action may be taken, and an energy harvesting device to make the system maintenance free. The environment under a rail car is obviously a lot harsher than that seen by, for example, a bathroom scale. We have estimated, however, that the cost to ruggedize such a system, by potting all electronic components, would not substantially increase the costs. Preliminary cost estimates to equip a 100-car train, including the locomotive-mounted equipment, would be in the \$25,000-30,000 range.

Prototype sensor systems were fabricated and extensively tested. These tests all demonstrated that the sensor system was able to detect the application of forces to a brake beam. Tests in revenue service demonstrated the reliability and durability of the system. A coupled electrical, magnetic and mechanical model of a power harvester was constructed and employed to design a power harvester for this application. Tests were conducted on a prototype harvester. Field tests to measure the vibration of a brake beam were conducted to determine whether ambient vibrations on a moving car could reliably drive a power harvester. These tests showed considerable variability in the vibration environment that will have to be considered in the final design. Application of this technology is dependent on knowing the vibration environment for each application.

We envision at least three potential applications of this smart-sensor technology. It can be used to make the initial terminal brake test more efficient and effective, it can monitor brake status in real time and thus detect stuck or malfunctioning brakes, and it can provide real-time, continuous monitoring of train braking force, thereby facilitating calculation of braking distances, which is essential information for communications-based train control systems.

PROJECT DESCRIPTION

In the Federal Railroad Administration's Five-Year Strategic Plan for Railroad Research, Development and Demonstrations (RD&D) the second chapter outlines a vision for the Intelligent Railroad Systems of the future (FRA 2002). The opening sentence in that chapter is: "A theme cutting across virtually all the RD&D program elements is the use of sensors, computers, and digital communications to collect, process, and disseminate information to improve the safety, security and operational effectiveness of railroads." The work described here is a critical element of that vision. It combines the three elements mentioned above, sensor technology, computers, and digital communications, in one, low cost, integrated unit that is just over two square inches in size.

BACKGROUND AND OBJECTIVES

The ability to monitor the status of railcar braking force has several important implications for rail safety, reliability and economics. For a variety of reasons, railcar brakes may not be fully released when a train is moving. Consequently, the brake shoes are in contact with the wheel tread, or the rotor in the case of passenger car disk brakes, causing high friction and excessive heat buildup in the braking surface. The resultant heating can damage the wheel and lead to thermal cracking that may cause wheel failure. If the brakes are applied with sufficient force, the wheel may not rotate at all causing a flat spot to develop on the wheel as it skids along the rail head. These "slid flats" are a source of several problems. The excessive heat can cause formation of a brittle layer of martensite which in turn can lead to premature wheel failure. Flat spots can induce potentially severe dynamic loads in the track structure, depending on the size of the flat. Consequently, there are substantial benefits to both vehicle and track safety and performance if sticking brakes can be detected before they are able to cause damage. Presently, there is no independent confirmation of when the brakes are applied or released, or that they have actually responded in the desired manner. The only option is visual inspection, such as occurs during the routine brake test before a train leaves the terminal. Although many problems are found, enough are missed or develop after the train is under way that stuck brakes are considered a major problem by the rail industry. We have adapted low-cost, wireless, self-networking, sensor technology to provide real-time, independent, axle-specific estimates of the force being applied to the brakes on each wheel of every railcar.

A schematic illustration of a braking system is shown in Figure 1. The brake cylinder applies force to a series of levers and rods which are connected to the brake beams. Two brake heads, each holding a brake shoe, are attached to each brake beam. As the shoes push against the wheels there is resultant strain in the brake beams. Using the new technology, brake beams on each car will be fitted with a strain-gauge-equipped sensor. The degree and orientation of the strain provides a direct indication of the braking force being applied to the wheel. If the brakes are off the strain should be near zero, if they are applied and the shoes actually pushing against the wheel, there will be some amount of strain greater than zero, dependent upon the amount of braking force being applied. Unlike a single measurement of the brake cylinder force or displacement, this system can provide information for each truck, each wheelset, or even each wheel, depending on how many sensors an individual user wishes to apply.

Another potential benefit of strain-gauge-equipped, self-networking sensors on the braking system is that by providing an independent measure of the braking force being applied throughout the train it will enable improved calculation of the safe-stopping distance of individual trains. An aspect of considerable importance in Positive Train Control is the reliability and accuracy of the braking algorithm that allows the train operator, and the PTC system to know the stopping distance of a train. A train equipped with the system described herein would provide considerably better information because the actual braking force for each brake beam would be known. Instead of relying on averages or statistical estimates of a train's stopping distance, each individual train's stopping performance could be calculated during an initial brake test. Furthermore, with the appropriate algorithms, the braking distance estimate could be automatically updated each time a brake application was made. The benefit of improved stopping distance information is the ability to take greater advantage of flexible block aspects of PTC because safe stopping distances could be more reliably calculated, thus enabling closer spacing of trains, and at the same time potentially enhancing safety.

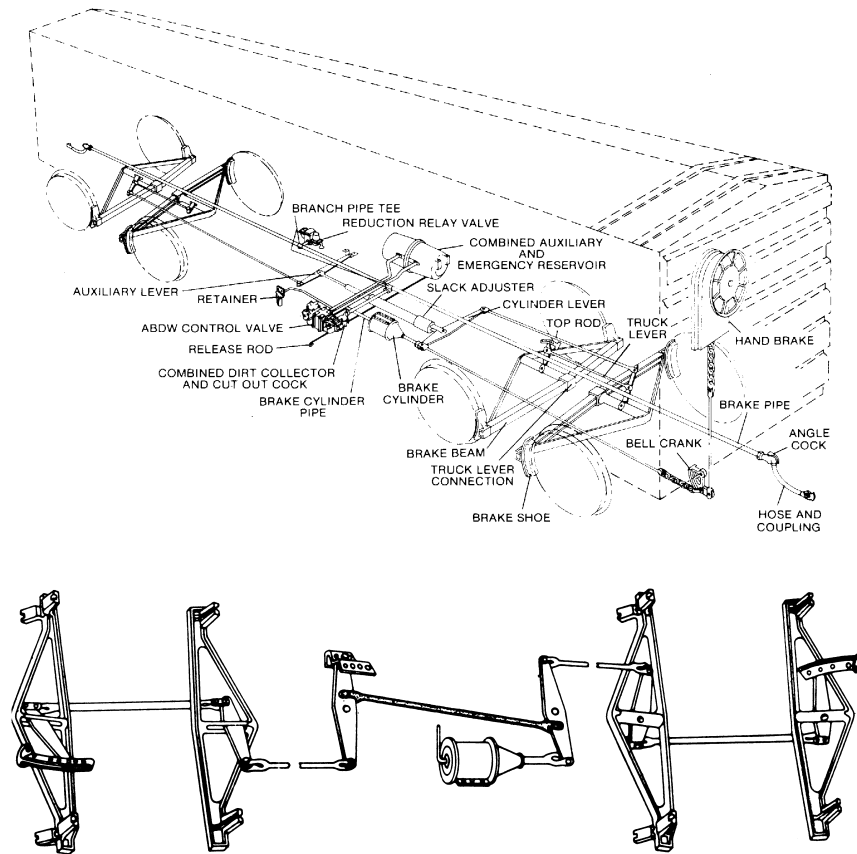

FIGURE 1 Schematic view of rail car braking system components (upper), and an isolated view showing the brake beams in relation to the cylinder and brake rods (lower).

An easily-manufactured, robust, and accurate strain sensing element and a low-power, low-cost wireless network has resulted in a technically feasible and economically affordable wireless system for brake beam monitoring that will operate for extended periods without battery replacement when connected to an energy harvesting device. The whole system has been designed to require a total of only a few milliwatts of power and to be able to be produced in large quantities for a reasonable cost. Mass produced, the system should cost less than \$60 per sensor. An individual railcar would nominally require 4 sensors, with one of the sensors also serving as a router. This equates to about \$25,000-\$30,000 for a 100-car train, including the locomotive-mounted equipment. To meet these cost objectives, the smart sensor system was built primarily from off-the-shelf consumer-grade electronics. These estimates include the costs to ruggedize the system to withstand the under-car environment by potting all electronic components.

IDEA PRODUCT

The IDEA product developed in this investigation is shown in Figure 2. It is a small, low-power device that is attached to the brake beam of a railcar. Both forces and accelerations can be measured and wirelessly transmitted to a central node on the railcar. Railcars are linked together in a self-forming network to provide real-time brake forces. The sensor system took less than ten minutes to install. The IDEA product developed in this investigation is a system comprising three major subsystems; sensor, wireless network and energy harvester.

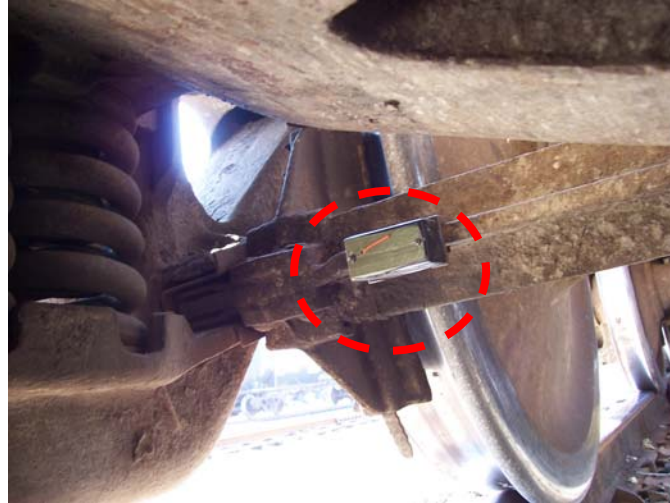

FIGURE 2 Sensor mounted on a brake beam

Although the product was developed for measuring brake forces, it has applications wherever forces need to be measured. Examples include stresses in rails, railcars, and infrastructure such as bridges. It could also be used to measure ride quality and be used to detect the onset of mechanical failures.

CONCEPT AND INNOVATION

It is possible to measure brake beam forces and compute brake effort using existing technology and systems. However these systems are expensive often costing more than \$10,000 for the equipment. Installation costs are also several thousand dollars. Power requirements are such that batteries need to be replaced every few months. One manufacturer, for example, makes an energy harvesting device that can replace the batteries. The cost of these harvesters is more than \$500 and at least 4 harvesters would be needed for each railcar. Traditional measurement equipment makes a brake beam monitor too expensive and a different way must be found. Our objective was to build a low-cost system that will be maintenance free. This is only possible by using consumer rather than research and engineering technologies. An example is a simple bathroom scale that measures force. An electronic scale cost less than \$30. Conceptually a bathroom scale measures force just like those in a brake beam. Similar measurement technologies can be found in children's toys. Self powered consumer devices are also available. A self powered flashlight can be purchased for less than \$5. How can these consumer technologies be combined and used in the railcar environment? This is the primary focus of our project. To meet this challenge we developed a product comprised of three subsystems: a sensor for measuring forces, a wireless network for communicating the information so that some action may be taken, and an energy harvesting device to make the system maintenance free. Each of these subsystems will now be described.

Figure 3 shows the inside of the smart sensor mounted to a simple beam. It is composed of a wireless transceiver, processor, analog electronics, and a sensing element. An internal battery powers the system during normal operation and is recharged from an external energy harvesting device when the railcar is in motion. The sensor is simply bolted on the structure to reduce installation costs. A portable stud welder was used to attach the sensor in Figure 3. This attachment method can be done by a semiskilled person and eliminates the need for a trained technician to apply strain gages directly to the brake beam. One of the major innovations in this system is the sensor plate which acts as a strain multiplier so that small strains can be measured. This element reduces the installation costs from a few hundred dollars to a few dollars.

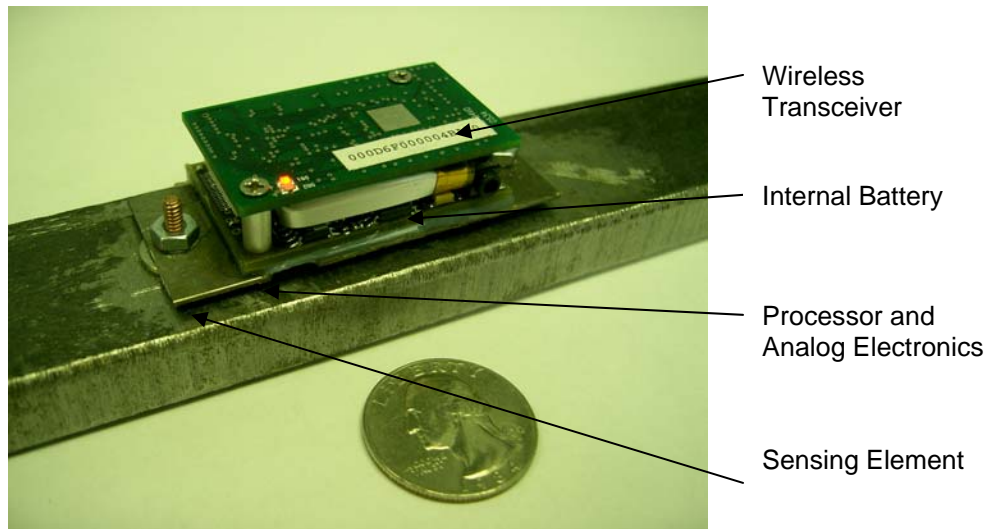

FIGURE 3 Wireless smart sensor

Sensors on an individual railcar are configured into a local network. Sensor nodes are configured in a star network and only communicate with other sensors and routers on the same railcar. This is configured during the initial installation. Each sensor has a unique 64-bit identification number (a billion possibilities). The network on an individual car is configured to only accept sensor numbers from a predefined list. Routers communicate with both sensors on an individual railcar and routers on adjacent railcars as illustrated in Figure 4. A mesh style network is used with the routers. Physically one of the sensors is also a router so that no additional hardware is needed.

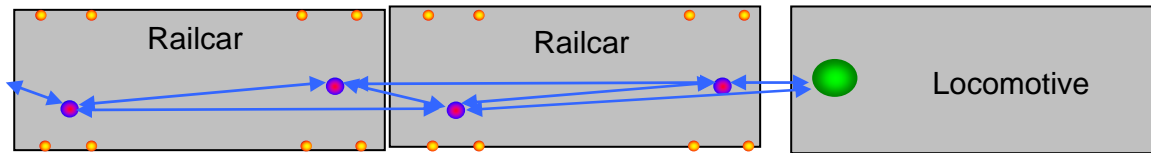

FIGURE 4. Networked railcars

We have selected the new Zigbee networking technology for this product. It is based on a self-organizing network standard (IEEE 802.15.4) which is supported by many vendors. This choice makes it possible to seamlessly add other Zigbee sensors to the system. A self-organizing, self-healing wireless embedded networking platform, EmberZnet was used for the system. These networking algorithms deliver connectivity with industrial-strength reliability, security, and unprecedented ease of use. The EmberZNet product enabled rapid development and deployment of the network without developing any low level software.

To be cost-effective an energy harvester is used to power the system in lieu of conventional batteries. Figure 5 shows the prototype energy harvester developed in this project. An AA battery is shown in the photo to provide a size comparison. Such energy harvesters convert mechanical vibration energy into electrical energy. They are tuned to operate at different frequencies to achieve maximum power output. A mechanical, magnetic and electronic circuit model was built to optimize the design of the energy harvester for railcar applications.



FIGURE 5 Prototype energy harvester

The primary technical innovation in this IDEA project was to design, build and test a cost-effective system for measuring forces and accelerations on a railcar. This was accomplished by using consumer product technology and configuring it in a unique way to develop the measurement system.

INVESTIGATION

Rather than report the development of the system in chronological order it is more logical to divide the discussion of this project into four subsections: sensor, network, power and field testing.

Sensor

Each sensor monitors one channel of localized displacement for determination of brake beam strains, two channels of acceleration and its own internal battery voltage to facilitate power management. These small sensors are self-contained and are easily attached to a variety of engineering materials such as steel and concrete. The overall sensor dimensions are 63mm x 25mm x 13mm (2.5" x 1" x 0.5"). Rather than measure strains directly on the brake beam, the smart sensor measures the deflection of a uniquely designed sensor plate described later. This eliminates the need to install strain gages in the field. Sensor installation is quick and easy; they are simply bolted on after first welding threaded studs at appropriate locations on the brake beam with a commercial stud welder. Special adapters can be used instead of welded studs for short term testing.

The current version of the smart strain sensor (shown in Figure 3) is composed of three major subsystems: a wireless transceiver, processor and analog electronics, and a sensing element. An internal battery powers the system and may be recharged from external power or energy harvesting devices. The wireless transceivers provide communication between smart sensors by using a robust mesh networking protocol called Zigbee. The processor and analog electronics module controls the sensor's data acquisition activities, In particular, it provides signal conditioning for strain and acceleration transducers, performs online data sampling and manipulation, and archives the collected data for eventual transfer off the sensor network. The sensing element is a machined steel plate with factory installed strain gages calibrated to measure relative displacement between the sensors mounting holes.

In order to accurately sense brake beam strains, a strain sensor plate was developed in this project. The plate can be attached to the brake beam with either C-clamps for a temporary installation, or with welded studs for a more permanent installation. The challenge in engineering a strain sensor plate is to make the plate sensitive enough to measure relatively

small strains, yet stiff enough to prevent damage to the plate itself. The machined plate is compliant in the longitudinal direction while remaining quite stiff in all other directions. Furthermore, the plate must be engineered such that the forces transmitted through the plate do not exert undue stress on the attachment mechanism—studs or C-clamps and the maximum stress that the plate experiences must be below the fatigue limit of the plate material. Finally, the design must ensure that the sensor plate not buckle when loaded in compression.

To efficiently satisfy the design parameters of the sensor plate, a finite element model of the plate was generated, shown in Figure 6. Five thousand ohm strain gages are located at the two thinned sections on the left side of the element and strain relief slots are cut into the element on the right side. Without the strain relief slots, the plate actually amplifies the mechanical strain. The mechanical strain amplification can be as high as 20-to-1, making this system more sensitive than a MEMS strain gage. By adjusting the size and location of the strain relief slots, the sensor can be tuned to a particular strain range. For the brake beam sensor plate, large strains were anticipated; therefore, the strain relief slots were engineered to reduce the mechanical advantage from a 20X amplification to a 5X reduction. This reduction prevents damage to the plate during loading and allows operation over a wide range of strains.

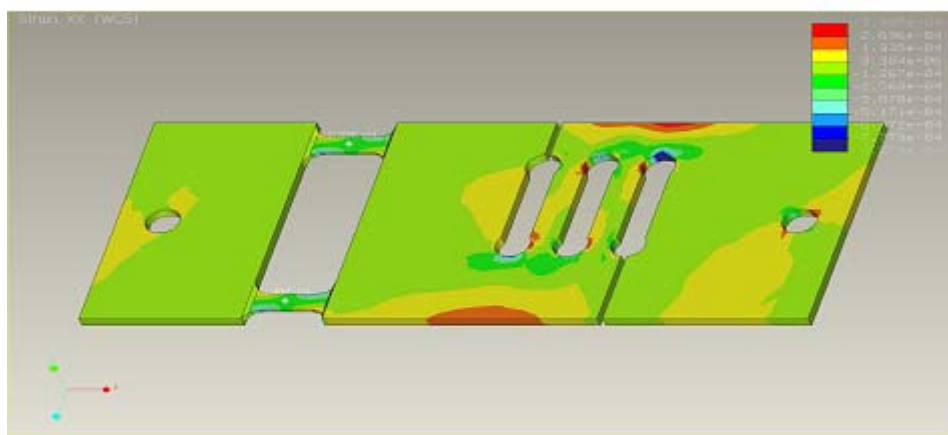

FIGURE 6 Strain sensing element finite element model

The analog section of the smart sensor system was developed on another project and no further work was needed for this work. The TI MSP430 processor is a new generation product that has been optimized for both analog and digital circuitry and has been specifically developed for low powered sensor applications. It is a single chip that contains all of the necessary analog and digital circuitry needed for the brake monitoring system except the transmitter. Flash memory is included so that it is remotely programmable. Figure 6 shows a schematic diagram of the smart sensor system. Interface circuitry is needed to condition the strain gage bridge and amplify the voltage for measurement by the MSP 430.

An emerging low-cost, low-power wireless technology commonly called Zigbee™ is now commercially available. It is based on a self-organizing network standard (IEEE 802.15.4) which has a range of up to 100 meters and is supported by many vendors. A self-organizing, self-healing wireless embedded networking platform, EmberZNet is used for this system. *Control Engineering* magazine’s editors named Ember Corporation’s [EM2420 embedded wireless networking solution](#) one of the most significant technical innovations of 2003. These networking algorithms deliver connectivity with industrial-strength reliability, security, and unprecedented ease of use. Designed from the ground up for developers of sensing and control products, the EmberZNet product suite enables rapid development and deployment of embedded wireless networks. Security of wireless communications is a serious issue and probably of greater concern than ease of configuration and use. There are really two security considerations concerning the integrity of the network, unintentional interference and intentional sabotage. Unintentional interference can only occur if two networks occupy the same frequency band (1 in 16 chance). If there isn't enough bandwidth to support the needs of both networks, the performance of both will suffer. If this happens, the entire network can change to another less-crowded frequency band. In addition, there is a very small chance that the networks could interfere at the software level, thus incorrectly sharing packets. For this to happen the two networks must have the same PAN ID (1 in 65,536 chance) and the same Zigbee Profile (1 in

65,536 chance). To prevent intentional sabotage, a layer of encryption can be added. However, this does lower the effective throughput of the network. Ember solves this problem with a suite of encryption routines built into their EmberZNet library.

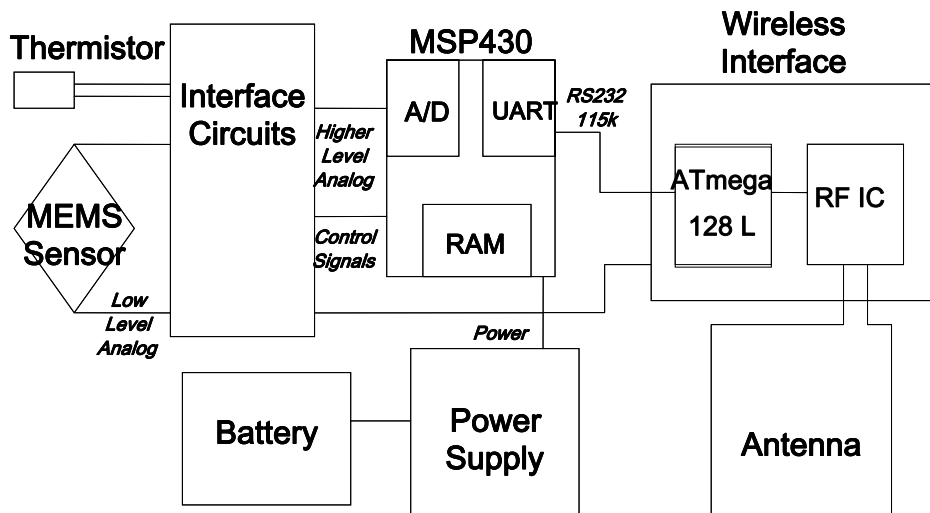

FIGURE 7 Smart sensor system schematic

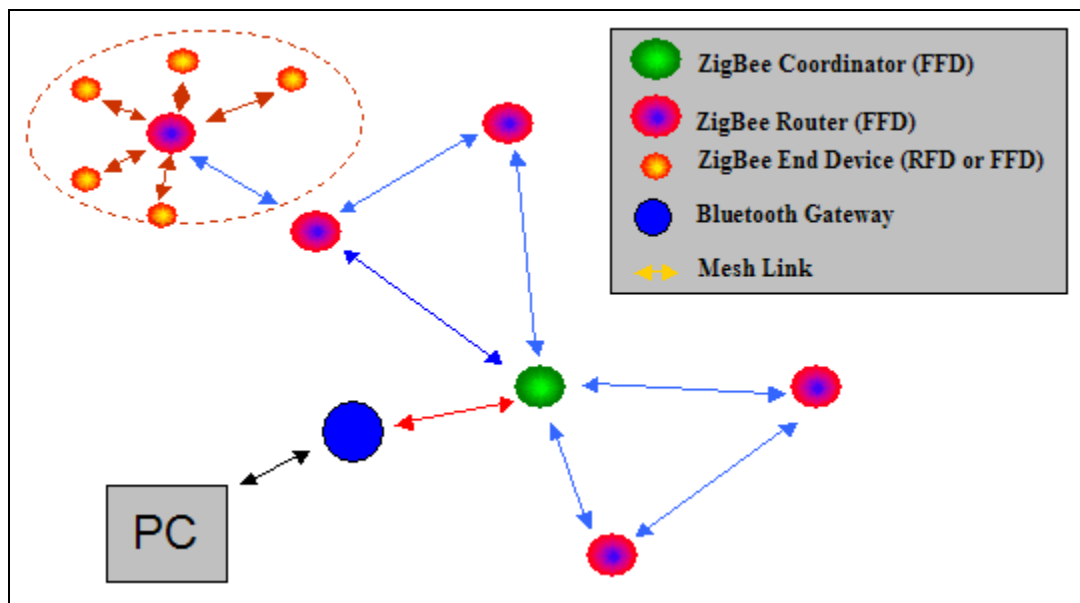

FIGURE 8 Zigbee mesh network topology

Network

Figure 8 shows the basic elements of the Zigbee network we have employed for the smart sensor. The Zigbee Coordinator is a special node that is responsible for dynamically forming a network, keeping track of active sensors and

often transferring data through a gateway to a PC, PDA or other archival facility. Zigbee Routers are responsible for relaying data packets to neighboring nodes according to the mesh networking logic of the Zigbee protocol. They may also be sensors gathering data. Zigbee End Devices are extremely low-powered nodes that collect data but communicate only when absolutely necessary to minimize power consumption. The Zigbee network topology provides the flexibility necessary for many sensor applications.

The gateway module developed for this project is a portable, battery-powered device that provides translation between two different communication media, in this case, between Zigbee and Bluetooth. This device makes it easy for any PC or PDA with internal Bluetooth to communicate with a Zigbee-based smart sensor network and is ideally suited for initial testing of the system. Figure 9 shows the prototype gateway module used in this project.

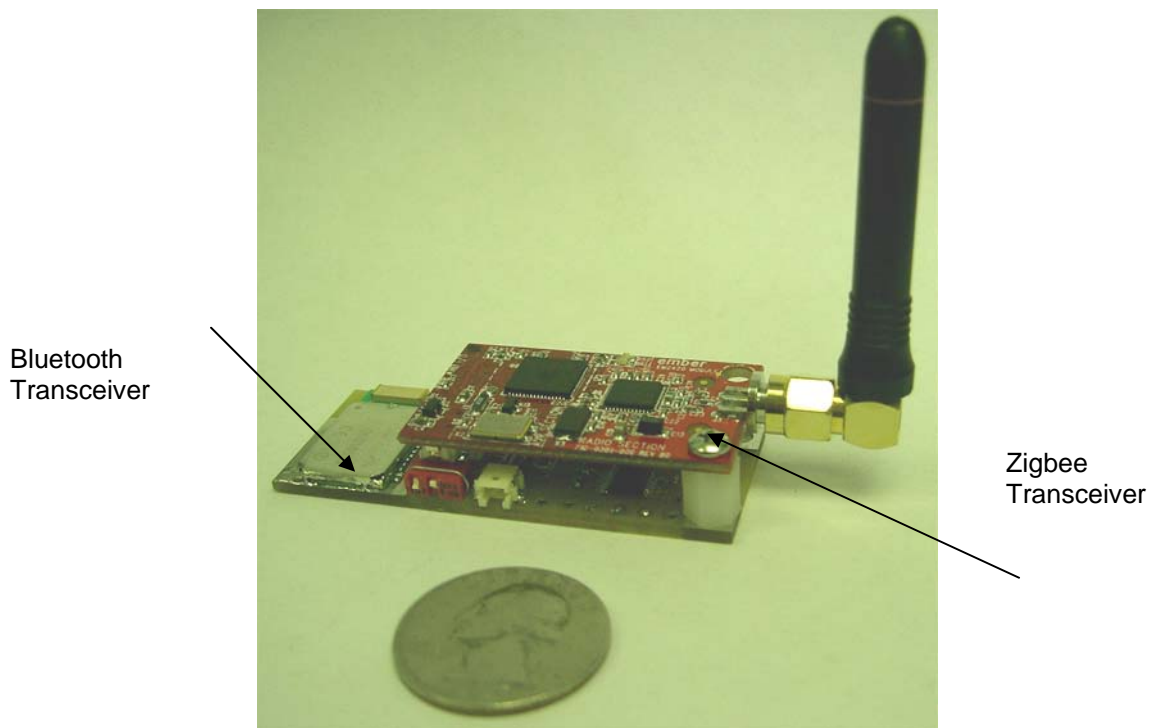

FIGURE 9 Gateway node

Power Harvesting

Because the smart sensors must remain operational for years, battery-powered devices are infeasible. Even with the extremely low power consumption of the smart sensors, powering a smart sensor for 10 years on a battery would require a battery of considerable size and reliability. Therefore, a significant program of research, modeling, and experimentation was undertaken to solve the power problem. The issue of power is the lone remaining fundamental technical hurdle to long-term deployment of a smart sensor network in the rail industry.

Table 1 summarizes the power consumption of the smart sensors. The single largest determining factor in the power consumption is the amount of time the radio is on. We estimated that the smart sensors mounted on brake beams will not have to have their radios on for more than 1% of the time. Furthermore, because of the relatively slow dynamics of brake beam actuation, sampling rates can be held to a few tens of samples per second (at most) and the sensor and processor can spend much of their time in very low power sleep modes. Examining Table 1, it is well within the capability of the smart sensor to run indefinitely on just a few milliwatts of power.

| | Power(mW) | Standby Power (mW) | Duty Cycle (%) | Total Power (mW) |
|----------------------|------------|--------------------|----------------|------------------|
| Strain Sensor | 0.2 - 2.0 | 0 | 1 - 100 | 0.002 - 2.0 |
| MSP430 | 1.5 - 12.0 | 0.015 - 0.12 | 1 - 10 | 0.015 - 1.2 |
| 2.4 GHz Radio | 60.0 | 0.0015 | 1 - 5 | 0.6 - 3.0 |

Table 1 Smart sensor power requirements.

Preliminary research, modeling, and prototyping have been performed on energy harvesting devices. The most promising technology for application on a brake beam is an electromagnetic device that harvests energy from the ambient vibration of the moving railcar. The device consists of small (6 to 12 mm) permanent magnets vibrating within a coil to produce a current. A model showing the electromagnetic field lines of the magnetic stack can be seen in Figure 10.

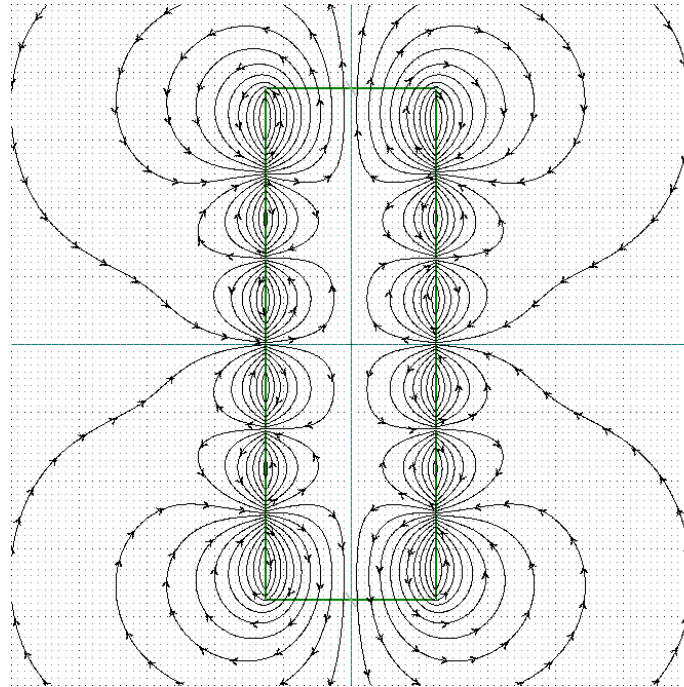

FIGURE 10 Model of magnetic stack in energy harvester

One of the crucial considerations for a vibration-based energy harvesting device is the frequency range that it will operate over. The device must be tuned to frequencies that are present on the brake beam. The smart sensor has a MEMS accelerometer integrated into it which allows for characterization of the vibration environment on a brake beam. Once the vibration environment is characterized, the mechanical frequency response of the harvester can be adjusted for optimal power generation. Furthermore, the electrical system must be designed so that power is not lost during the conversion of mechanical to electrical energy. All of these tasks are currently ongoing as part of a follow-on effort subsequent to this HSR-IDEA project, and a complete system-wide model of the energy harvester, from mechanical inputs through circuit models of the power output is being developed.

Once the power is harvested, it is stored in a small battery onboard the smart sensor. A substantial amount of testing was performed on various battery chemistries. The smart sensor has rather stringent battery requirements. The battery must be very small and flat with a high energy density; it must deliver relatively large amounts of current for the few seconds that the radio is on; it must be rechargeable over a wide range of current levels—from trickle charging to a full charge; and it must operate over extreme temperature ranges. After a lengthy search and evaluation process, it was decided to use lithium-polymer flat pack batteries. Within a space of 20 mm x 20 mm x 5 mm thick (0.8” x 0.8” x 0.2”), the new lithium-polymer series batteries can store enough energy to power a continuously “on” smart sensor for over 6 hours—see Figure 11. Lower temperatures increase the battery’s internal resistance which lowers the output voltage and increases the discharge rate. At -20C these batteries will only power the system for half as long as at +20C. For the 1%

duty cycles anticipated for brake beam monitoring, this corresponds to 300 hours of sensor life at -20C on a fully charged battery and represents a significant power reserve in cases where the energy harvester remains dormant.

Both electromagnetic and piezoelectric technologies were evaluated for this project from both a cost and performance viewpoint. Both harvest vibrational energy and have similar performance and will provide the needed power of 1 milliwatt in a small package. But the cost of an electromagnetic power device is an order of magnitude less. The first step in designing an efficient energy harvester was an analytical model to select the optimum magnet/coil configuration. This was followed by the detailed mechanical design. Finally, a prototype harvester was built and tested.

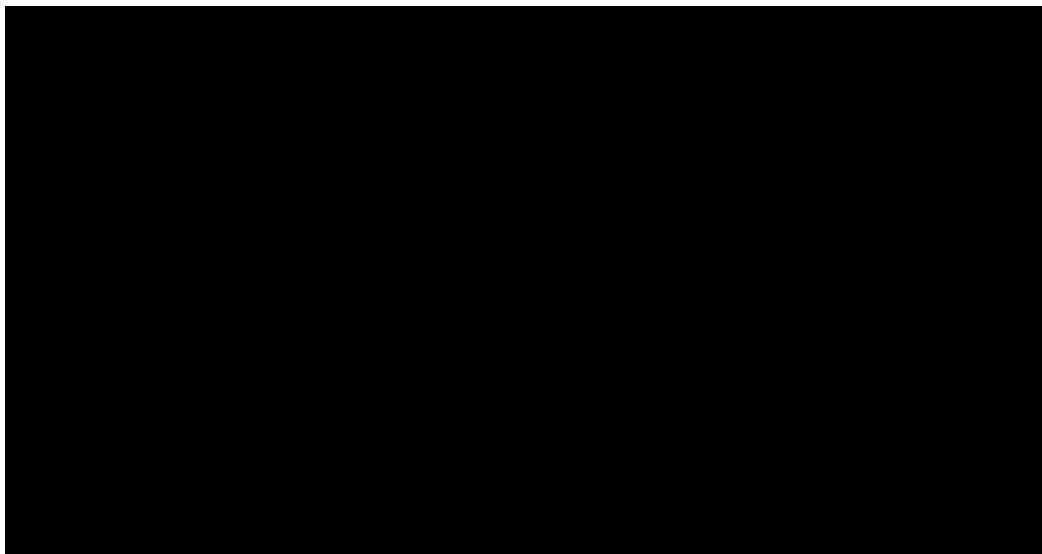

FIGURE 11 Measured discharge profile of lithium polymer battery

The state of the art in commercial electromagnetic finite element analysis software is Ansoft Corporation’s line of Maxwell FEA 2D and 3D software. The software can model both linear and nonlinear systems. A typical model is shown in Figure 12. Generally, each region was meshed with 100 elements. Figure 10 shows the necessary regions for the FEA model.

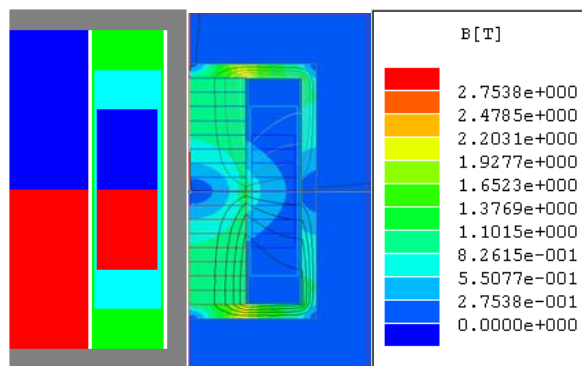

FIGURE 12 Two magnets, 2 half coils with steel. Power output is 231 mW

In a previous study, the vibrations on the brake beam have been reported to be 20 g’s on average with peak accelerations of around 40 g’s. The dominant frequency occurs at approximately 100 Hz. For this study, all energy harvester models are excited with 20 g’s at 100 Hz. The acceleration of the modeling frame is given by

$$a = -20 * g * \sin(2 * \pi * 100 * t) \quad (1)$$

where g is acceleration due to gravity (9800 mm/s^2). By integration, the velocity of the frame is given by

$$v = \frac{20 * g * \cos(2 * \pi * 100 * t)}{2 * \pi * 100} \quad (2)$$

And, by further integration, the position of the reference frame is given by

$$p = \frac{20 * g * \cos(2 * \pi * 100 * t)}{4 * \pi^2 * 100^2} \quad (3)$$

Based on this choice of vibration environment, the peak-to-peak displacement of the vibration is 1 mm. As this study will show, this very low level of displacement is a critical factor in designing the harvester. Because the displacement is so low, it is critical that the magnetic flux be as concentrated as possible with a small area.

The external circuit is a simple full-wave diode rectifier shown in Figure 13. The load resistance of the circuit is set at 200 ohms. This load is based on the power consumption of a typical smart sensor at a moderate load, which is 20 mA at 4V. The external capacitor is chosen based on the RC time constant corresponding to 4 vibration cycles. This keeps the ripple voltage down to an acceptable 0.2V to 0.3V level in the final design. The final capacitance value used for all analyses is 200 uF. The voltage drop for the diodes is 0.3V.

The results of the FEA analysis show that the energy harvester should theoretically produce 231 mW of power when continually excited at 100 Hz and 20 G's.

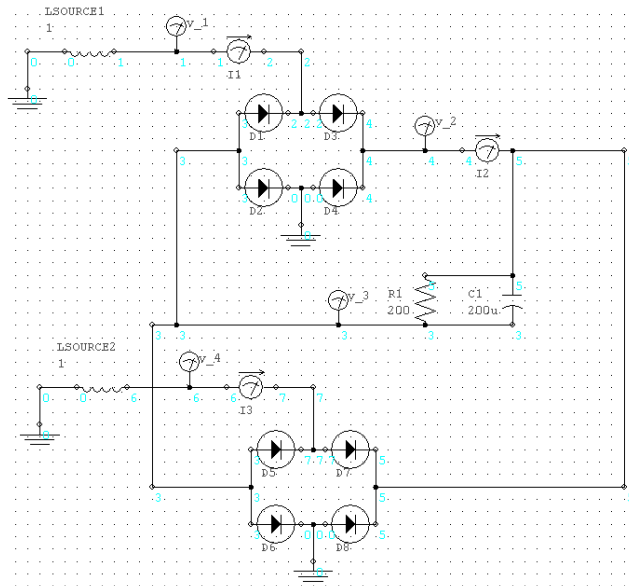

FIGURE 13 Two full wave rectifiers used for double coil designs

One of the main design goals of this energy harvester was that the operational portion of the device must be of a diameter and height of one inch. Because the magnetic field must be contained to provide the maximum power generation capability, the body of the energy harvester was made from steel so that the maximum amount of the magnetic flux was able to penetrate the power generating coils.

The magnets chosen were low-cost nickel plated, neodymium-iron-boron magnets. Specifically, the magnet was a disk of diameter 0.375 in. and height 0.25 in. These rare earth magnets were chosen as they provided the strongest magnetic

field per volume at the lowest cost. In the design, four magnets were stacked with opposing poles in the center. With the magnets in this configuration, the density of the magnetic field lines is very dense in the center of the stack. This is very advantageous as that is the zone where a coil of wires will be placed. The magnetic configuration is shown in Figure 14.

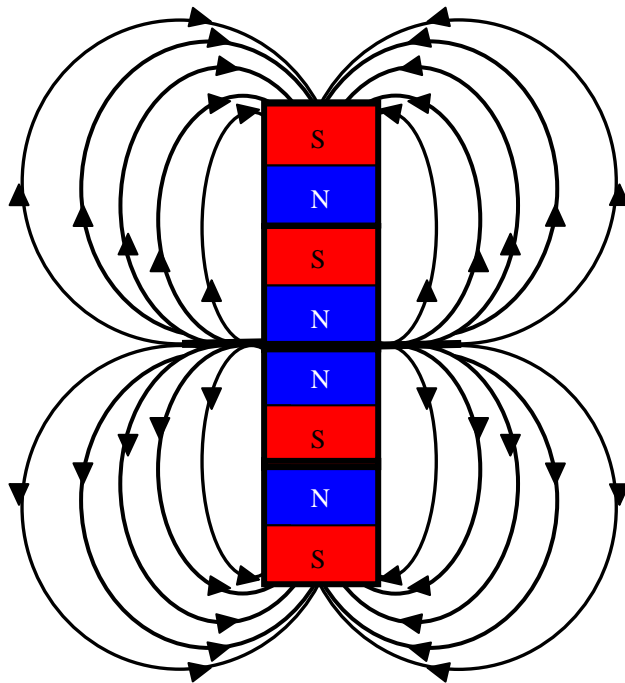

FIGURE 14 Magnetic configuration in energy harvester.
Note the dense field lines in the center of stack.

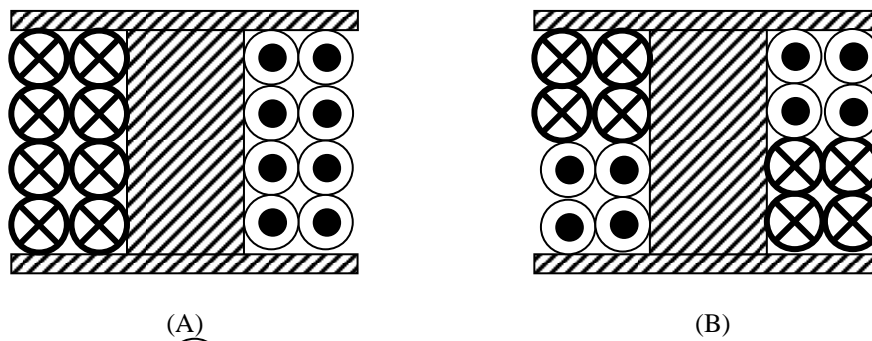

FIGURE 15 Schematic showing wrapping patterns. (A) shows an inefficient design with a single direction of wrapping, and (B) shows a preferential design with 2 separately wrapped coils. Note, the actual direction of wrapping is arbitrarily shown, and has no significance as long as the directions are opposed.

To fully exploit the dense magnetic field that is created in the center of the magnetic stack, special care must be taken when designing the coil of wires. The diameter of wire was chosen to be of minimal size to allow for the maximum number of coils without creating too large of a resistance. If a coil wound in a single direction is used, significant competing inductances will cancel each other out as the coil moves. This is due to the magnetic flux being in separate directions in relation to the top and bottom of the coil, thus inducing currents that cancel each other out. A way to remedy this situation is to create two separate coils wound in opposite directions. This would eliminate much of the

opposing inductance, and would allow the top coil and bottom coil to effectively add. A schematic showing the direction of the coil wrapping is shown in Figure 15.

Since the coil of wires required a spring to allow translational motion through the magnetic field, a leaf spring was chosen for this application. The leaf spring design was advantageous over a traditional coil design because a coil spring would occupy more space. Since a pair of leaf springs was placed on the top and bottom of the coil, the bottom springs were rotated 90° in relation to the top springs. The spring configuration is shown in Figure 16. This removed the possibility of any rotational degrees of freedom and constrained the system to only translational motion. For a material to construct the springs, blue tempered spring steel shim stock was chosen, and the shape of the spring was cut using an EDM (Electrical Discharge Machine). Three different thicknesses, 0.005", 0.010", and 0.015", were machined for testing.

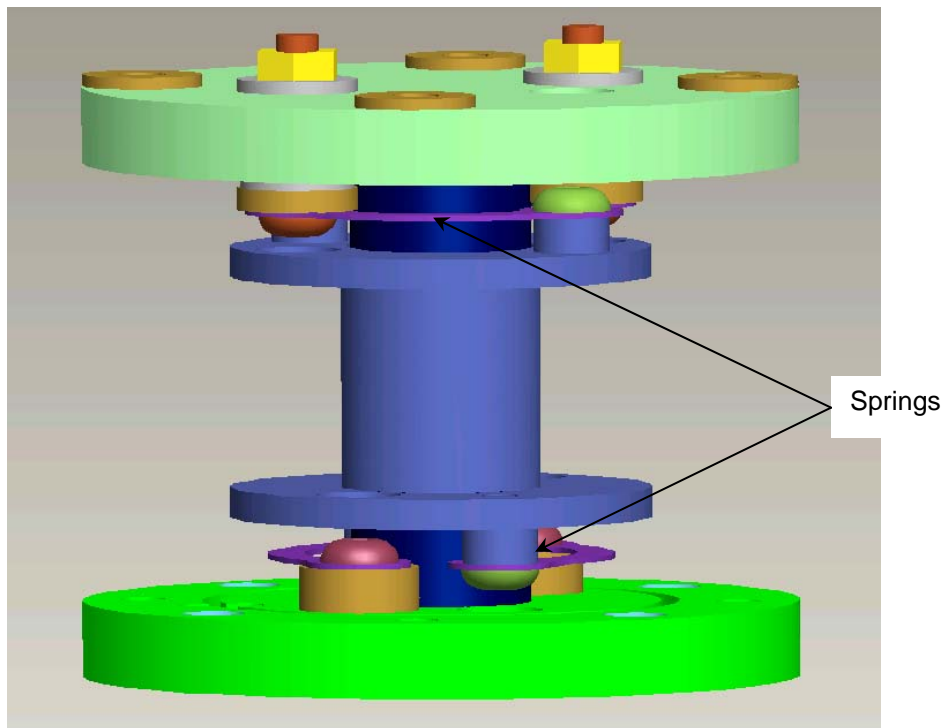

FIGURE 16 Leaf spring setup of energy harvester.

Note the 90° rotation of the top and bottom springs.

Since the main purpose of this energy harvester is to extract electrical energy, it is necessary to channel the current from the coil into a rectifying circuit that will convert the alternating current produced during coil motion to a usable direct current. The wire used to wrap the coil was intentionally chosen to be very small. However, the thin wire (30 gage) would easily fatigue as the coil moves up and down if it were connected to an outside source. To avoid wire fatigue, the wire from the coil was connected to the metal leaf springs on the top of the coil. However, since the entire case of the energy harvester was metal, the screws attaching the springs to the top of the case had to be electrically isolated from the rest of the system to avoid a short circuit. This was accomplished by using a nylon shoulder washer in the screw hole and using a nylon flat washer on top of the lid to prevent a securing nut from making electrical contact with the case. A drawing showing this electrically isolating design is shown in Figure 17. These screws will provide a path for the energy created to conduct to a separate source. Note, the top lid was removed for this picture.

The energy harvester was tested using an electromagnetic vibration shaker. An accelerometer was mounted on the energy harvester so the exact g-force level experienced by the energy harvester was known. Figure 16 shows the power output of the energy harvester with a 1 Kohm load normalized by the square of the g-force. The energy harvester was designed to have a resonant frequency of 100 Hz. As seen from Figure 18, the harvester had a resonant frequency of about 130 Hz. We consider this good agreement for the first prototype build. The resonant frequency of the harvester

can be tuned by changing the thickness of the leaf springs. The frequency will scale as the thickness to the 1.5 power. This would be a 15% reduction in thickness.

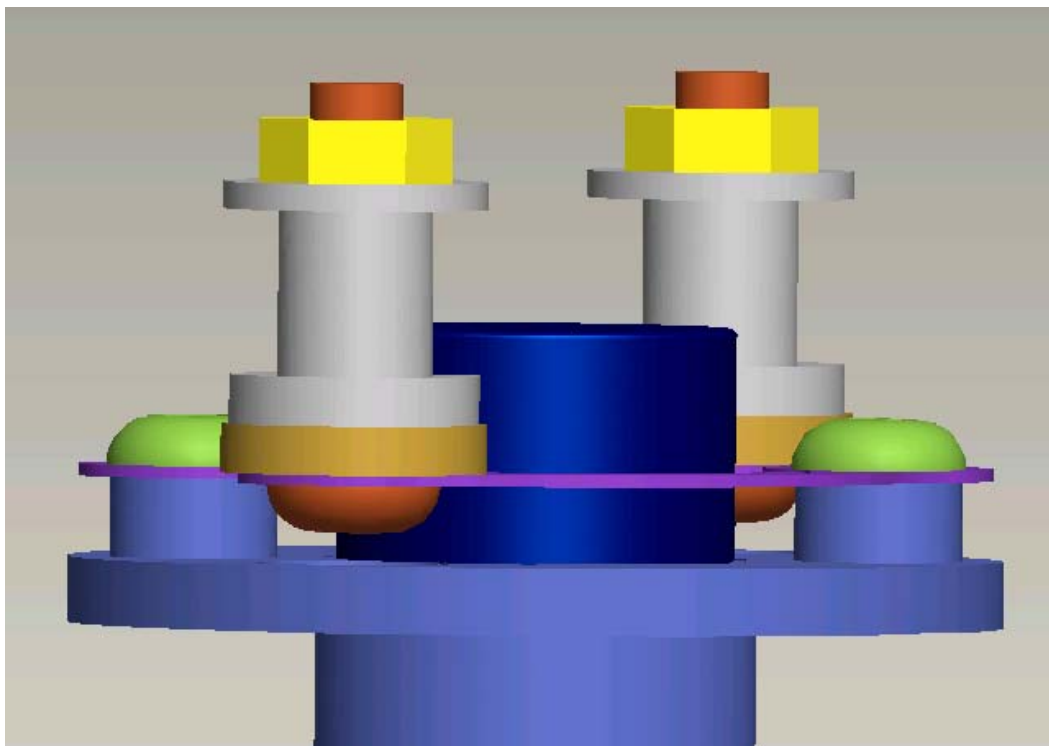

FIGURE 17 Electrically isolated screws

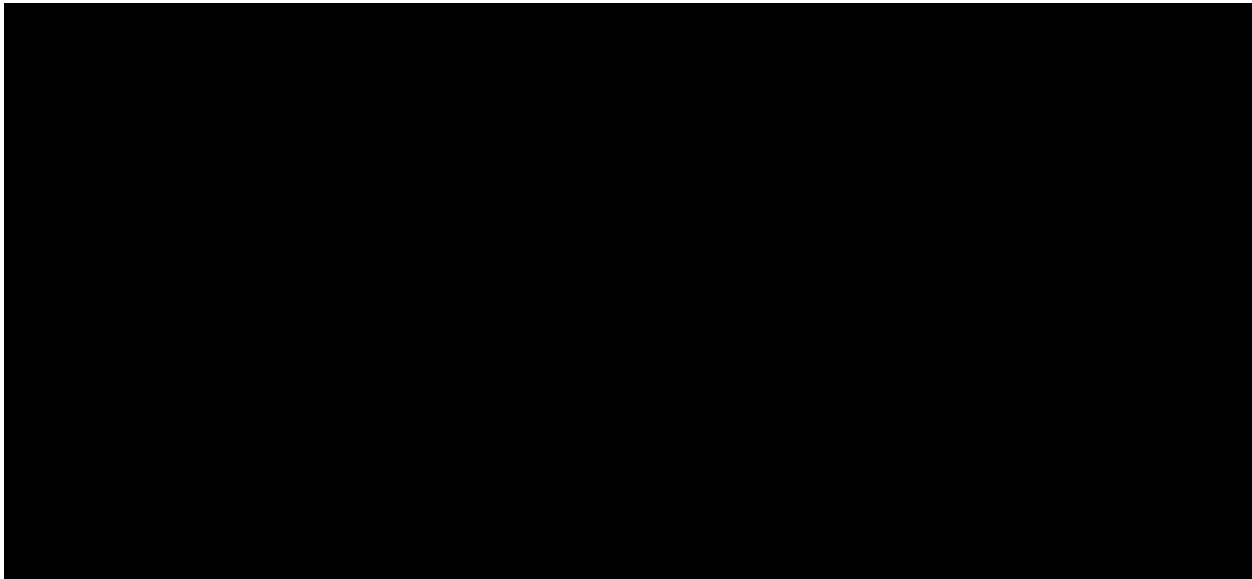

FIGURE 18 Power output of energy harvester with 1 Kohm load

The power generated by an electromagnetic energy harvester increases as the square of the g-level, to a first approximation. The FEA modeling of the previous section used a g-level of 20 G's at 100 Hz. Therefore, examining Figure 19, at the resonant frequency of 130 Hz and a load of 5 Kohms, the power at 20 G's can be extrapolated ((20 G's)² * 0.35) to 140 mW. From Figure 18, the power with at 1K load can be similarly extrapolated to 480 mW. Note that the FEA modeling predicted a power output of 231 mW. Our ability to estimate the power output of the harvester is much better than our ability to estimate the vibration environment of a railcar.

Cost Estimates

Cost estimates for producing and installing the smart sensor system were developed. To set a realistic cost goal we first evaluated similar consumer products to determine if it was possible to build a low-cost sensor system for railroad applications. The closest consumer product to our sensor is a simple digital bathroom scale. The Oregon Scientific BWR 102 wireless body weight monitor with body mass indicator retails for only \$54. This system contains four strain-gage-based load cells and a wireless transmitter. Our system contains only one strain gaged device. Energy harvesting devices are also commercially available. Perhaps the best examples are battery-less flashlights. These flashlights retail for less than \$10. An energy harvesting switch is marketed by EnOcean for \$50. All of these energy harvesting devices are based on simple electromechanical technology. These devices are similar enough to the brake monitoring system that we conclude that it should be possible to build systems in production quantities for about \$60/sensor, including the costs to ruggedize the components to withstand the under-car environment.

A cost analysis of the system is presented in Table 2. Our prototype costs are based on manufacturing 25 systems. Almost all of the cost is associated with labor. Mechanical parts are produced by numerical controlled machine tools. All electronic assembly is done by hand in the prototypes. For production quantities of 100,000 we expect that the electronics parts costs could be reduced by 50%. A new family of load cells from Measurement Specialties, Microfused™ load cells, are manufactured at a fraction of traditional cost, allowing pricing as low as \$5 each for high volume orders. These new sensors are made by fusing silicon strain gages at high temperature with inorganic glass to the load-measuring member. The glass bonding process eliminates the instabilities associated with conventional epoxy bonded strain gages, creating a more durable and stable sensor. Our sensors have been designed so that this technology could be employed for production quantities.

Our final cost estimate is \$59/sensor in large production quantities. This compares favorably with the retail cost of the benchmark bathroom scale and battery-less flashlight. We are able to install the sensor in about 10 minutes. Estimated cost for this labor is based on information from AAR that a reasonable cost for shop crafts, including overhead, is about \$50/hour. This installation labor cost will not be reduced with production quantities.

| | Prototype | Production |
|-------------------------|---------------|--------------|
| Sensor | | |
| Electronic parts | 53.08 | 26.50 |
| Sensor element | 65.00 | 5.00 |
| Assembly labor | 60.00 | 2.00 |
| Packaging | 20.00 | 2.00 |
| Energy Harvester | | |
| Electronics parts | 1.23 | 1.00 |
| Mechanical parts | 42.00 | 5.00 |
| Assembly labor | 25.00 | 5.00 |
| Installation | | |
| Labor | 12.50 | 12.50 |
| Total | 278.81 | 59.00 |

Table 2 Cost estimates.

Field Testing

During the first phase of this project, various field tests were performed to evaluate the smart sensors on brake beams. The purposes of these tests were to verify that the sensors could, indeed, sense the difference between a brake beam in the on and off positions and to verify that full radio communications can be established underneath railcars. The first set of tests was conducted at the Monticello Railway Museum in Monticello, Illinois. The sensors were mounted on a brake beam and the hand brake was released. The data from the smart sensor recorded a 60 microstrain difference between the on and off positions of the brake beam. Furthermore, it was established that 4 sensors mounted underneath the four corners of a railcar could communicate with each other and with a 5th sensor mounted at the far end of a second car attached to the first.

A second set of tests was performed at the Norfolk Southern rail yard in Decatur, Illinois. The sensors were mounted as close to the middle of the beam as space would allow in order to capture the large bending moment in the beam. For these tests, the brake beam was set with the hand brake and then quickly released. There were three rail cars with two different types of brake beams, a #24 and a Wabco beam. Both brake beams are geometrically similar and differ in the type and mounting of the brake shoes. This difference does not affect the operation of the sensor system as a brake monitor but would require a different calibration to measure brake forces. The brake was set and released on each beam at least 5 times. Each time, there was a clear, unambiguous strain indication from the smart sensor. Figure 19 shows a typical strain history of a brake beam when the hand brake is released. The step in the strain measurement corresponds to a change of 75 microstrain difference in the brake beam when the brake is set versus its release. The brakes were set and released multiple times to ensure that the sensor's strain indication returned to the "zero" position each time. In this way, it was assured that the sensor was not slipping. These tests indicated that monitoring strain in a brake beam is a valid method for determining the status of the brake system.

A set of tests was performed to evaluate the reliability of the radio connections between the smart sensors underneath the railcars. Two types of antennas were tested. The first was a 2-inch dipole antenna which sticks out away from the sensor, and the second was a ceramic antenna surface mounted in the interior of the sensor itself. The dipole antenna, as was assumed, was the superior antenna. Equipped with the dipole antenna, the smart sensors could communicate up to two rail-car lengths away. The smart sensors with the integrated surface mounted antenna had difficulty communicating across one full car length. Obviously, this issue calls for further testing in order to determine the optimal antenna for this application.

The next series of tests was conducted to evaluate multiple sensors on a single railcar in a configuration that would measure brake forces on every wheel. Eight sensors were placed on the car to measure brake beam strains. Two routers were added for communications between cars. A schematic illustration of the installation is shown in Figure 20. Eight sensors would be needed to measure braking effort of each wheel. Only four sensors are needed to detect stuck brakes.

One of the sensors on each end of the car could also be configured to serve as a router to reduce the final cost of the system.

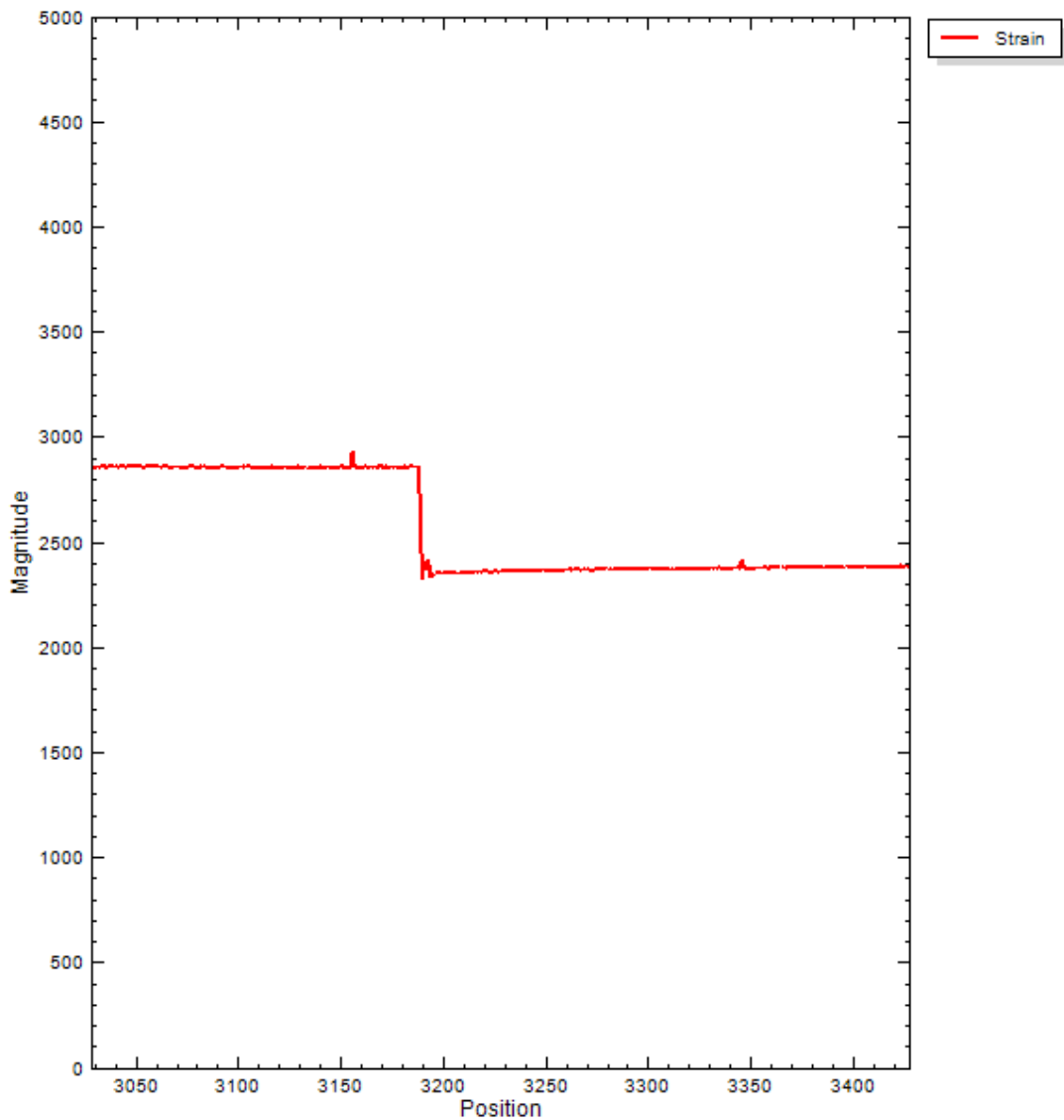

FIGURE 19 Sample data trace of hand brake release on brake beam at NS rail yard in Decatur, IL. The vertical axis is in A/D converter units and the trace corresponds to a step of 75 microstrain.

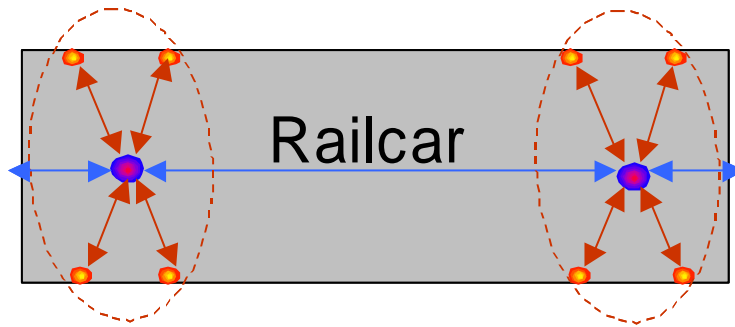

FIGURE 20 Railcar Sensors

A network consists of both sensors and routers. Physically one of the sensors is also a router so that no additional hardware is needed. Sensor nodes are configured in a star network and only communicate with other sensors and routers on the same railcar. This is configured during the initial installation. Each sensor has a unique 64 bit identification number. The network is configured to only accept identification numbers from a predefined list. Routers communicate with sensors on an individual railcar and routers on adjacent railcars. A mesh style network is used with the routers. Sensors were installed on each end of the four brake beams (8 per car). One router was enabled on each end of the railcar. This provides redundancy in case one router fails. Figure 21 shows the measured strains during a handbrake release.

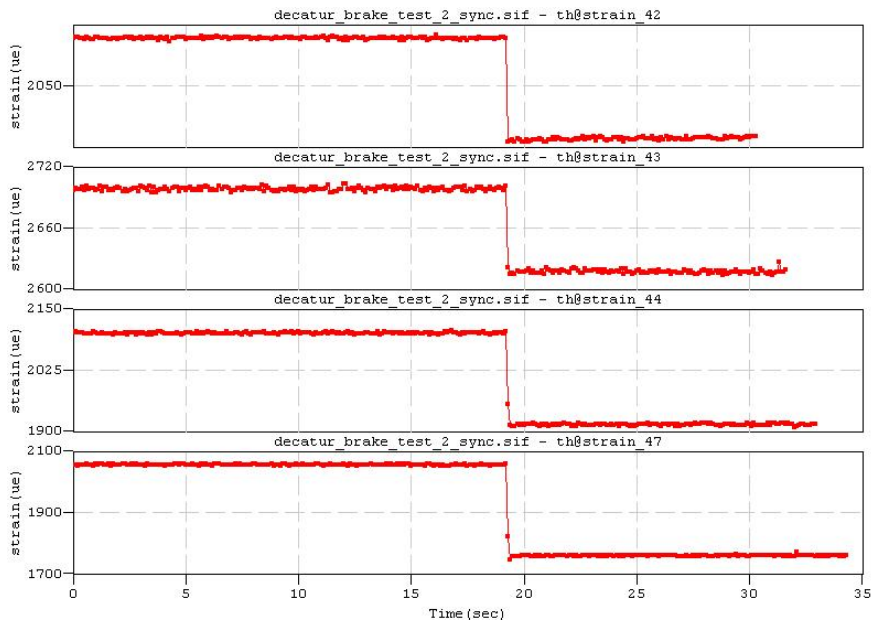

FIGURE 21 Measured strains during a handbrake release

The handbrake application produced about 200 microstrain in the brake beam. This is more than an order of magnitude larger than the resolution of the system. These tests demonstrated that there is sufficient signal strength to transmit information between sensors and routers and that the sensor system will work in a railcar environment.



FIGURE 22 Sensor installed on a rail flange

Electrical and magnetic interface is a well known issue in sensors and data acquisition systems. The following tests were conducted to determine the performance of the system in the electrical and magnetic fields typically found near a locomotive. The traction motor of a locomotive passing over a sensor system should be a severe test of the system. The sensor system was installed on the bottom flange of the rail as shown in Figure 22. The system is attached with a simple clamp activated with pointed set screws.

A small test train consisting of a locomotive and four cars was used for these tests. Both accelerations from the internal accelerometers embedded in the sensor and strains were measured. Data was streamed from the sensor to a gateway and finally to a nearby PC. Results from the strain sensor are shown in Figure 23.

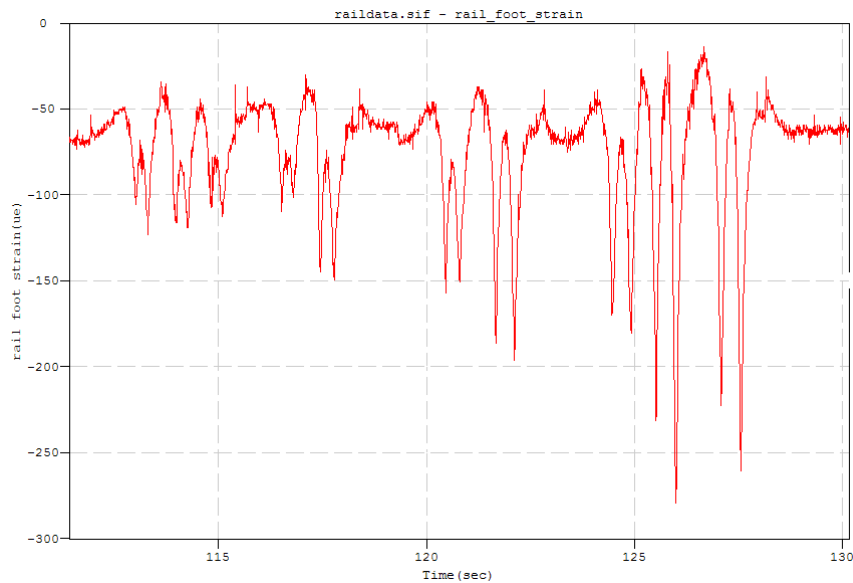

FIGURE 23 Measured Rail Strains

Strains for the passing of the locomotive are on the right side of the figure. The test data shows that the noise level in the sensor system is unaffected by the passing of the locomotive. The network was not interrupted by the locomotive passing over it. These tests demonstrate that the sensor system will work in the noisy environment of a locomotive.

Having established that a single railcar could be instrumented, a string of railcars was assembled to evaluate the radio network between cars. Two routing sensors were installed on each of 5 adjacent railcars on a brake beam on the front and

rear trucks. A Zigbee coordinator node was placed in an additional car to simulate the locomotive. A diagram of the network sensor placement is shown in Figure 24.

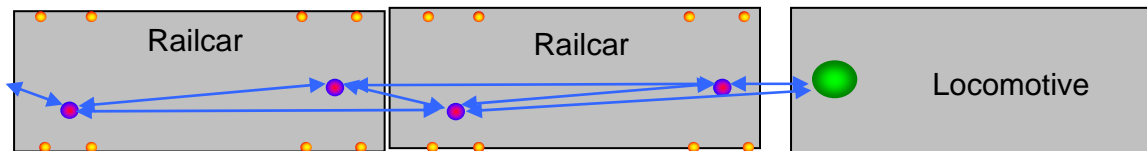

FIGURE 24. Sensor placement in network test

All of these sensors successfully joined the Zigbee network as indicated by the screen shot of the smart sensor control program shown in Figure 25. The control program can be deployed on a Windows PC or a PocketPC-based personal digital assistant (PDA). The application of the hand brake was easily detected on any of the five cars .

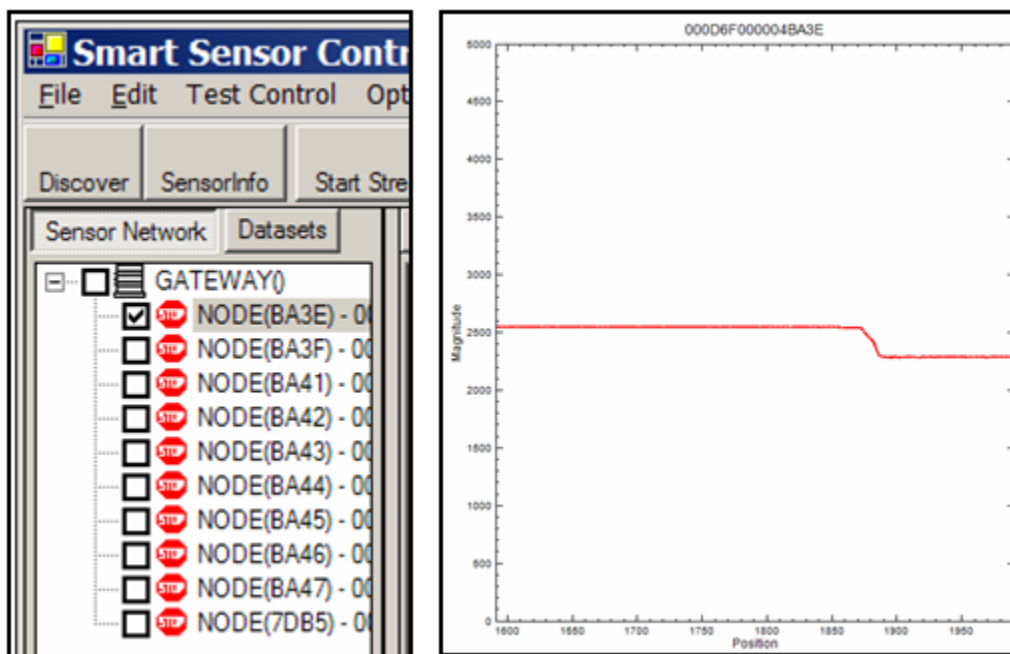

FIGURE 25 Node discovery and hand brake detection

Disabling a single radio node on any of the cars did not disable the network. There was enough redundancy that communication with all remaining sensors was maintained. Disabling both radio nodes on a car did, however, break the communication to cars away from the coordinator. Future work on radio strength and router placement should provide more redundancy.

A test was conducted to evaluate potential interference from other Zigbee networks that might be present in similarly-equipped passing trains. In the Zigbee protocol and the Ember software implementation, in particular, there are several conditions that must be present for two networks to clash:

1. Same Radio Channels
The Zigbee standard specifies 16 discrete radio frequency bands. A network is formed after an energy scan of all radio channels is performed. The least active channel is chosen for the new network.

2. Same PANID
Every Zigbee network is assigned a 16 bit identifier called a Personal Area Network Identifier (PANID). Two networks on the same channel should not conflict if they have different PANIDs.
3. Same Application Program IDs
A Zigbee application program can impose its own conditions to prevent unauthorized joining and communication with the network.

A second small Zigbee network consisting of a coordinator and 2 sensors was placed in the same general area as the five-car Zigbee network described in the previous section. Both networks operated on the same radio frequency band but each had unique PANIDs. No crosstalk between the networks was evident.

A final series of tests was conducted to evaluate the system in actual revenue service. Sensors were installed on trains running between fixed points, i.e., Detroit to St. Louis. Unfortunately the sensors were lost after six weeks of testing. This was most likely due to the mounting similar to that shown in Figure 22. Set screws were employed to hold the sensors in place. We suspect that the set screws vibrated loose sometime during the tests. We have not observed this problem during any of our other tests. The set screw mounting was always considered a temporary measure to facilitate our testing. Permanent installation will be with stud welds or tapped holes.

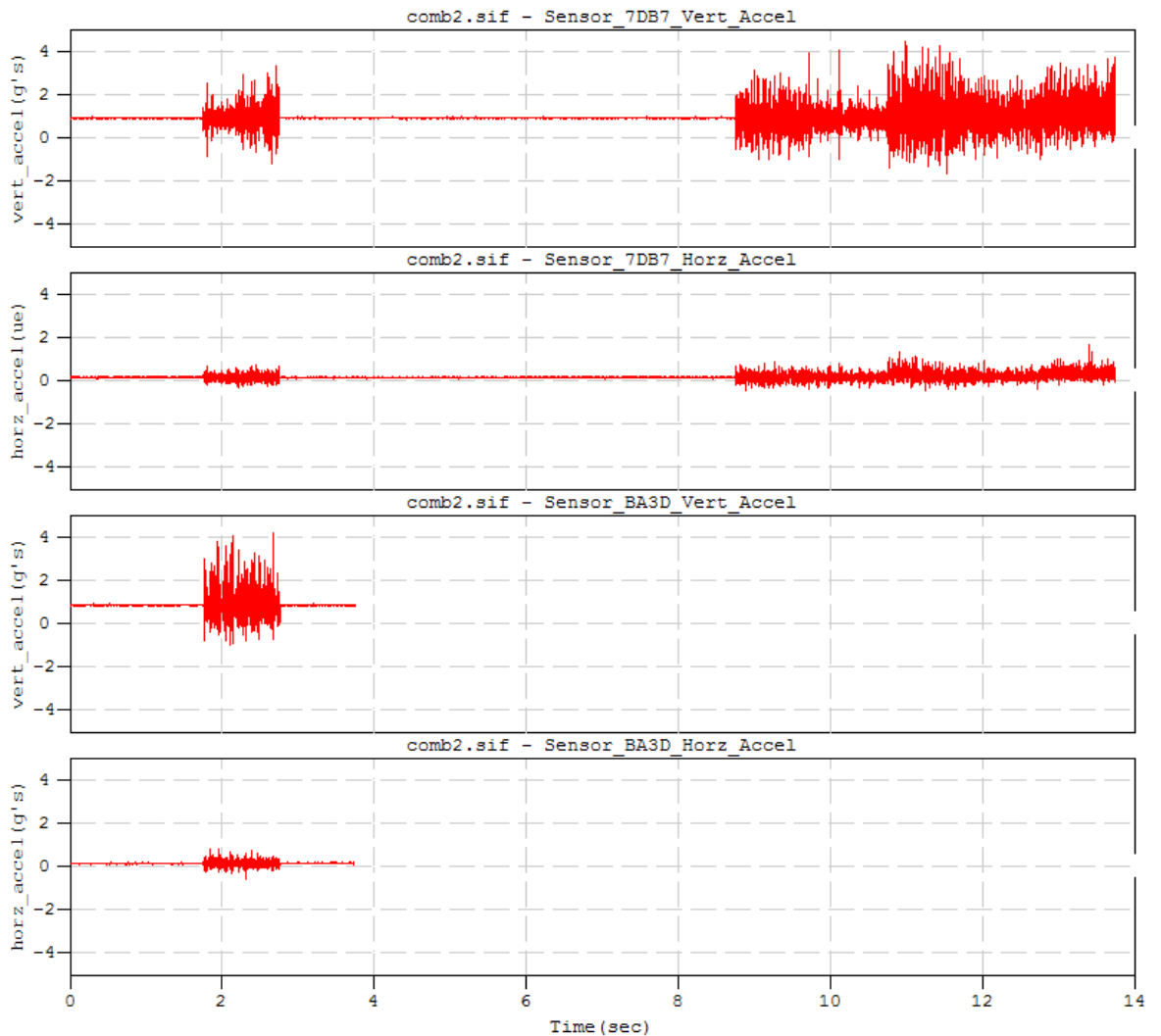

FIGURE 26 Vibration test data from revenue service tests

These tests were repeated with sensors that were directly bolted to the brake beam, see Figure 2. These tests were conducted on a railcar that was in continuous service between Indianapolis and Buffalo. This car was part of an AAR test program for evaluating the performance of a new frog design. The purpose of these tests was twofold. Evaluate the mechanical and electrical durability of the sensor system and to characterize the vibration environment so that an energy harvester can be designed for this specific application. Five sensor systems were installed on a covered hopper car. The car was in service for more than 3 months and travelled a total of about 25,000 miles. The prototype sensors did not have enough internal power or memory for such long tests. The vibration environment was also unknown, so an energy harvester could not be employed to power the system. We developed a special set of testing software to overcome these limitations. Remember that the purpose of these tests was not to demonstrate that brake beam forces can be measured, that had already been established. These tests were for evaluation of the longer-term performance in revenue service. To reduce the amount of data collected, only one second of data was recorded every hour. A sample of the data is shown in Figure 26. The top two charts show sensors that were removed from the railcar after 3 months in service. The bottom two charts show data from sensors that were removed after 6 weeks. The data represents both vertical and lateral acceleration of the brake beam sensor.

There was no power to the sensors when they were removed, but all sensors worked when the batteries were recharged. Since the sensors worked when powered up we infer that they also would have worked if they had been continuously powered. Also when we compare the data between the top and bottom charts, we note that there was no corruption of the data in the sensors that were left on the railcar for a longer time. From these tests we conclude that the sensors have adequate mechanical and electrical durability.

An FFT of the vibration data is shown in Figure 27. It shows that the natural frequency of the brake beam is around 120 Hz. This is consistent with the data reported by Ludlow et.al. (Chris C. Ludlow, Marthinus van Schoor and Tim Gipson, "Self Powered Wireless Brake Shoe Force Measurement System for Train Brakes," JRC2006-94034, Proceedings of JRC Joint Rail Conference, April 2006, Atlanta, GA). However the vibration levels are an order of magnitude lower than they report.

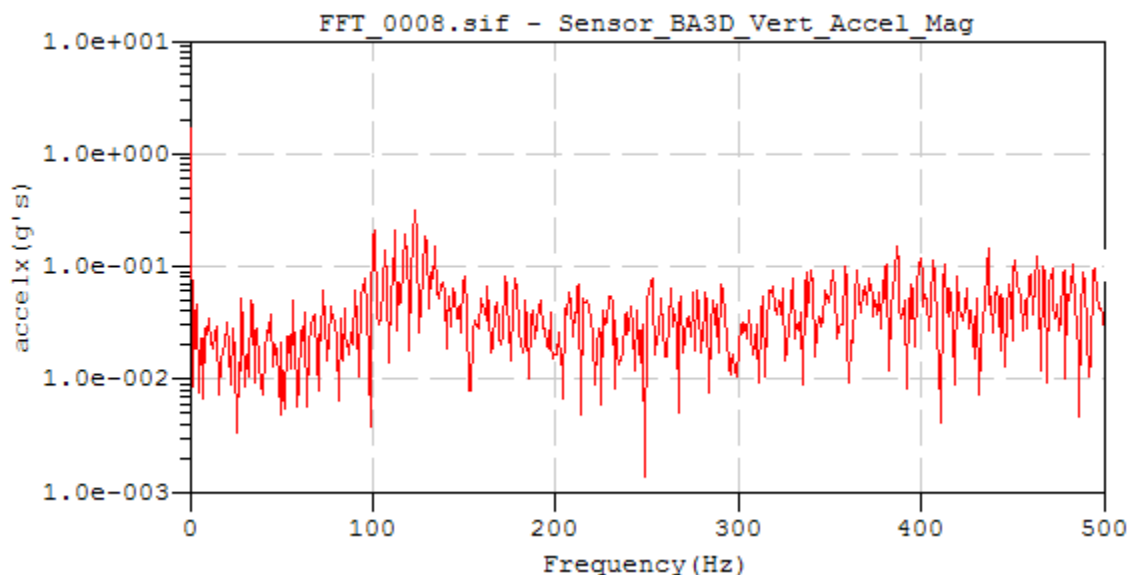

FIGURE 27 Frequency content of brake beam vibration

PROJECT PANEL

An expert panel was established to provide guidance for this project. The panel met on August 16 ,2006 to review the program and establish a testing plan. Panel members included: Gary Nelson of NS, Henry Lees of BNSF, and Keith Hawthorne of AAR.

As a result of extensive discussions the following test plan was suggested by the panel. It was agreed that the testing plan is ambitious and not all of the tests can be conducted within the scope of this project.

Five sets of tests will be performed on the smart sensors. Gary Nelson of Norfolk Southern kindly agreed to provide access to the necessary railcars.

1. Single car

The purpose of these tests is to demonstrate the system on a single railcar. Eight sensors will be placed on the car to measure brake beam strains. Two additional sensors will be placed on adjacent cars to form a simple network. In addition to demonstrating system performance, tests will be conducted to establish threshold detection levels.

2. Locomotive

These tests will be conducted to determine the performance of the system in the electrical and magnetic fields typically found in a locomotive.

3. String of cars

A string of railcars will be assembled to evaluate the radio network. Approximately twenty- five cars will be instrumented with a single sensor per car. Tests will be conducted with a variety of router placements. Robustness of the network and propagation delays will be evaluated.

4. Network forming

These tests will be conducted to simulate adding and subtracting cars from a train network. Cars will be instrumented with a single sensor. Networks will be set up to simulate multiple trains. Interference from other networks will be simulated in these tests.

5. Over the road service

The purpose of these tests is to evaluate the robustness and durability of the sensors and network. Sensors will be installed on trains running between fixed points, say Detroit to St. Louis.

- a. brake tests - A few cars will be instrumented with single sensors. These sensors will be programmed to measure and record brake events. Then the data will be compared with the data from the locomotive. We want to demonstrate that all brake events are recorded and that no false positives occur.
- b. radio test - A small network of two or three sensors will be established. Each sensor will send a message on a fixed time increment, say 1 second, to all other sensors. Special software will be installed to log these messages. We want to insure that the network functions for the full duration of the test and that the network is not activated by some extraneous event.
- c. vibration test – The sensors have built in accelerometers. Special software will be installed in the sensors to characterize the vibration environment so that appropriate energy harvesters can be built.
- d. energy harvester – Energy harvesters will be installed on the train. Both those of our design and ones commercially available will be evaluated. A sensor will set to record, in histogram format, the actual power generated.
- e. strain measurement – Some sensors will be installed to record the strain history to evaluate the robustness of the strain measurement system.

All of the tests except 5a and 5d were completed during this project. Including these two tests would have resulted in additional costs not covered in the project budget. Further development of this concept should, however, include such tests.

FINDINGS AND CONCLUSIONS:

We have successfully demonstrated a sensor system that will measure brake beam forces on railcars in revenue service. We believe that, by using consumer product technologies, total system costs can be kept to a minimum. At this point each sensor can be manufactured in lot sizes of 25 for under \$60. This can be further reduced with automated manufacturing and large lot sizes. Four sensors will be required for each railcar, so costs per car, including labor, would be under \$250. The Zigbee network met all expectations and we established that it will work in a rail environment. We

have also established a process for designing a low-cost power harvester. However we do not know the wide spectrum of vibration environments that a railcar would encounter in service. This information will be required for a specific energy harvester design.

PLANS FOR IMPLEMENTATION

The smart sensor system has generated considerable interest in the railroad industry. One immediate application is in monitoring the failure of insulated joints. A photo of a smart sensor attached to an insulated joint is shown in Figure 28. A number of sensor systems have been produced for field testing at TTCI. The sensors will measure longitudinal forces caused by thermal loading of the rail. Delamination of the joint bars causes a perturbation in the stress field, thus allowing a failing joint to be detected.



FIGURE 28 Sensor installed on an insulated joint

We received an enquiry from AAR about incorporating our sensors into the hand brake chain to detect hand brakes that were still applied when the railcar begins to move. The proposed sensor is shown in figure 29. Power is not an issue with this system so that batteries may be used. In addition to detecting the force, the location of the railcar is needed. This involves adding GPS to the sensor system.

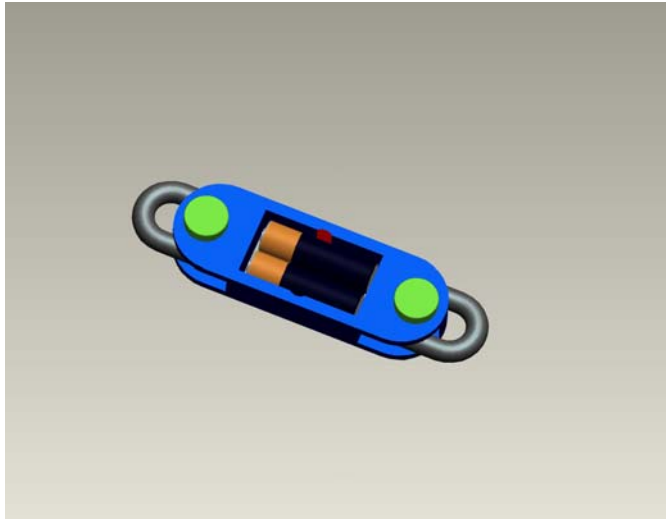

FIGURE 29 Proposed instrumented chain link

Finally, we produced a number of prototype sensor systems for a data acquisition company, SoMat, to evaluate with their eDaq product line. SoMat products have been extensively used in the rail industry.

INVESTIGATOR PROFILE

Darrell Socie
Professor Emeritus
Mechanical Science and Engineering
University of Illinois at Urbana-Champaign
Urbana, Illinois 61801

Dr. Socie's early research work at the University of Illinois involved the development of fatigue life estimation models for notched and cracked members subjected to variable amplitude loading. He was responsible for the development of ASTM Standard E 1049 Cycle Counting in Fatigue Analysis. This was followed by ten years work studying cyclic deformation of and fatigue of metals under multiaxial states of stress. Although retired, Prof. Socie still maintains an active research program. Current research includes cyclic deformation and fatigue under multiaxial stresses, probabilistic fatigue and fracture design, energy harvesting and structural health monitoring.

Dr. Socie worked as a consulting engineer for Structural Dynamics Research Corporation prior to joining the University of Illinois and has remained active in industrial consulting on fatigue and fracture related problems. In addition to problem solving and failure analysis, he has conducted design reviews for many manufacturing companies. He has been teaching industrial short courses in the USA, Europe, China and Japan for more than 25 years. Prof. Socie received the Commanders Award for Distinguished Public Service from the US Army for his work on pipeline failures. He has been active in small businesses and is one of the founders of SoMat Corporation, a manufacturer of data acquisition and analysis systems. He is responsible for growing the business to \$5M annual revenues before its sale to AEA Technology in 2001. eFatigue LLC, a company that develops web based engineering analysis software, and BBM Plus, a consulting company have also been started by Prof. Socie.

Christopher P.L. Barkan
Associate Professor
Director - Railroad Engineering Program
University of Illinois at Urbana-Champaign

Christopher P.L. Barkan is Associate Professor and Director of the Railroad Engineering Program at the University of Illinois at Urbana-Champaign (UIUC). Barkan has principal responsibility for direction and coordination of the rail research program, and development and teaching of the university's railroad engineering academic program. Barkan also serves as the director of the Association of American Railroads (AAR) Affiliated Laboratory at UIUC and maintains frequent contact, coordination and collaboration with the railroad research staff at the Transportation Technology Center, Inc. in Pueblo, CO and with the Safety & Operations staff at the AAR. Barkan also serves as Deputy Director of the RSI-AAR Railroad Tank Car Safety Research and Test Project, a long-term, cooperative effort of the North American railroad and tank car industries conducting research to improve railroad tank car safety.

Dr. Barkan's research is focused on railroad safety and risk analyses with particular emphasis on derailment prevention, tank car design and hazardous materials. Barkan has been organizer or co-organizer of workshops on new technologies for detection of broken railroad rails, railroad applications of NDT, railroad hazardous materials transportation risk analysis, and location referencing systems for Positive Train Control. Barkan is principal organizer of the annual Railroad Environmental Conference and of the Risk Management Session in the annual AAR Hazardous Materials Seminar.

Barkan is the chairman of the Executive Board of the Rail Group of the Transportation Research Board (TRB). He was a member of the TRB Committee on Transportation of Hazardous Materials from 1993-2002 and remains active as an associate, and has been a member on the TRB Committee on Railroad Track Structure System Design since 1999. He is a member of two American Railway and Engineering and Maintenance of Way Association (AREMA) committees, and several other professional railway organizations. In 2002 he was an invited member of the GAO Special Panel on Safety of Hazardous Materials Transport by Rail and is currently serving as an invite member on the TRB panel evaluating the feasibility of a hazardous materials transportation cooperative research program.

Prior to assuming his current position at UIUC, Barkan was Director of Risk Engineering at the AAR where he had principal responsibility for directing the North American railroad industry's research programs on risk analysis, tank car

and hazardous materials transportation safety, pollution prevention & environmental technologies. Dr. Barkan holds an undergraduate degree from Goddard College (1977) and graduate degrees from the State University of New York at Albany (M.S., 1984; Ph.D., 1987) where he conducted research on environmental applications of stochastic optimization models. He held a postdoctoral research fellowship at the Smithsonian Institution Environmental Research Center before joining the AAR Research and Test Department in 1988. Barkan is an author or editor of over 40 papers, reports or books on railroad risk, hazardous materials, tank car safety and environmental subjects.