

# Development of Traffic and Truck Traffic Pattern Groups for the Primary Road Network in Costa Rica

Henry Hernandez-Vega, LanammeUCR, Universidad de Costa Rica

Javier Magana-Cubillo, Universidad de Costa Rica

Jonathan Regehr, Department of Civil Engineering, University of Manitoba

NATMEC: Improving Traffic Data Collection, Analysis, and Use 2016

May 1-4, 2016

Miami, Florida

*Organized by*

Transportation Research Board

# About Costa Rica



# About Costa Rica



51 000 sq km

Population: 4.5 million

Motorized vehicles: 1.2 million

National Road Network: 7 800 km





# About Costa Rica

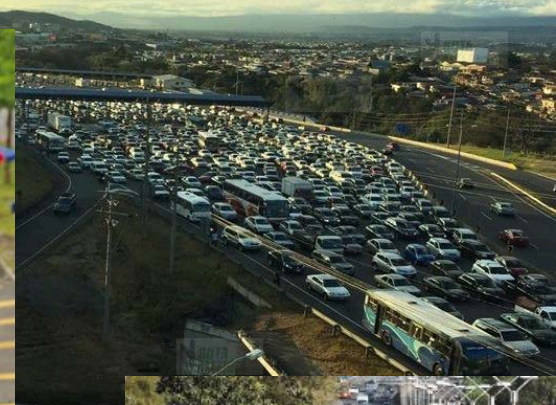

# Introduction



# Introduction

- Traffic Monitoring has a **cost**.
- Most counts in Costa Rica are **short term counts**.
- It is assumed that these counts represent **longer periods**.
- **Limited knowledge** related to temporal variations of traffic in Costa Rica.

# Introduction

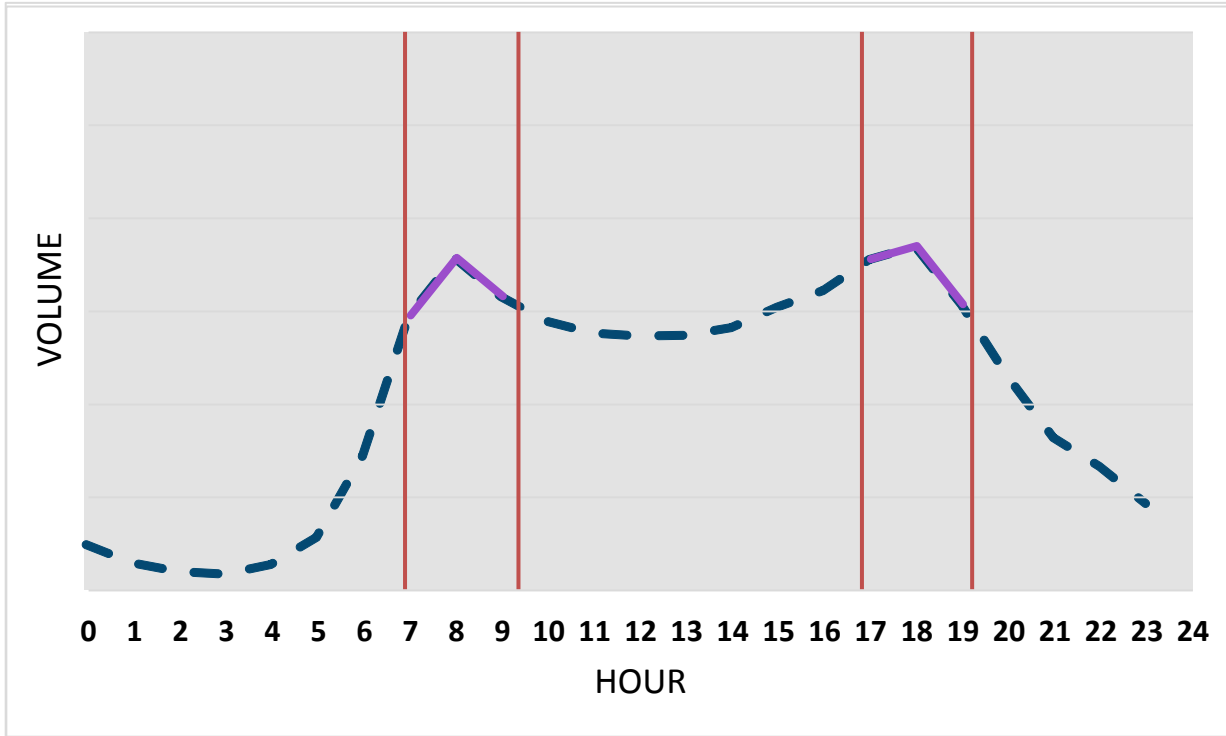

Adjustment factors and expansion of traffic volume from short term counts

# Introduction

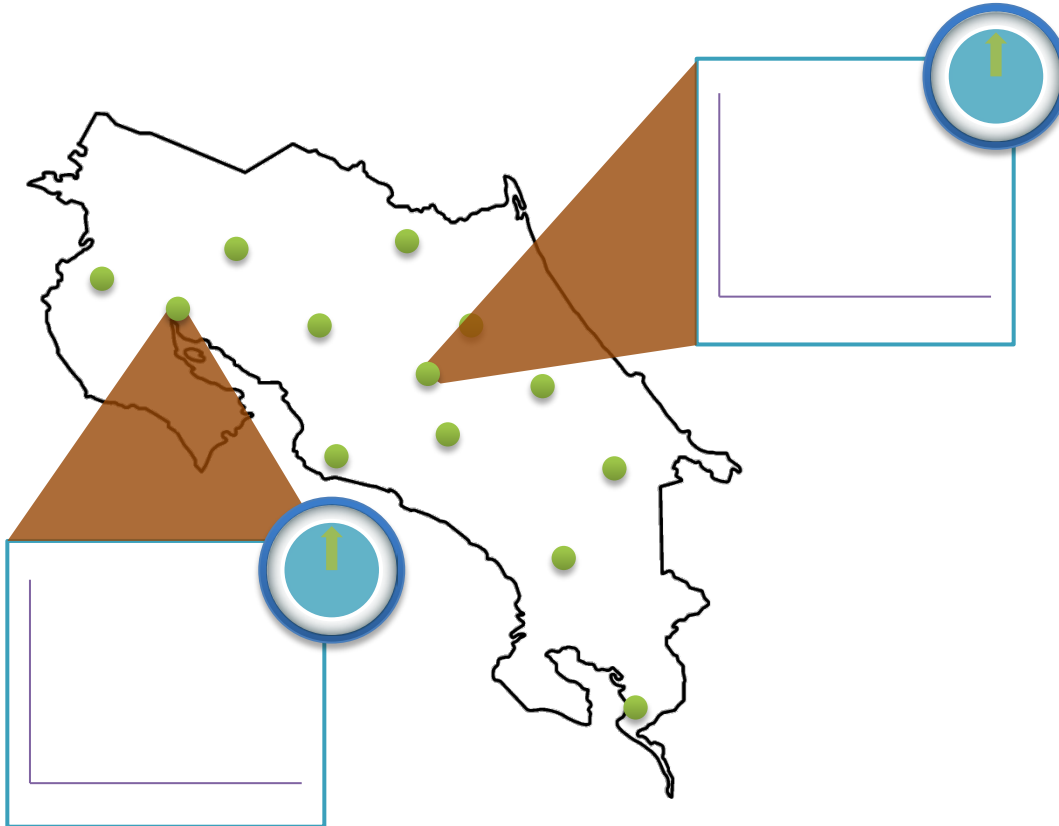

In Costa Rica there is **detailed traffic information** at some points of the road network.

The knowledge of **temporal variations of traffic by TOD, DOW and by Month** is fundamental.



# Introduction



Need to create:

- road groups with similarities on temporal traffic variations
- tools that improve the decision-making process

# Objectives

Determine Traffic  
Pattern Groups

Data Quality Assurance

Determine and explain typical patterns on permanent stations. For example, typical weekdays

Cluster analysis and geographical evaluation (Hybrid approach)

Temporal factors for each Traffic Pattern Group (TPG)

# Methodology

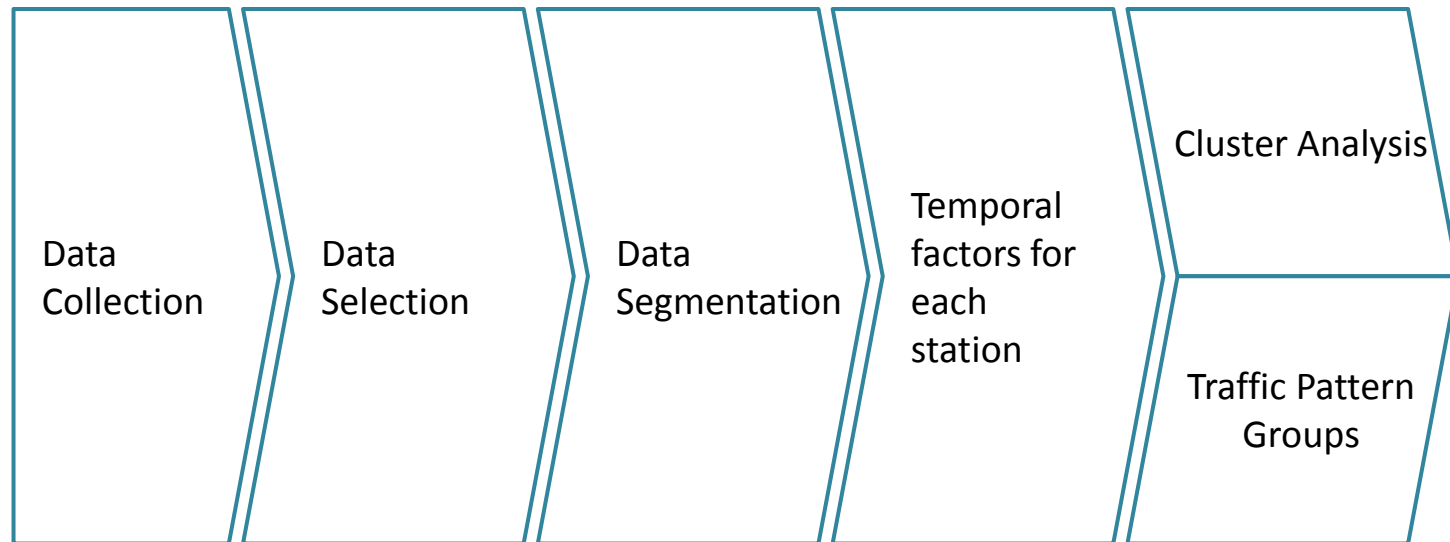

# Data Sources



Transportation  
Ministry  
(MOPT)



Highway 27



PITRA–  
LANAMME  
UCR

# Data Sources

Transportation Ministry

Highway 27

PITRA-LANAMME UCR

Permanent Counters: Road Tubes

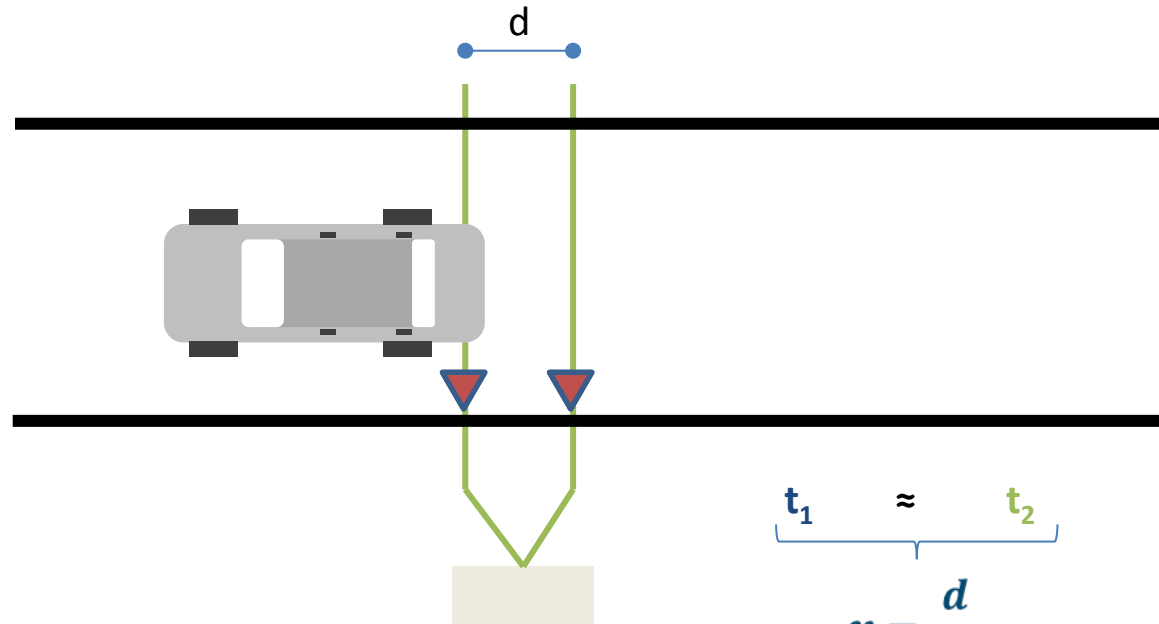

$$v = \frac{d}{t}$$



# Data Sources

Transportation  
Ministry

Highway 27

PITRA-LANAMME  
UCR

Road Tubes

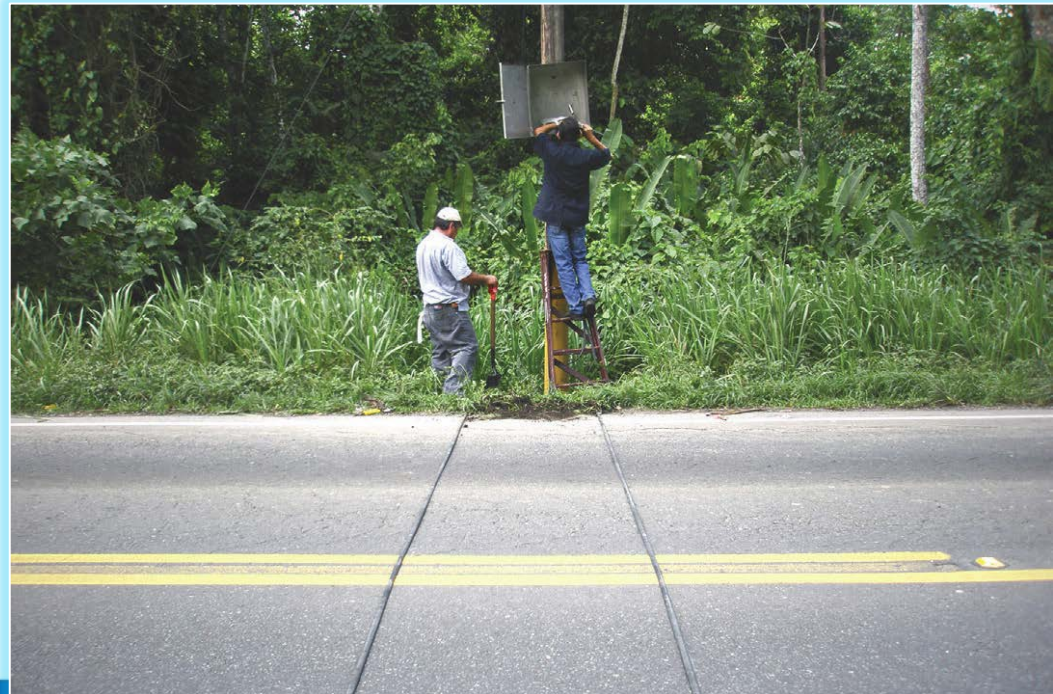

# Data Sources

Transportation Ministry

Highway 27

PITRA-LANAMME UCR

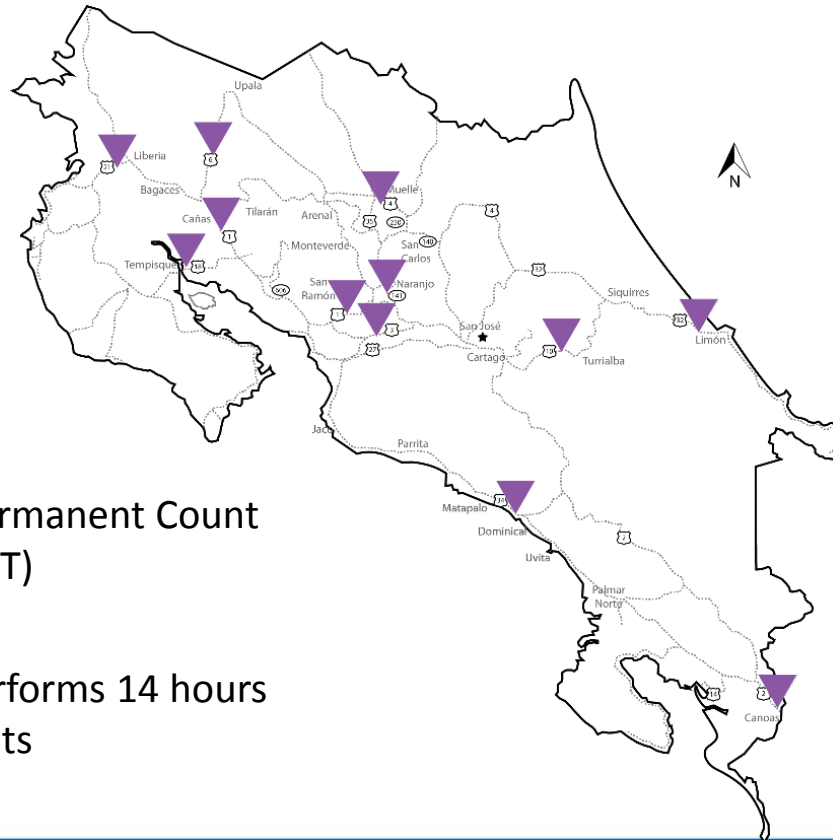

Location of Permanent Count Stations (MOPT)

MOPT also performs 14 hours coverage counts

# Data Sources

Transportation  
Ministry

Highway 27

PITRA-LANAMME  
UCR

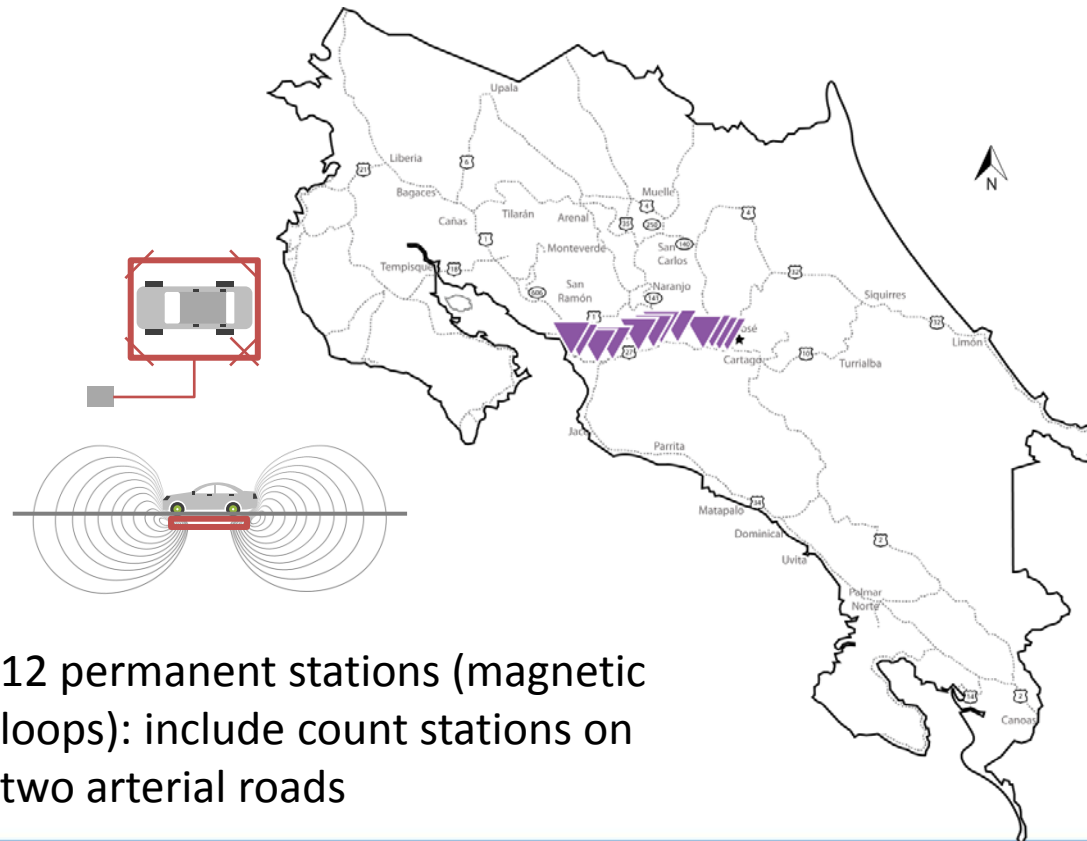

12 permanent stations (magnetic loops): include count stations on two arterial roads

# Data Sources

Transportation  
Ministry

Highway 27

PITRA-LANAMME  
UCR

32 locations

Duration between 2 and 10 days

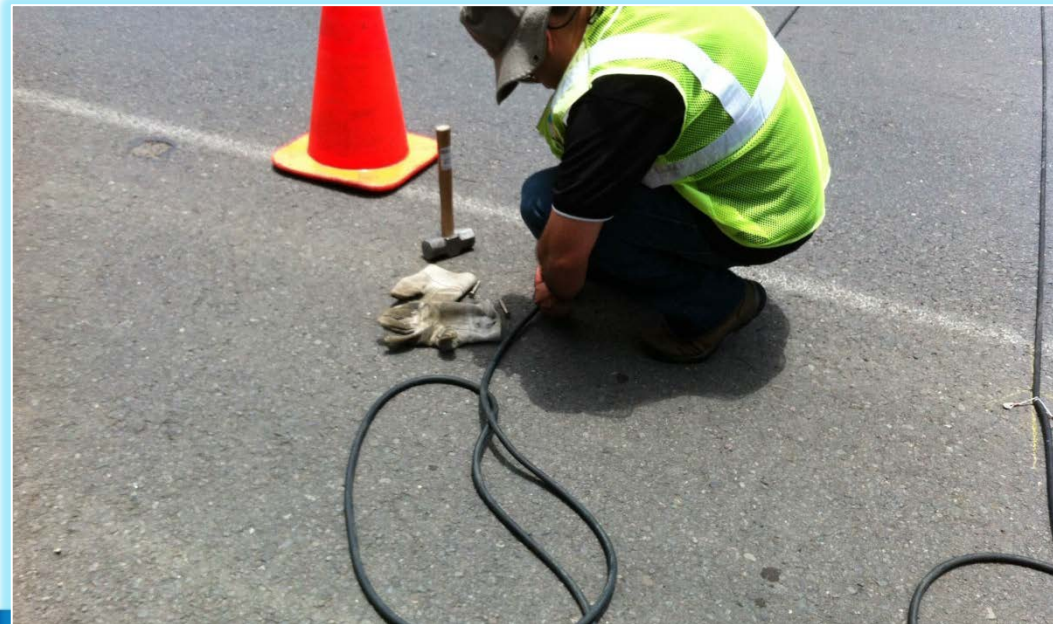

# Data Sources

Transportation Ministry

Highway 27

PITRA-LANAMME UCR

Road Tubes  
Duration between 2 and 10 days

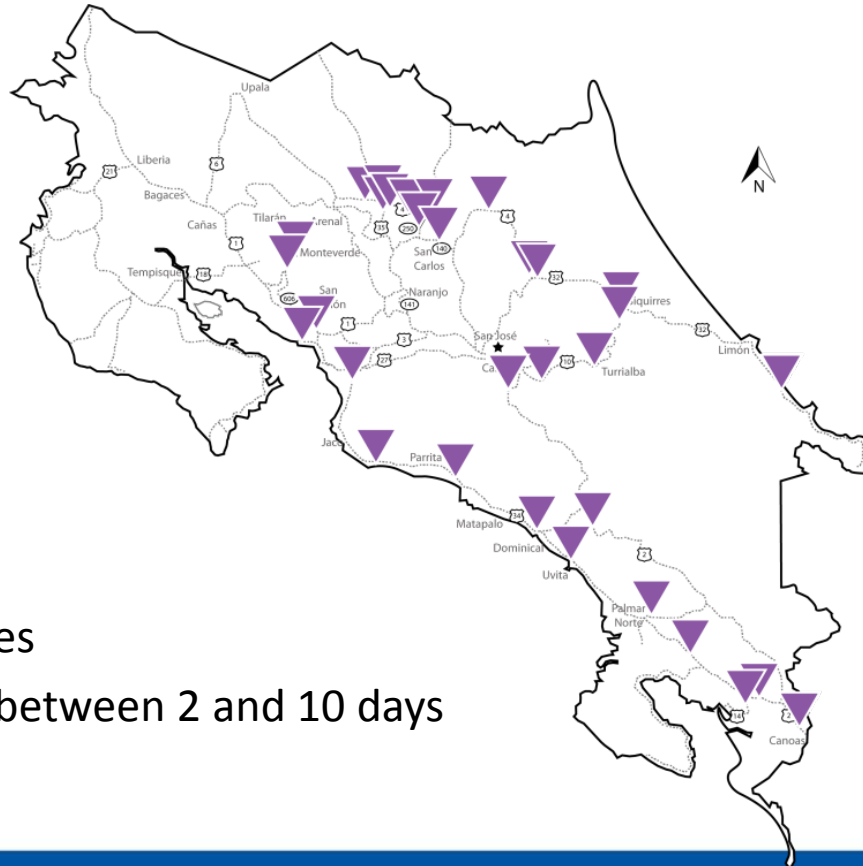



# Data Sources

Transportation  
Ministry

Highway 27

PITRA-LANAMME  
UCR

Only days with 24-hour data were selected to determine HOD factors for each permanent count station.

# Classification

**Total.** All vehicles.

**Type 1.** Passenger cars and motorcycles.

**Type 2.** Buses.

**Type 3.** Single unit trucks.

**Type 4.** Articulated trucks.

Type 1



Type 2

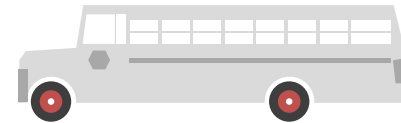

Type 3



Type 4



# HOD Factors

0-1	1-2	2-3	3-4	4-5	5-6	6-7	7-8	8-9	9-10	10-11	11-12	12-13	13-14	14-15	15-16	16-17	17-18	18-19	19-20	20-21	21-22	22-23	23-24	Σ Día
657	408	185	128	145	362	1156	2850	4434	3457	2965	3105	3515	3539	3422	3611	4034	4716	5405	4481	3154	2412	1647	1196	60984

$$FH_i = \frac{(VH_i)_P}{(VD)_P} = \frac{4434}{60984} = 0,073 \approx 7,3\%$$

0-1	1-2	2-3	3-4	4-5	5-6	6-7	7-8	8-9	9-10	10-11	11-12	12-13	13-14	14-15	15-16	16-17	17-18	18-19	19-20	20-21	21-22	22-23	23-24
0,011	0,007	0,003	0,002	0,002	0,006	0,019	0,047	0,073	0,057	0,049	0,051	0,058	0,058	0,056	0,059	0,066	0,077	0,089	0,073	0,052	0,040	0,027	0,020

# DOW Factors

	SUN	MON	TUE	WED	THU	FRI	SAT	TPDS WADT
JANUARY	52222	67094	72840	73716	74075	79987	65994	69418

$$FD_{n,m} = \frac{(TPDS_n)_{m,P}}{TPDS_{m,P}} = \frac{67094}{69418} = 0,967$$

	SUN	MON	TUE	WED	THU	FRI	SAT
JANUARY	0,752	0,967	1,049	1,062	1,067	1,152	0,951

# Cluster Analysis

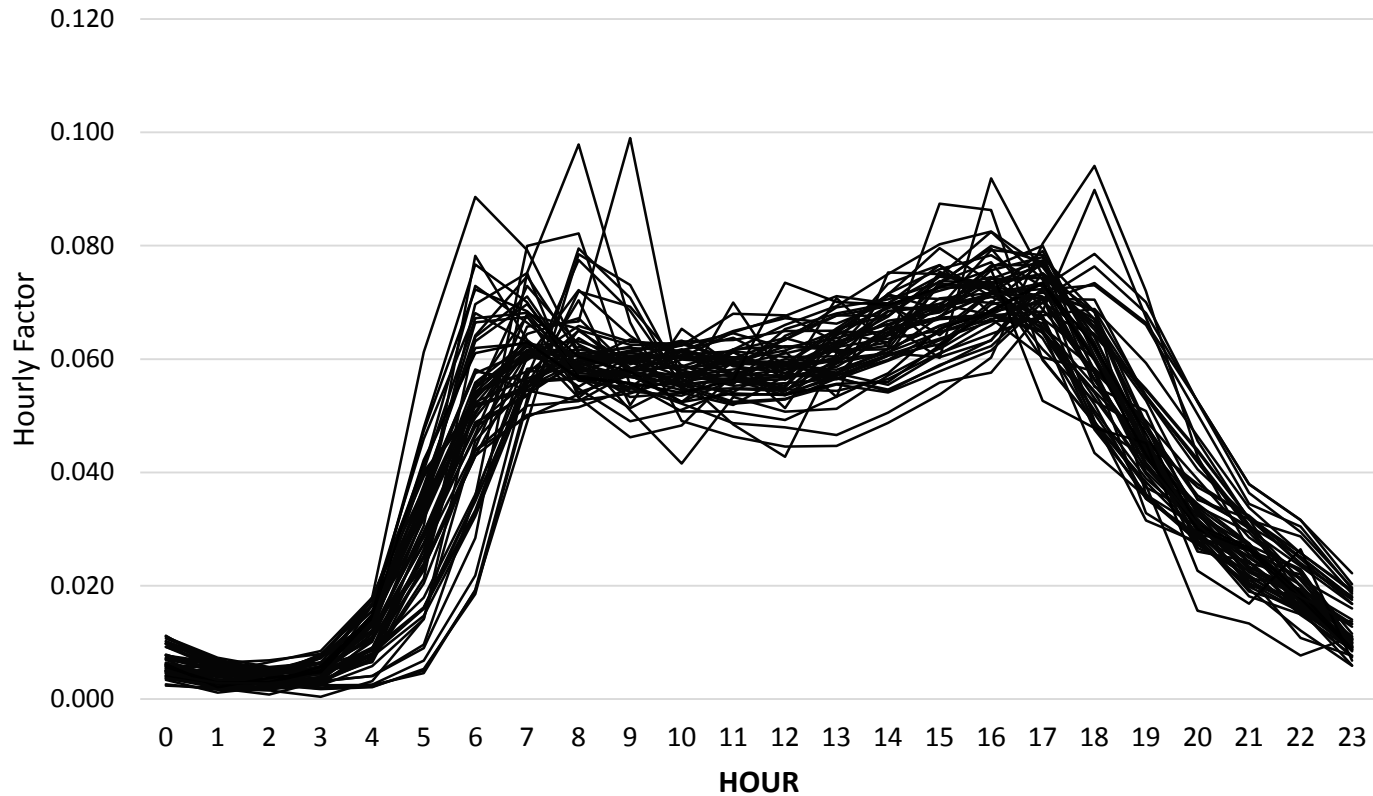



# Cluster Analysis

Initial Number of Groups = 10

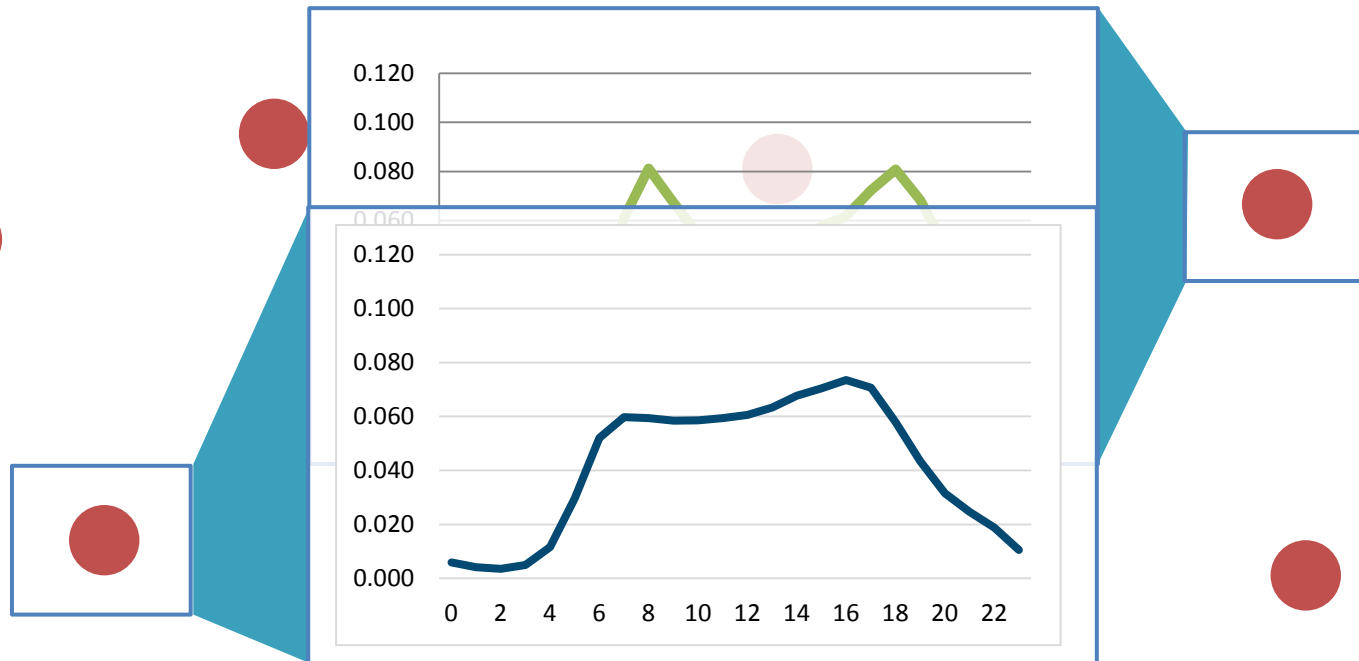

# Cluster Analysis

Number of Groups = 10

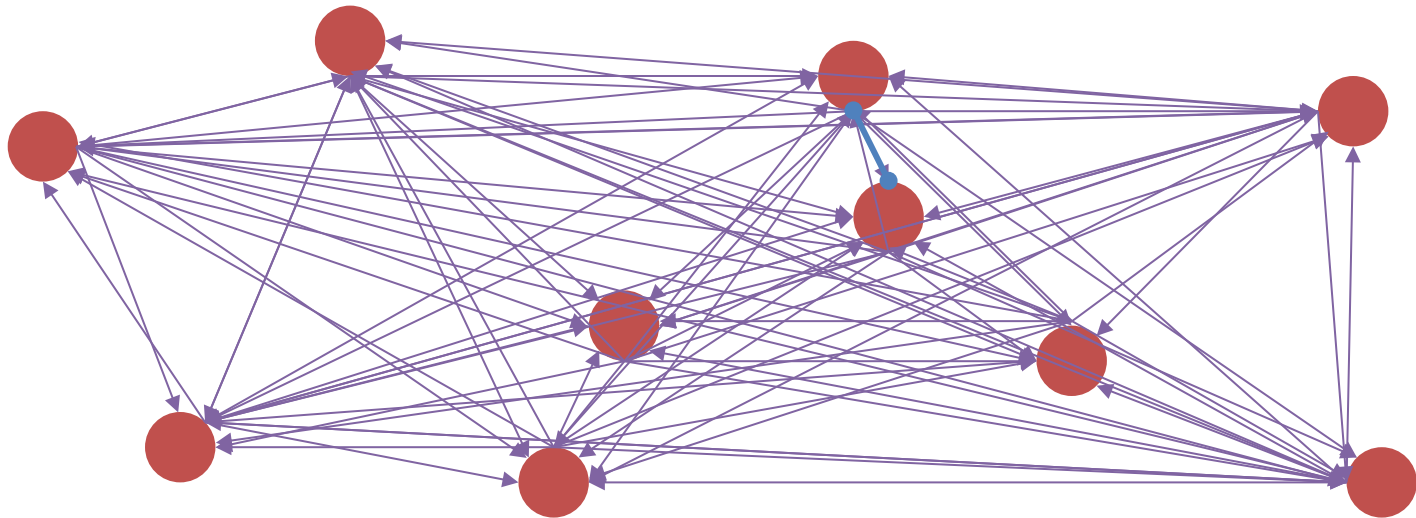

# Cluster Analysis

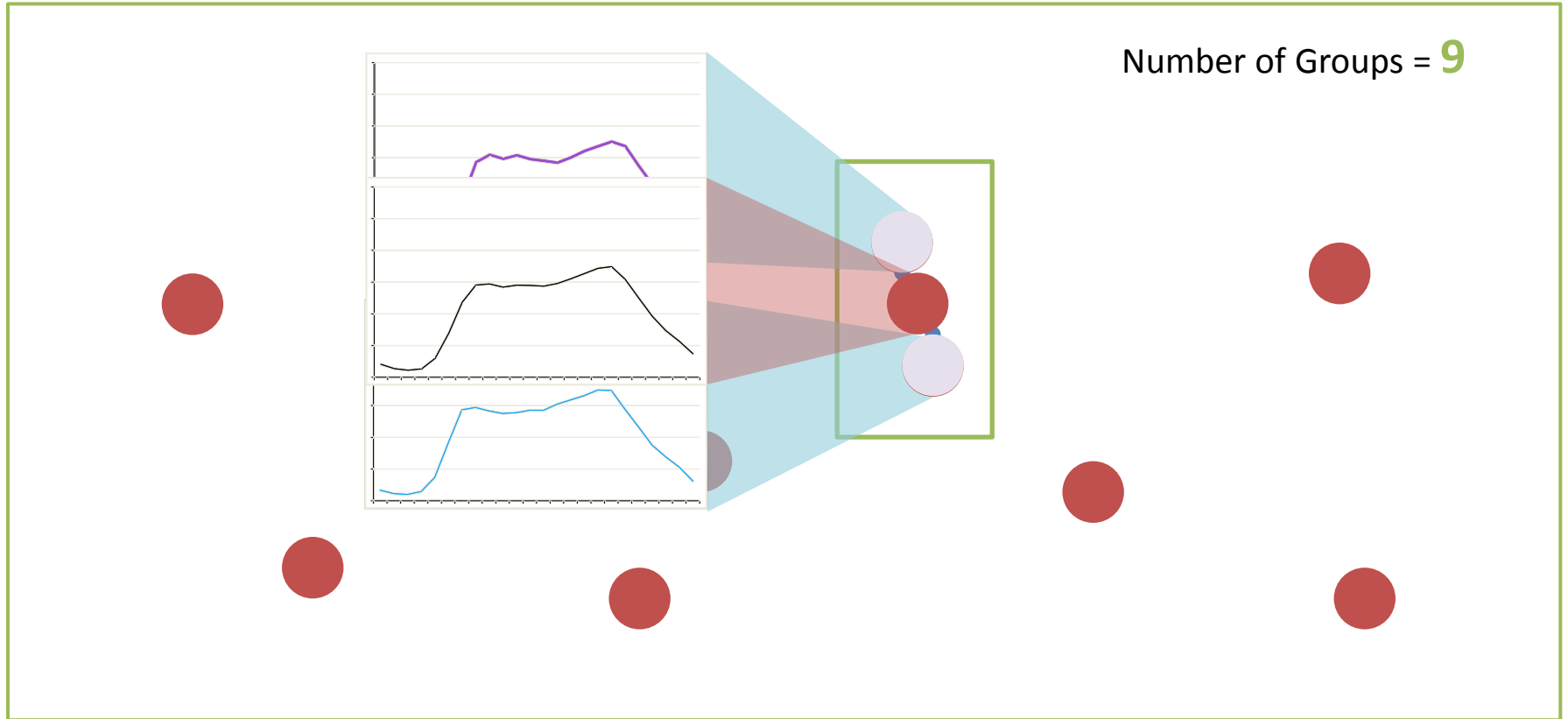

# Cluster Analysis

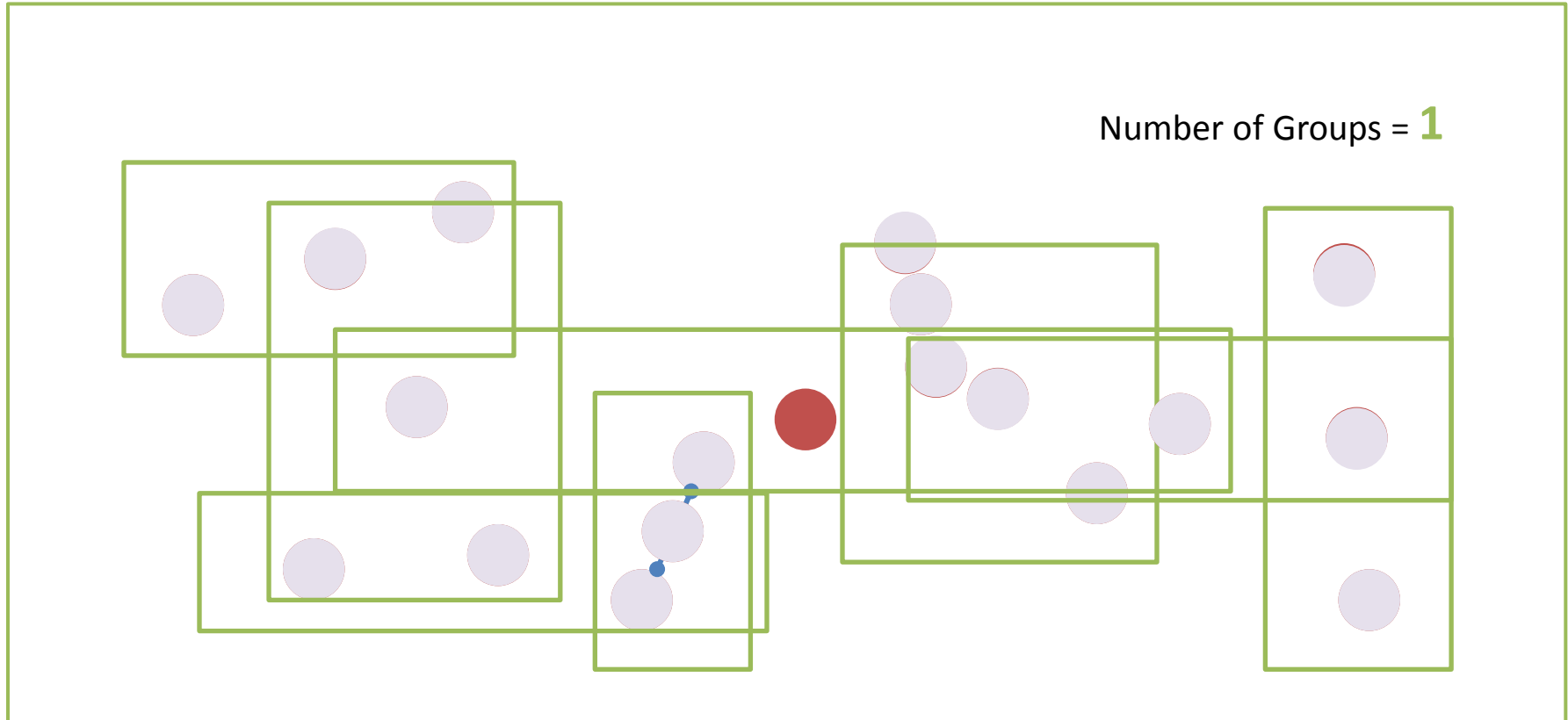

# Cluster Analysis

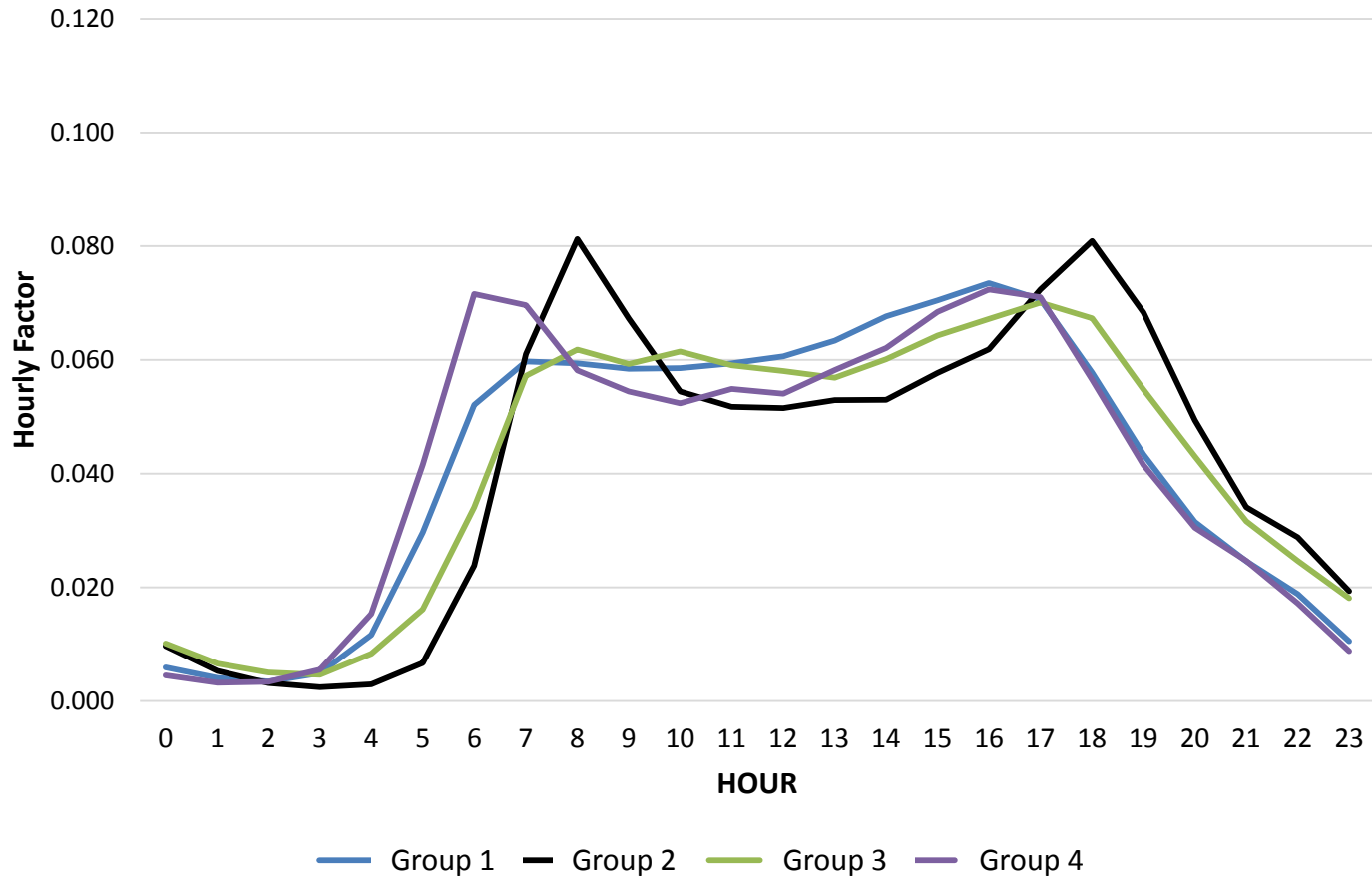

# Cluster Analysis

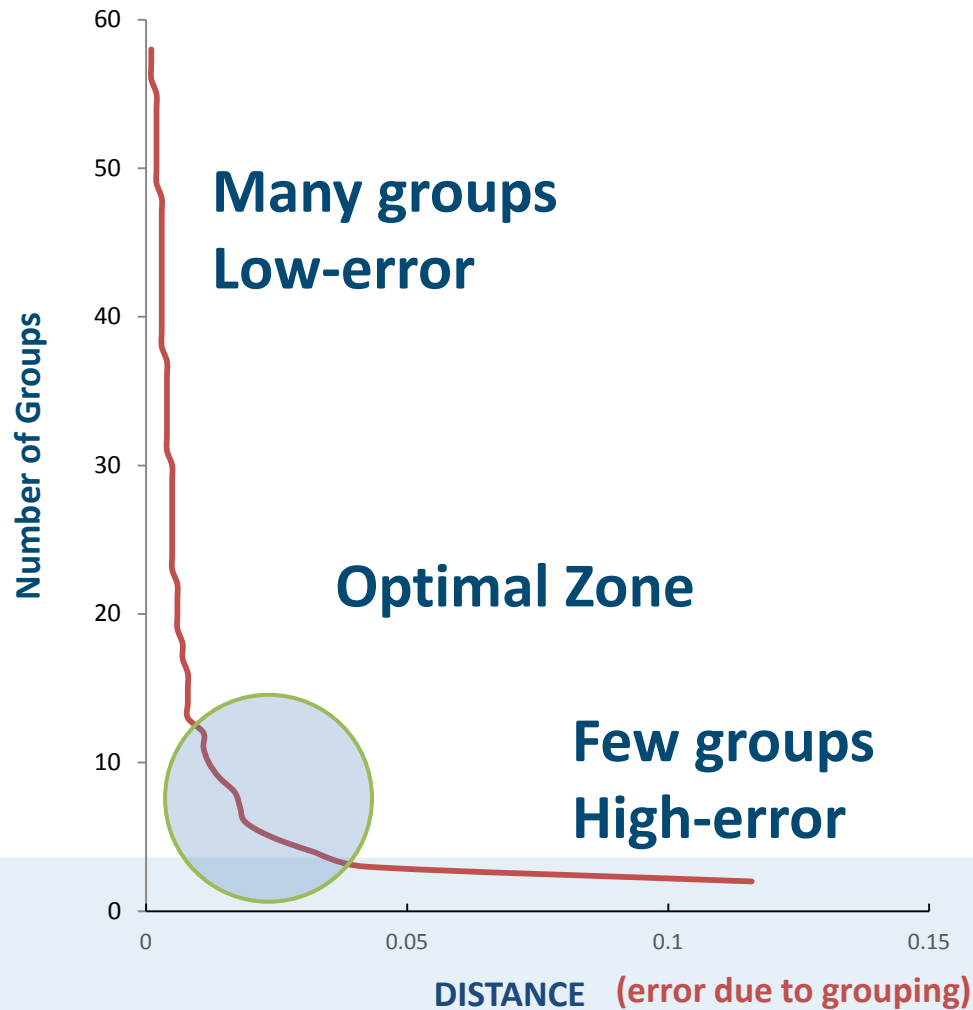

# Cluster Analysis

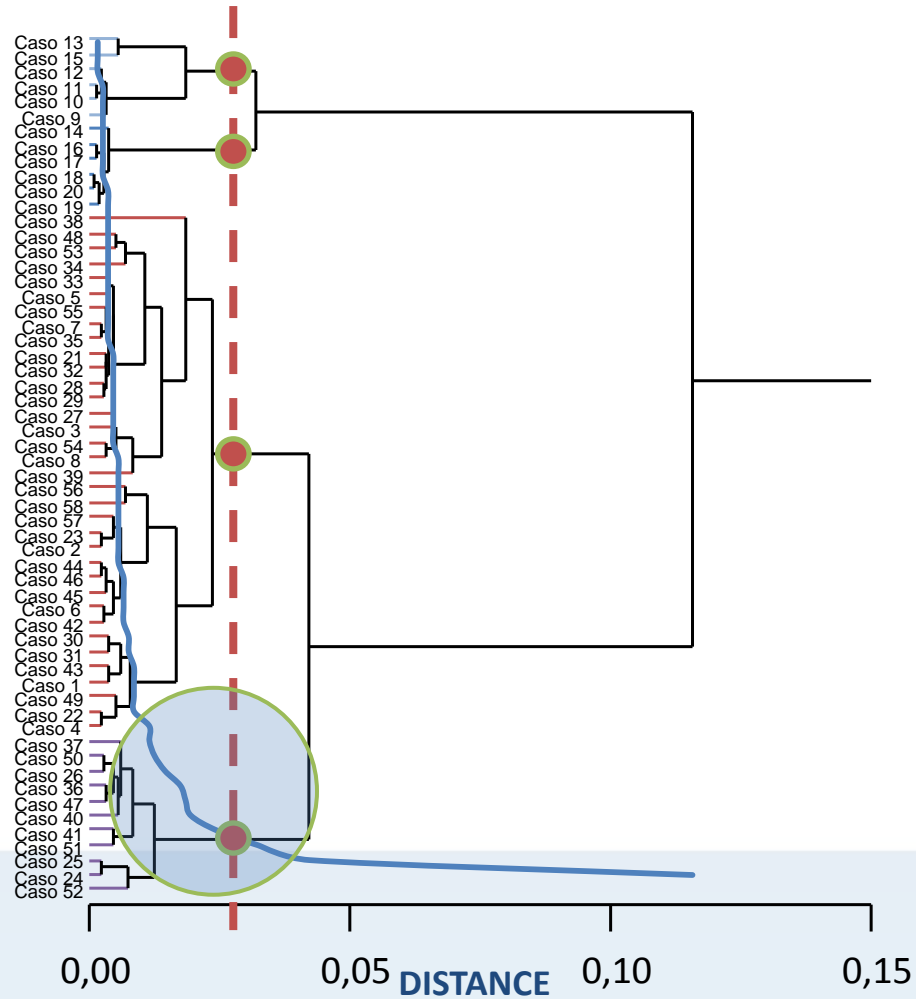

# Cluster Analysis

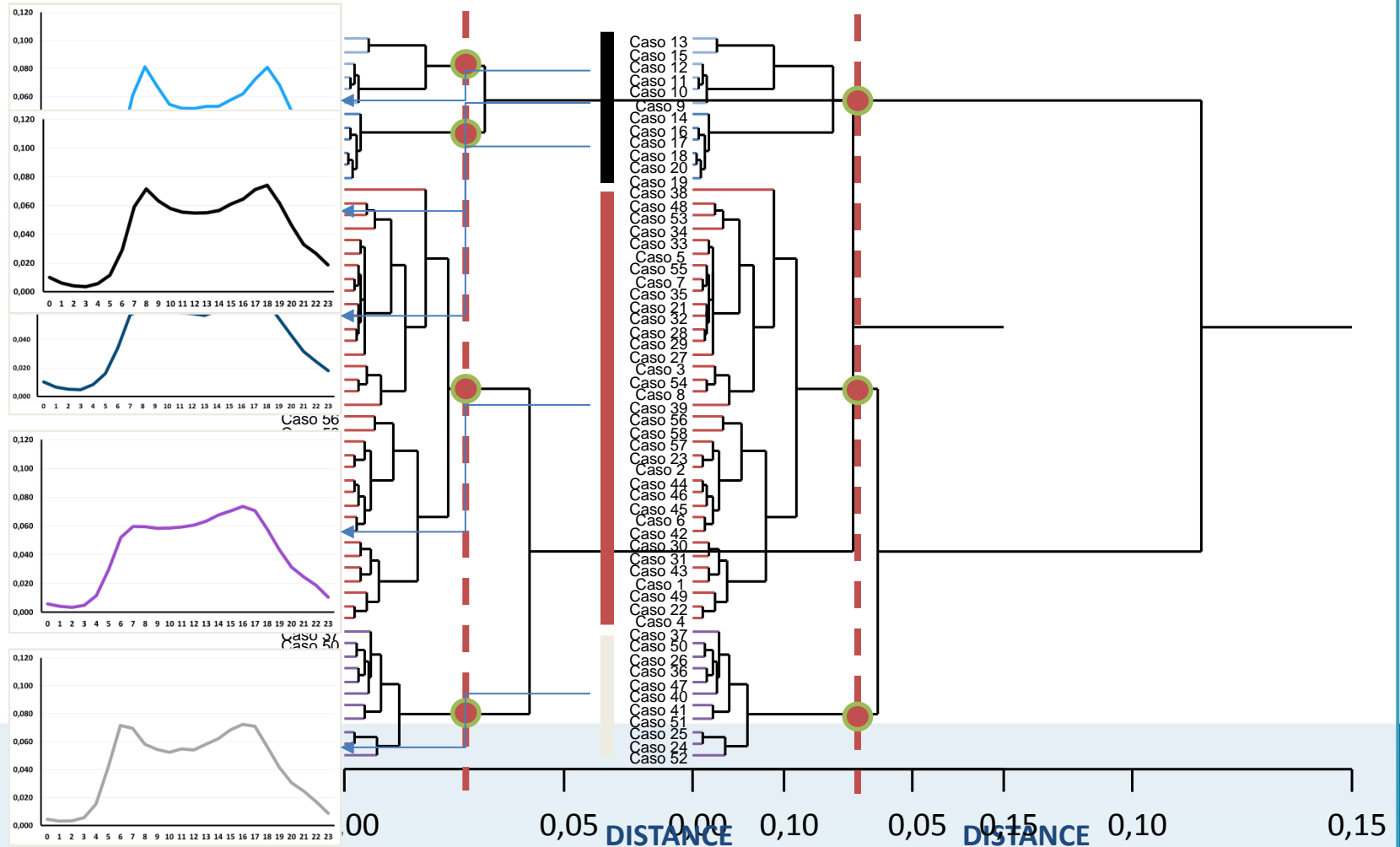



# Typical Days of the Week

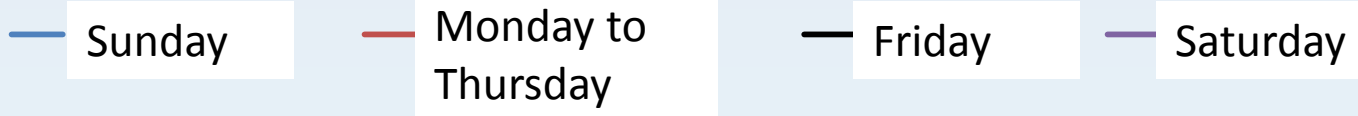
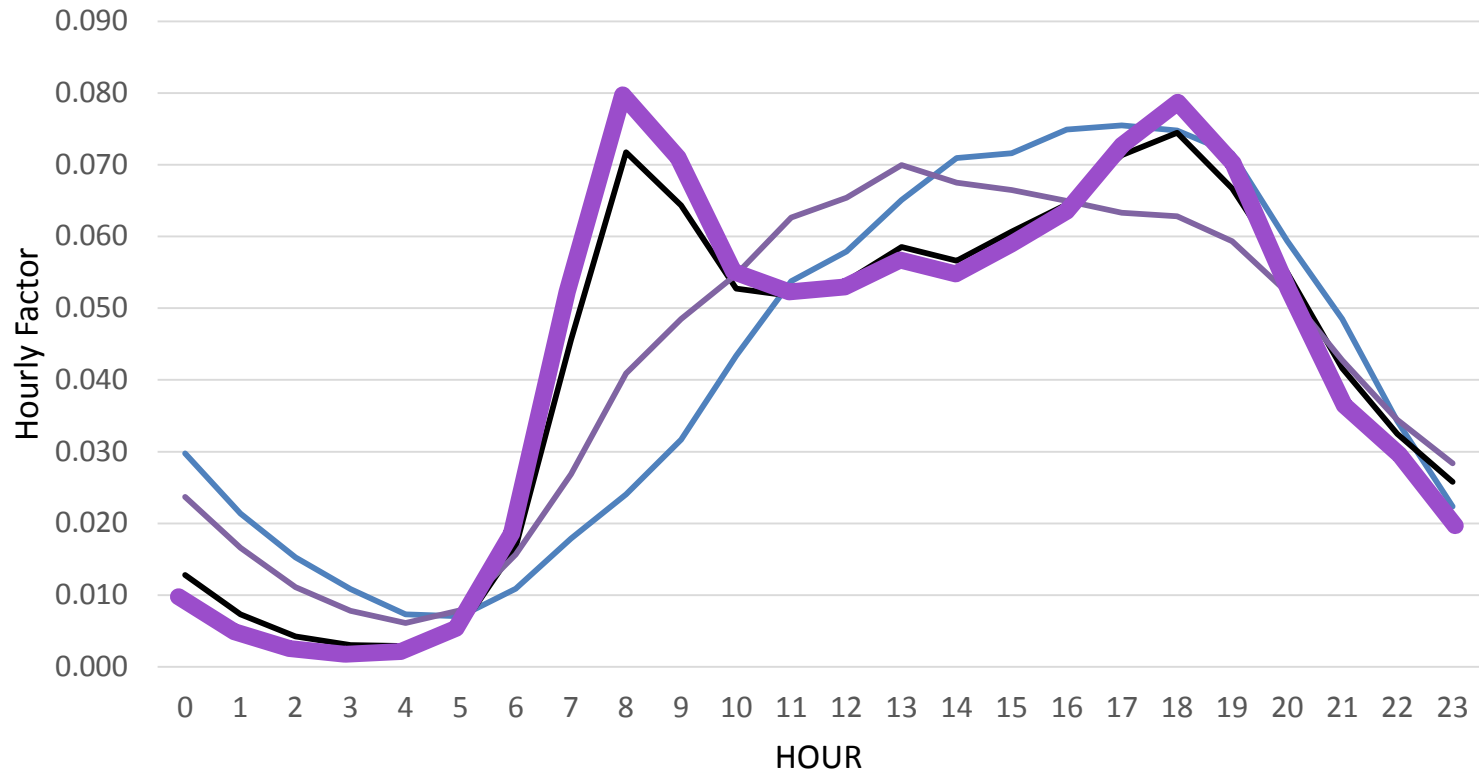

# Typical Days of Week

All Vehicles:

Tuesday to Thursday

Type 1:



Tue to Thu

Type 2:

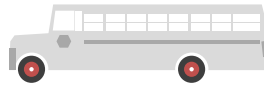

Mon to Fri

Type 3:



Mon to Fri

Type 4:



Mon to Fri

# Atypical Months

All Vehicles:

January, April, December

Type 1:



January, April, December

Type 2 :

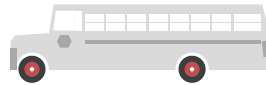

January, April, December

Type 3:



April, December

Type 4 :



January, April, December

# Hour of Day Factors

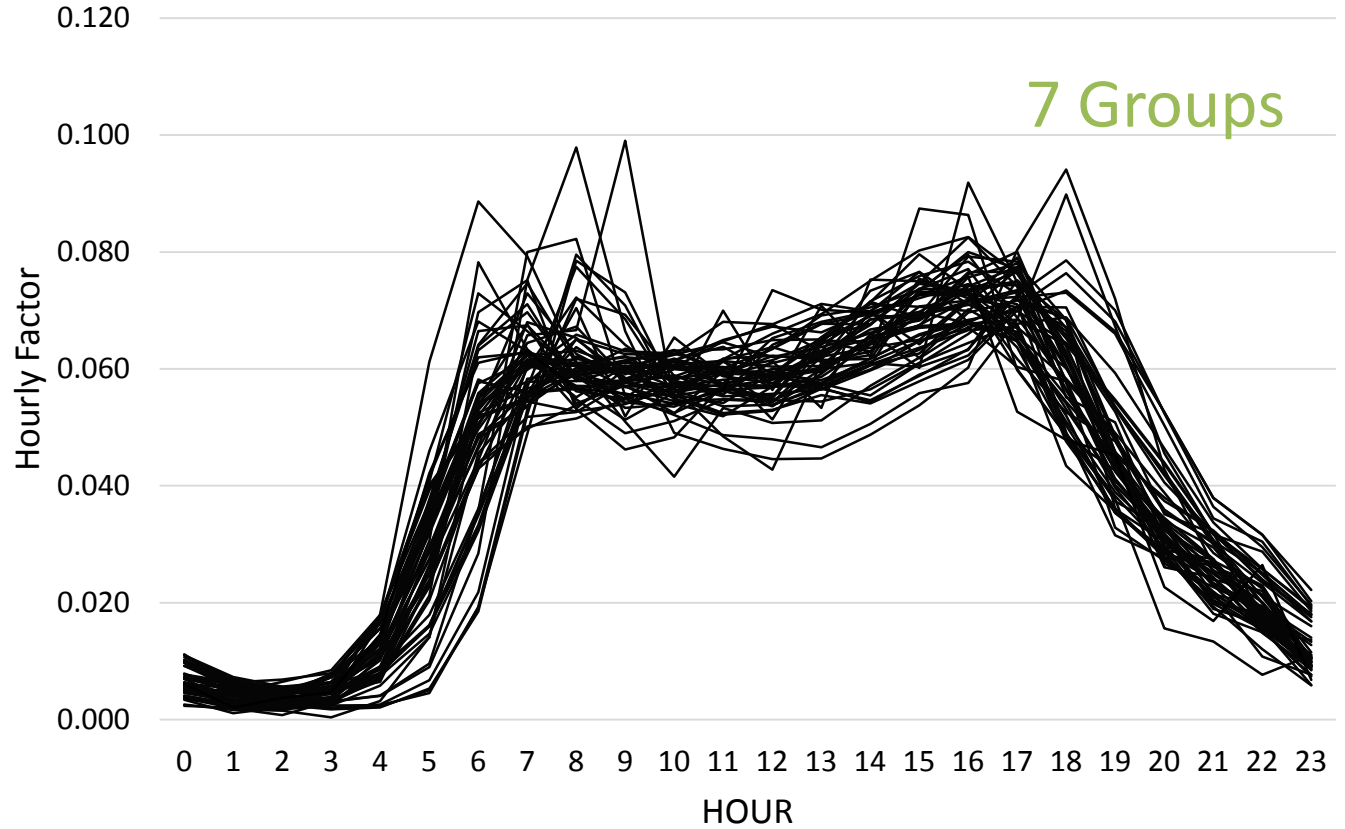
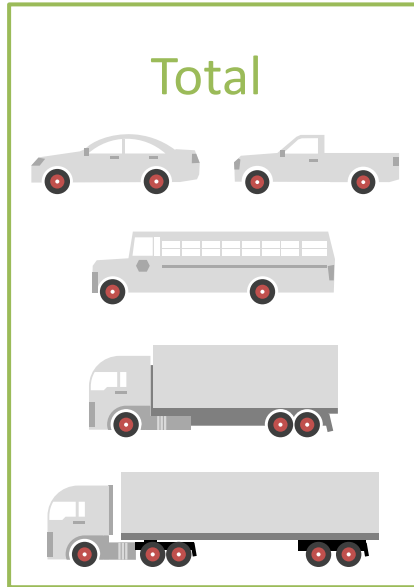

# Hour of Day Factors

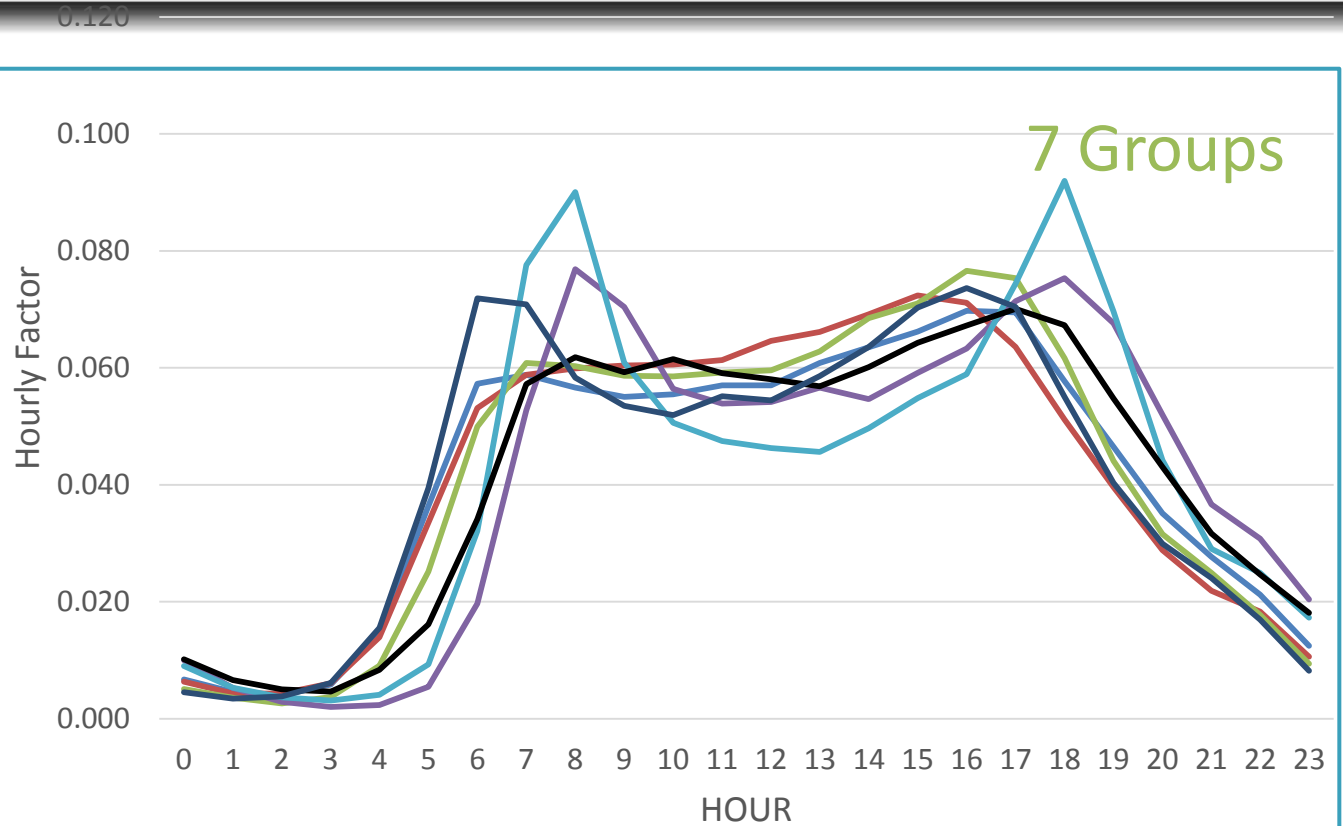
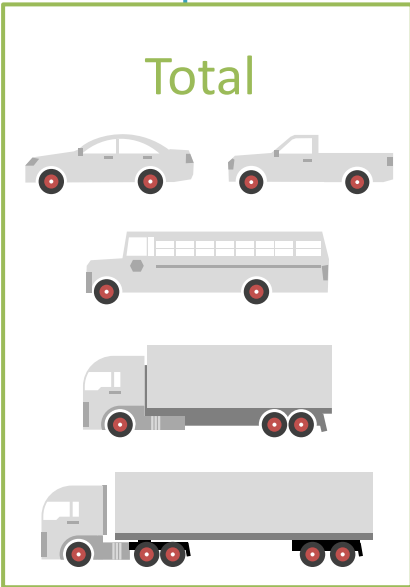

# Hour of Day Factors

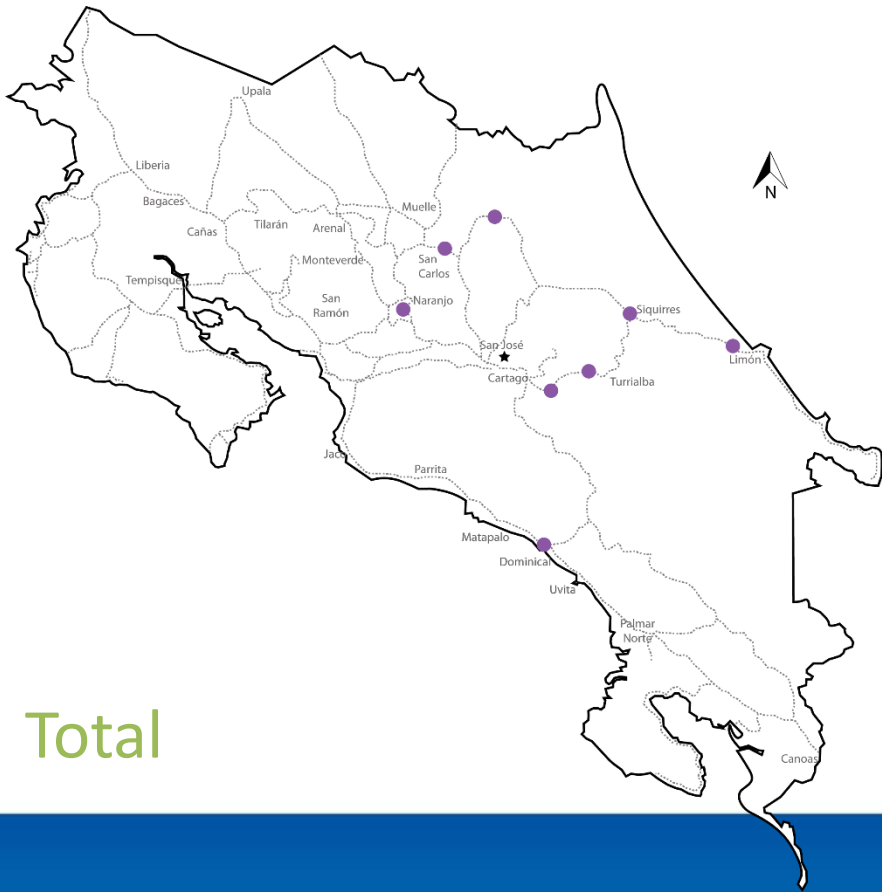

Group 1

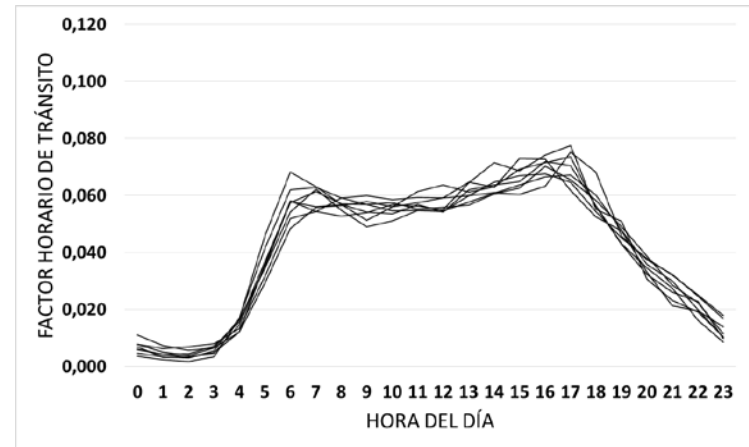

Series

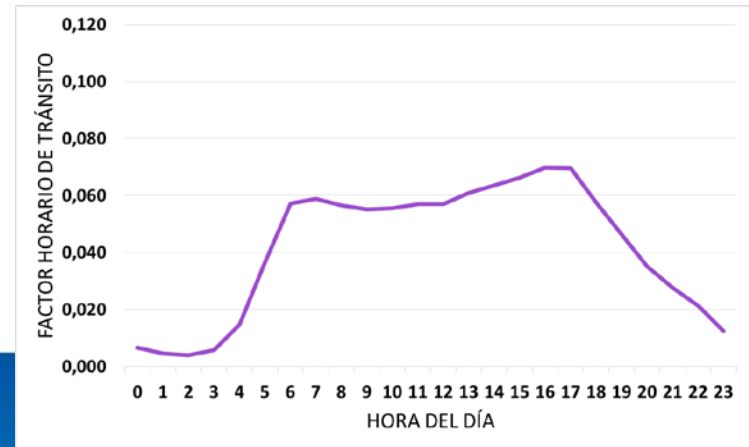

Total HOD TPG 1

# Hour of Day Factors

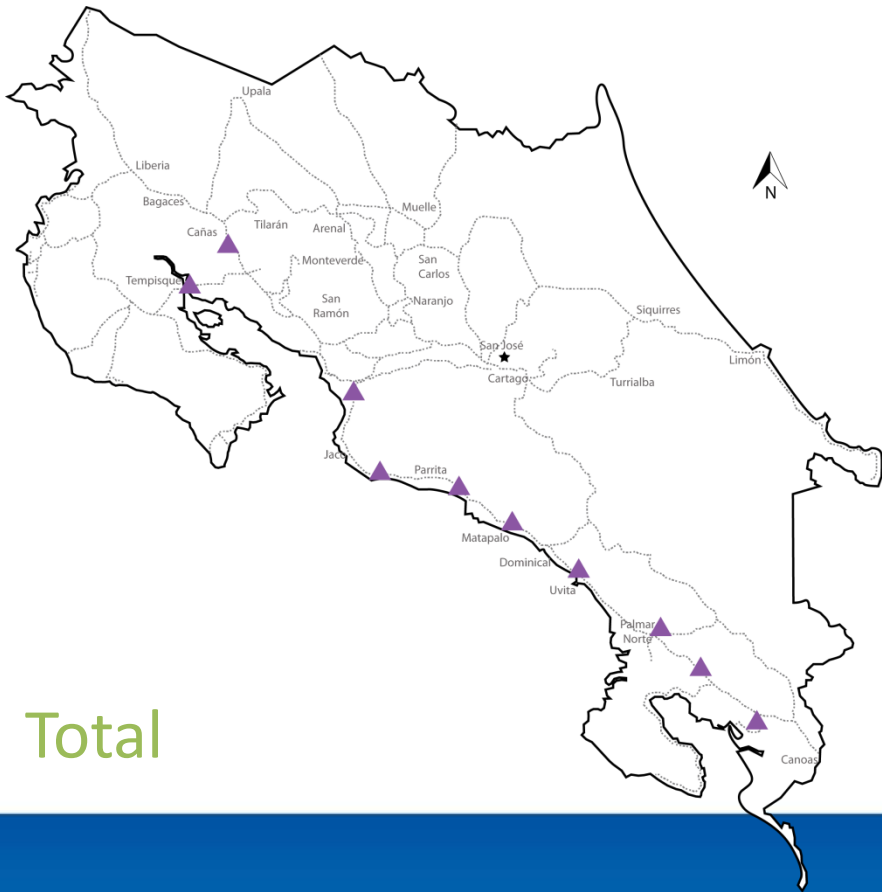

Group 2

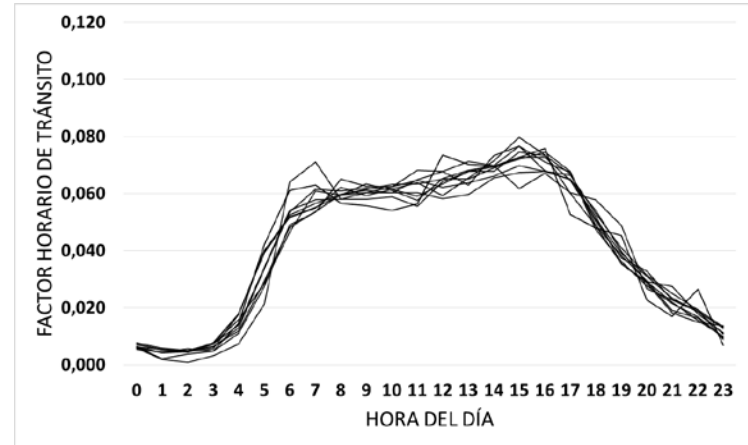

Series

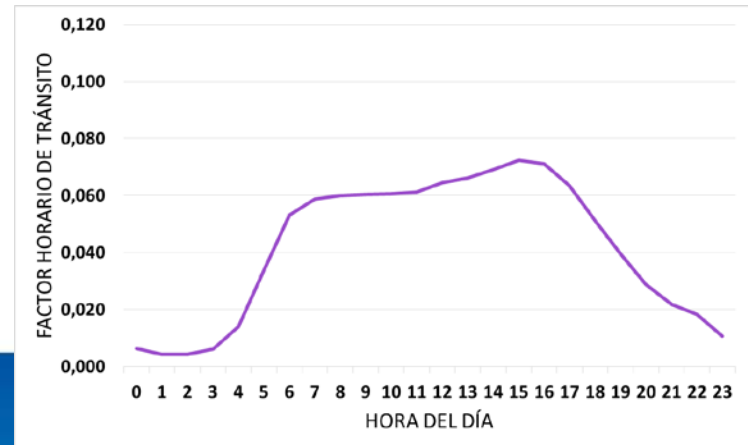

Total HOD TPG 2



# Hour of Day Factors

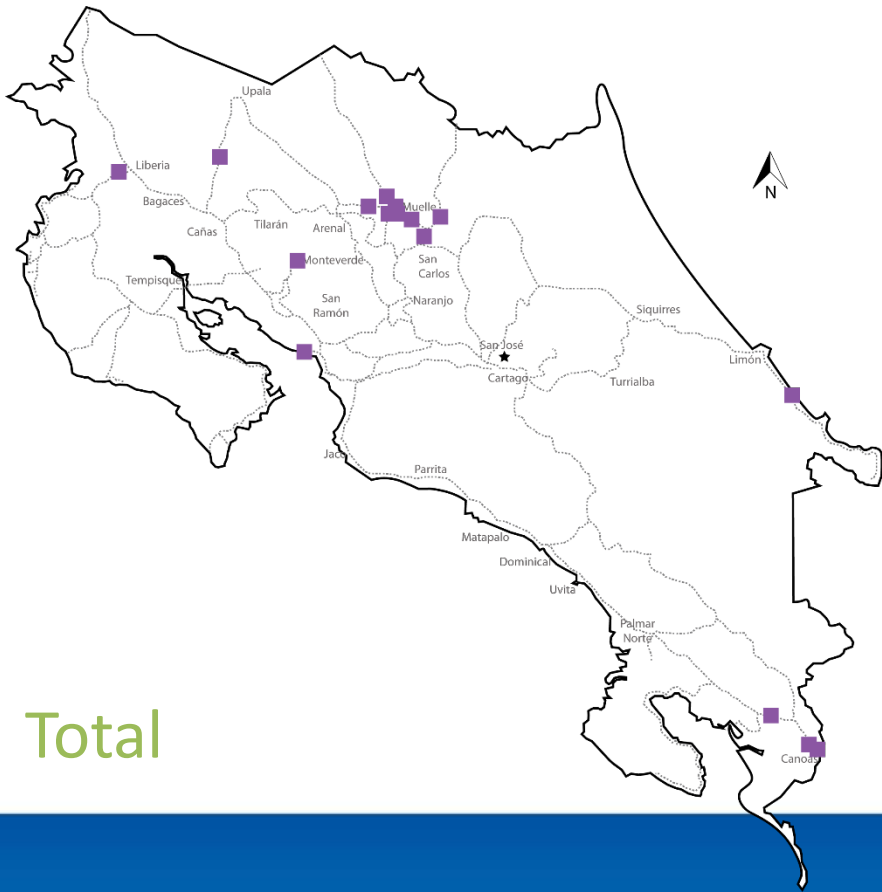

Total

Group 3

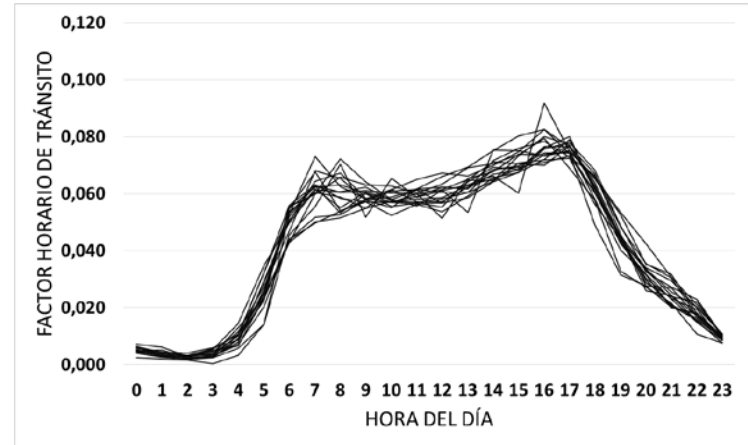

Series

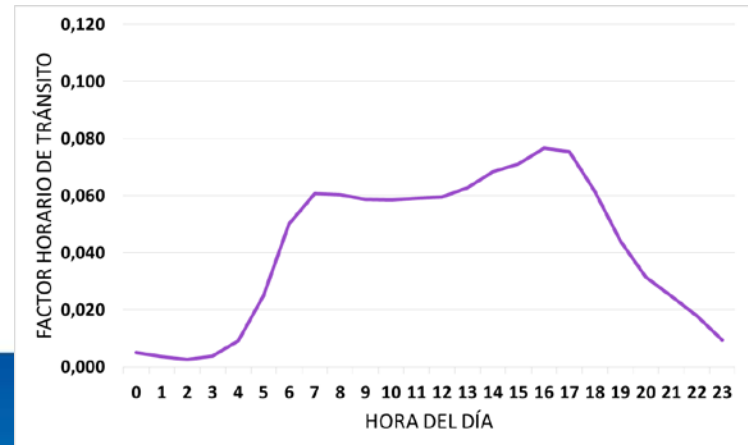

Total HOD TPG 3

# Hour of Day Factors

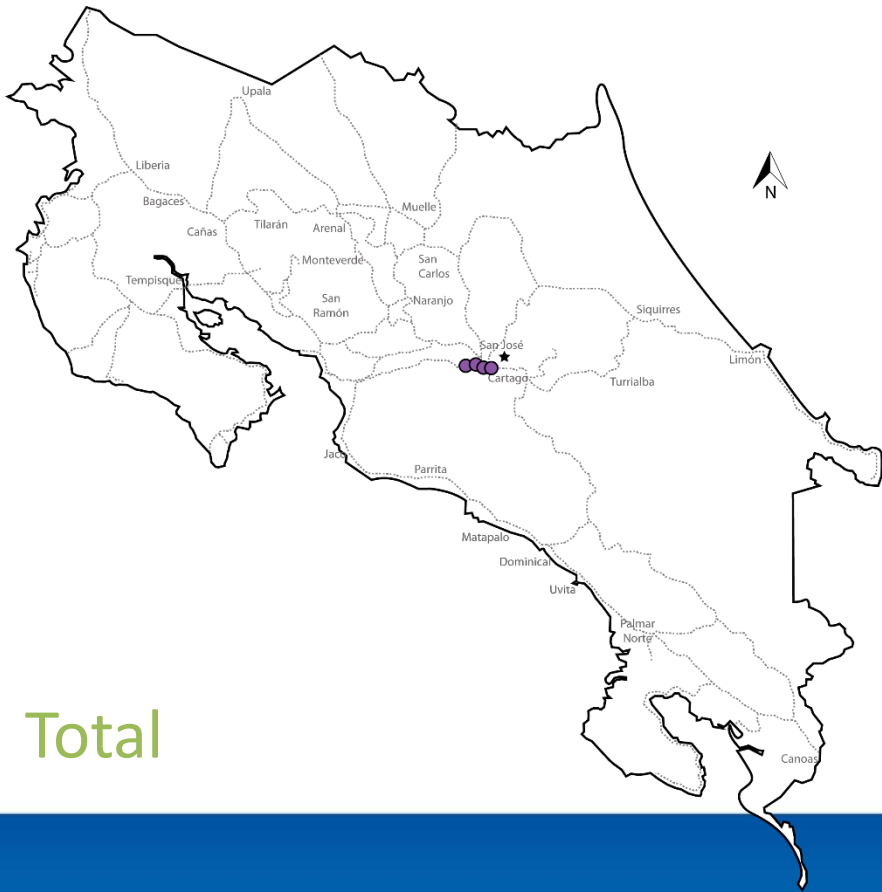

Group 4

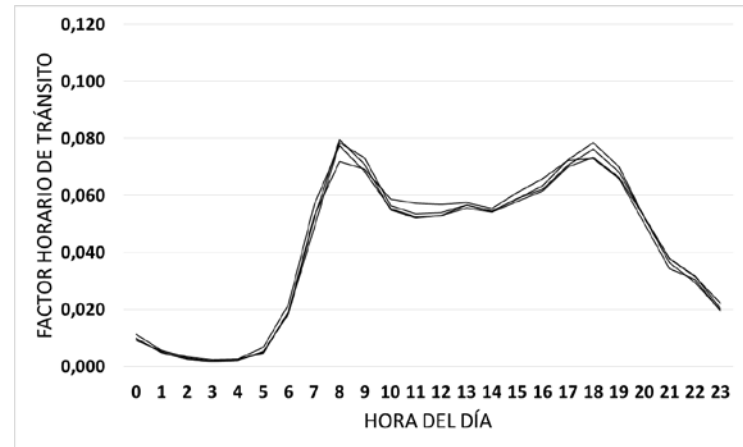

Series

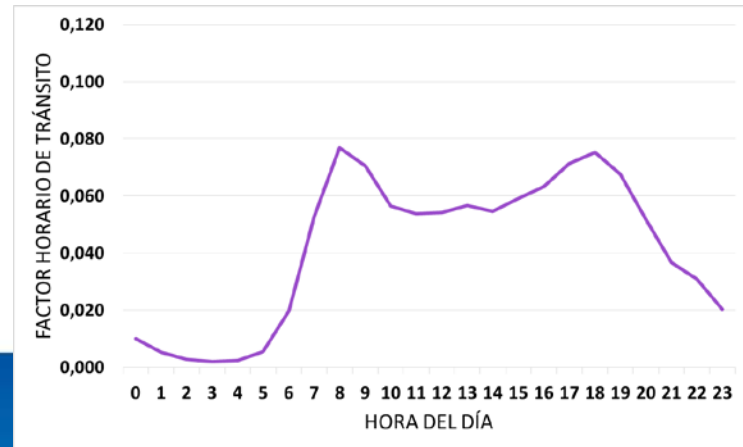

Total HOD TPG 4

# Hour of Day Factors

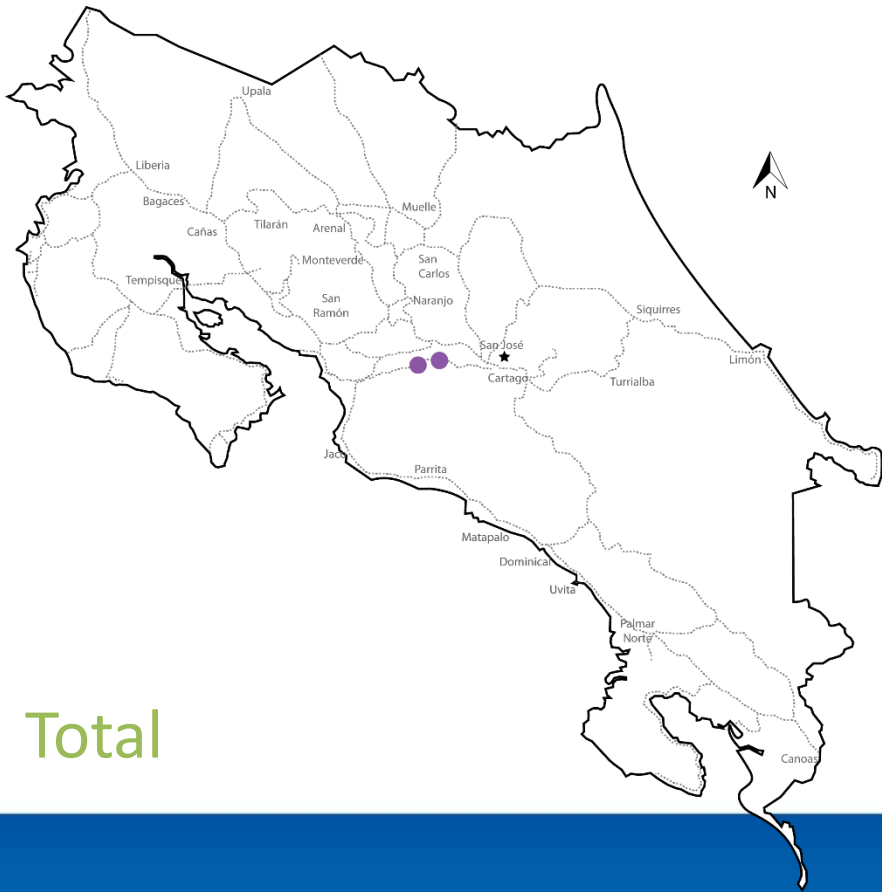

Total

Group 5

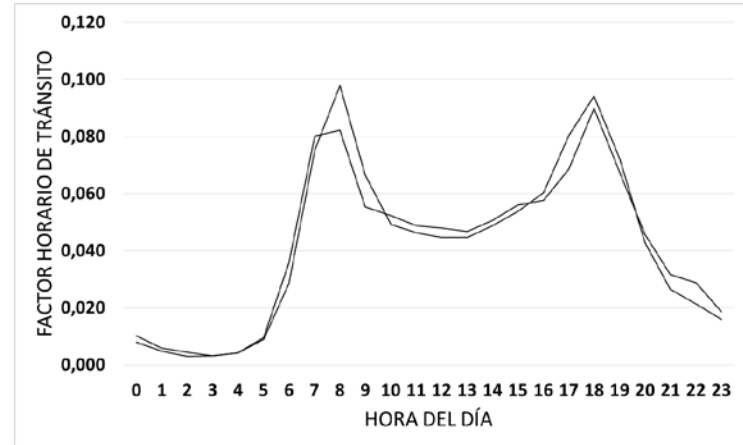

Series

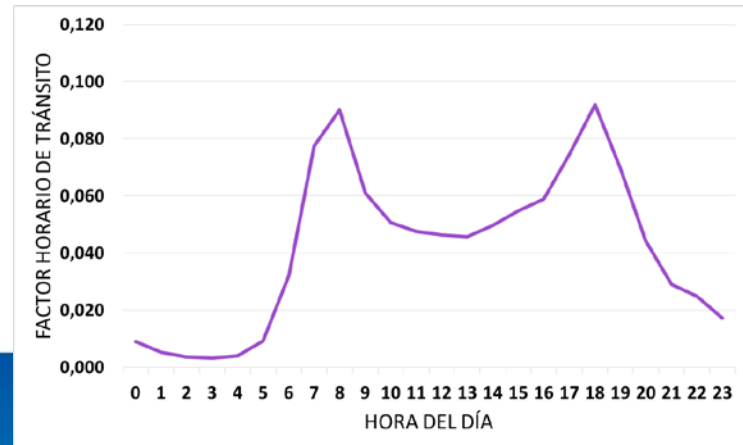

Total HOD TPG 5

# Hour of Day Factors

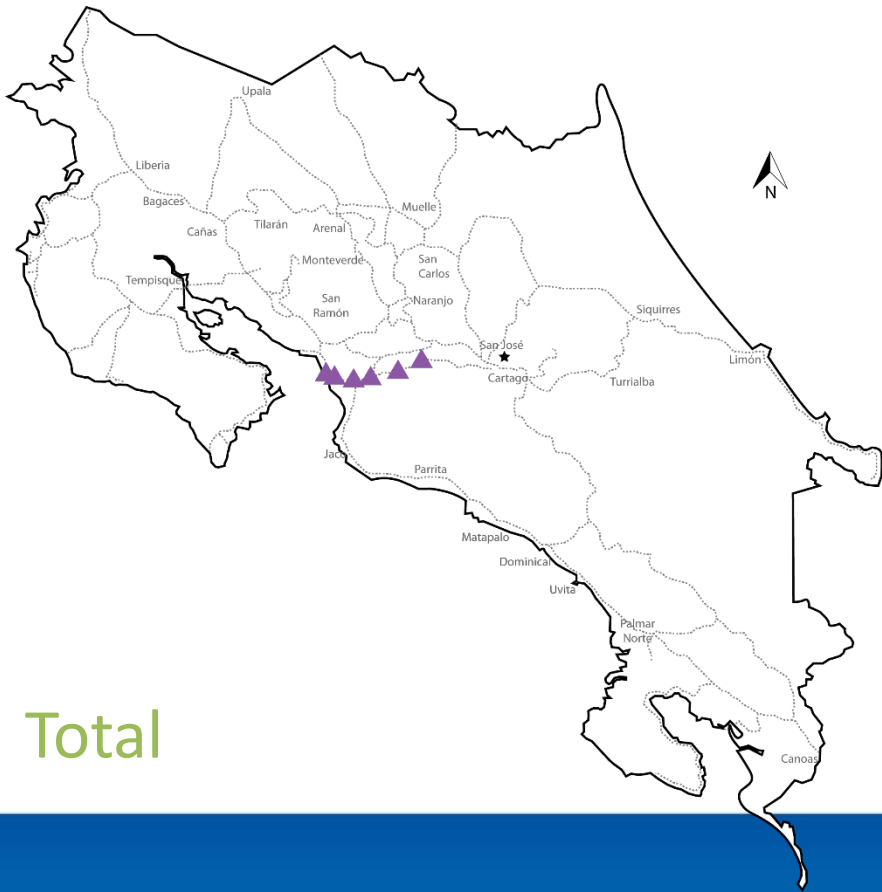

Total

Group 6

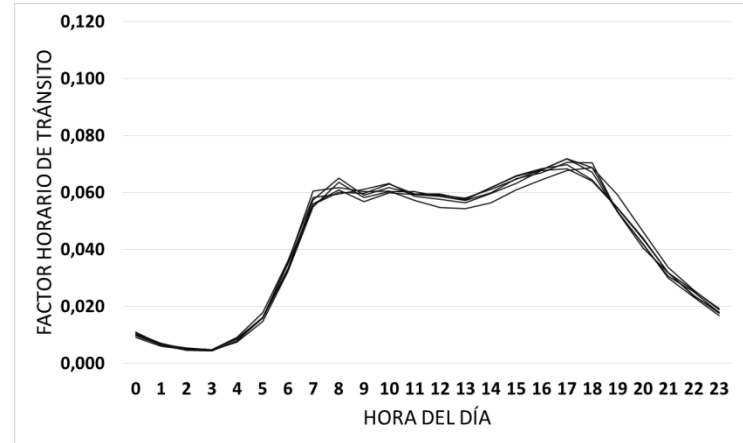

Series

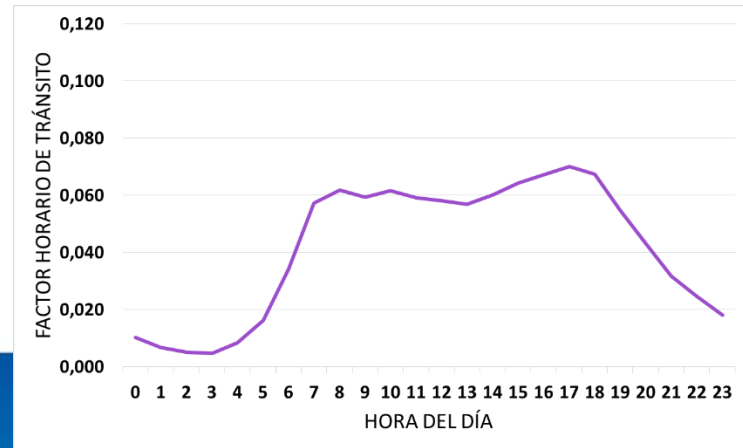

Total HOD TPG 6

# Hour of Day Factors

4 Groups

Type 3

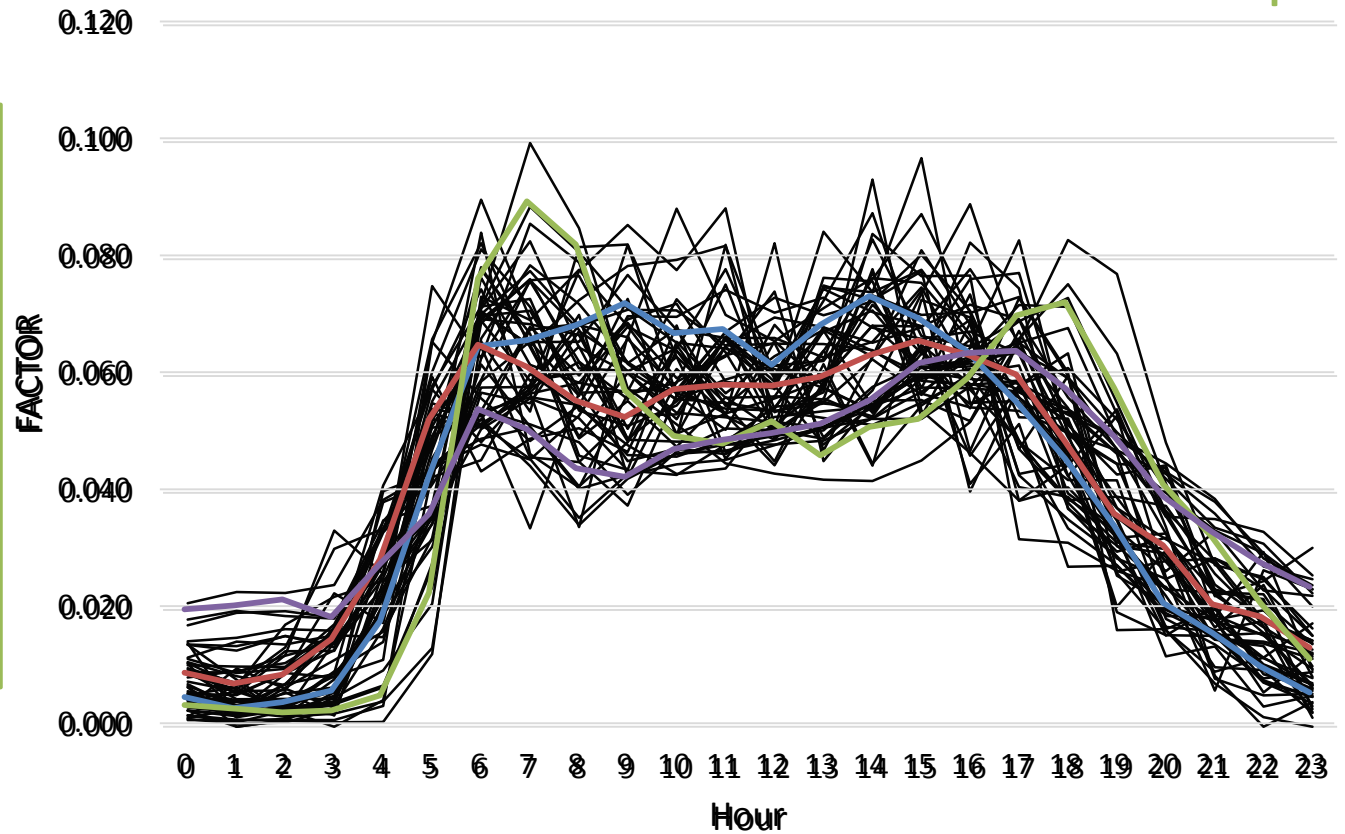

# Hour of Day Factors

7 Groups

Type 4

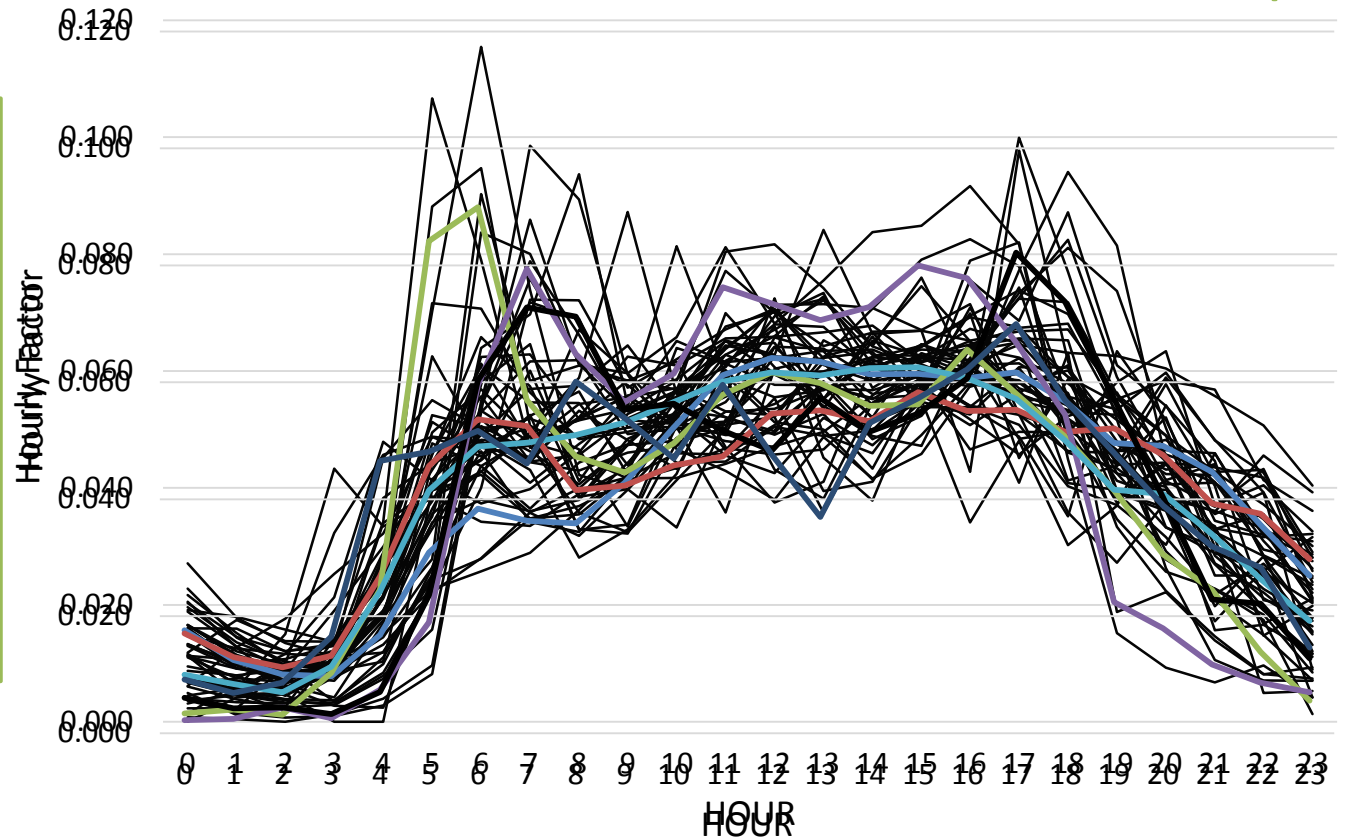

# Hour of Day Factors

5 Groups

Type 4

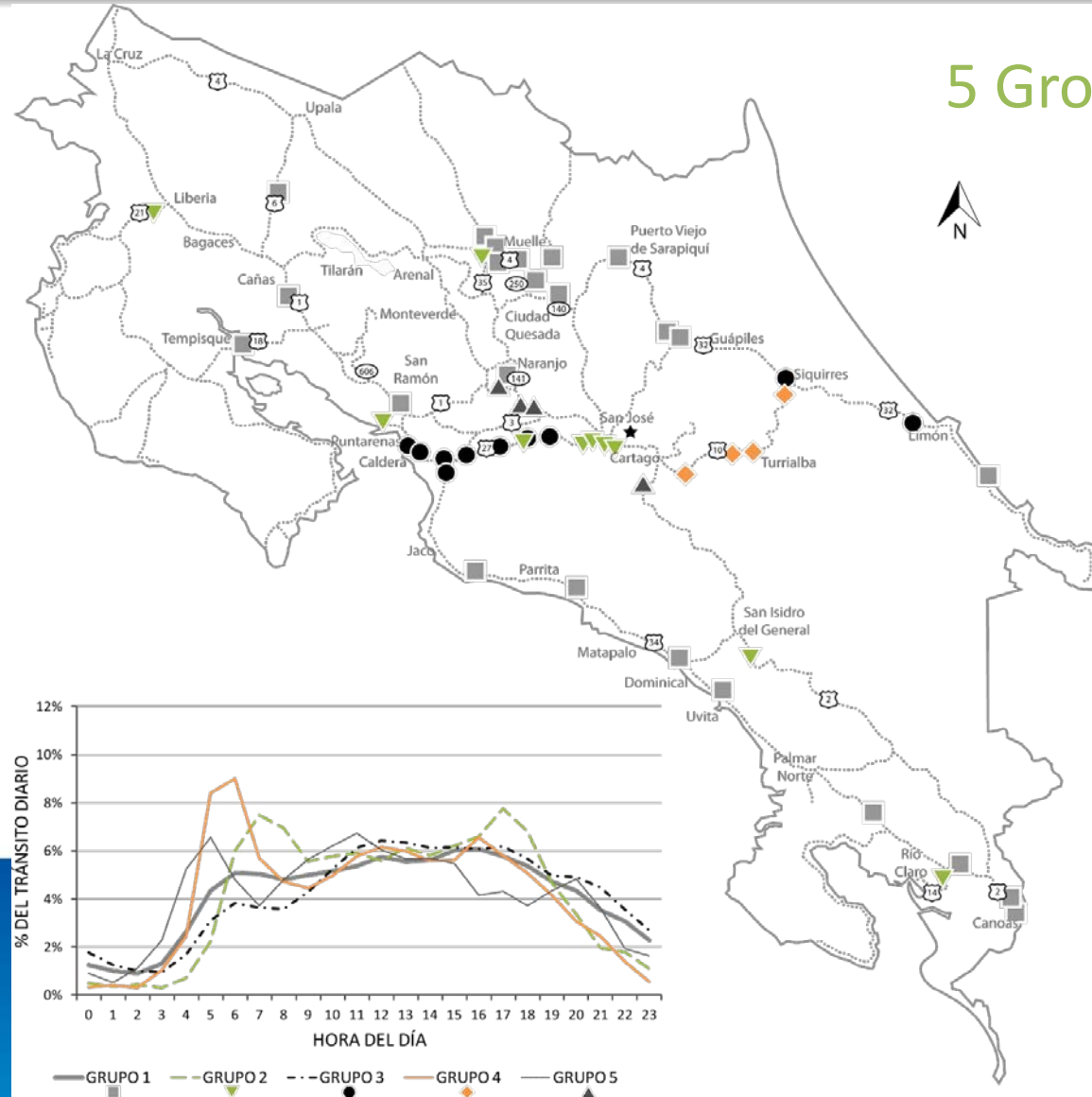



# Day of the Week Factors

4 Groups

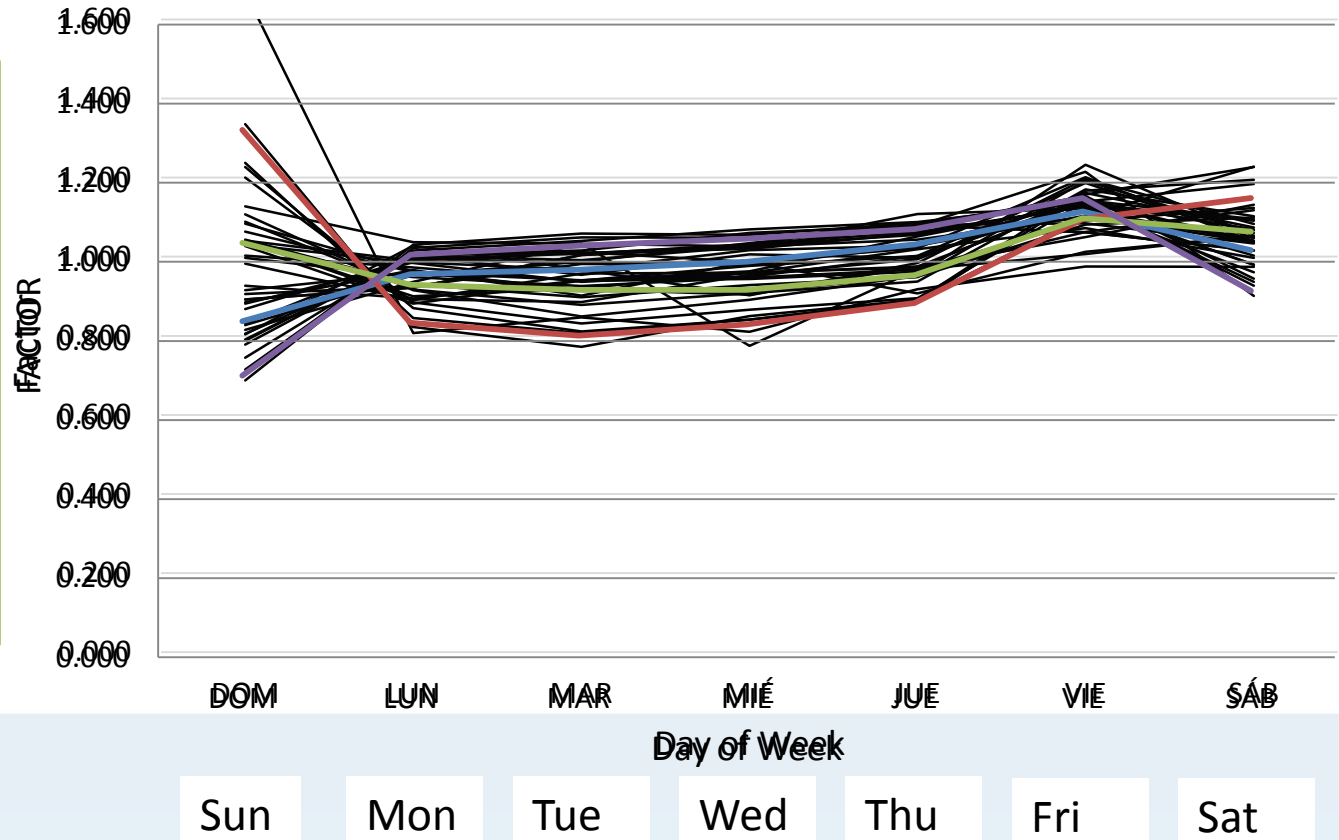
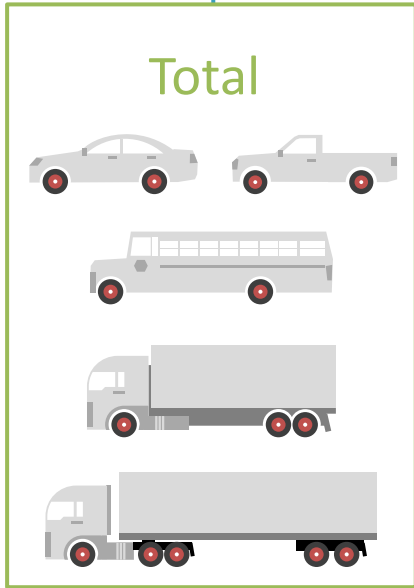

# Day of Week Factors

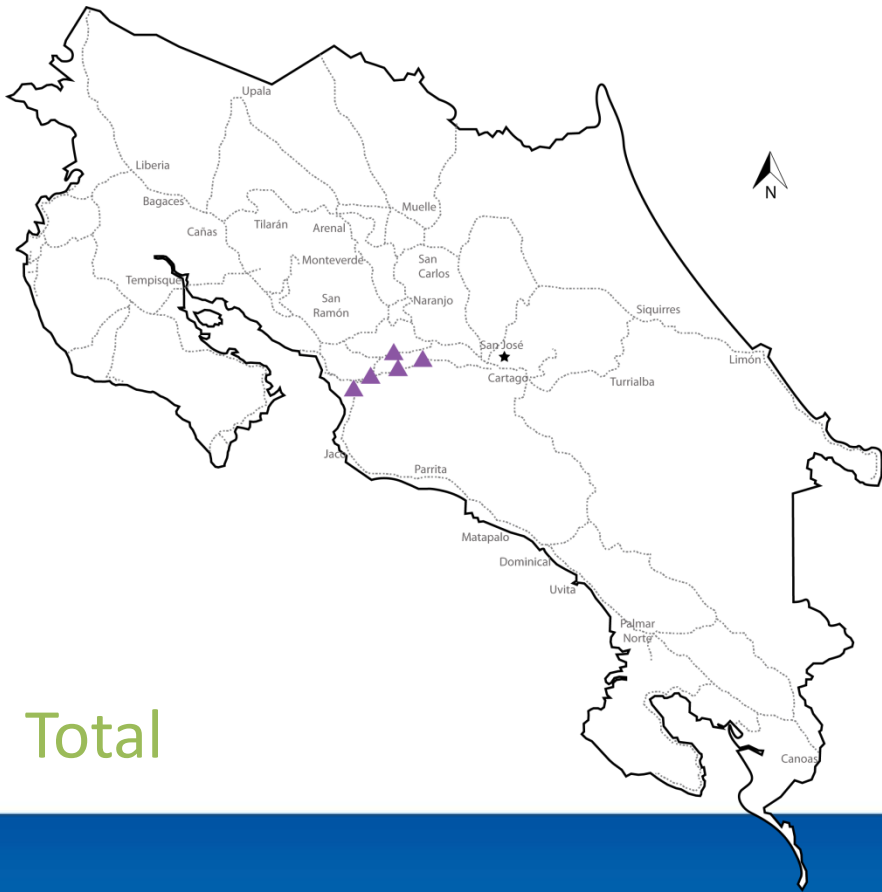

Total

Group 1

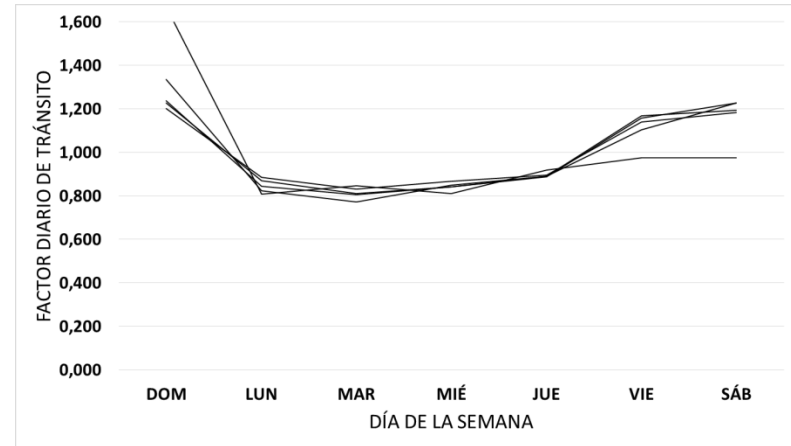

Series

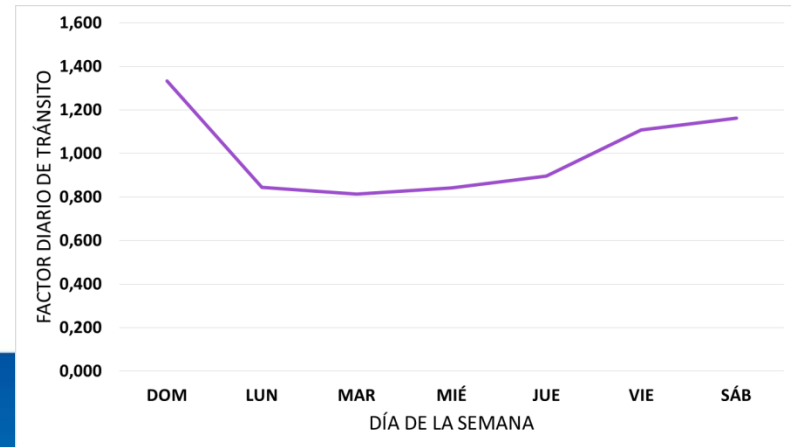

Total DOW TPG 1

# Day of Week Factors

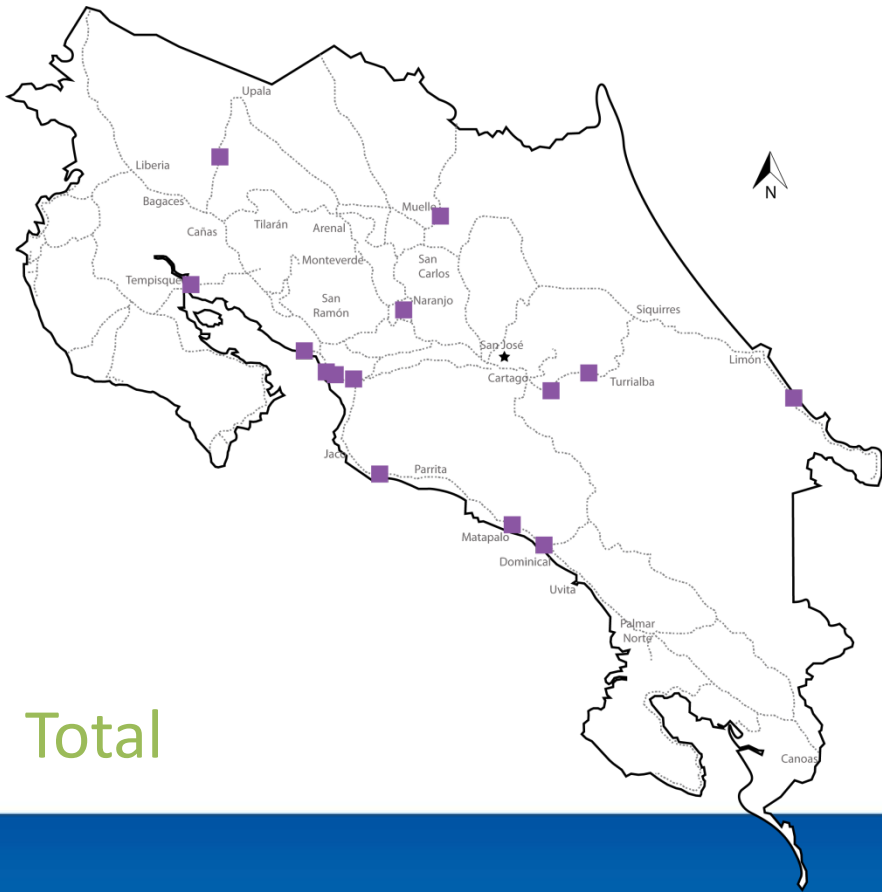

Group 2

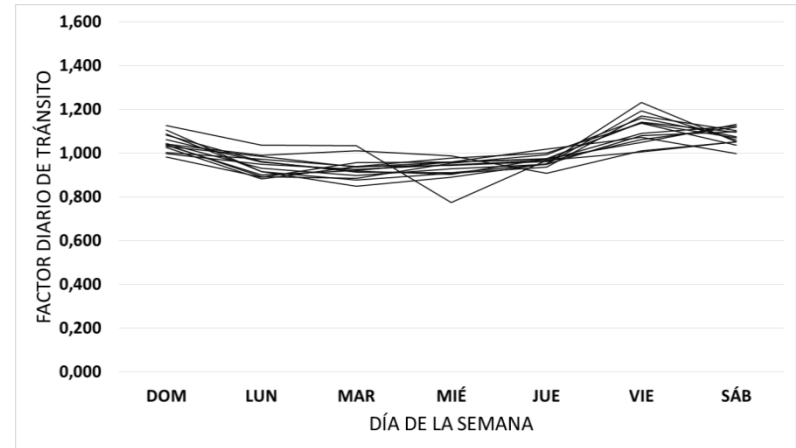

Series

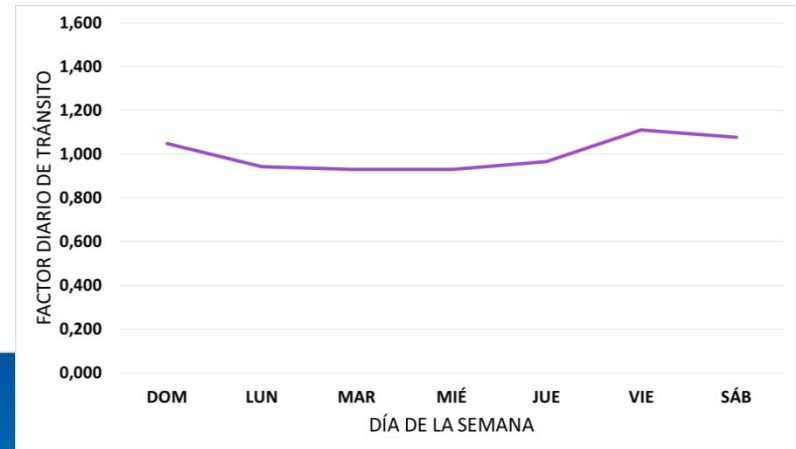

Total DOW TPG 2

# Day of Week Factors

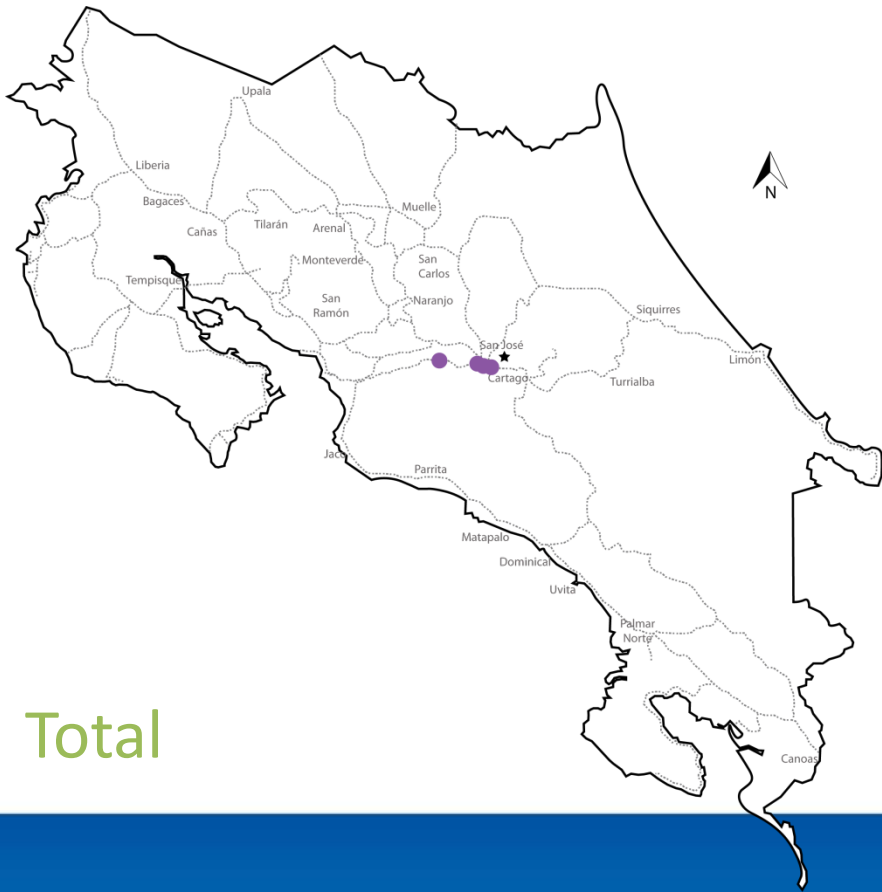

Total

Group 3

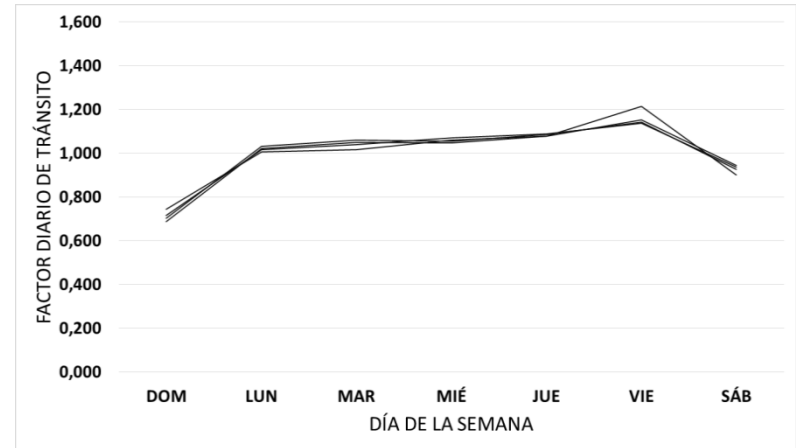

Series

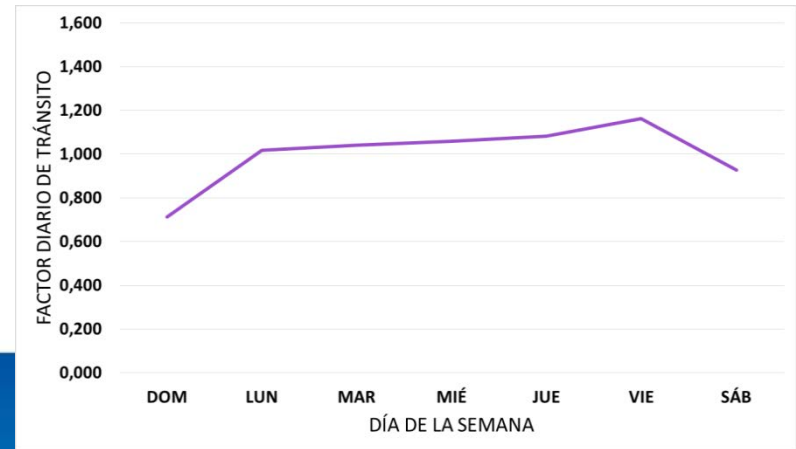

Total DOW TPG 3

# Day of Week Factors

6 Groups

Type 3

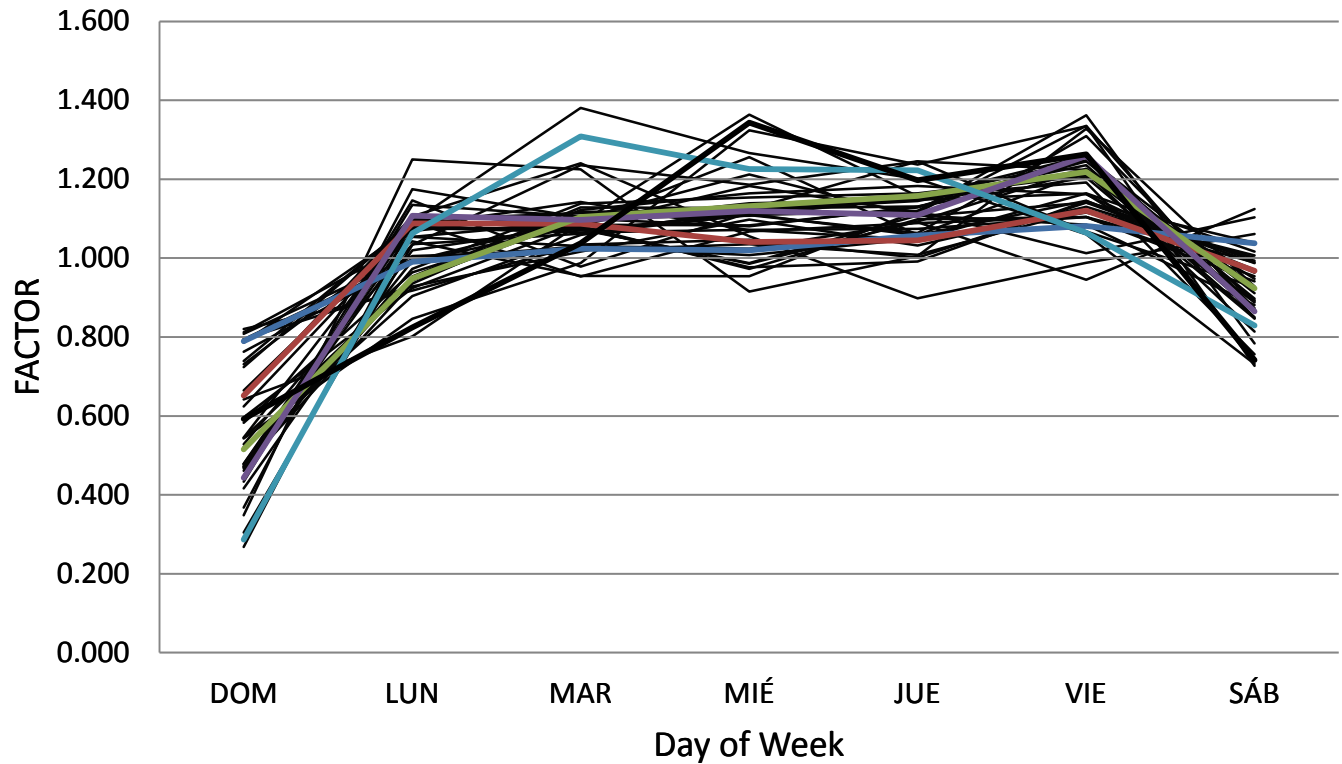

Sun

Mon

Tue

Wed

Thu

Fri

Sab

# Day of Week Factors

4 Groups

Type 4

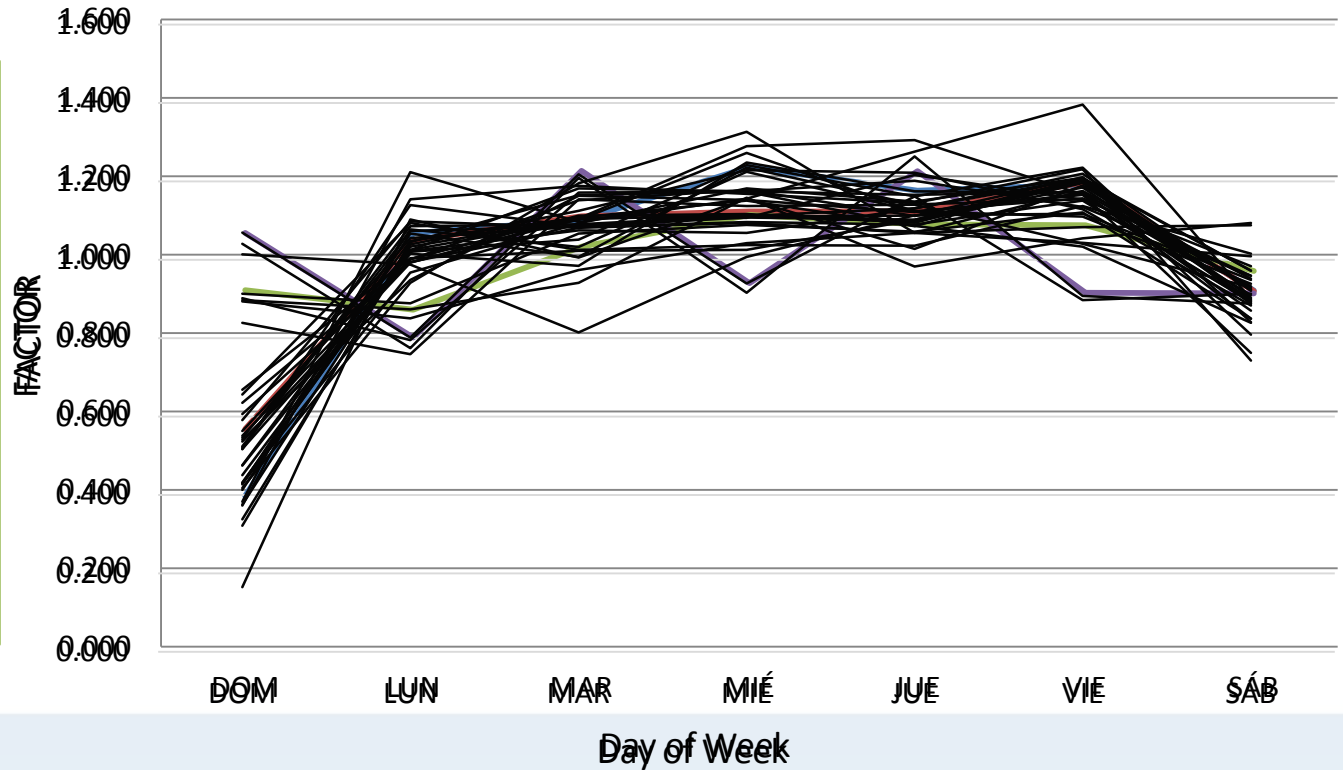

Sun

Mon

Tue

Wed

Thu

Fri

Sab

# Seasonal Factors

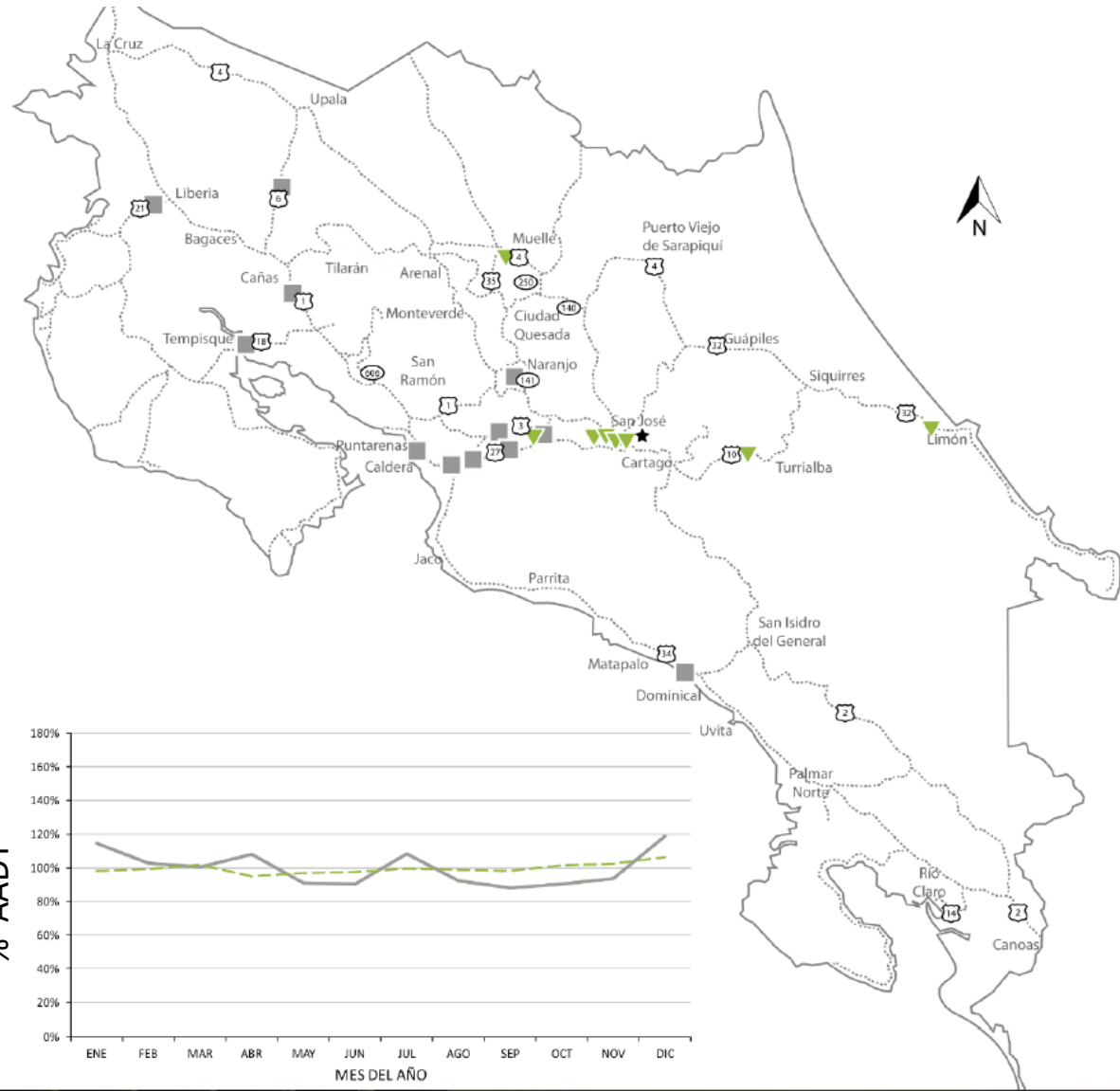
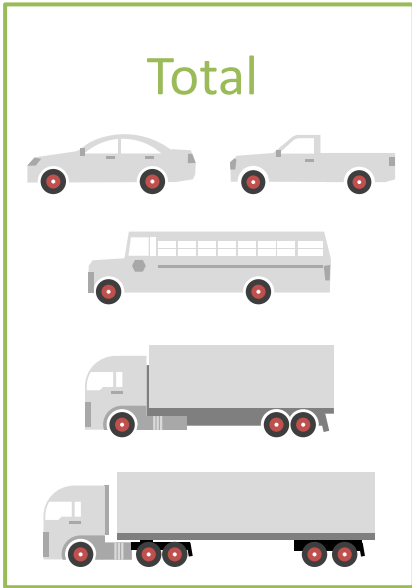



# Seasonal Factors

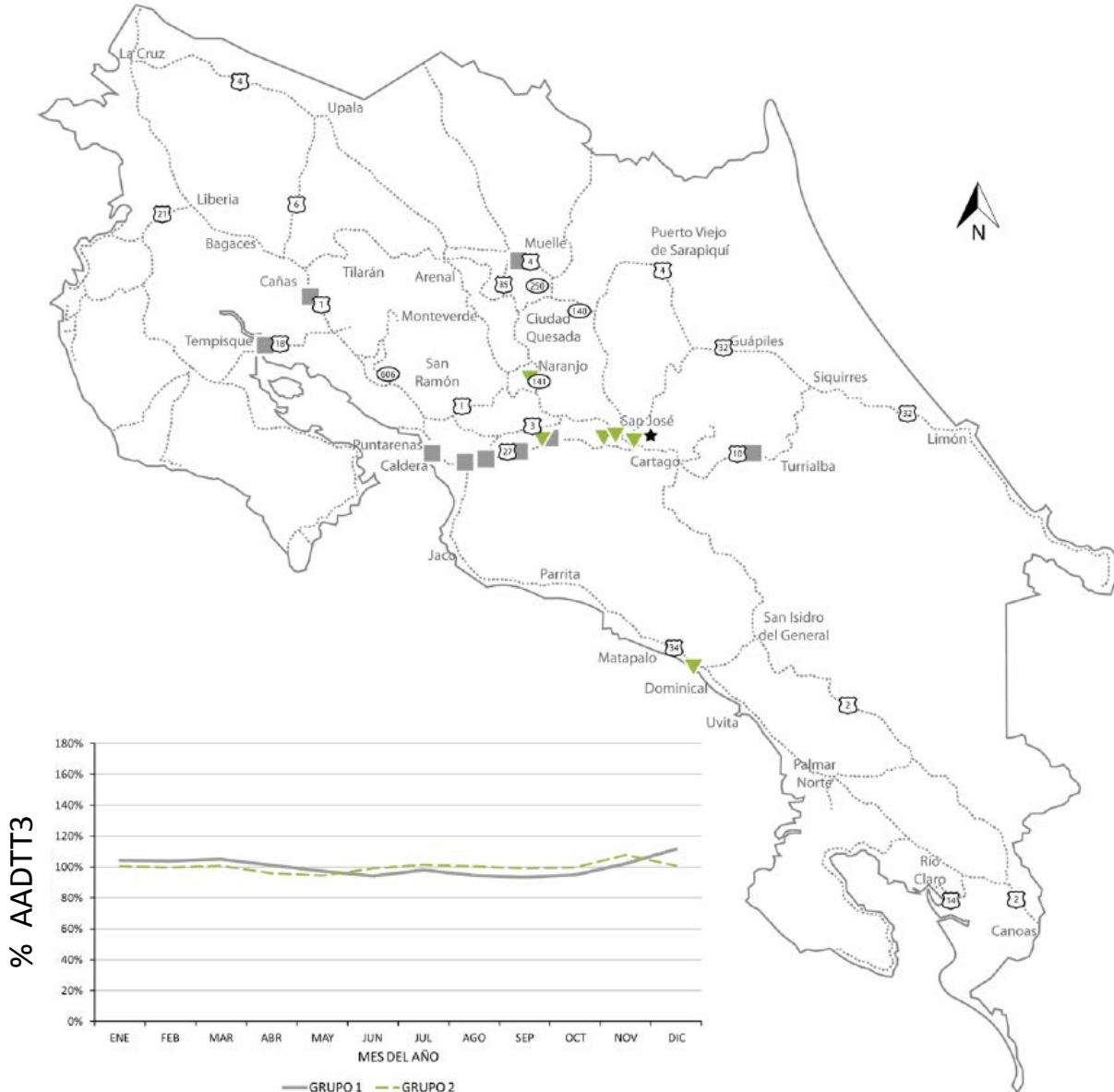
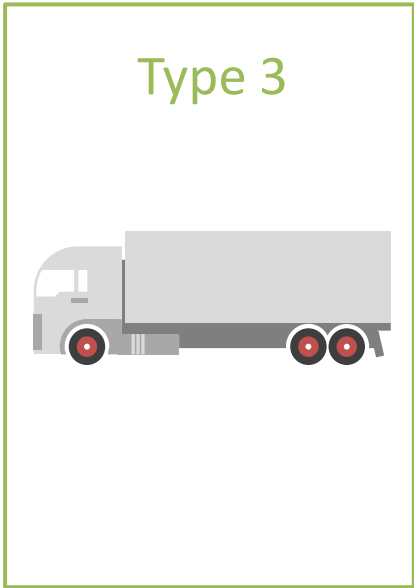

# Seasonal Factors

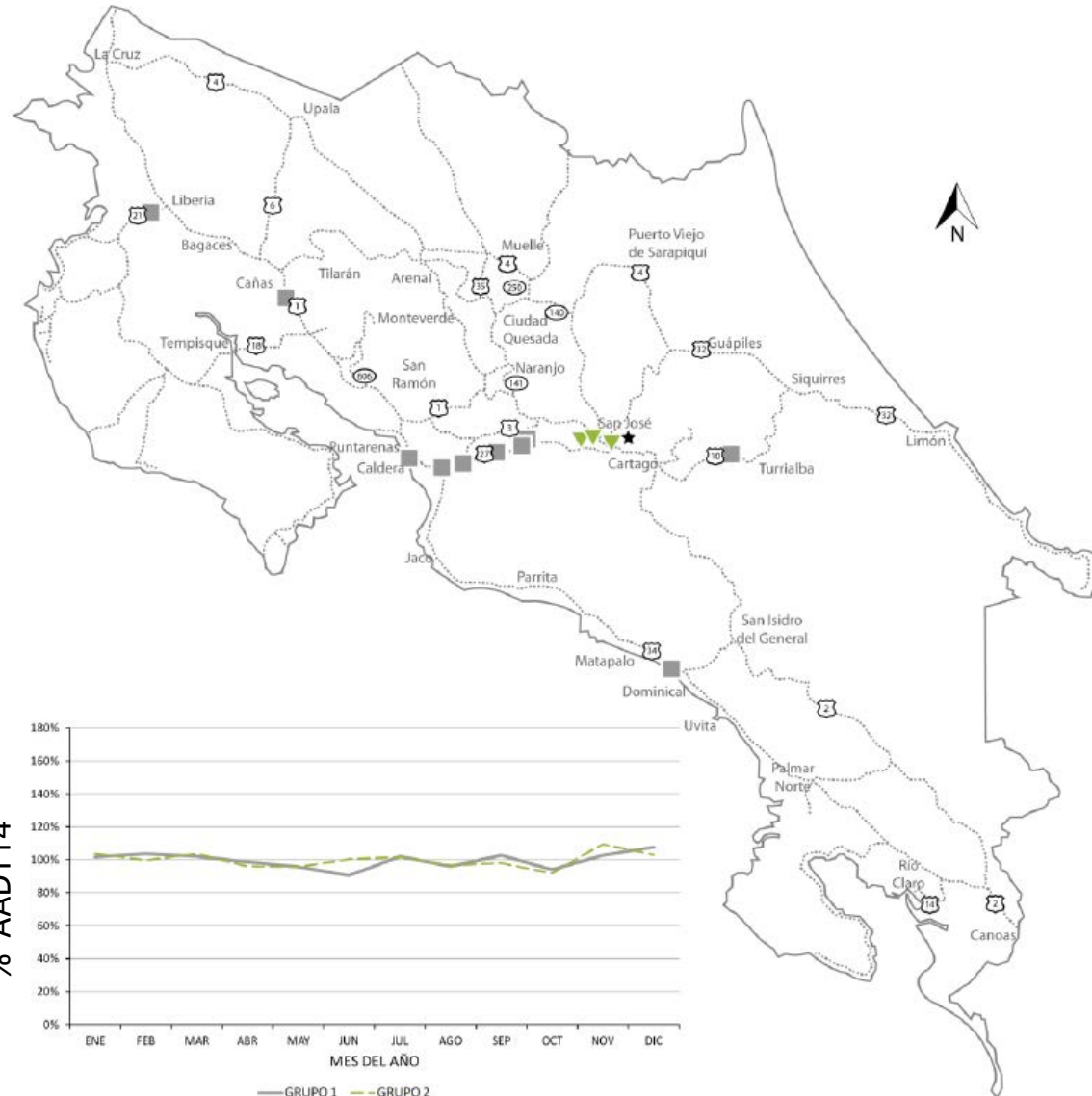
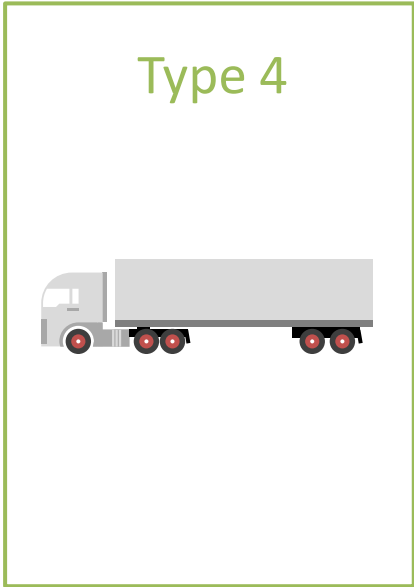

# Final Remarks

- Cluster analysis is an adequate tool to generate **Traffic Pattern Groups** in Costa Rica.
- Temporal variations of traffic in **urban roads and rural roads** present **significant differences**.

# Final Remarks

- Holidays and festivities (for instance Easter Week) significantly affect the temporal traffic variations.
- In Costa Rica, articulated truck traffic hourly variations present a valley between two peaks in urban areas.
- Traffic Pattern Group for recreational (tourism) roads.

# Final Remarks

- Temporal traffic variations of **passenger vehicles and rural trucks** are **different**.
- Greater number of permanent count stations is required.
- More resources towards traffic monitoring.



Accelerated Pavement Testing

International Conference. **September 19-21, 2016**

**Standing Committee on Full-Scale Accelerated  
Pavement Testing (AFD40)**

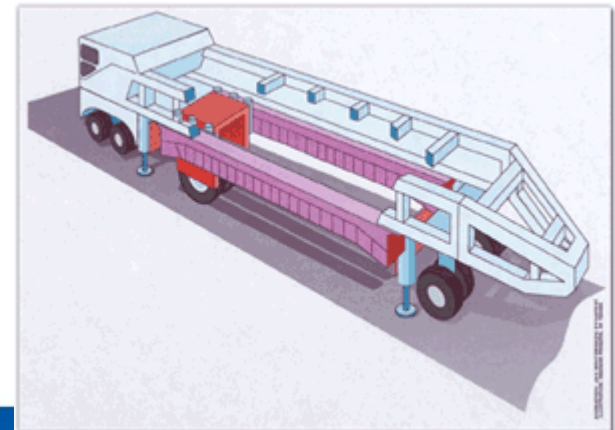

Thank you!