

# NCHRP

## SYNTHESIS 324

NATIONAL  
COOPERATIVE  
HIGHWAY  
RESEARCH  
PROGRAM

### **Prefabricated Bridge Elements and Systems to Limit Traffic Disruption During Construction**

*A Synthesis of Highway Practice*

TRANSPORTATION RESEARCH BOARD  
OF THE NATIONAL ACADEMIES

# **NCHRP**

## **SYNTHESIS 324**

**NATIONAL  
COOPERATIVE  
HIGHWAY  
RESEARCH  
PROGRAM**

---

---

### **Prefabricated Bridge Elements and Systems to Limit Traffic Disruption During Construction**

***A Synthesis of Highway Practice***

**TRANSPORTATION RESEARCH BOARD**  
*OF THE NATIONAL ACADEMIES*

---

---

# **NCHRP**

## **SYNTHESIS 324**

**NATIONAL  
COOPERATIVE  
HIGHWAY  
RESEARCH  
PROGRAM**

---

---

### **Prefabricated Bridge Elements and Systems to Limit Traffic Disruption During Construction**

***A Synthesis of Highway Practice***

**TRANSPORTATION RESEARCH BOARD**  
*OF THE NATIONAL ACADEMIES*

---

---

## TRANSPORTATION RESEARCH BOARD EXECUTIVE COMMITTEE 2003 (Membership as of October 2003)

### Officers

**Chair:** GENEVIEVE GIULIANO, *Director and Professor, School of Policy, Planning, and Development, University of Southern California, Los Angeles*

**Vice Chairman:** MICHAEL S. TOWNES, *President and CEO, Hampton Roads Transit, Hampton, VA*

**Executive Director:** ROBERT E. SKINNER, JR., *Transportation Research Board*

### Members

MICHAEL W. BEHRENS, *Executive Director, Texas DOT*  
JOSEPH H. BOARDMAN, *Commissioner, New York State DOT*  
SARAH C. CAMPBELL, *President, TransManagement, Inc., Washington, DC*  
E. DEAN CARLSON, *President, Carlson Associates, Topeka, KS*  
JOANNE F. CASEY, *President and CEO, Intermodal Association of North America, Greenbelt, MD*  
JAMES C. CODELL III, *Secretary, Kentucky Transportation Cabinet*  
JOHN L. CRAIG, *Director, Nebraska Department of Roads*  
BERNARD S. GROSECLOSE, JR., *President and CEO, South Carolina State Ports Authority*  
SUSAN HANSON, *Landry University Professor of Geography, Clark University*  
LESTER A. HOEL, *L.A. Lacy Distinguished Professor of Engineering, Department of Civil Engineering, University of Virginia*  
HENRY L. HUNGERBEELE, *Director, Missouri DOT*  
ADIB K. KANAFANI, *Cahill Professor and Chairman, Department of Civil and Environmental Engineering, University of California at Berkeley*  
RONALD F. KIRBY, *Director of Transportation Planning, Metropolitan Washington Council of Governments*  
HERBERT S. LEVINSON, *Principal, Herbert S. Levinson Transportation Consultant, New Haven, CT*  
MICHAEL D. MEYER, *Professor, School of Civil and Environmental Engineering, Georgia Institute of Technology*  
JEFF P. MORALES, *Director of Transportation, California DOT*  
KAM MOVASSAGHI, *Secretary of Transportation, Louisiana Department of Transportation and Development*  
CAROL A. MURRAY, *Commissioner, New Hampshire DOT*  
DAVID PLAVIN, *President, Airports Council International, Washington, DC*  
JOHN REBENS DORF, *Vice President, Network and Service Planning, Union Pacific Railroad Company, Omaha, NE*  
CATHERINE L. ROSS, *Harry West Chair of Quality Growth and Regional Development, College of Architecture, Georgia Institute of Technology*  
JOHN M. SAMUELS, *Senior Vice President, Operations, Planning, and Support, Norfolk Southern Corporation, Norfolk, VA*  
PAUL P. SKOUTELAS, *CEO, Port Authority of Allegheny County, Pittsburgh, PA*  
MARTIN WACHS, *Director, Institute of Transportation Studies, University of California at Berkeley*  
MICHAEL W. WICKHAM, *Chairman, Roadway Corporation, Akron, OH*

MARION C. BLAKEY, *Federal Aviation Administration, U.S. DOT (ex officio)*  
SAMUEL G. BONASSO, *Acting Administrator, Research and Special Programs Administration, U.S. DOT (ex officio)*  
REBECCA M. BREWSTER, *President and COO, American Transportation Research Institute, Smyrna, GA (ex officio)*  
GEORGE BUGLIARELLO, *Foreign Secretary, National Academy of Engineering (ex officio)*  
THOMAS H. COLLINS, (Adm., U.S. Coast Guard) *Commandant, U.S. Coast Guard (ex officio)*  
JENNIFER L. DORN, *Federal Transit Administrator, U.S. DOT (ex officio)*  
ROBERT B. FLOWERS (Lt. Gen., U.S. Army), *Chief of Engineers and Commander, U.S. Army Corps of Engineers (ex officio)*  
EDWARD R. HAMBERGER, *President and CEO, Association of American Railroads (ex officio)*  
JOHN C. HORSLEY, *Executive Director, American Association of State Highway and Transportation Officials (ex officio)*  
ROGER L. KING, *Chief Applications Technologist, National Aeronautics and Space Administration (ex officio)*  
ROBERT S. KIRK, *Director, Office of Advanced Automotive Technologies, U.S. Department of Energy (ex officio)*  
RICK KOWALEWSKI, *Acting Director, Bureau of Transportation Statistics, U.S. DOT (ex officio)*  
WILLIAM W. MILLAR, *President, American Public Transit Association (ex officio)*  
MARY E. PETERS, *Federal Highway Administrator, U.S. DOT (ex officio)*  
SUZANNE RUDZINSKI, *Director, Transportation and Regional Programs, U.S. Environmental Protection Agency (ex officio)*  
JEFFREY W. RUNGE, *National Highway Traffic Safety Administrator, U.S. DOT (ex officio)*  
ALLAN RUTTER, *Federal Railroad Administrator, U.S. DOT (ex officio)*  
ANNETTE M. SANDBERG, *Federal Motor Carrier Safety Administrator, U.S. DOT (ex officio)*  
WILLIAM G. SCHUBERT, *Maritime Administrator, U.S. DOT (ex officio)*

### NATIONAL COOPERATIVE HIGHWAY RESEARCH PROGRAM

*Transportation Research Board Executive Committee Subcommittee for NCHRP*

GENEVIEVE GIULIANO, *University of Southern California, Los Angeles*  
(Chair)  
E. DEAN CARLSON, *Carlson Associates, Topeka, KS*  
LESTER A. HOEL, *University of Virginia*

JOHN C. HORSLEY, *American Association of State Highway and Transportation Officials*  
MARY E. PETERS, *Federal Highway Administration*  
ROBERT E. SKINNER, JR., *Transportation Research Board*  
MICHAEL S. TOWNES, *Hampton Roads Transit, Hampton, VA*

#### *Field of Special Projects*

*Project Committee SP 20-5*

GARY D. TAYLOR, *CTE Engineers (Chair)*  
SUSAN BINDER, *Federal Highway Administration*  
THOMAS R. BOHUSLAV, *Texas DOT*  
DONN E. HANCHER, *University of Kentucky*  
DWIGHT HORNE, *Federal Highway Administration*  
YSELA LLORT, *Florida DOT*  
WESLEY S.C. LUM, *California DOT*  
JOHN M. MASON, JR., *Pennsylvania State University*  
LARRY VALESQUEZ, *New Mexico SHTD*  
PAUL T. WELLS, *New York State DOT*  
J. RICHARD YOUNG, JR., *Post Buckley Schuh & Jernigan, Inc.*  
MARK R. NORMAN, *Transportation Research Board (Liaison)*  
WILLIAM ZACCAGNINO, *Federal Highway Administration (Liaison)*

#### *Program Staff*

ROBERT J. REILLY, *Director, Cooperative Research Programs*  
CRAWFORD F. JENCKS, *Manager, NCHRP*  
DAVID B. BEAL, *Senior Program Officer*  
HARVEY BERLIN, *Senior Program Officer*  
B. RAY DERR, *Senior Program Officer*  
AMIR N. HANNA, *Senior Program Officer*  
EDWARD T. HARRIGAN, *Senior Program Officer*  
CHRISTOPHER HEDGES, *Senior Program Officer*  
TIMOTHY G. HESS, *Senior Program Officer*  
RONALD D. MCCREADY, *Senior Program Officer*  
CHARLES W. NIESSNER, *Senior Program Officer*  
EILEEN P. DELANEY, *Managing Editor*  
HILARY FREER, *Associate Editor*

#### *TRB Staff for NCHRP Project 20-5*

STEPHEN R. GODWIN, *Director for Studies and Information Services*  
DONNA L. VLASAK, *Senior Program Officer*

DON TIPPMAN, *Editor*

JON WILLIAMS, *Manager, Synthesis Studies*  
CHERYL Y. KEITH, *Senior Secretary*

---

---

# NCHRP SYNTHESIS 324

---

---

## Prefabricated Bridge Elements and Systems to Limit Traffic Disruption During Construction

### *A Synthesis of Highway Practice*

#### CONSULTANT

MOHSEN A. SHAHAWY  
Structure Design & Rehabilitation, Inc  
Tallahassee, Florida

#### TOPIC PANEL

FREDERICK D. HEJL, *Transportation Research Board*  
MALCOLM T. KERLEY, *Virginia Department of Transportation*  
SUDHAKAR R. KULKARNI, *Lansing, Michigan*  
MICHAEL G. OLIVA, *University of Wisconsin–Madison*  
MARY LOU RALLS, *Texas Department of Transportation*  
FRANK M. RUSSO, *URS Corporation*  
M.W. SPENCE, *Tidewater–Skanska*  
RICHARD Y. WOO, *Maryland State Highway Administration*  
JOSEPH L. HARTMANN, *Federal Highway Administration (Liaison)*  
JERRY POTTER, *Federal Highway Administration (Liaison)*

#### SUBJECT AREAS

Bridges, Other Structures, Hydraulics, and Hydrology and Highway Operations, Capacity, and Traffic Control

---

Research Sponsored by the American Association of State Highway and Transportation Officials  
in Cooperation with the Federal Highway Administration

---

### TRANSPORTATION RESEARCH BOARD

WASHINGTON, D.C.  
2003  
[www.TRB.org](http://www.TRB.org)

Systematic, well-designed research provides the most effective approach to the solution of many problems facing highway administrators and engineers. Often, highway problems are of local interest and can best be studied by highway departments individually or in cooperation with their state universities and others. However, the accelerating growth of highway transportation develops increasingly complex problems of wide interest to highway authorities. These problems are best studied through a coordinated program of cooperative research.

In recognition of these needs, the highway administrators of the American Association of State Highway and Transportation Officials initiated in 1962 an objective national highway research program employing modern scientific techniques. This program is supported on a continuing basis by funds from participating member states of the Association and it receives the full cooperation and support of the Federal Highway Administration, United States Department of Transportation.

The Transportation Research Board of the National Research Council was requested by the Association to administer the research program because of the Board's recognized objectivity and understanding of modern research practices. The Board is uniquely suited for this purpose as it maintains an extensive committee structure from which authorities on any highway transportation subject may be drawn; it possesses avenues of communication and cooperation with federal, state, and local governmental agencies, universities, and industry; its relationship to the National Research Council is an insurance of objectivity; it maintains a full-time research correlation staff of specialists in highway transportation matters to bring the findings of research directly to those who are in a position to use them.

The program is developed on the basis of research needs identified by chief administrators of the highway and transportation departments and by committees of AASHTO. Each year, specific areas of research needs to be included in the program are proposed to the National Research Council and the Board by the American Association of State Highway and Transportation Officials. Research projects to fulfill these needs are defined by the Board, and qualified research agencies are selected from those that have submitted proposals. Administration and surveillance of research contracts are the responsibilities of the National Research Council and the Transportation Research Board.

The needs for highway research are many, and the National Cooperative Highway Research Program can make significant contributions to the solution of highway transportation problems of mutual concern to many responsible groups. The program, however, is intended to complement rather than to substitute for or duplicate other highway research programs.

---

**NOTE: The Transportation Research Board of the National Academies, the National Research Council, the Federal Highway Administration, the American Association of State Highway and Transportation Officials, and the individual states participating in the National Cooperative Highway Research Program do not endorse products or manufacturers. Trade or manufacturers' names appear herein solely because they are considered essential to the object of this report.**

Project 20-5 FY 2001 (Topic 33-02)  
ISSN 0547-5570  
ISBN 0-309-06972-6  
Library of Congress Control No. 2003114767

© 2003 Transportation Research Board

**Price \$15.00**

#### NOTICE

The project that is the subject of this report was a part of the National Cooperative Highway Research Program conducted by the Transportation Research Board with the approval of the Governing Board of the National Research Council. Such approval reflects the Governing Board's judgment that the program concerned is of national importance and appropriate with respect to both the purposes and resources of the National Research Council.

The members of the technical committee selected to monitor this project and to review this report were chosen for recognized scholarly competence and with due consideration for the balance of disciplines appropriate to the project. The opinions and conclusions expressed or implied are those of the research agency that performed the research, and, while they have been accepted as appropriate by the technical committee, they are not necessarily those of the Transportation Research Board, the National Research Council, the American Association of State Highway and Transportation Officials, or the Federal Highway Administration of the U.S. Department of Transportation.

Each report is reviewed and accepted for publication by the technical committee according to procedures established and monitored by the Transportation Research Board Executive Committee and the Governing Board of the National Research Council.

*Published reports of the*

#### **NATIONAL COOPERATIVE HIGHWAY RESEARCH PROGRAM**

*are available from:*

Transportation Research Board  
Business Office  
500 Fifth Street  
Washington, D.C. 20001

*and can be ordered through the Internet at:*

<http://www.national-academies.org/trb/bookstore>

Printed in the United States of America

# THE NATIONAL ACADEMIES

## *Advisers to the Nation on Science, Engineering, and Medicine*

The **National Academy of Sciences** is a private, nonprofit, self-perpetuating society of distinguished scholars engaged in scientific and engineering research, dedicated to the furtherance of science and technology and to their use for the general welfare. On the authority of the charter granted to it by the Congress in 1863, the Academy has a mandate that requires it to advise the federal government on scientific and technical matters. Dr. Bruce M. Alberts is president of the National Academy of Sciences.

The **National Academy of Engineering** was established in 1964, under the charter of the National Academy of Sciences, as a parallel organization of outstanding engineers. It is autonomous in its administration and in the selection of its members, sharing with the National Academy of Sciences the responsibility for advising the federal government. The National Academy of Engineering also sponsors engineering programs aimed at meeting national needs, encourages education and research, and recognizes the superior achievements of engineers. Dr. William A. Wulf is president of the National Academy of Engineering.

The **Institute of Medicine** was established in 1970 by the National Academy of Sciences to secure the services of eminent members of appropriate professions in the examination of policy matters pertaining to the health of the public. The Institute acts under the responsibility given to the National Academy of Sciences by its congressional charter to be an adviser to the federal government and, on its own initiative, to identify issues of medical care, research, and education. Dr. Harvey V. Fineberg is president of the Institute of Medicine.

The **National Research Council** was organized by the National Academy of Sciences in 1916 to associate the broad community of science and technology with the Academy's purposes of furthering knowledge and advising the federal government. Functioning in accordance with general policies determined by the Academy, the Council has become the principal operating agency of both the National Academy of Sciences and the National Academy of Engineering in providing services to the government, the public, and the scientific and engineering communities. The Council is administered jointly by both Academies and the Institute of Medicine. Dr. Bruce M. Alberts and Dr. William A. Wulf are chair and vice chair, respectively, of the National Research Council.

The **Transportation Research Board** is a division of the National Research Council, which serves the National Academy of Sciences and the National Academy of Engineering. The Board's mission is to promote innovation and progress in transportation through research. In an objective and interdisciplinary setting, the Board facilitates the sharing of information on transportation practice and policy by researchers and practitioners; stimulates research and offers research management services that promote technical excellence; provides expert advice on transportation policy and programs; and disseminates research results broadly and encourages their implementation. The Board's varied activities annually engage more than 4,000 engineers, scientists, and other transportation researchers and practitioners from the public and private sectors and academia, all of whom contribute their expertise in the public interest. The program is supported by state transportation departments, federal agencies including the component administrations of the U.S. Department of Transportation, and other organizations and individuals interested in the development of transportation. **[www.TRB.org](http://www.TRB.org)**

**[www.national-academies.org](http://www.national-academies.org)**

## **FOREWORD**

*By Staff  
Transportation  
Research Board*

Highway administrators, engineers, and researchers often face problems for which information already exists, either in documented form or as undocumented experience and practice. This information may be fragmented, scattered, and unevaluated. As a consequence, full knowledge of what has been learned about a problem may not be brought to bear on its solution. Costly research findings may go unused, valuable experience may be overlooked, and due consideration may not be given to recommended practices for solving or alleviating the problem.

There is information on nearly every subject of concern to highway administrators and engineers. Much of it derives from research or from the work of practitioners faced with problems in their day-to-day work. To provide a systematic means for assembling and evaluating such useful information and to make it available to the entire highway community, the American Association of State Highway and Transportation Officials—through the mechanism of the National Cooperative Highway Research Program—authorized the Transportation Research Board to undertake a continuing study. This study, NCHRP Project 20-5, “Synthesis of Information Related to Highway Problems,” searches out and synthesizes useful knowledge from all available sources and prepares concise, documented reports on specific topics. Reports from this endeavor constitute an NCHRP report series, *Synthesis of Highway Practice*.

The synthesis series reports on current knowledge and practice, in a compact format, without the detailed directions usually found in handbooks or design manuals. Each report in the series provides a compendium of the best knowledge available on those measures found to be the most successful in resolving specific problems.

## **PREFACE**

This report of the Transportation Research Board presents the results of an investigation of the use of innovative prefabricated elements and systems to limit traffic disruption during the construction, rehabilitation, and replacement of bridges. The study was designed to assess and document the impact of these systems and elements on the system design effort, on-site construction time and cost, closure time, and environmental impact. In addition, the study attempted to identify the most suitable prefabricated systems for bridge construction, rehabilitation, and replacement. The synthesis report also looks at the use of fiber-reinforced polymers and other advanced materials and new technologies that are gaining in popularity, but are still in the experimental stages. A review of new systems currently under evaluation is also presented.

Information for this report was derived from a literature review of the state of the practice for prefabricated bridge elements and systems and a survey of transportation agencies in the United States and Canada.

A panel of experts in the subject area guided the work of organizing and evaluating the collected data and reviewed the final synthesis report. A consultant was engaged to collect and synthesize the information and to write this report. Both the consultant and the members of the oversight panel are acknowledged on the title page. This synthesis is an immediately useful document that records the practices that were acceptable within the limitations of the knowledge available at the time of its preparation. As progress in research and practice continues, new knowledge will be added to that now at hand.

# CONTENTS

1	SUMMARY
3	CHAPTER ONE INTRODUCTION State of the Problem and Background, 3 Objectives of the Study, 3 Organization of the Synthesis Report, 3
4	CHAPTER TWO LITERATURE REVIEW History and Utility of Prefabricated Bridges, 4 Practices in Prefabricated Systems for Bridge Rehabilitation, 5 Practices in Prefabricated Systems for Railroad Bridges, 7 Systems and Elements for Rapid Construction, 8 Descriptions of Selected Innovative Prefabricated Systems, 14 Innovative Prefabricated Systems and Elements: International Experience, 23 Use of Fiber-Reinforced Polymers for Prefabricated Systems and Elements, 24
31	CHAPTER THREE PRESENTATION AND ANALYSIS OF THE SURVEY Scope and Objectives of the Survey Questionnaire, 31 Features of the Survey Questionnaire, 31 Evolution of Prefabricated Systems and Elements, 31 Use of Prefabricated Systems in New Bridge Construction, Rehabilitation, and Replacement, 33 Fabrication and Transportation of Prefabricated Bridge Units, 34 Prefabrication Suitability and Need for Development, 36 Effectiveness of Prefabricated Systems and Elements, 36
39	CHAPTER FOUR CONCLUSIONS
40	REFERENCES
42	BIBLIOGRAPHY
44	APPENDIX A SURVEY QUESTIONNAIRE

---

---

## ACKNOWLEDGMENTS

Mohsen A. Shahawy, Ph.D., P.E., Structure Design & Rehabilitation, Inc., Tallahassee, Florida, was responsible for collection of the data and preparation of the report. The author acknowledges Omar Chaallal, Ph.D., P.E., and M. Hassan, Ph.D., P.E., École de Technologie Supérieure, Montreal, Canada, for their valuable experience and input throughout all phases of the study.

Valuable assistance in the preparation of this synthesis was provided by the Topic Panel, consisting of Joseph L. Hartmann, Research Structural Engineer, Turner–Fairbank Highway Research Center, Federal Highway Administration; Frederick D. Hejl, Senior Program Officer, Transportation Research Board; Malcolm T. Kerley, Chief Engineer for Program Development, Virginia Department of Transportation; Sudhakar R. Kulkarni, Lansing, Michigan; Michael G. Oliva, Associate Professor, Department of Civil and Environmental Engineering, University of Wisconsin–Madison; Mary Lou Ralls, State Bridge Engineer, Texas Department of Transportation; Frank M. Russo, Structural Engineer, URS Corporation; M.W.

Spence, Vice President, Engineering, Tidewater–Skanska; Jerry Potter, Senior Structural Engineer, Office of Bridge Technology, Federal Highway Administration; and Richard Y. Woo, Director of Policy and Research, Maryland State Highway Administration.

This study was managed by Stephen Maher, P.E., and Jon Williams, Managers, Synthesis Studies who worked with the consultant, the Topic Panel, and the Project 20-5 Committee in the development and review of the report. Assistance in project scope development was provided by Donna Vlasak, Senior Program Officer. Don Tippman was responsible for editing and production. Cheryl Keith assisted in meeting logistics and distribution of the questionnaire and draft reports.

Crawford F. Jencks, Manager, National Cooperative Highway Research Program, assisted the NCHRP 20-5 Committee and the Synthesis staff.

Information on current practice was provided by many highway and transportation agencies. Their cooperation and assistance are appreciated.

# PREFABRICATED BRIDGE ELEMENTS AND SYSTEMS TO LIMIT TRAFFIC DISRUPTION DURING CONSTRUCTION

## SUMMARY

A significant number of bridges in the United States require rehabilitation or replacement. As a result, increased emphasis is being placed on improving workzone safety and minimizing traffic disruption, while maintaining construction quality and reducing life-cycle costs and environmental impact. The use of innovative prefabricated systems can be an efficient solution, one which would address many of the challenges.

This report presents results of an investigation on the use of innovative prefabricated elements and systems to limit traffic disruption during construction, rehabilitation, widening, or replacement. The main objective of the study was to accumulate existing information on the use of new and innovative prefabricated systems and elements in bridge construction, rehabilitation, and replacement, in regard to the system's design effort, on-site construction time, minimum lane closure time, and minimum environmental impact.

A review of existing literature and available information was conducted. Practices for railroad bridges, as well as international experiences on the use of prefabricated systems and methods that minimize traffic disruption are also covered. A survey questionnaire was then devised. That questionnaire was addressed to the state and province departments of transportation in the United States and Canada to document the state of practice, in their respective states and provinces, on the use of innovative prefabricated systems and elements for bridge construction, rehabilitation, and replacement. Finally, an analysis and a discussion of the questionnaire responses were carried out.

From the literature review and analysis of the survey responses, it is clear that the use of innovative prefabricated elements and systems has generally increased during the last few years. New systems have been developed to prefabricate the decks, the superstructures, and the substructures. The current interest is toward the development of totally prefabricated systems that could accelerate construction time and further minimize traffic disruption. The synthesis report also looks into the use of fiber-reinforced polymers and other advanced materials and new technologies that are gaining in popularity, but still in the experimental stages. The major problems that inhibit the widespread use of innovative systems and elements are identified. To overcome the problems raised in the survey, sustaining research should be pursued to develop better-performing and cost-effective systems. Also, a more efficient collaboration between departments of transportation, consulting engineers, researchers, and contractors is required to share concerns, to orient the research projects, and to generalize the successful aspects leading to standardization and design guidelines for practicing engineers.

## INTRODUCTION

This chapter introduces the problem statement and the background related to the research study. It also presents the objectives of the study and outlines the organization of the synthesis report.

### STATEMENT OF THE PROBLEM AND BACKGROUND

The 2002 biennial report of the Secretary of Transportation to the U.S. Congress (*1*) pointed out the structurally deficient conditions of bridges in the nation and emphasized the urgent need to improve safety and efficiency of highway travel, to avoid the social, environmental, and economic costs associated with a declining system. Approximately 28% of the 590,000 bridges in the United States need to be rehabilitated or replaced. Therefore, rehabilitation and replacement of bridges has become a crucial issue in recent years. Increased emphasis is being placed on improving workzone safety and minimizing traffic disruption associated with highway bridge construction and rehabilitation, while maintaining construction quality and minimizing the life-cycle cost and environmental impact. The use of innovative prefabricated systems and elements to minimize traffic disruption can be a cost-effective solution.

### OBJECTIVES OF THE STUDY

The objectives of the study are twofold. First, it is designed to assess the status of use of new and innovative prefabricated systems and elements, as well as methods, in bridge construction, rehabilitation, and replacement. This assessment is carried out on the basis of system design effort, on-site construction time and cost, minimum closure time, and minimum environmental impact. Second, the study seeks to identify the most suitable prefabricated systems for

bridge construction, rehabilitation, and replacement. It also looks at the problems requiring solutions, with regard to minimizing traffic disruption, life-cycle cost, ease of construction, quality assurance, and durability.

The objectives were achieved by conducting a review of existing literature and available information and by analyzing the data from the responses to a questionnaire.

### ORGANIZATION OF THE SYNTHESIS REPORT

The report is divided into separate chapters. Chapter one presents the project's scope and objectives. Chapter two presents a literature review on the use of innovative prefabricated bridge systems and elements. The effectiveness of prefabricated systems and elements in bridge construction, rehabilitation, and replacement is documented. Practices for railroad bridges, as well as international experiences on the use of prefabricated systems and methods that minimize traffic disruption, are also covered. Emphasis is placed on new and innovative systems and elements not routinely used, which could minimize traffic disruption and improve construction quality and performance. Chapter three looks at how the transportation agencies throughout the United States and Canada are using innovative prefabricated systems and elements and where their emphasis on future plans in this area is placed. That chapter presents the results from a survey questionnaire addressed to state and provincial departments of transportation (DOTs), to evaluate the practices in their respective states and provinces on the use of innovative prefabricated systems and elements for bridge construction, rehabilitation, and replacement. Chapter three also presents the analysis of the questionnaire responses. Chapter four synthesizes the most important findings and presents the conclusions of the study.

## LITERATURE REVIEW

This chapter presents a literature review of the state of practice for the use of innovative prefabricated systems and elements in bridge construction, rehabilitation, and replacement. In addition, the experience gained in the railroad industry, as well as international experience on the use of prefabricated systems and methods to minimize traffic disruption, is summarized. New systems that are currently under evaluation are also presented.

### HISTORY AND UTILITY OF PREFABRICATED BRIDGES

The involvement of the prefabrication industry in bridge construction consists primarily of providing some factory-produced elements. Through mass production of the materials and reduction of on-site construction time, economic benefits are most often achieved. Prefabricated elements commonly produced are prestressed concrete piles, I-beams, box beams, channels, hollow and solid slabs, deck panels, steel I-beams (built-up members and rolled shapes), and box (trapezoidal) beams. Steel trusses and timber structures were once common but are now used sparingly.

Aging bridges requiring repair, rehabilitation, or replacement represent serious problems that have important consequences for bridge users. A full-lane closure is very costly in large urban centers or highways, because of the significant economic impact on commercial and industrial activities. Workzone safety is an important issue to consider in such situations. These situations have led researchers and bridge authorities to investigate more elaborate integral prefabricated systems to improve workzone safety and minimize traffic disruptions. Mass-produced elements can be quickly assembled and could reduce design time and cost by minimizing forming and labor costs and lane closure times. Even at a higher initial cost, the use of prefabricated systems on bridges subjected to a high volume of traffic may be justified, because excessive lane closure times can be avoided. In addition, using a new generation of high-performance materials could help enhance durability and performance.

In the 1990s, prefabrication and prestressing of concrete were put together to give a system of quasi-total prefabrication of bridges, such as the transversely posttensioned double-tee prefabricated and prestressed bridge system (2). These systems were used to replace bridge decks during off-peak traffic, and they showed good performance in terms of minimizing traffic disruption (2,3).

Prefabrication has also been extended to the bridge's substructure, and systems have been used for segmental piers and bents, prefabricated abutments, and composite piles. Currently, it is possible to replace almost any portion of a bridge with a prefabricated element and system, and to complete the installation during off-peak traffic periods with minimum traffic disruption.

A new type of high-performance materials, fiber-reinforced polymers (FRPs), has been developed and used in pilot projects in the bridge industry over the last several years in the United States, Europe, and Asia. The first FRP bridge to carry highway traffic was built near Beijing, China, in 1982, and at least eight Chinese FRP bridges have been built since then (4). In the 1990s, several FRP bridges were built in Europe, Japan, and the United States. The world's first long-span composite structure was built in Scotland over the River Tay at Aberfeldy (5) (Figure 1).



FIGURE 1 Aberfeldy footbridge over the River Tay in Scotland. (Source: <http://www-civ.eng.cam.ac.uk/isegroup/uklocate.htm>.)

The Aberfeldy footbridge linked two halves of a municipal golf course. Built entirely from composite materials, the main span of 64 m (210 ft) consists of a glass fiber-reinforced plastic (GFRP) deck with GFRP towers, and the stay cables are Aramid fiber parallel-lay ropes. Also, a lifting bridge at Bonds Mill, England, providing access over a canal to an industrial estate, has been constructed. The light weight of the GFRP resulted in a lighter structure and allowed simple hydraulic machinery to be used to lift the structure into place.

In the United States, many FRP footbridges have been built in national parks (6). The Laurel Lick Bridge in West Virginia, a short-span highway bridge, has a full-width cellular FRP deck slab supported by six pultruded FRP beams and is supported on FRP piles. Other FRP bridges have been constructed in Virginia and Ohio, and they are being monitored as pilot bridges to verify and provide a better understanding of their behavior under service loads. In many cases, the superstructure segments are prefabricated in the factory and transported to the bridge site, as shown in Figure 2.



FIGURE 2 Fabrication and transportation of FRP bridge segments.

It should be pointed out that although the use of FRP is attracting wide interest, questions on standard specifications, appropriate design methods, and long-term performance need to be answered before these systems are embraced. The high cost of these systems is also an important issue that needs to be addressed in light of life-cycle costs.

#### PRACTICES IN PREFABRICATED SYSTEMS FOR BRIDGE REHABILITATION

Prefabricated systems can be efficiently used in bridge rehabilitation in the case of widening or replacement. Innovations in construction technology, such as prefabricated systems that use conventional materials like concrete, steel, FRP, and other emerging materials, are changing rehabilitation strategies. Although some of the systems are rela-

tively costly, allowance for the rapid replacement of decks or entire superstructures makes it an attractive option. Because the concepts of life-cycle cost analysis and user costs are included in the replacement algorithm, acceptance of the often proprietary and expensive systems will certainly increase.

#### Prefabricated Deck Construction

To rehabilitate the decks of heavily traveled bridges, full-depth prestressed concrete panels are placed transversely on the supporting girders and posttensioned longitudinally. Portions of a deteriorated deck can be removed during night operations and the full-depth panels installed in time to open the structure to morning traffic. Other deck systems offer similarly rapid construction methods with the advantages of reduced dead load and enhanced durability. In 1999, for example, approximately 14,000 ft<sup>2</sup> of deteriorating bridge deck of Route 7 over Route 50 bridges in Fairfax County, Virginia, required replacement (7). Virginia's DOT opted to use full-depth prefabricated concrete deck panels to satisfy community concerns with respect to reduction in the level of service. Operating only at night, work crews saw cut sections of the existing deck, lifted and removed them by crane, and immediately installed new deck panels that matched the deck cavity. A rapid-setting concrete overlay was then placed, and after only 3 h the bridge was able to support full traffic. The bridge was completely open to traffic during the day.

In 2001, Route 29 over Sugar Creek in Illinois required the redecking of an existing 252.9-ft (77.13-m)-long, 37.375-ft (11.4-m)-wide five-span bridge (7). The existing steel beams were reused and made composite with the prefabricated deck panels. A total of 29 panels were laid across the length of the bridge. The panels were connected by shear keys and posttensioned longitudinally. Traffic delays were minimized as a result of the speeding up of the construction time.

#### Proprietary Systems

Numerous proprietary deck and superstructure replacement systems are currently being marketed or evaluated (8). Although explicitly specifying the following proprietary systems may present problems for public agencies with regard to the open bid process, they do represent current state of the art. Other systems may also be available, because the field is rapidly evolving.

##### *Exodermic Bridge Decks*

The Exodermic bridge deck system is a composite modular system that is lightweight and strong. It consists of a rein-

forced concrete slab on top of, and composite with, an unfilled steel grid. Because a steel grid is used instead of a full-depth concrete slab, Exodermic decks typically are only 50% to 65% as heavy as conventionally reinforced concrete decks. Superior economy and durability are claimed. For example, the Governor Malcolm E. Wilson Tappan Zee Bridge over the Hudson River, about 13 mi north of New York City, needed more than 250,000 ft<sup>2</sup> of redecking (8). The 16,000-ft Tappan Zee Bridge carries approximately 130,000 vehicles per day and is considered a critical route for commuters. The New York State Thruway Authority required that work projects allow all lanes of traffic to be open for morning and evening peak hours. In 1998, the redecking project of the east deck truss was executed at night, allowing all seven lanes to be open to traffic by 6 a.m. The project used proprietary full-depth deck panels, 7½-in. thick overall. Twelve hundred of the exodermic panels were required. The Exodermic deck panels provide the durability and strength of reinforced concrete, but weigh 35% to 50% less, and can be placed rapidly with minimum traffic disruption.

#### *Aluminum Bridge Decks*

Reynolds Metals developed a bridge deck system that offers a rapid installation using only a light crane. It also has the proven durability and light weight of aluminum components (8). The deck weight is approximately 25% of that of a concrete deck, which allows for a significant increase in live-load capacity. The system has been initially penalized because of its high cost; however, it may prove to be viable when its advantages are considered in selecting a design for high-volume locations.

Figure 3 shows the historic Corbin Bridge in Huntingdon County, Pennsylvania. The bridge was renovated in 1996 with a prefabricated orthotropic aluminum deck. The live load-carrying capacity was increased from 7 to 20 tons as a result of the reduction of the weight of the deck (9).

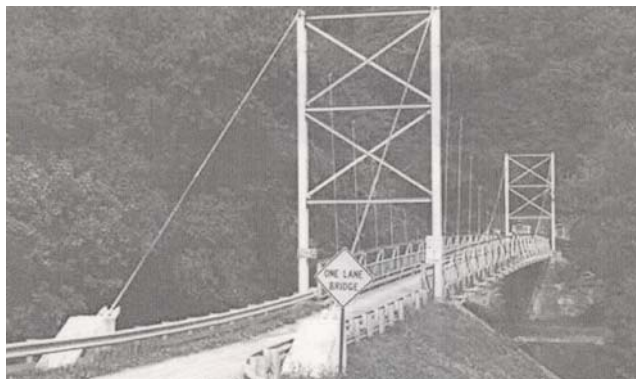

FIGURE 3 Corbin Bridge aluminum deck. (Source: [www.aluminum.org/Content/NavigationMenu/The\\_Industry/Building\\_Construction\\_Market/Bridges/Bridges.htm](http://www.aluminum.org/Content/NavigationMenu/The_Industry/Building_Construction_Market/Bridges/Bridges.htm).)

#### *Prefabricated Channel Concrete Sections*

In 1990, Jean Muller International introduced a new segmental system called the Channel Bridge System (8). In this system, the supporting beams of the channel cross section serve as traffic barriers above the deck, which increases the under clearance. Longitudinal and transverse prestressing provides strength and durability by maintaining compressive stresses in the concrete when loaded. Segments 8.2 ft (2.5 m) long can be connected to form 114.75-ft (35-m)-long spans.

The state of New York was the first to use this system in the United States. In 1997, two bridges were replaced with the Channel Bridge System: (1) Carpenter Road over the Metropolitan Transportation Authority Metro North Railroad in East Fishkill in Dutchess County and (2) State Route 17M over State Route 17 in Wallkill in Orange County (10).

Carpenter Road over Metro North is a 86.3-ft (26.3-m), single-span overpass bridge. State Route 17M is a 73.8-m, three-span continuous overpass bridge with span lengths of 105.3 ft (32.1 m), 104.6 ft (31.9 m), and 28.5 ft (8.7 m). Figure 4 shows the first two channel segments of the Carpenter Road Bridge.



FIGURE 4 Installation of the first two channel segments of the Carpenter Road Bridge. (Source: <http://www.tfhrcc.gov/pubrds/septoct98/channel.htm>.)

#### *Prefabricated Steel Systems*

The Quadricon system is currently under evaluation by the Highway Innovative Technology Evaluation Center (8). In this system, a variety of bridge structures can be formed from identical components that can be combined to form a wide range of span lengths and carrying capacities. Quadricon bridges have the advantage of being lightweight and are made of high-performance materials.

**PRACTICES IN PREFABRICATED SYSTEMS FOR RAILROAD BRIDGES**

Delays in railway bridge construction, rehabilitation, or replacement are generally limited to a strict minimum, because railway deviation is difficult and expensive. The prefabrication process is most suitable for accelerating the bridge construction or rehabilitation. Such bridges can be of prefabricated concrete or steel. The first prefabricated prestressed concrete railway bridges were constructed in the 1950s (11). This long experience has allowed prefabricated elements and systems to be standardized for integrated bridge deck construction. The gain in experience to limit traffic disruption and the environmental impact at the construction site could be transferred to and used in road bridges. Traditional types of decks are open deck steel span railway bridges (Figure 5), steel deck plate girder railway bridges with prefabricated prestressed concrete slabs (Figure 6), and through plate girder railway bridge decks (Figure 7). All could be easily prefabricated and assembled in situ with minimal traffic disruption.

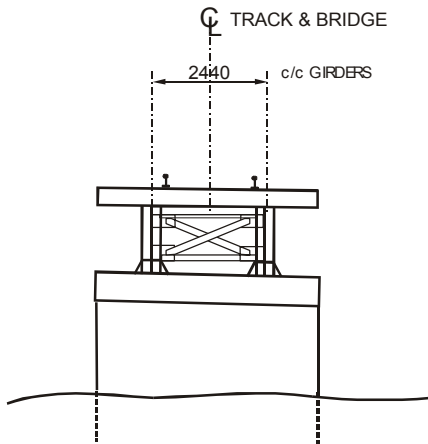

FIGURE 5 Open deck steel span railway bridge.

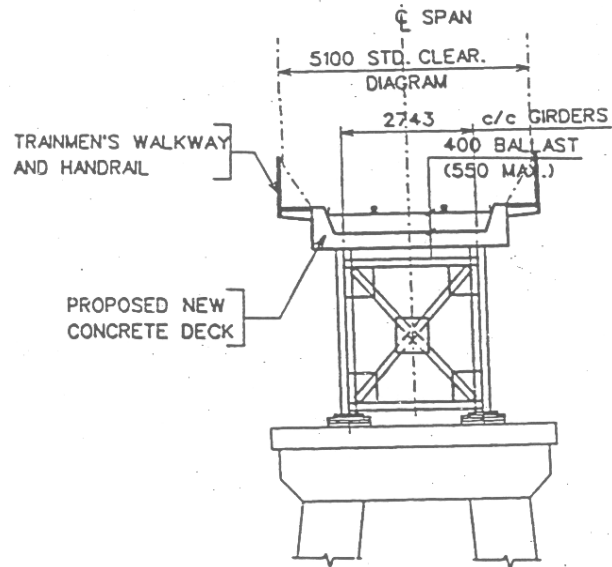

FIGURE 6 Steel deck plate girder railway bridge with prefabricated prestressed concrete slab.

The new tendency in construction is to have integral full-depth prestressed prefabricated concrete decks. Figure 8 shows a railway bridge deck composed of four prefabricated prestressed box girders tied together with transverse posttensioning bars through the diaphragm. This was found to be more competitive than using other traditional steel-concrete systems. This system was adopted in the Du Chene Bridge in Canada (11,12). The same concept can be used with a channel-type girder in place of the box girder, further facilitating inspection (Figure 9). This type of bridge was used for the Rawdon River crossing near Kin-sac, Nova Scotia, Canada, in 1990.

The prefabricated full-depth panels used in deck replacement allow minimal traffic disruption by limiting construction time. For example, the Spur (loop) 326 bridge at AT&SF Railway, built in 1958 and located in downtown

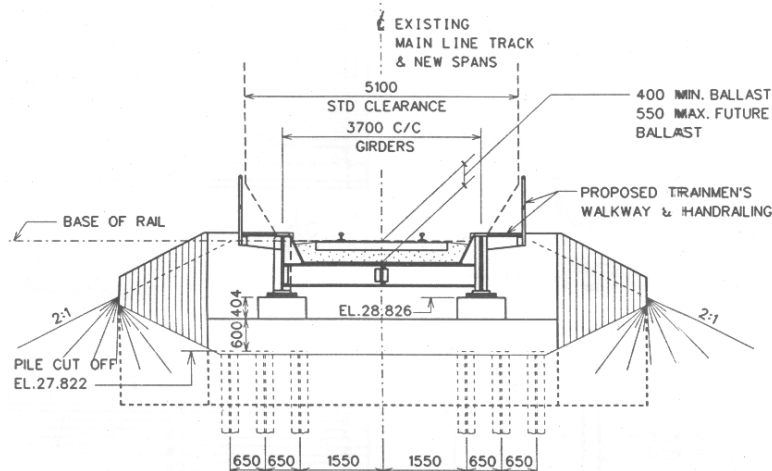

FIGURE 7 Through plate girder railway bridge deck.





FIGURE 11 Dead Run and Turkey Run bridges. (Source: [www.aashtotig.org](http://www.aashtotig.org); courtesy: FHWA.)

to be kept open to daily traffic from Monday morning to Friday evening. The construction sequence meant that workers closed the bridge on Friday evening, saw cut the existing deck into transverse sections that included curb and rail, removed the cut sections of the deck, set new prefabricated panels, stressed the longitudinal tendons after all panels in a span were erected, grouted the area beneath the

panel and above the steel beam, and opened the bridge to traffic by Monday morning. This construction sequence allowed the complete replacement of one bridge span per weekend.

Innovative deck systems, such as full-depth prestressed deck panels, and transversally posttensioned double-tees, in addition to FRP modular decks, are presented and described with case studies later in this chapter. Table 1 lists bridge projects that used prefabricated partial- or full-depth decks.

### Fiber-Reinforced Concrete Arch Panel Decks

Fiber-reinforced concrete (FRC) deck slabs without internal tensile reinforcement are also known as steel-free and corrosion-free deck slabs. The cast-in-place version of these slabs has already been applied to four highway bridges in Canada. The prefabricated version of steel-free deck slabs was developed after extensive experimental investigation. Tests of full-scale prefabricated slab prototypes have been implemented in one forestry bridge and one marine structure.

TABLE 1  
BRIDGES WITH INNOVATIVE DECKS

Bridge	Location	Prefabricated Elements (full and partial depth)	Date of Construction
Lavaca Bay Causeway	Over the Lavaca Bay, Texas	Girder/slab/diaphragm/parapet walls prefabricated and prestressed; prefabricated monolithic beams	1961
Spur Overpass over AT&SF Railroad	Downtown Lubbock, Texas	Prefabricated full-depth concrete deck panels	1988
US-27 over Pitman Creek	Somerset, Kentucky	Full-depth concrete deck panels	1993
SH-249/Louetta Road Overpass	Houston, Texas	Total substructure systems; pretensioned partial-depth concrete deck panels	1994
US-59 under Dunlavy, Hazard, Mandel, and Woodhead Streets	Houston, Texas	Prefabricated prestressed concrete deck panels	1995
Troy–Menands Bridge	Rensselaer and Albany Counties, New York	Exodermic deck panels	1995
I-45/Pierce Elevated	Downtown Houston, Texas	Bent caps; prestressed partial-depth deck panels; prestressed I-beams	1997
Tappan Zee Bridge	Hudson River, 13 miles north of New York City, N.Y.	Exodermic deck panels	1998
Dead Run and Turkey Run bridges	George Washington Memorial Parkway, Virginia	Prefabricated concrete; posttensioned full- depth deck panels	1998
Route 7 over Route 50	Fairfax County, Virginia	Prefabricated full-depth deck panels	1999
Route 57 over Wolf River	Fayette County, Tennessee	Bent caps; prestressed I-beams; prestressed partial-depth deck	1999
Keaiwa Stream Bridge	Route 11 near Pahala, Hawaii	Prestressed partial-depth concrete deck	2000
I-5/South 38th Street Interchange	Tacoma, Washington	Partial-depth concrete deck panels; posttensioned tub girders	2001
Illinois Route 29 over Sugar Creek	Sangamon County, Illinois	Full-depth posttensioned deck panels, parapets	2001
SH-66/Lake Ray Hubbard	Near Dallas, Texas	Bent caps; prestressed I-beams; prestressed partial-depth deck panels	2002
Wesley Street Bridge	Ragsdale Creek in Jacksonville, Texas	Prefabricated/prestressed slab beams	2002
SH-36 over Lake Belton	Near Waco, Texas	Bent caps; prestressed U-beams; prestressed partial-depth deck panels	2004

(Source: [www.aashtotig.org](http://www.aashtotig.org).)





FIGURE 13 George P. Coleman Bridge. (Source: [www.aashtotig.org](http://www.aashtotig.org); courtesy: Virginia DOT.)

and then transported by barge to the construction site. Six old spans were removed and replaced with the new bridge spans in just 9 days.

Another example is the replacement of the superstructure of the I-95 James River Bridge, with minimal impact on motorists (16). The bridge carries approximately 110,000 vehicles per day through the city of Richmond. After considering alternatives, the Virginia DOT opted for night-only construction. For most spans, preconstructed composite units, which include an 8¾ in. (222.25 mm) deck over steel plate girders, were prefabricated at a nearby casting yard and then transported to the work site. Work crews cut out the old bridge span and removed it, prepared the gap for the new prefabricated units, and set the new prefabricated units in place. The bridge superstructure, completed in 2002, was replaced without the highway's ever being closed during peak hour traffic.

The replacement of a through girder bridge over a busy commuter railroad presents a challenge for DOTs. In 2000, the Main Street over Metro North Railroad located in Tuckahoe, New York, presented such a challenge for the New York State DOT: maintaining two-way traffic, conducting all work between 2 a.m. and 4 a.m. on weekends to limit disruptions for rail commuters and adjacent stores, maintaining utility lines while relocating them on the new bridge, and raising the railroad vertical clearance 5 in. without affecting the street profile. The New York State DOT chose a commercial system of prefabricated and prestressed concrete and steel composite superstructure modules (Figure 14) that allowed for smaller beams than conventional construction. This helped the DOT attain the necessary increased vertical clearance and had a brief installation time (17).

#### *Prefabricated Substructures*

Prefabricated substructure design provides an opportunity to apply advanced technologies and new materials to

bridge systems. Specifically, the prefabricated substructure system consisting of segmental piers and bents offers an alternative that combines prefabricating and high-performance materials, resulting in rapid construction, durable performance, and an attractive appearance.



FIGURE 14 Main Street over Metro North Railroad. (Source: [www.aashtotig.org](http://www.aashtotig.org); courtesy: New York State DOT.)

#### *Bent Caps and Columns*

The term “bent cap” refers to the horizontal member at the top of the columns that supports the superstructure. Cast-in-place bent caps require extensive formwork and curing times. If these caps are fabricated off-site, curing times are not a factor. As a result, bridge owners and contractors are increasingly using prefabricated bent caps. For over water bridges, the bent caps reduce the amount of time that workers need to operate over water. Also, the use of prefabricated bent caps for bridges over existing roadways minimizes the required formwork and reduces disruption to traffic on the lower roadway. For bridges with job-site constraints, such as power lines that affect workzone safety, the use of prefabricated bent caps can limit the amount of time that workers are at risk. The US-290 Ramp E-3 bridge project, in Austin, Texas, is a relevant example (Figure 15). After the contract had been let and work started, it became clear that formwork for the proposed cast-in-place cap would interfere with traffic and require closing of the ramp for an estimated 7 days (18), with the Texas DOT’s (TxDOT’s) approval, the contractor instead prefabricated the straddle bent cap at the work site and lifted it into position. When it was in place, workers posttensioned bars and grouted the cap-to-column connections. The time necessary for closure of the ramp was reduced from an estimated 7 days to 4 h.

The SH-66/Lake Ray Hubbard bridge, near Dallas, Texas, is another relevant example of the use of prefabricated bent caps to widen the narrow two-lane crossing of SH-66 over Lake Ray Hubbard, which had become a congested route (Figure 16). Construction began in 2000 on a pair of con-



FIGURE 15 US-290 ramp E-3 bridge. (Source: www.aashtotig.org.)



FIGURE 16 SB-66/Lake Ray Hubbard Bridge. (Source: www.aashtotig.org; courtesy: TxDOT.)

ventional prestressed concrete I-beam bridges with lengths of 10,280 and 4,360 ft (19). After the project was let for construction, the contractor suggested prefabricating the substructure bent caps as an alternative to the original design of cast-in-place multicolumn bents, to reduce the time that workers would need to operate near power lines. The TxDOT designed a prefabricated bent cap option that in-

cluded a cap-to-column connection and a specific construction procedure that allowed early placement of caps and prestressed beams, based on achieved cap concrete and cap grout connection strength. The column-to-cap connection included reinforcing steel dowel bars that protrude from the columns into the prefabricated caps by means of open plastic ducts that are grouted after cap placement. This project implied the prefabrication of a total of 43 bent caps. Table 2 lists the bridges that have used prefabricated bent caps.

Bridge construction times can be greatly reduced by using prefabricated columns on cast-in-place footings. Columns can be segmental, posttensioned, and either hollow or concrete filled. For replacement of the Lake Ray Hubbard Bridge's four-span, two-lane, freeway overpass, the existing profile grade could not be raised. Designers chose box beams, which provided a shallow structure depth and eliminated most deck formwork. Careful control of pile leads for plumb during 24-in. pile driving in soft clay allowed for the placement of piles without templates to within 2 in. of the planned location. All construction took place with brief, partial, and phased road closures. The existing low-clearance bridge was demolished and the new bridge was completed in 10 days.

Another example is the Dallas/Fort Worth (DFW) International Airport People Mover located in Dallas/Fort Worth Metroplex, Texas, and scheduled to be completed in 2004 (Figure 17) (19). In this example, the DFW Airport decided to upgrade its airport people mover system to accommodate new terminals and an increased passenger count. The new people mover will transport people from the farthest terminals to the main terminal in 11 min. Furthermore, the cost per day of casting conventional concrete columns with forms and guy wires for the reinforcing is high, owing to space that would be used on the airport apron. Instead of closing aircraft terminals and gates, the DFW Airport People Mover Team decided to design and build a prefabricated posttensioned segmental system of columns.

TABLE 2  
BRIDGES THAT HAVE USED PREFABRICATED BENT CAPS

Bridge	Location	Prefabricated Elements	Date of Construction
Edison Bridge	Fort Myers, Florida	Columns and bent caps	1991
SH-361 over Redfish Bay and Morris-Cummings Cut	Aransas County, Texas	Bent caps	1994
US-290 Ramp G	Austin, Texas	Bent caps	1996
I-45/Pierce Elevated	Downtown Houston, Texas	Bent caps, decks	1997
Route 57 over Wolf River	Fayette County, Tennessee	Bent caps, decks	1999
Beaufort and Morehead Railroad Trestle Bridge	Between Morehead City and Radio Island, North Carolina	Bent caps	1999
SH-66/Lake Ray Hubbard	Near Dallas, Texas	Bent caps, decks	2002
SH-36 over Lake Belton	Near Waco, Texas	Bent caps, decks	2003



FIGURE 17 Dallas/Fort Worth International Airport people mover under construction. (Source: [www.aashtotig.org](http://www.aashtotig.org); courtesy: STOA/Carlos + Law, AE.)

### Total Substructure Systems

Bridge design can combine the bent cap and its column into one prefabricated unit, eliminating the need for individual substructure elements and using a prefabricated approach for the entire substructure. The SH-249/Louetta Road overpass, located in Houston, Texas, and completed in 1994, is an example of a bridge that used the total prefabricated substructure system (Figure 18) (20). The superstructure consists of simple-span, pretensioned, trapezoidal-shaped, 54-in. U-beams, as well as prefabricated pretensioned deck panels supported on the U-beams' top flanges with a cast-in-place composite concrete topping. The bridges are three spans each, nominally 130 ft per span. At the interior bents, a single posttensioned pier supports each beam.

A prefabricated substructure system of segmental piers and bents is described in detail later in this chapter. It is versatile, with applications to a wide variety of bridge widths and heights. Prefabricated substructures can be easily standardized to further improve their economy, particularly for short- and moderate-span bridges. For some designs, the proposed prefabricated substructure system will be economical and competitive with cast-in-place alternatives.



FIGURE 18 SH-249/Louetta Road overpass. (Source: [www.aashtotig.org](http://www.aashtotig.org); courtesy: TxDOT.)

According to recent studies sponsored by the TxDOT, standardization of prefabricated substructure bridge systems could result in a construction cost similar to that for cast-in-place substructures (using inverted T-bent caps). These studies further estimate that the construction time could be roughly 50% less than when using cast-in-place construction (21). The benefits of this system are evident in a recent project in which using prefabricated pier caps resulted in a briefer construction time and an early completion bonus of \$1,600,000 (21). The value of a day of construction time saved was estimated at \$53,000. In some cases, in congested areas and highways, the cost savings from shorter construction time could far outweigh the cost differences possible with competing substructure systems. In addition, prefabricated systems are manufactured at the factory under tight quality control, where accurate cover and improved mixing, placement, and curing methods are closely monitored. Such tight control is most often associated with enhanced durability and therefore a reduction in life-cycle costs.

### Prefabricated Bridges

Prefabricated bridge systems offer the maximum advantage for rapid construction and depend on a range of prefabricated bridge elements that are transported to the work site and assembled in a rapid-construction process. The case of Baldorioty de Castro Avenue Overpasses in San Juan, Puerto Rico, is a relevant example of a totally prefabricated bridge system (22) (Figure 19). To ease congestion on a road that carries more than 100,000 vehicles per day, the Department of Public Works provided two overpasses at each of two intersections: two that were 700 ft long and two 900 ft long. To minimize traffic disruption the project was built in two stages. Piles were driven and footings cast with special forms to facilitate connections. Then, the prefabricated bridge components were erected and posttensioned: box piers positioned and

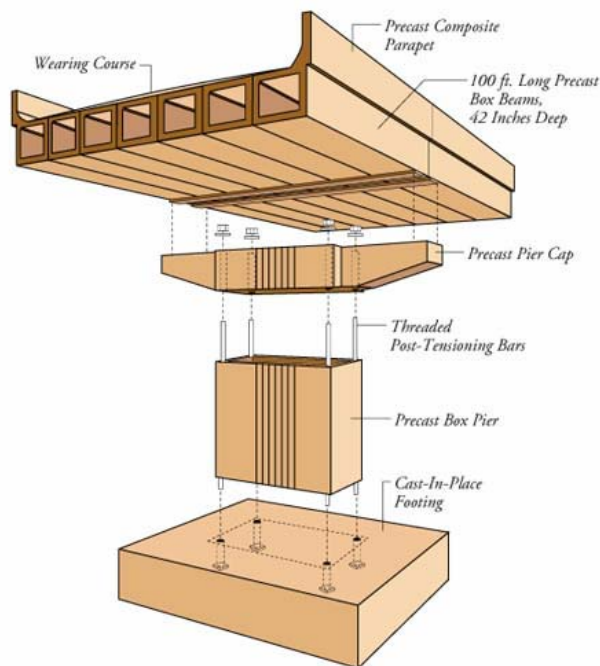

FIGURE 19 Baldorioty de Castro Avenue overpasses.  
(Source: www.aashtotig.org; courtesy: Departamento de  
Transportación y Obras Públicas de Puerto Rico.)

posttensioned to the footings, caps were placed, and piers were vertically posttensioned. When the first two piers were in place, the 100-ft-long superstructure box beams were set in place. Each span then was posttensioned transversely as it was completed. The first bridge was erected in 36 h and the others took as little as 21 h. Table 3 lists examples of bridges that have been built using the totally prefabricated bridge system.

TABLE 3  
BRIDGES THAT HAVE USED A TOTAL PREFABRICATED  
SYSTEM

Bridge	Location	Date of Construction
Linn Cove Viaduct	Grandfather Mountain, North Carolina	1983
Baldorioty de Castro Avenue Overpasses	San Juan, Puerto Rico	1992
Route 9/Metro North Pedestrian Bridge	Croton-on-the-Hudson, New York	1998
Cross Westchester Expressway Viaducts	Westchester County, New York	1999

### DESCRIPTIONS OF SELECTED INNOVATIVE PREFABRICATED SYSTEMS

This section will cover some examples of larger prefabricated, fully integrated systems and other components currently in use by the DOTs. Pilot projects using such systems

and conclusions on their performance will be primarily reported.

### Full-Depth Prefabricated Prestressed Deck Panels

Redecking with prefabricated modular deck panels is a viable method of deck replacement that minimizes traffic disruption, reduces total construction time, and allows for better quality control of concrete. This construction method allows opening part of the bridge under construction to traffic. In addition, nighttime redecking with prefabricated concrete modular panels, although slightly more costly than daytime redecking, can further minimize disruption of traffic. Also, the existing deck could be replaced in stages. In each stage, a portion of the transverse section is removed and replaced along the full length of the bridge, while other lanes are maintained open for traffic, as illustrated in Figure 20. The example of the redecking of a bridge at Route 7 over Route 50 in Fairfax County, Virginia, will be used to illustrate and explain the construction method of full-depth prefabricated prestressed deck panels (1).

#### Description of Deck Panels

Different panel shapes were designed to fit the construction stages and skewed ends of the deck slab, while conforming to the weight limit for transportability and ease of construction. Lightweight concrete was used in the fabrication of the panels, to compensate for the additional weight of the overlay.

The elevations of the panels are adjusted by a leveling bolt system (Figure 21). Each panel has four bolts, one in each corner, threaded through cast-in-place sockets. These bolts temporarily bear on the existing girders and their heights could be easily adjusted using a common wrench. After the panel is positioned, the haunch between the panel and the girder is built with a high-early-strength concrete.

Continuity across the transverse joints is provided by a posttensioned, grouted shear key (Figure 22). High-early-strength grout is used in the shear key. The gap at the bottom of the shear key compensates for the dimensional tolerance of the panels. Posttensioning provides compression at the transverse joint applied by the posttensioning strands that run along ducts placed at middepth of the panels. The ducts are spliced at each transverse joint in small blockouts. After posttensioning, the ducts are pressure grouted and the blockouts are filled with the high-early-strength concrete. Welded sliding shear plates are installed across each transverse joint to improve shear transfer (Figure 23).

The longitudinal joints between the construction stages are located at the girders to minimize shear forces at the

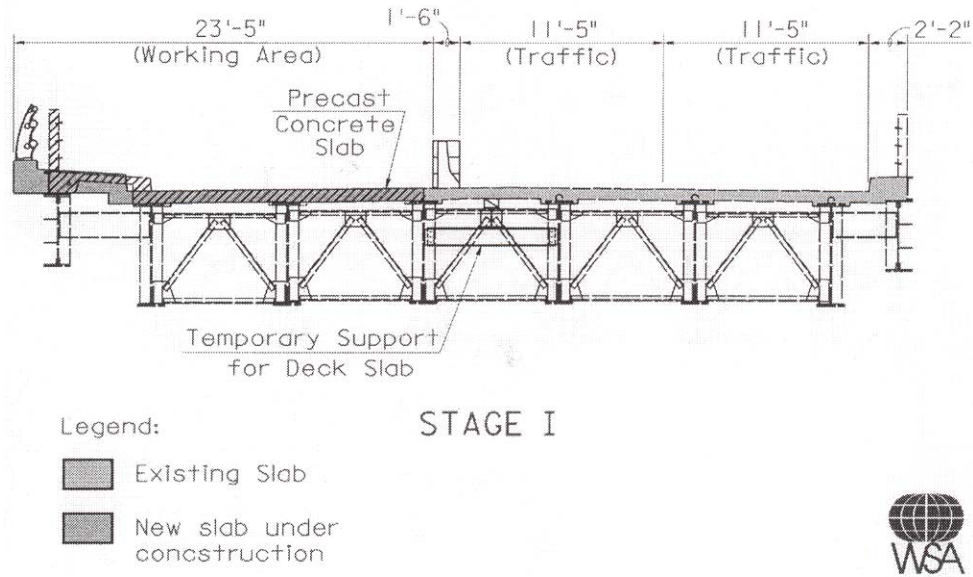

FIGURE 20 Cross section of bridge during first stage of slab replacement. [Source: Babaei et al. (1).]

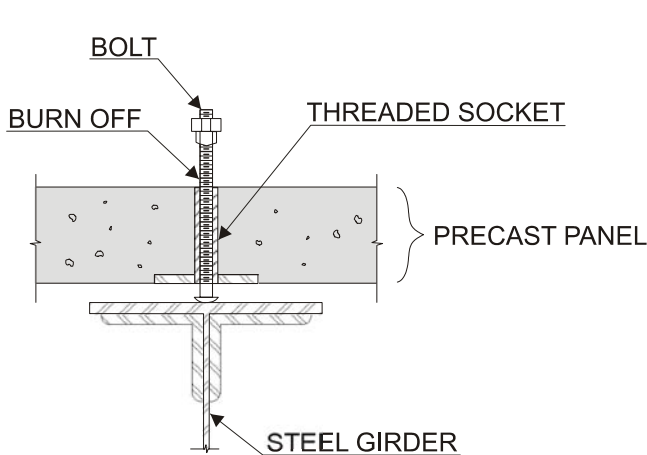

FIGURE 21 Leveling bolt system. [Source: Babaei et al. (1).]

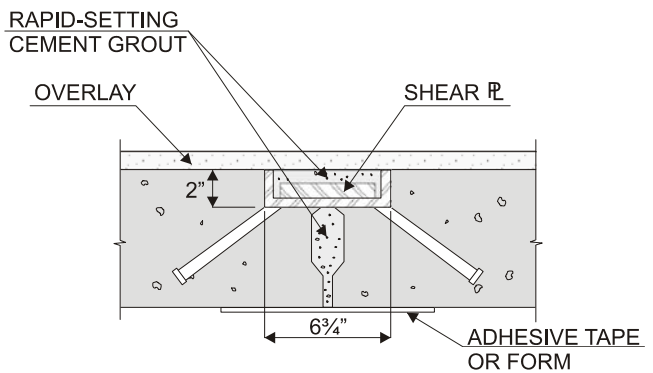

FIGURE 23 Welded sliding shear plates. [Source: Babaei et al. (1).]

transverse bars embedded in a strip of partial-depth, high-early-strength, cast-in-place concrete (Figure 24).

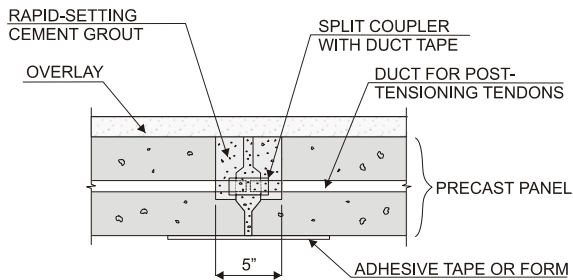

FIGURE 22 Posttensioning duct. [Source: Babaei et al. (1).]

longitudinal joints of the panels. The negative moment transfer at the longitudinal joints is provided by spliced top

*Composite Action*

The panels have shear stud blockouts located over the girders. The composite action is accomplished by the studs welded to the girders in these blockouts (Figure 25). The blockouts have a tapered wall to prevent uplift of the panel (Figure 26) and are filled with the high-early-strength concrete. Note that the shear stud blockouts are filled after posttensioning to avoid subjecting the superstructure to positive moments from posttensioning.

*Temporary Restraint*

An important aspect of the design is the temporary restraint of the panels against movements caused by daytime traffic

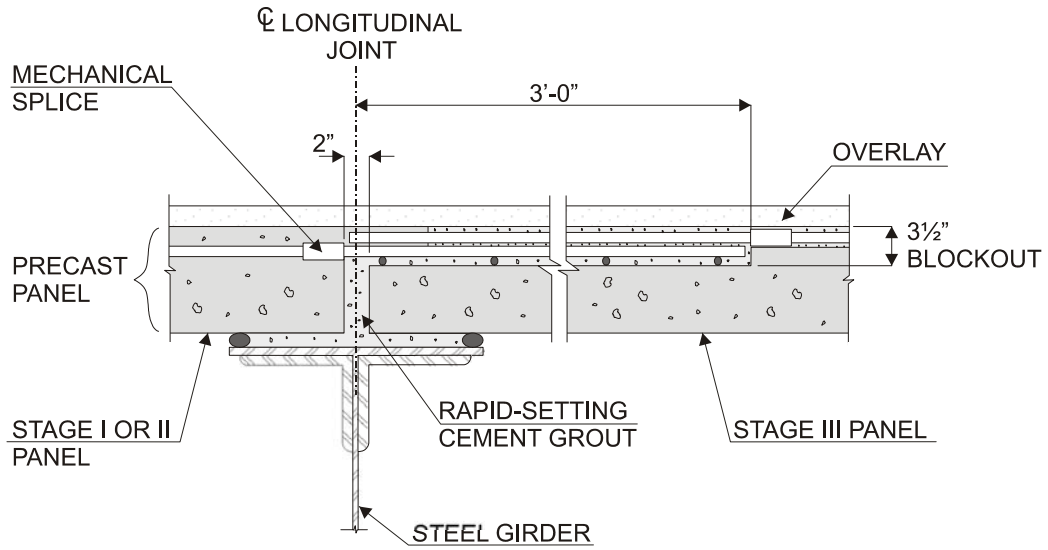

FIGURE 24 Longitudinal connections. [Source: Babaei et al. (1).]

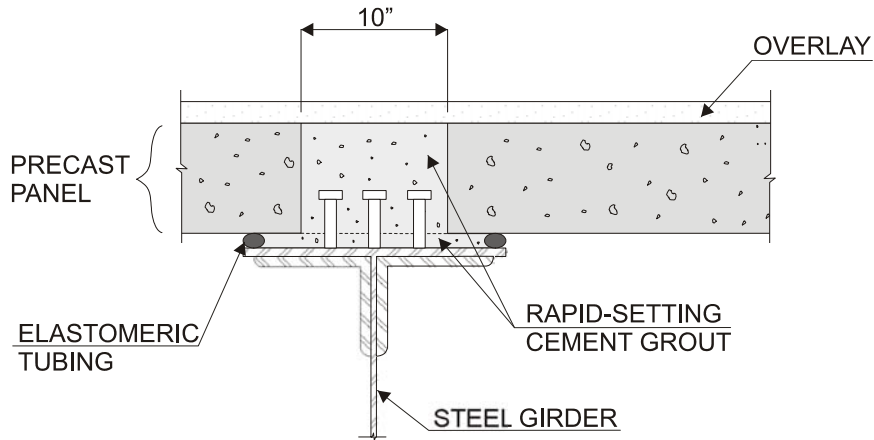

FIGURE 25 Regular shear stud blockout. [Source: Babaei et al. (1).]

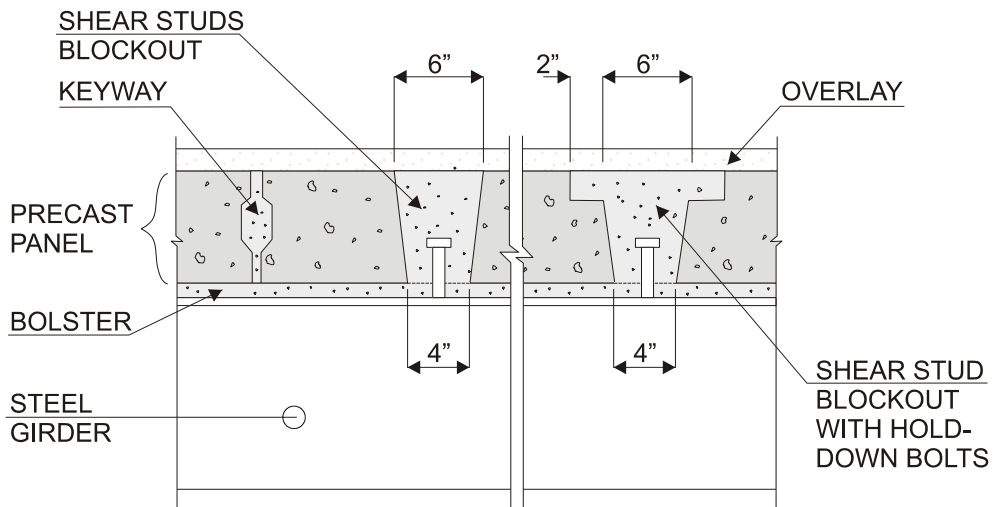

FIGURE 26 Longitudinal section, shear stud blockouts, and shear key. [Source: Babaei et al. (1).]

before posttensioning. As shown in Figure 26, two types of shear stud blockouts are used: (1) regular blockouts and (2) blockouts with hold-down bolts. The second type of blockout is used to temporarily restrain the panels against movements caused by traffic (Figure 27). To provide this temporary restraint, two bolts are welded to the girder in the blockout in place of the two exterior shear studs. These bolts secure a temporary hold-down plate in the blockout and restrain vertical and horizontal panel movements. The blockout is temporarily filled with sand and topped with asphalt concrete in preparation for traffic. After posttensioning, the asphalt concrete, filler sand, and hold-down plate are removed. Then, the hold-down bolts are cut to size and the blockout is filled with high-early-strength concrete.

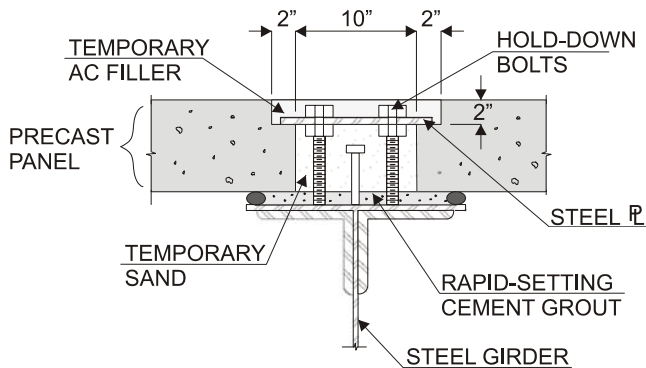

FIGURE 27 Temporary panel restraint for traffic. [Source: Babaei et al. (1).]

Panels are fabricated based on the as-built dimensions and shipped and stored near the job site before construction (Figure 28). After saw cutting and removal of the existing slab, the panels are lowered into position and placed on the existing steel framing (Figure 29). The final elevation of the top of the deck is achieved by adjusting the leveling bolts. The haunch between the beam flange and the panel soffit is built with a fluid, high-early-strength concrete fed through the blockouts located over the beam. Composite construction is initiated by welding studs to the beam flange in the same blockouts prior to building the haunch. The temporary hold-down bolts and plates are installed in selected blockouts to prevent panel movements caused by traffic.

After all panels are installed, they are posttensioned in the longitudinal direction to ensure tight transverse joints between the panels. Finally, an overlay is applied on the entire deck to provide a smooth ride over the panel joints and to waterproof the joints. The overlay consists of asphalt concrete with a waterproofing membrane. The waterproofing membrane has the ability to bridge the panel joints and prevent reflection of the joints in the asphalt concrete.



FIGURE 28 Stored panels near job site of bridges at Route 7 over Route 50, Fairfax, Virginia. [Source: Babaei et al. (1).]

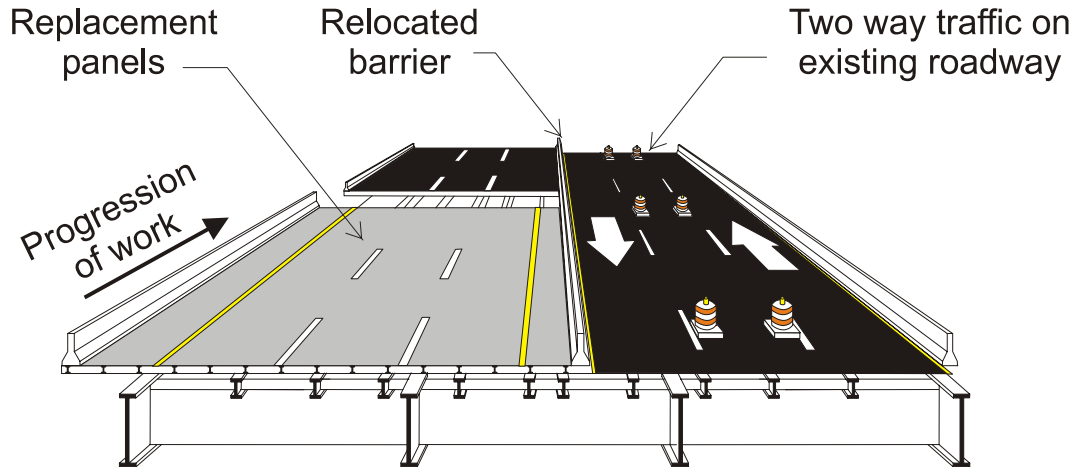

FIGURE 29 Installation of new panel of bridges at Route 7 over Route 50, Fairfax, Virginia. [Source: Babaei et al. (1).]

#### Woodrow Wilson Bridge

The Woodrow Wilson Bridge carries Interstate I-95/495 over the Potomac River in Washington, D.C. The states of Maryland and Virginia and the District of Columbia jointly maintain the structure. The bridge, which carries more than 110,000 vehicles each day, was built in 1962 and redecked in 1984 (Figure 30). It is 5,900 ft long, with span lengths from 62 to 184 ft. The bridge carries six lanes of traffic on four main girders with floor beams at 16 to 26 ft on center. Five rolled beam stringers that are continuous over the floor beams carry each roadway.

The replacement deck system is composed of 46-ft-7 $\frac{1}{4}$  in.-wide transversely posttensioned, lightweight, precast concrete deck units (Figure 31) (23). Each precast deck unit is supported on the outside girder and the five stringers.



### Replacement in progress with maintenance of traffic

FIGURE 30 Redecking view of the Woodrow Wilson Bridge.

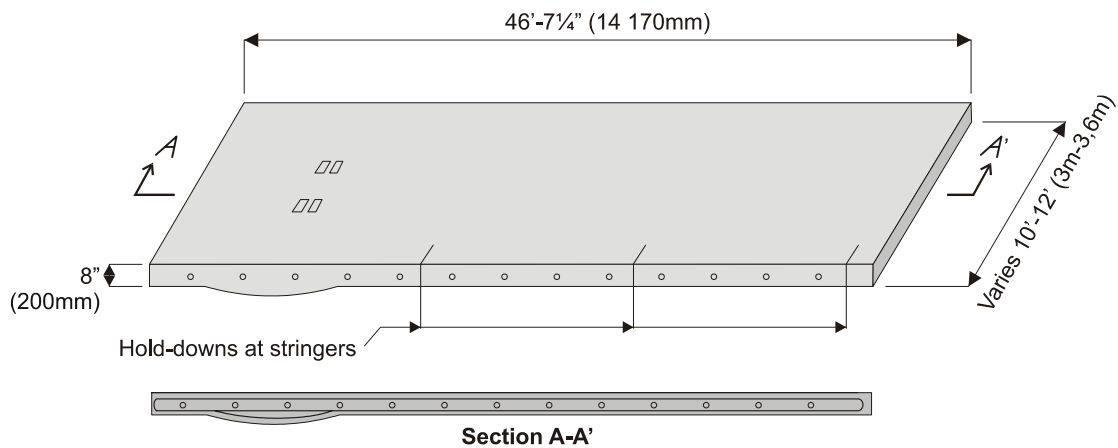

### Typical panel

FIGURE 31 Prefabricated concrete deck panel.

Lightweight precast Jersey-shape parapets were bolted to the deck panels and the existing Jersey median barrier was rebolted through the centerline joint. A 1½-in. asphalt-wearing course was provided over the precast deck units. The length of a typical panel varies from 10 to 12 ft with a thickness of 8 in., except over the outside girder where the thickness is 13 in. Precast panels (1,026) weighing approximately 22 tons were used to redeck the structure. The completed deck was posttensioned in the transverse and longitudinal directions with strand tendons. The deck panels are supported on polymer concrete between the panel and stringers and held in place with bolted hold-down devices.

The primary goal of the project was to minimize disruption to traffic during deck replacement. The contractor began work on the project on December 2, 1982, and completed work on September 19, 1983—a remarkable achievement considering the traffic maintenance requirements and that one-half of the work was done during winter weather conditions. The contractor achieved an average replacement of 1,554 ft<sup>2</sup> per calendar day and 2,745 ft<sup>2</sup> per workday. This project was accomplished while being restricted to night work only, with the requirement of maintaining two lanes of traffic during the work effort.

### Transversely Posttensioned Double-Tee Beams

In many states (e.g., Colorado, New Mexico, and Wyoming), prestressed double-tee beams have been used for rural and secondary roads. However, this structural system is aimed at state and Interstate class highway bridges with spans measuring up to 80 ft (24.4 m) in length. The prestressed prefabricated beams are transported to the construction site and erected adjacent to each other (Figure 32). Next, the beams are tied together transversely by a simple joint and transverse posttensioning. The joints are then filled with a high-strength nonshrink grout and the transverse posttensioning is applied to provide lateral load transfer. Generally, the bridge is designed with an allowance for a deck overlay to improve rideability. However, in Florida, no deck overlay is used.

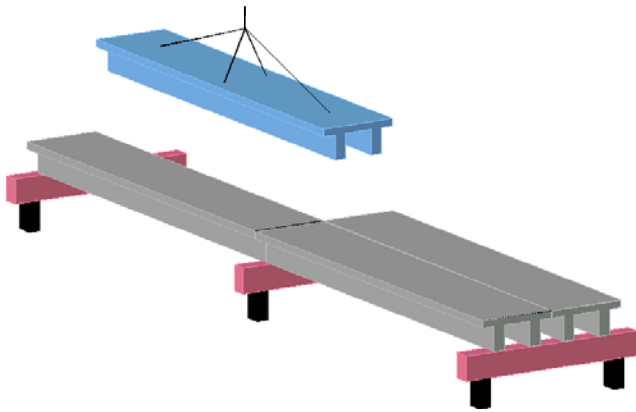

FIGURE 32 Double-tee bridge system.

The elimination of cast-in-place elements is associated with speed of construction and reduction in labor costs. The first two bridges (Gains Street and Texas Street) were built in the city of Tallahassee, Florida, after an extensive research study sponsored by the Florida DOT (24). As shown in Figure 33, only a crane and two skilled workers are needed to erect the bridge superstructure. All initial studies indicate that this system is very economical and cost-effective for short- and medium-span bridges [up to 65 ft (19.8 m)] (24,25). For spans ranging from 65 to 80 ft (19.8 to 24.4 m), transportation and erection constraints may prevail. The level of transverse posttensioning is an important parameter to ensure a monolithic behavior of the bridge deck. Shahawy reported that a minimum uniform compression of 250 psi across the longitudinal joints is required to develop monolithic behavior (24).

### Prefabricated Abutment

The use of a prefabricated abutment system based on prefabricated counterfort (ribbed) wall sections anchored to footings using tensioned bars or tendons was reported by



FIGURE 33 Construction of transversely posttensioned double-tees bridges.

Scanlon et al. (26). Variations in abutment-wall and wing wall configurations made it difficult to develop standardized elements. It was decided, therefore, to use cast-in-place footings as a base for the prefabricated counterfort elements.

Figure 34 shows an 8-ft-high abutment front wall and the two-lift wingwall in place. Segments are typically 16 ft long with two stems per segment. Posttensioning tendons are placed at the front and back of the stems to tie the abutment unit to the cast-in-place footing. Dowels from the footing are connected to the tendons by couplers near the base of the prefabricated unit.

No bracing is required during installation, owing to the stable configuration of the prefabricated unit. Abutment units are limited to 8 ft in height for ease of transportation. For higher walls, two or more lifts can be used, as demonstrated in the wingwall arrangement. The use of prefabricated abutment elements requires that loads be transmitted across horizontal joints. This can be accomplished by either match casting or grouted joints. At the interface of the cast-in-place footings and the prefabricated units a grouted



FIGURE 34 View of counterfort abutment system for a single-span bridge over Miller's Run Creek in southwestern Pennsylvania. [Source: Scanlon et al. (26).]

joint is necessary. Match casting was considered for joints between the prefabricated units; however, on the basis of input from industry representatives, the research team decided that a grouted joint would be preferable.

A demonstration project based on the design concepts as described was developed for a bridge replacement project in Pennsylvania DOT District 11-0, Allegheny County, on SR-3026 over Miller's Run Creek. A key element contributing to the success of the project was the accurate installation of the dowels embedded in the footing to be connected to the posttensioning rods in the abutment walls. Figure 35 shows the front and back dowels projecting from the cast-in-place footing. The vertical anchors were stressed after both the footings and grout joints attained a minimum compressive strength of 3,000 psi. The prefabricated bridge seat at the west abutment was set on the prefabricated abutment segments and posttensioned simultaneously.



FIGURE 35 Cast-in-place footings with projecting dowels. [Source: Scanlon et al. (26).]

To avoid the use of compacting equipment between the counterfort stems, a fluid fill was used. Figure 36 shows a

view of the backside of the abutment with fill placed close to the top of the bridge's beam seat.



FIGURE 36 Fluid backfill behind abutment. [Source: Scanlon et al. (26).]

It was estimated that the use of prefabricated abutment units allowed the bridge to be opened approximately 2 weeks earlier than would have been possible if a standard cast-in-place abutment system had been used.

### Prefabricated Piers and Caps

The substructure often consumes 60% to 70% of the time required to construct a bridge (27). Significant reductions in the time required to construct a bridge may be achieved by using prefabricated elements in the substructure. This section of the chapter focuses on improving bridge substructures by developing attractive and rapidly constructed substructure systems for short- and moderate-span bridges. The importance of the improved substructure design is discussed. A specific proposal for a prefabricated segmental substructure system is described including methods of fabrication and erection (21).

The Ferguson Structural Engineering Laboratory at the University of Texas at Austin conducted a research project through the Center for Transportation Research, with the goal of improving the efficiency, appearance, and durability and reducing the time required for the construction of short- and moderate-span bridge systems. The TxDOT and the FHWA sponsored this project. One of the outcomes of the study was a proposed segmental prefabricated concrete substructure system for standard highway bridges.

### *Proposed Prefabricated Segmental Substructure System for Standardization*

The substructure system must be developed with forms and details that can easily be standardized. By enabling wide

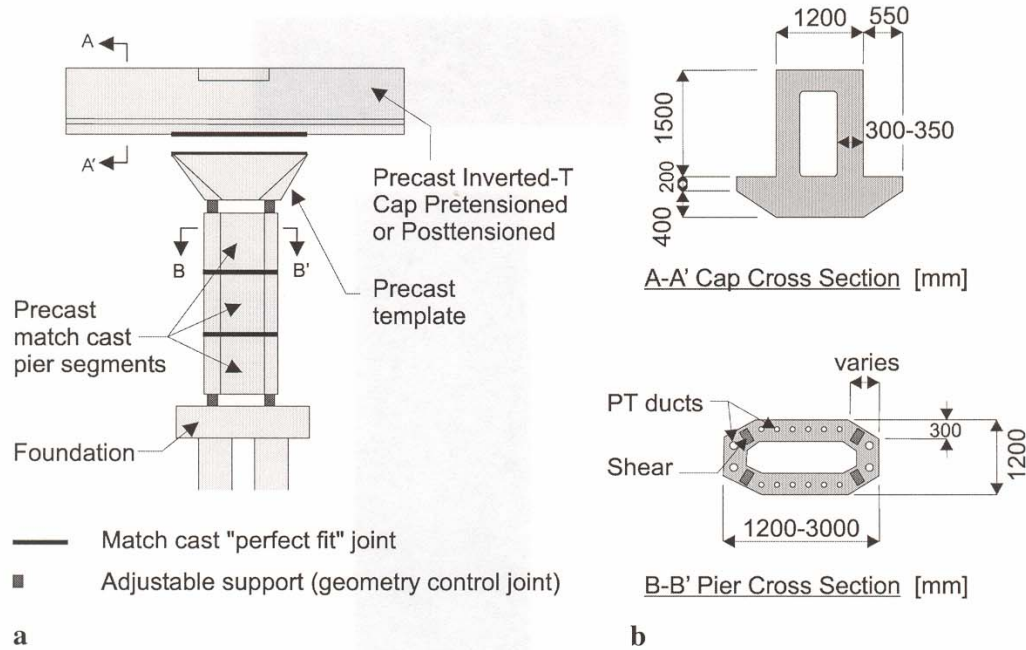

FIGURE 37 (a) Segmental pier system; (b) match-cast column segment, precast temple segment, inverted-T cap match cast, cap and pier cross sections. [Source: Billington et al. (21).]

reuse, standardization will bring costs down over time, and it can make a prefabricated substructure system economically competitive with cast-in-place substructure systems for many bridge projects. Also, a prefabricated system should make use of existing prefabricated plant facilities and equipment. The construction equipment, predominantly cranes, required for substructure erection should be compatible with the equipment requirements for the erection of the superstructure. The economics of a design should consider not only the initial dollar costs, but also the indirect costs and benefits to the public associated with the reduction in construction time and impact at the site.

The prefabricated substructure system proposed in 2001 is made up of three basic segment types: match-cast column segments, a “template” segment, and an inverted-T cap match cast to the template (Figure 37a) (21). Inverted-T caps are proposed to improve visibility through the bridge, as well as increase the clearance underneath the substructure. Details are developed for the inverted-T caps supporting simply supported girders without provision of continuity.

Four column sizes were designed to produce varying bent configurations (Figure 37b). The pier segments are hollow, high-performance concrete segments with a wall thickness of 13.8 in. (350 mm) to accommodate inserts in the formwork for exterior relief or texture. Hollow sections keep the weight of the elements low for hauling and erection. The walls of the hollow pier segments provide enough room for the posttensioning bars, as well as for the multi-

strand tendons. The hollow pier segments also provide room for internal drainage ducts.

The proposed system has been designed to produce a wide range of straight and skewed substructure units, including single-column, straddle, and frame bents (Figure 38). The bents can support roadways up to 105 ft (32 m) wide and up to 59 ft (18 m) high. All bent caps can be fabricated in single elements up to 42.7 ft (13 m) long. All single-column bents are constructed with only one cap segment. Cap segments may be pretensioned or posttensioned. Straddle and frame bents each consist of two piers with two caps joined by a cast-in-place joint and continuous longitudinal posttensioning. These wider bents can accommodate caps up to 88.6 ft (27 m) in length with only two cap segments.

Four template segment sizes were designed, each corresponding to one of the four pier segments. The template segment is basically a construction aid. The template is used as the central base of the form for match casting the pier cap. During erection, the light template piece can be quickly aligned and cast into place on top of the pier. The larger and heavier cap segment that had previously been match cast to the template is then easily placed on and posttensioned down to the prefabricated pier. The erection time is greatly reduced and the geometry control is improved by having the prefabricated cap match cast to a template. Construction speed and efficiency are further improved with a prefabricated system when the cap can be prefabricated and handled as one segment. To obtain a sys-

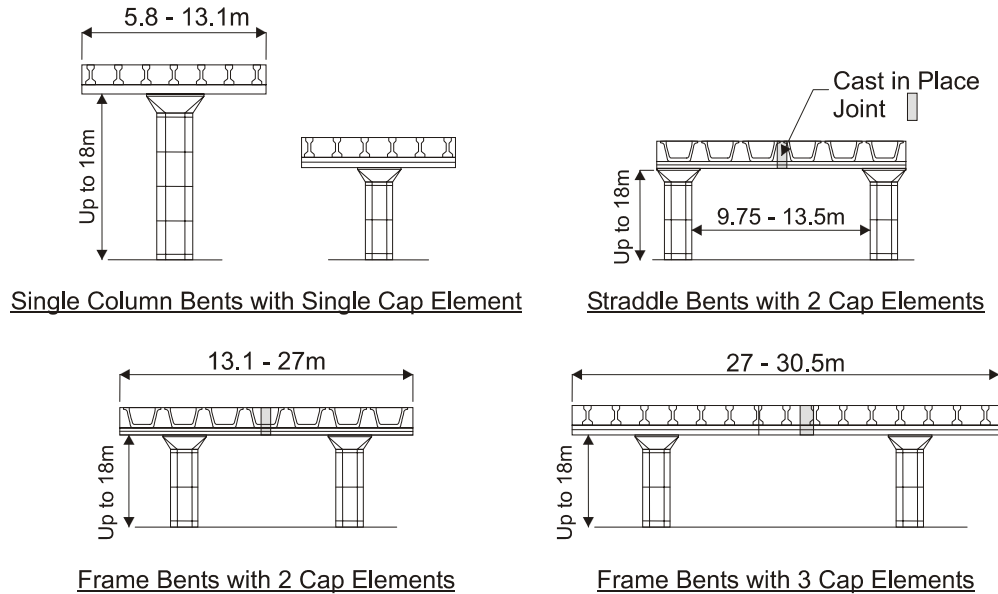

FIGURE 38 Different proposed bent types. [Source: Billington et al. (21).]

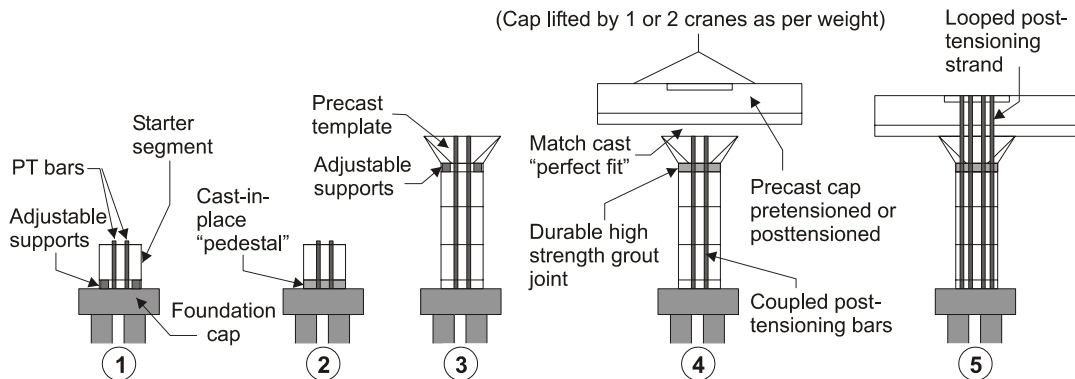

FIGURE 39 Erection sequence for a single-column bent. [Source: Billington et al. (21).]

tem whereby the cap could be one single prefabricated element up to 43 ft (13 m) in length, the standard inverted-T cap section was modified by removing the nonstructural material (Figure 38) (28).

#### Fabrication and Erection

The erection sequence for a single-column bent is shown in Figure 39. The first column segment is placed and aligned on adjustable supports on a previously cast footing. Post-tensioning ducts are spliced, internal drainpipes are placed, and joint reinforcement is tied. This first segment is then locked into position with a cast-in-place high-quality concrete joint. With the first segment set, the next pier segments can be lowered into place. Posttensioning bars are coupled, and epoxy is placed on the faces of adjoining

segments. The segment is then lowered into position and posttensioned. The match-cast joints with aligning shear keys allow rapid placement. No further field alignment changes are needed.

With the final pier segment in position, the template segment is then placed. The template is set on adjustable supports, then the ducts are spliced, and the segment is aligned to provide the proper cross slope for the match-cast cap. The small joint [3 to 4 in. (75 to 100 mm)] is then filled with a high-strength epoxy grout. Next, the template segment is posttensioned down to the pier and the cap is then placed. Epoxy is applied between the cap and the template immediately before setting the cap into position.

Pier erection of frame bents is the same as that for the single-column bents. After the piers are constructed,

match-cast cap segments are set on their templates and posttensioned to the piers. Any additional segments required between the cap segments would be added in a manner similar to that done for balanced cantilever construction. The remaining joint between the segments is then cast and the entire cap is posttensioned.

#### *Edison Bridge Replacement*

The Edison Bridge, named after Thomas A. Edison, carries US-41 over the Caloosahatchee River in Fort Myers, Florida. The original structure, 4,623 ft long, was built in 1931 and replaced with dual structures in 1991. The new structures consist of continuous posttensioned bulb-tee girder superstructure spans with a cast-in-place deck, prestressed concrete piling foundations, cast-in-place pier caps, and prefabricated reinforced concrete pier columns and caps (Figure 40). The structure was designed to accommodate vessel impact loading in accordance with the AASHTO *Guide Specification and Commentary for Vessel Collisions: Design of Highway Bridges* (29).



FIGURE 40 View of prefabricated substructure and girders of Edison Bridge.

One of the most unique aspects of the new structures is that the substructure above the footings is entirely prefabricated. All columns and cap beams are prefabricated in one piece and weigh up to 90 tons (Figure 41). The prefabricated elements are connected with a unique bar-splicing

system. With prefabrication of the substructure, the erection of the columns and caps was completed quickly and contributed substantially to the early completion of the project. The construction for both bridges—9,850 ft of structure—was completed in 25 months (*The Edison Bridge*, special brochure, 1992).



FIGURE 41 Installation of prefabricated bent cap in Edison Bridge.

#### **INNOVATIVE PREFABRICATED SYSTEMS AND ELEMENTS: INTERNATIONAL EXPERIENCE**

A limited number of publications were found on the use of prefabricated systems as common practice in the bridge construction industry. The redecking of Jacques-Cartier Bridge in Montreal, Canada, presents an interesting example of using the prefabricated systems to minimize traffic disruption (Figure 42). The Jacques-Cartier Bridge is a five-lane bridge, 11,236 ft or 2 1/6 mi (3.4 km) in length, spanning the St. Lawrence River between the cities of Montreal and Longueuil. Approximately 43 million vehicles cross the bridge every year.

During two construction seasons in 2001 and 2002, the 71-year-old Jacques-Cartier Bridge underwent complete redecking of the five-lane-wide, 2.7-km-long bridge deck. The new deck is constructed of prefabricated, prestressed, and posttensioned panels (Figure 43) made of high-performance concrete that were prefabricated at a temporary plant installed near the south end of the bridge. Exactly 1,680 prefabricated deck units, representing a surface area of about 667,000 ft<sup>2</sup> (62,000 m<sup>2</sup>) were installed principally during nighttime from April to October during 2001 and 2002. The new prestressed concrete deck panels were posttensioned transversally and longitudinally to control water infiltrations, through construction joints made of rapidly setting mortar. The entire project was completed without disturbing normal peak hour traffic.



FIGURE 42 Jacques-Cartier Bridge. (Source: [www.pjcci.ca](http://www.pjcci.ca).)



FIGURE 43 Prefabricated deck panel. (Source: [www.pjcci.ca](http://www.pjcci.ca).)

Case studies about large bridge projects using the segmental construction method have been reported. The case of the Nesenbachtalbruecke Bridge in Germany is presented as an innovative composite bridge (30). The bridge consists of a welded box girder and high-tensile fine-grained steel connected with steel tubes, which support transverse steel girders at a distance of approximately 13 ft 4 in. (4 m). These transverse girders support 4.8-in. (120-mm)-thick prefabricated concrete slabs, which will be completed at a later time with in situ concrete to a total thickness of 16 in. (400 mm). The composite action is secured by stirrups. This innovative system requires neither falsework nor formwork. Also, the use of prestressed prefabricated concrete for parts of bridges has been reported in Germany with very positive results (31).

Large bridge projects have used prefabrication to accelerate construction. The case of the A13 Viaduct in the United Kingdom is an example. This project used 1,030 prefabricated prestressed glued segmental units, giving a 5,833-ft (1750-m)-long continuous structure to provide a low-maintenance structure with minimum joints and bearings (32).

In Japan, a new method for the construction of bridge piers using prefabricated prestressed concrete panels as formwork was proposed to increase the efficiency of construction (33). Experiments were carried out on six different reinforced concrete column specimens. These experiments were performed to check whether the panels acted as an integral part of the structure with a good bond between panels and core concrete. It was observed that the use of the prefabricated prestressed panels did not create any weakness in the structural behavior of the specimen and can be used effectively for the construction of bridge piers.

#### USE OF FIBER-REINFORCED POLYMERS FOR PREFABRICATED SYSTEMS AND ELEMENTS

FRP composite materials have shown potential as alternative bridge construction materials compared with conventional ones. The acceptance of composites in the highway bridge industry is primarily because of their high strength, low density, better durability, and corrosion resistance when compared with steel and concrete. Moreover, FRP materials lend themselves to prefabrication and mass production; they are easily formed into structural shapes, transported, and erected. In recent years, innovative systems of prefabricated FRP decks were developed and some pilot projects were constructed; some of them are continuously being monitored to obtain maximum performance information.

#### Prefabricated Superstructures

##### *Advanced Composite Deck Panels*

FRP panels offer lightweight, superior corrosion resistance, and ease of erection. Several systems, most of which are composed of conventionally pultruded triangular or tube sections with a deck, bottom plates, and polymer concrete riding surfaces, are under evaluation at this time. Among the issues being investigated in the development of these



FIGURE 44 FRP deck panels made in a tongue and groove design for easier installation.

structures are environmental ones other than corrosion, connections for the members and the supporting beams, and the attachment of crashworthy barriers. An example of an FRP deck replacement is shown in Figure 44.

#### FRP Decks

FRP decks have been used recently in pilot projects and are still being monitored to evaluate their behavior under service. For them to become as popular as conventional decks, standardized construction procedures, quality control and quality assurance criteria, and standardized

(ASTM) tests for FRP materials and details need to be implemented. The experience and knowledge gained from the construction of four bridges in West Virginia and Pennsylvania and many other FRP bridges built in the United States can be used to develop future FRP deck construction standards. Also, the ongoing monitoring of these bridges will validate the long-term performance of FRP decks.

The installation time for FRP bridge decks is very brief compared with that for conventional decks. For example, the erection time of an FRP composite deck is about one-eighth to one-tenth of that necessary for a conventional concrete deck. The construction crew required for FRP decks is also smaller than that for conventional decks. The experience of four FRP bridges in West Virginia showed that a typical construction crew of six people (without any special training) needed 1 day to install the FRP deck modules for a bridge of about 500 ft<sup>2</sup> (46 m<sup>2</sup>) like that of Wickwire Run Bridge. However, on a large job such as the Market Street Bridge, a 10,800 ft<sup>2</sup> (1003 m<sup>2</sup>) deck was installed by a crew of five people working 6 h a day, for 6 days, with an additional 200 h needed to provide glass fabric reinforcement over field joints (34).

A number of projects have been completed or are under way. Table 4 cites FRP pilot bridge projects that have been executed in the United States up to 2001. Table 5 lists the FRP composite decks installed in Ohio under Project 100, and Table 6 records the FRP composite decks being installed in Ohio in 2002 and 2003 under the Composites

TABLE 4  
COMPLETED BRIDGE PROJECTS UP TO 2001

Bridge	Location	Description	Completion Date
Test panels	Univ. of California, San Diego	Steel girders, polymer concrete wear surface	1996
All-composite bridge	Idaho Falls, Idaho	Composite girders, asphalt wear surface	1997
Tech 21 all-composite bridge	Butler County, Ohio	Composite girders, asphalt wear surface	1997
Darke County	Ohio	Steel girders, micro silica-modified concrete wear surface	1999
Warrensburg	New York	Steel girders, polymer concrete surface	2000
Riverside County	California	Carbon tube girders, polymer concrete wear surface	2000
Six Ohio bridges	Ohio		2001

TABLE 5  
FRP COMPOSITE DECKS INSTALLED IN OHIO UNDER PROJECT 100

Bridge Name	Owner	Dimensions	Total (ft <sup>2</sup> )	Manufacturer	Completion Date
Westbrook Road	Montgomery Co.	34'3" × 32'8"	1,119	Hardcore	April 2000
Elliot Run	Knox Co.	38'10" × 25'6"	975	Hardcore	July 2000
Sintz Road over Rock Run	Clark Co.	62' × 30'	1,860	Hardcore	Nov. 2000
Five Mile Road Bridge #0171	Hamilton Co.	44' × 28'	1,232	Hardcore	Nov. 2000
Five Mile Road Bridge #0087	Hamilton Co.	47' × 30'	1,410	Hardcore	May 2001
Spaulding Road	Montgomery Co.	83'1" × 56'	4,653	Hardcore	May 2001
Hebble Creek	Wright Patterson AFB	32' × 17'2"	544	Comptek/Webcore	July 2001
Five Mile Road Bridge #0071	Hamilton Co.	43' × 30'	1,290	Hardcore	Aug. 2001
Shaffer Road	Ashtabula Co.	175' × 17'	2,975	Hardcore	Oct. 2001

TABLE 6  
FRP COMPOSITE DECKS BEING INSTALLED IN OHIO IN 2002 AND 2003

Bridge Name	Owner	Dimensions	Total (ft <sup>2</sup> )	Manufacturer	Completion Date
Fairgrounds Road Bridge	Greene Co.	221' × 31'7.66"	6,851	Martin Marietta Composites	April 2002
Hudson Road/Wolf Creek Bridge	Summit Co.	117' × 33'8", 7.66' deep	3,938	Martin Marietta Composites	TBD
Hotchkiss Road Bridge	Geauga Co.	65' × 28'5" deep	1,820	Martin Marietta Composites	2003
Cats Creek Bridge	Washington Co.	80'4.5" × 24'5" deep	1,929	Martin Marietta Composites	October 2002
Hales Branch Road Bridge	Clinton Co.	65'6" × 24'5" deep	1,572	Martin Marietta Composites	2003
County Line Road over Tiffin River	Defiance Co.	186.5' × 28'7.66" deep	5,222	Martin Marietta Composites	2003

Notes: The Composites FOR Infrastructure (C4I) effort is administered by the National Composite Center. TBD = to be determined.

FOR Infrastructure (C4I) effort administered by the National Composite Center (<http://epoint1.iserver.net/ncc/infrastr1.php>, previously named [www.compositecenter.org](http://www.compositecenter.org)).

*FRP Modular Decks for Highway Bridges*

A bridge deck is generally defined as a structural element that transfers loads transversally to supports such as longitudinal girders, cross beams, or stringers that bear on the bridge's abutments. Two types of FRP deck bridges are commercially available, the sandwich and pultruded shapes (35). Sandwich construction (Figure 45) implies the use of strong, stiff face sheets that carry flexural loads, and a low-density, bonded core material that separates the face sheets and ensures composite action of the deck. Because of the ease with which face sheets and core materials can be changed in manufacturing, sandwich construction provides great flexibility in designing for varied depths and deflection requirements. Face sheets of sandwich bridge decks are primarily composed of E-glass mats and/or roving, infused with a polyester or vinylester resin. Current core materials are rigid foams or thin-walled cellular FRP materials such as those shown in Figure 45. Changes in details related to materials, orientations, and thickness of the FRP face sheets or core can be determined analytically.

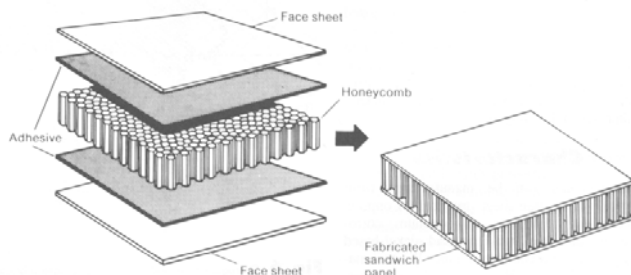

FIGURE 45 Sandwich construction.

The most currently available commercial decks are constructed using assemblies of adhesive-bonded pultruded shapes. Such shapes can be economically produced in continuous lengths by numerous manufacturers, with the use of well-established processing methods. Design flexibility in this type of deck is obtained by changing the constituents of the shapes (such as fiber type and fiber orientation) and, to a lesser extent, by changing the cross section of the shapes. Because of the potentially high cost, variations in the cross section of shapes are feasible only if sufficiently high production warrants the equipment investments. Although systematic methods of optimizing pultruded shapes have been developed, optimized deck designs are largely derived by trial and error. Several examples of decks with pultruded shapes are shown in Figure 46.

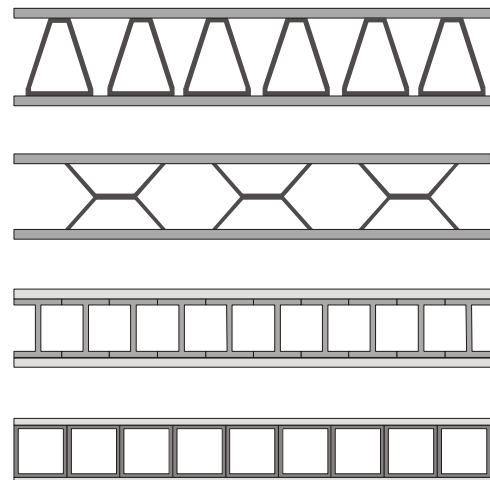

FIGURE 46 FRP decks produced from adhesive-bonded pultruded shapes.

*FRP Decks Supported by Steel or FRP Stringers*

Pultruded shapes have been used as modular decks supported on steel stringers for highway bridges. The Con-

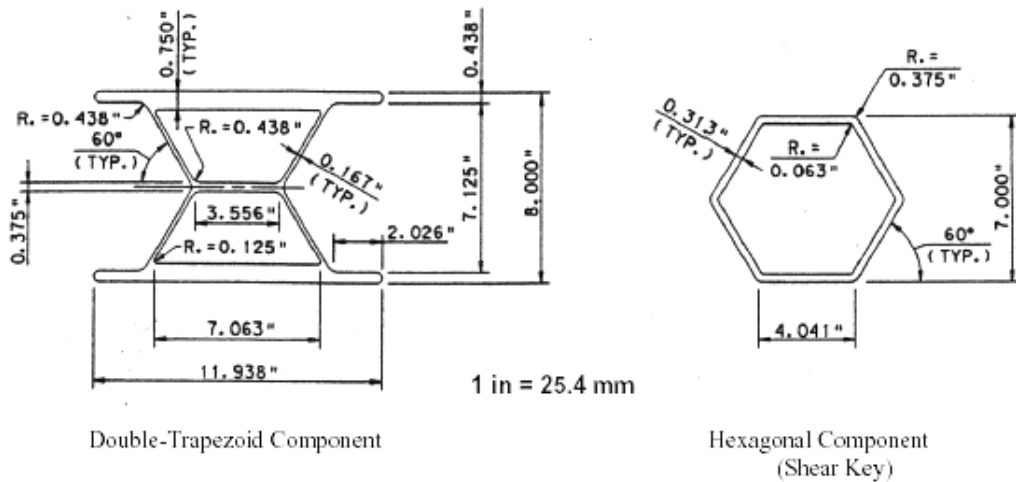

FIGURE 47 Cross section of composite bridge deck. [Source: Shekar et al. (34).]

structed Facilities Center of West Virginia University, in cooperation with the FHWA and West Virginia DOT—Division of Highways, has been involved in rehabilitation (either replacement or strengthening) of approximately 20 bridges using FRP composite materials (34). The implementation of FRP modular decks on four bridges was adopted. The FRP deck was about 20% of the weight of a typical reinforced concrete deck. The cross section was made of a hexagon and double trapezoids, as shown in Figure 47. The fiber architecture consisted of E-glass multiaxial stitched fabrics with chopped strands and continuous roving. The matrix was made of vinylester resin, which has good weatherability and good resistance to harsh environments. The construction of the four bridges is detailed here to discuss the different aspects related to FRP bridges (34).

The double trapezoid and hexagonal components were assembled at the manufacturing plant under controlled conditions using a two-part polyurethane adhesive between the individual components to form a deck module. The deck modules were available in standard 8-ft (2.43-m) widths along the bridge span direction with variable lengths equal to the required bridge width. The thickness of the deck modules was maintained at 8 in. (203 mm). The FRP deck modules were transported to the bridge site without any special permit, because the modules were either 7 or 8 ft (2.13 m or 2.43 m) wide and their length was equal to the bridge width, which was less than 29 ft (8.8 m).

Before the deck modules were connected to the stringers, the surfaces of the composite deck modules and the stringers, over which the deck was to be seated, were prepared—that is, sandblasted to remove grease and dirt. The FRP composite deck was placed transversally to the span direction (flow of traffic) and was supported by longitudinal steel stringers (FRP stringers for Laurel Lick Bridge,

West Virginia) (Figure 48). The FRP composite deck modules were joined in the field using shear keys that provide mechanical interlocking and an adhesive-bonded surface. The sequence of assembly of the FRP deck modules on the steel or FRP stringers was the same as for each of the four composite deck bridges. Once the first deck module was placed on the stringers and bonded and bolted with Huck bolts (Figure 48), the subsequent deck module was placed next to the first module and the two modules were “squeezed” together to establish a good bond and full shear transfer with the remaining modules.



FIGURE 48 Placement of FRP deck modules over FRP stringers (Laurel Lick Bridge). [Source: Shekar et al. (34).]

For the Laurel Lick, Laurel Run, and Wickwire Run bridges, the deck was connected to the stringers, using both adhesive bonding and mechanical fasteners. Before the application of the adhesive, the bottom of a deck module was drilled and the module was placed on the predrilled locations of the top flanges of the stringers. To ensure a good bond between the deck and a stringer, a primer adhesive

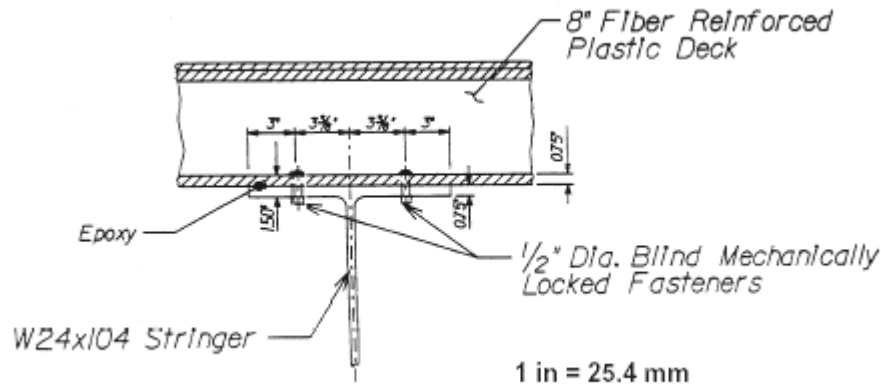

FIGURE 49 Deck to stringer connection using BOM blind bolts. [Source: Shekar et al. (34).]

was first applied on the top surface of the sandblasted stringer. The adhesive was also applied to the bottom flange of the deck surface and on the expansion dams. The first deck module was aligned with the stringers and was placed in position with the use of lifting hooks. A hydraulic jack was used to push the deck module against the expansion dam. The deck was then connected to the stringers using BOM blind bolts, as shown in Figure 49.

For the Laurel Lick, Laurel Run, and Wickwire Run bridges, the FRP deck modules were interconnected using both adhesive bonding and mechanical fasteners. The adhesive was applied to the tongue and groove joints of the first module before the adjacent module was bonded to it. In addition to the adhesive bonding, mechanical fasteners (blind bolts) were provided in the shear keys for adequate transfer of shear between the modules. In the Market Street Bridge, the modules were interconnected by adhesive bonding only. The modules were held together with a special device (using the wrench mechanism) after applying the adhesive and positioning the modules properly on the steel girders (Figures 50 and 51).

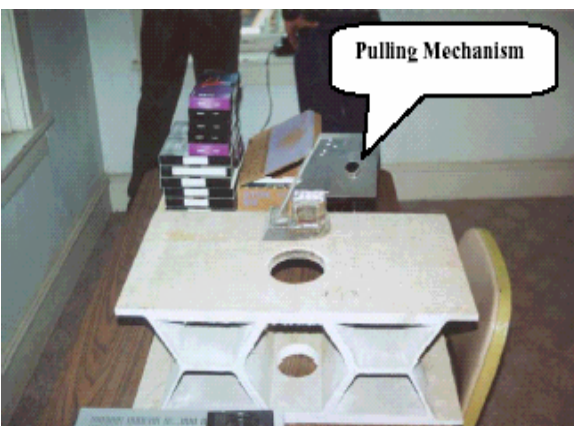

FIGURE 50 Special pulling mechanism. [Source: Shekar et al. (34).]



FIGURE 51 Pulling mechanism of modules. [Source: Shekar et al. (34).]

The open edges of the FRP decks for the Laurel Lick, Laurel Run, and Wickwire bridges were closed with pultruded FRP angles to prevent moisture from entering into the deck cells. In the case of the Market Street Bridge, instead of FRP angles, a pultruded channel section was used at the edges of the FRP deck, and it was bonded to the deck with an adhesive.

#### *Permanent FRP Deck Forms*

The proposed innovative construction technologies should improve on current construction practices. One proposed technology is to simplify the concrete reinforcement assembly process and therefore speed up construction. The pultruded SIP FRP deck form and the pultruded grid panels will be prefabricated and presized units delivered to the job site. The deck forms will be rapidly placed without the need of time-intensive falsework or formwork, which is usually needed in conventional concrete deck pours. The system proposed by Dieter et al. (36) will be used in the following sections to explain and describe the permanent FRP deck forms.

The proposed FRP-reinforced concrete system is made up of two layers, one top and one bottom (see Figure 50 for a picture of a FRP system mock-up). The bottom tensile reinforcement consists of a pultruded SIP FRP deck form (Figure 52) spanning between, but not continuously over, the girders. The FRP deck form is analogous to the main positive steel reinforcement typically placed perpendicular to the girder system. Each deck form is 18 in. (457.2 mm) wide and overlaps with adjacent deck forms by means of a shiplap joint. The SIP forms are stiffened by two 3-in. (76.2-mm) hollow square corrugations centered 9 in. (228.6 mm) apart. To ensure composite action through horizontal shear transfer between the deck form and the concrete, 0.25-in. (6.35-mm) aggregate is bonded with epoxy to most of the horizontal surface area of the deck.

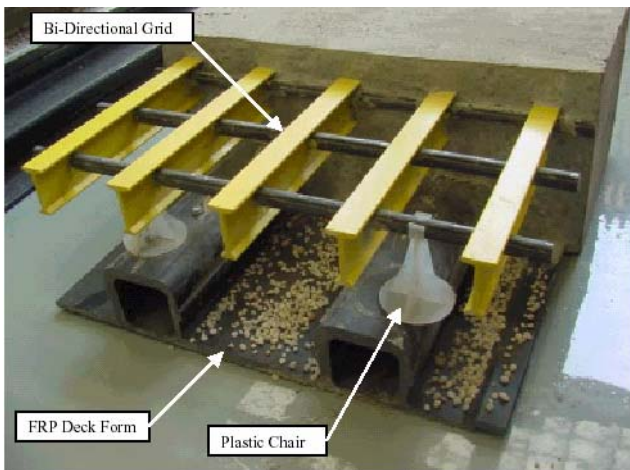

FIGURE 52 Mock-up of FRP reinforcement system. [Source: Dieter et al. (36).]

The bottom reinforcement layer contains no longitudinal reinforcement, which would be analogous to the distribution reinforcement typically seen in a traditional steel-reinforced deck. However, the actual bridge deck design will contain FRP reinforcement bars for negative moment continuity reinforcement over the middle pier. Beyond the negative moment envelope, a percentage of the FRP reinforcement bars will continue to the abutments. A bidirectional FRP grid panel provides the top transverse and the top longitudinal (direction with respect to the girders) tensile reinforcement. The transverse reinforcement for negative moment over the girder is provided by I-shaped FRP bars. The longitudinal reinforcement, commonly referred to as temperature and shrinkage reinforcement, is supplied by oval FRP bars (dark bars in Figure 52). The oval FRP bar stays in the plane of the I bars by penetrating through and mechanically locking with the I bar web. The orthogonal members of the grid are spaced at 4 in. (101.6 mm) on center in each direction. Both bars are quite smooth and cannot develop adequate bond to the concrete. However, because they lie within the same plane and are inherently connected, they mechanically anchor one another.

## Prefabricated Substructures

### FRP Composite Piles

There are considerable problems associated with the use of traditional piling materials in corrosive soils and marine environments. The durability of concrete, corrosion of steel, and vulnerability of timber piles to marine borers are serious hindrances to construction in these environments. Composite materials, such as FRP, offer performance advantages over steel, concrete, or timber. These advantages include corrosion resistance, high-oriented-strength structural shapes, durability, and low maintenance. The main polymers currently in use in plastic piling include fiberglass high-density polyethylene combined with stabilizers and fiberglass reinforcement. The products available in the market can be classified into the following types:

- *Steel pipe core piling*—Steel core piling, the first product in the American market, consists of a recycled plastic shell encasing a steel pipe core. The steel pipe core provides all of the structural strength. In 1997, the piles were available in 8 to 24-in. (20 to 60-cm)-outer diameter and up to 75 ft (23 m) long (37). The structural pipe cores ranged from 4 to 16-in. (10 to 40-cm)-outer diameter, with wall thickness ranging from 0.237 to 1.594 in. (6 to 40 mm). The product is guaranteed for a period of 5 years against shrinkage and expansion cracking—problems encountered in the earlier version of the product.
- *Structurally reinforced plastic matrix*—These piles typically consist of recycled plastic matrix reinforced with fiberglass or steel rods. Typically, the plastic matrix is chemically treated with antioxidants and ultraviolet inhibitors to retard the effects of ultraviolet light on the plastic. Such piles are currently used by naval facilities for fender applications, and they are being pilot tested for bearing loads of up to 10 tons (37).
- *Fiberglass pipe pile*—Fiberglass pipe piles typically consist of an acrylic-coated fiberglass tubular section. The fiberglass (glass and vinylester) shell provides structural strength, and the acrylic coating protects the pile against abrasion, ultraviolet light, and chemical attacks. These piles are typically filled with concrete after installation to improve their structural performance, or they are filled with concrete and cured before driving (37).
- *FRP*—FRP piling consists of a recycled plastic matrix with randomly distributed fiberglass reinforcement in the matrix. The available product consists of 20% glass fiber-reinforced, high-density, extruded recycled polyethylene with an outer solid section and a foam center (38–41).

### International Experience in Using FRP

An innovative application of FRP in new bridge construction occurred in the 1990s in Europe and Japan (42). In the United Kingdom, an innovative modular-glass, reinforced-polyester pultruded construction system has been developed, called ACCS (advanced composite construction system). It enables bridges to be built by bonding together simple cellular components using epoxy adhesives. The components incorporate a keyway, which enables components to be connected quickly and accurately. The system was installed when it had competed successfully with traditional solutions. Some bridges using FRP materials have been constructed in the last decade, examples of which are briefly described here.

#### *West Mill Bridge, Oxfordshire, England*

The first vehicular bridge in Western Europe constructed with composite deck was open to traffic on October 2002 in Oxfordshire, England (43). Below the deck is a composite support structure consisting of four pultruded glass and polyester box beams that are spaced 6.5 ft (2 m) apart and attached to concrete abutments (Figure 52). The deck structure is bonded to the box beams with epoxy. The wear surface is a polymer concrete and epoxy material. The bridge weighs approximately 41 tons, one-third of which is the weight of the composite materials. The light weight of the deck enabled the use of a mobile 200-ton crane, which lifted the deck into position in under 30 min.

#### *Aberfeldy Footbridge, Scotland*

The previously mentioned new footbridge joining two halves of a municipal golf course over the Tay River at Aberfeldy was built entirely from composite materials. The main span of 210 ft (64 m) consists of GFRP deck with GFRP towers. The stay cables consist of Aramid fiber parallel-lay ropes.

#### *Bond's Mill Lifting Bridge, England*

This lifting bridge providing access over a canal to an industrial estate in Stonehouse, Gloucestershire, can carry full U.K. highway loading with vehicular weights of up to 38 tons. The light weight of the GFRP structure allows simple hydraulic machinery to be used to lift the structure. Savings in machinery and foundations made the total cost competitive.

#### *A19 Viaduct, Middlesbrough, Cleveland, England*

The A19 Viaduct over the Tees River in Cleveland consists of steel plate girders and a composite deck, the underside of which has been completely enclosed with a GFRP structure to protect the primary structure from the elements, and from which further maintenance can be carried out.

#### *Pedestrian Bridge, Switzerland*

Switzerland, a pioneer country in FRP use for construction strengthening and rehabilitation, built the first GFRP pedestrian bridge in Pontresina in 1997 (44). The bridge has two spans of 41 ft 8 in. (12.5 m) and a width of 5 ft (1.5 m). The bridge was constructed in 1 week by 25 architecture students. The bridge was then tested under a load of 5 kN/m<sup>2</sup>.

#### *Pedestrian Test Bridge, Japan*

In Japan, a full-scale pedestrian test bridge was built in the Public Works Research Institute in Tsukuba (45). This bridge is a three-span continuous cable-stayed structure that is 65.5 ft (20 m) long, with an effective central span of 36 ft (11 m) and a deck width of 6.5 ft (2 m). The axial deck slab beams are fabricated by pultruded GFRP hollow panel members placed side by side, and then the cross girders suspended from the stay cables support the axial deck beams. Carbon FRP cables were used as stay cables. The bridge was designed to support a live load of 3.43 kN/m<sup>2</sup>.

## PRESENTATION AND ANALYSIS OF THE SURVEY

This chapter discusses the survey questionnaire addressed to the state and provincial DOTs, which was devised to evaluate the practices in the states and provinces on the use of innovative prefabricated systems and elements for bridge construction, rehabilitation, and replacement. This chapter also analyzes the questionnaire responses.

### SCOPE AND OBJECTIVES OF THE SURVEY QUESTIONNAIRE

The use of innovative prefabricated systems and elements in bridge design and construction can limit traffic disruption and improve workzone safety. The survey questionnaire solicited information on the use of such systems and elements in new bridge construction, and in the rehabilitation and replacement of commonly used bridges. A “system” is defined as a combination of prefabricated elements (concrete, steel, or any advanced materials) that eliminates, or considerably limits, cast-in-place concrete. The use of prefabricated elements, such as pier caps, columns, full-depth decks, etc., can effectively minimize construction time, traffic disruption, and the impact of construction activities on the environment. Elements in this context exclude common ones, such as typical beams. Information on new construction techniques and innovative use of materials that have not been fully implemented was also solicited.

### FEATURES OF THE SURVEY QUESTIONNAIRE

The complete survey questionnaire is presented in Appendix A. It states the problem, outlines the scope and the objectives of the survey, and provides the contact’s address. The body of the survey consists of 16 questions, which can be divided into 4 series, covering 4 areas of interests. The first series of questions attempts to identify the type and the frequency of use of prefabricated systems and elements for bridge construction, rehabilitation, or replacement to accelerate construction time and to have a minimum impact on traffic and the environment. It also aims to identify the reasons for using such innovative prefabricated systems and elements. The second series addresses the locations of the prefabrication plants, their distances to the bridge sites, and the means used to transport the prefabricated systems and elements to the sites. The third series is concerned with the cost of the systems and elements when compared with alternative solutions in first costs, life-cycle costs, mainte-

nance and removal, and lane closure time. The last series of questions addresses successful pilot projects and incentive contracts that may accelerate bridge construction, rehabilitation, or replacement.

### EVOLUTION OF PREFABRICATED SYSTEMS AND ELEMENTS

A nationwide questionnaire was used in 1984 to evaluate the use of prefabricated elements and systems in bridges (27). The 36 agency responses covered a total of 229,000 bridges. Approximately 35,000 of the bridges covered in the survey (15%) had prefabricated elements. Prestressed I-beams, prefabricated concrete slabs, prefabricated box beams, steel SIP forms, partial- and full-depth prestressed subdeck panels, double-tees and channels, and prefabricated parapets were the most popular prefabricated elements according to responses to that survey. In addition, the responses indicated that only about 1,200 bridges (0.5%) contained completely prefabricated superstructures. They also revealed that only eight bridges contained full-depth prefabricated concrete deck panels, and less than 0.1% had prefabricated substructures. The present survey aims to identify the extent of prefabrication used in bridge construction, rehabilitation, or replacement. Emphasis was placed on innovative systems in which the systems are prefabricated and then transferred and assembled in place, thereby limiting construction delay and traffic disruption in the case of rehabilitation or replacement. Construction materials and prefabricated components of bridges that significantly accelerate the construction were included. Typical prefabricated elements such as beams and piles were excluded; only the quasi-totally prefabricated superstructure and substructure were targeted.

The present survey received 23 responses from 19 U.S. DOTs and 4 Canadian provinces. From these, 18 responses were usable; the remaining responses were determined to be unusable owing to the lack of information. Note that a response did not necessarily include an answer to each of the 16 questions. Table 7 shows the states and provinces that completed the survey questionnaire and the percentage of answered questions. Table 8 lists the number of answers for each of the main aspects of the survey discussed in this chapter.

Although the questionnaire reflects an emphasis on innovative bridges, such as full-depth deck panels, completely

TABLE 7  
STATES AND PROVINCES THAT COMPLETED THE QUESTIONNAIRE

State/Province	No. of Answered Questions	Percentage of Answered Questions
Texas	16	100
Virginia	13	81
New Mexico	13	81
Tennessee	11	69
Pennsylvania	11	69
New Hampshire	11	69
Connecticut	10	63
Illinois	9	56
Minnesota	9	56
Iowa	7	44
Ohio	6	38
Kansas	5	31
Georgia	5	31
Wisconsin	2	13
Alberta	9	56
Nova Scotia	14	89
Saskatchewan	13	81
Quebec	11	69

TABLE 8  
NUMBER OF ANSWERS FOR EACH OF THE MAIN ASPECTS OF THE SURVEY

Question	No. of Useful Answers	Related Aspect of Survey	Related Figures
2	14	Reason for use	56
3	17	Prefabricated systems	53
3	13	Innovative systems for rehabilitation or new construction	55, 57, and 62
5	12	Distance	58
6	12	Means of transportation	59
8	13	Roads	54
12	11	Aspects needing development	61
13	16	Portions suited to prefabrication	60

prefabricated superstructures or substructures, and FRP deck bridges, it also covers conventionally prefabricated bridge elements and systems that lead to significantly reduced construction time. Steel deck forms, partial-depth deck panels, and transversely posttensioned boxes eliminate formwork and therefore are good examples of such conventional systems. Figure 53 shows the distribution of these bridges, according to survey responses. It can be observed that innovative bridges present a small percentage (2%) of the total bridges constructed, from the perspective of minimum construction delay. However, responses indicated that the states do plan to use such innovative bridges in the future, particularly in the cases of rehabilitation and replacement of bridges with a high volume of traffic. The partial-depth deck panels were mainly reported in Texas and Tennessee, whereas the permanent steel form was reported in Tennessee only.

Prefabricated bridge systems are used on all types of roads, from Interstate roads to secondary roads, as indicated in Figure 54. However, the majority of these bridges (53%) are used on Interstate and primary roads with high traffic volume (i.e., more than 10,000 daily vehicles).

Figure 55 presents the geographical distribution of prefabricated bridges and covers in only those states that responded to the survey questionnaire. As indicated in the figure, innovative prefabricated bridges are concentrated in Texas (21%), Virginia (19%), and Tennessee (13%). States having less than 2% of such bridges were omitted from the reported distribution. However, as mentioned in chapter two, pilot projects using FRP materials have been constructed in Ohio, and more are being planned for future construction (see Tables 3–5 based on information from the website: [www.compositecenter.org](http://www.compositecenter.org)).

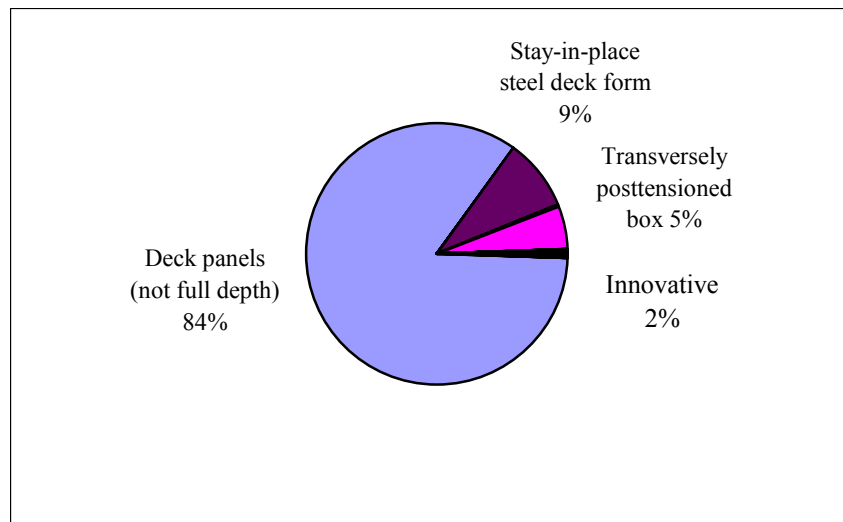

FIGURE 53 Distribution of conventional and innovative bridges.

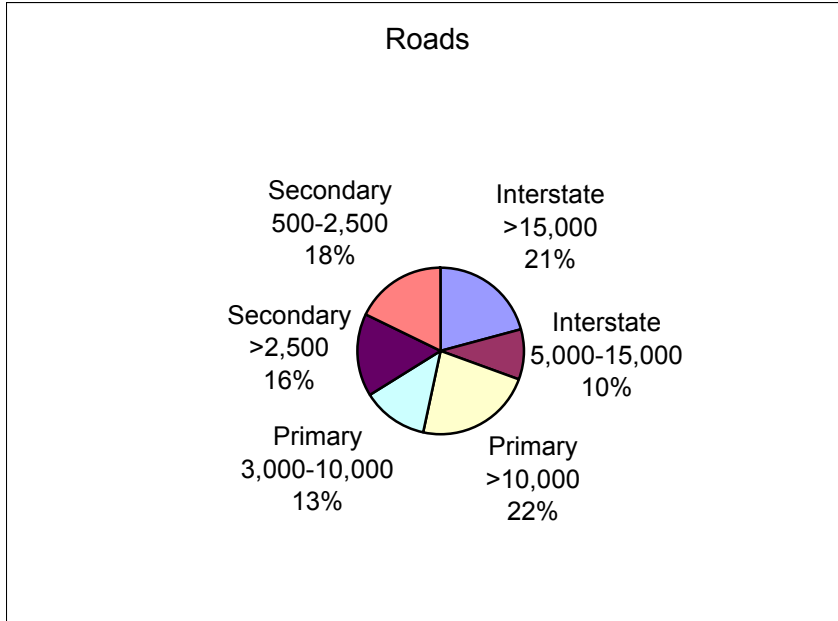

FIGURE 54 Distribution of prefabricated bridge system on roads.

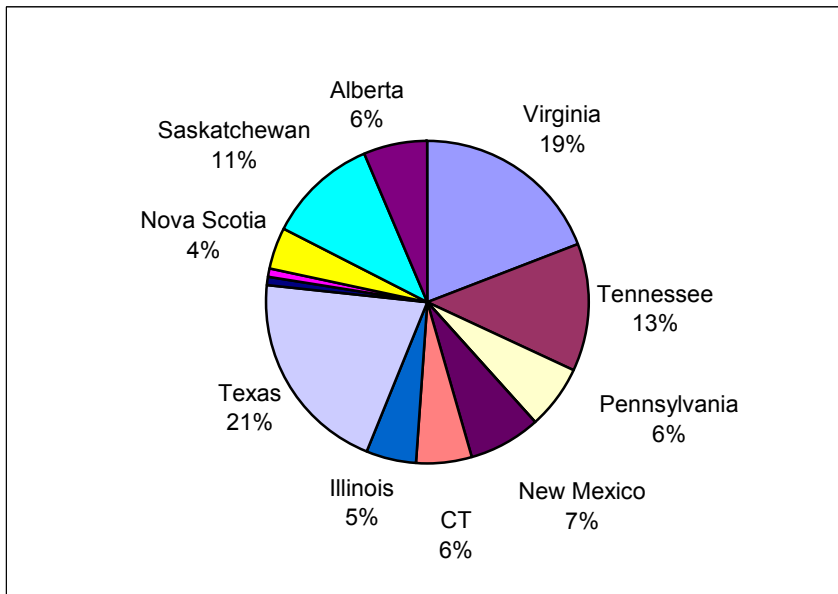

FIGURE 55 Distribution of innovative bridges among states.

**USE OF PREFABRICATED SYSTEMS IN NEW BRIDGE CONSTRUCTION, REHABILITATION, AND REPLACEMENT**

The major reasons for using prefabricated systems, according to survey respondents, are presented in Figure 56 and include to facilitate construction (28%), to minimize construction delay (22%), and to minimize lane closure time (17%). Other reasons were to improve quality and durability, to increase safety, and to minimize environmental impact and costs.

The analysis of these responses shows that the bridges were mainly developed to overcome construction difficulties and to minimize the lane closure time. This is evident, because approximately two-thirds (63%) of these systems were used in rehabilitation or replacement of bridges in the United States alone (Figure 57). This finding also explains why cost may become a secondary criterion for selecting the bridge construction method and materials. Figure 57 excludes bridges with partial-depth deck panels, transversally posttensioned boxes, and SIP steel forms. Instead, it

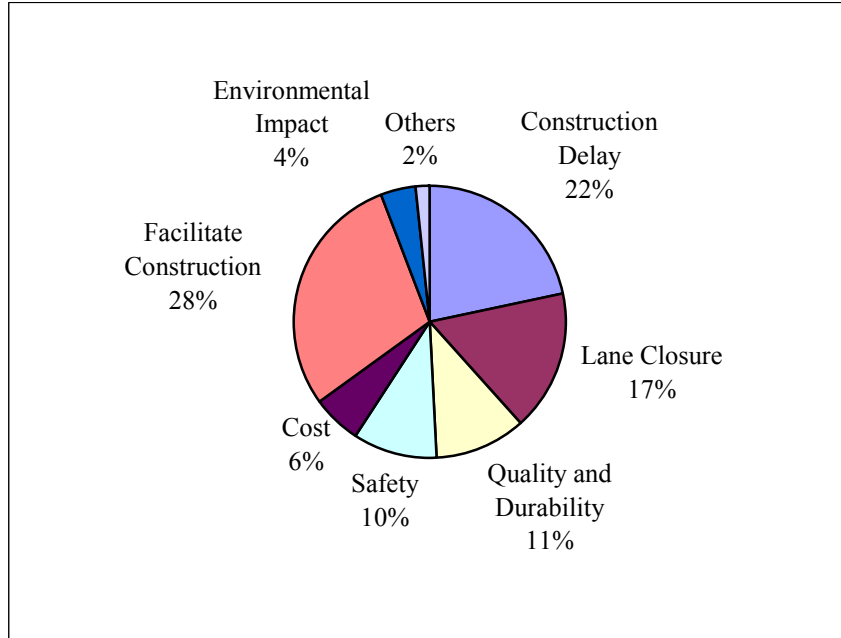

FIGURE 56 Reasons for using innovative prefabricated bridges.

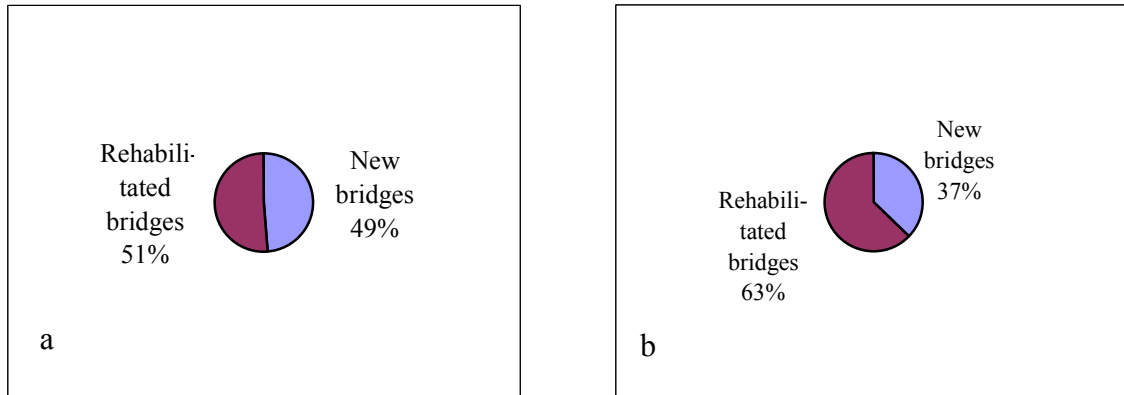

FIGURE 57 Use of innovative prefabricated bridges in rehabilitation and new construction: (a) United States plus Canada; (b) United States only.

focuses on innovative bridges recently developed and used as pilot projects, on quasi-totally prefabricated bridges, or on bridges using advanced composite materials.

It should be mentioned that although environmental impact was commonly given by the survey respondents as a reason for using prefabricated bridges, it remains of a secondary order (Figure 56). This result can be partially explained because these systems are generally used in special conditions, such as in urban centers or on highway roads where traffic lane closures and the economic consequences predominantly govern the choice. Nevertheless, the interest in environmental impact when choosing a bridge construction method is clearly indicated.

**FABRICATION AND TRANSPORTATION OF PREFABRICATED BRIDGE UNITS**

One major advantage of using prefabricated bridges is to limit work at the bridge site, which minimizes traffic disruption, minimizes environmental impact, increases safety, and enhances the quality of construction under controlled conditions. Prefabrication proceeds in an established, repetitive, and systematic manner regardless of bad weather. Furthermore, high-quality concrete can more easily be obtained. That is, the allowable tolerance is achieved by a systematic supervision of the fabrication process and by using precise forms. The survey responses did not reveal any problems related to the tolerance in the fabrication and

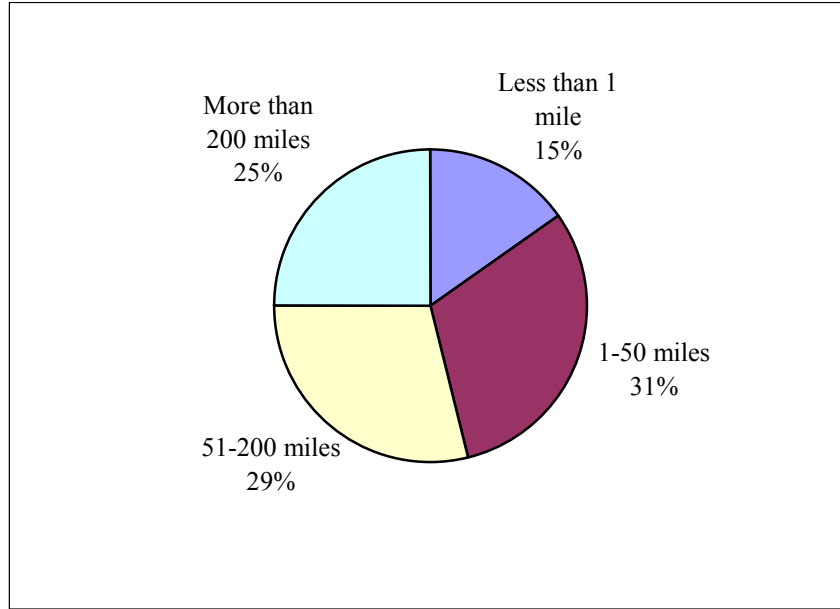

FIGURE 58 Distance between prefabrication plant and bridge site.

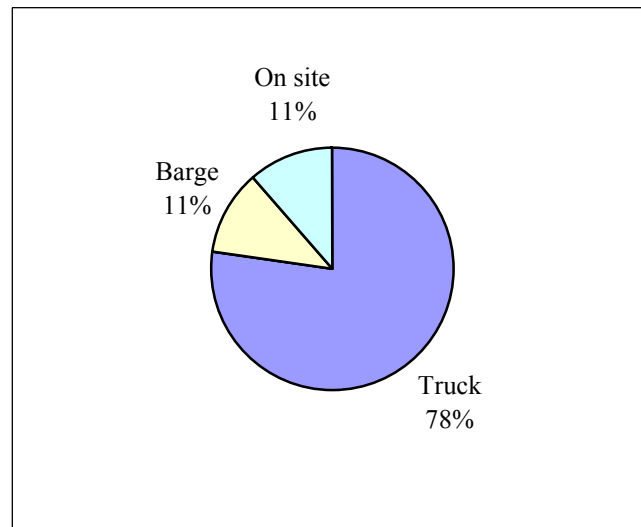

FIGURE 59 Means of transportation of prefabricated elements.

the assembly of the prefabricated elements that make up the innovative bridge systems. This can be explained because the emphasis was placed on prefabrication systems, which include the assembly process and the connections as an integral part of the system design.

As shown in Figure 58, the distance between the fabrication plant and the bridge site is generally more than 50 mi (54%). Approximately one-third (31%) of the bridges are prefabricated at a distance of between 1 and 50 mi from the bridge site. A limited number of bridges (15%) are prefabricated on-site or less than 1 mi from the bridge site.

The majority of these bridges are fabricated at temporary plants next to the bridge site, as can be deduced from Figure 59, where it is indicated that 11% of bridges are fabricated on-site and did not need any special means of transportation.

The survey responses revealed that the large majority of prefabricated elements of the different innovative systems were transported to the bridge site by trucks (78%), as shown in Figure 59. Only 11% of the cases used barges to transport the prefabricated elements. Some bridges were prefabricated next to the bridge site and were assembled on-site; hence, transportation was not required. Rail was a

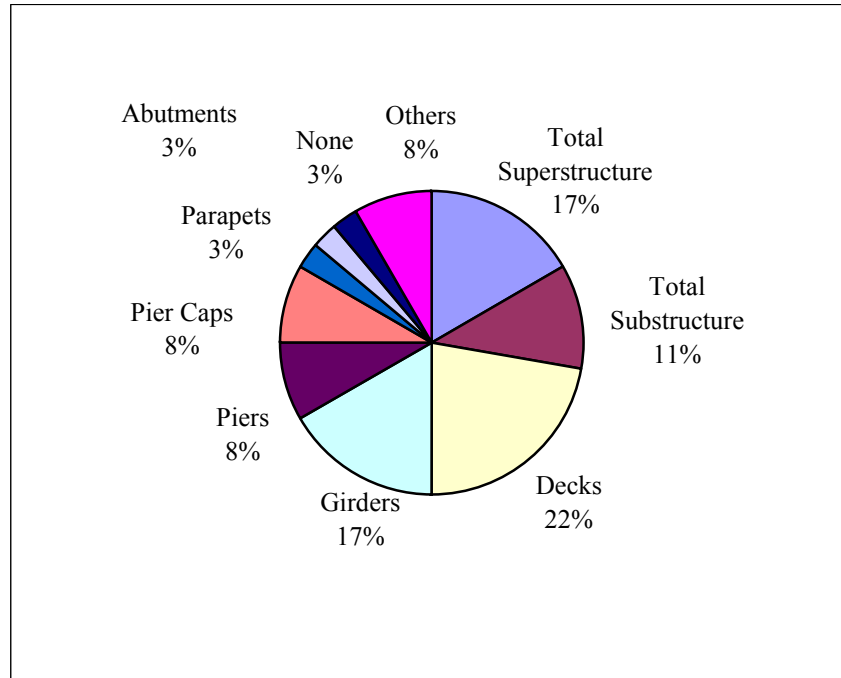

FIGURE 60 Most suitable component of a bridge for prefabrication.

possible means of transportation, but it was not reported in this survey (27). The development of the prefabrication process and of elaborate systems allowed these systems to be made of elements with dimensions and weights easily transportable by truck. Therefore, the survey responses did not reveal any problems related to transportation.

#### PREFABRICATION SUITABILITY AND NEED FOR DEVELOPMENT

The literature review showed that the prefabrication process has been developed to cover both superstructure and substructure components of bridges. The survey results confirmed this extent of prefabrication use for all parts of bridges (Figure 60). However, responses revealed that the deck still remains the portion of a bridge that is most suitable for prefabrication (22%). Some responses were more detailed and cited precise parts of the superstructure, such as girders (17%). Of the responses, 59% and 30%, respectively, qualified the superstructure and the substructure as the most suitable for prefabrication. One possible explanation for this observation is the repeatability and the mass production possible of the superstructure compared with that of the substructure. Another explanation lies in the improvement in the quality of construction and the cost-effectiveness related to the superstructure of a bridge—thanks to the experience gained in that area and the level of standardization achieved in superstructure prefabrication.

Figure 61 shows the relative importance of other aspects in the bridge prefabrication industry that require further

development. Concerns raised among the survey respondents are related to the initial cost (22%), design and standardization (22%), experience of contractors (21%), and connections (18%). Despite the great effort that has been dedicated to the development of connections and standardization in the field, old connection problems are still not fully solved. Clearly, there is an urgent need for sustained research and development efforts in these aspects. Furthermore, initial cost presents a continuing disadvantage of the prefabricated systems (22%), compared with that of conventional methods. The high initial cost of these prefabricated systems is related to the lack of standardization and because these systems are innovative and imply new expensive materials and specialized equipment. However, the introduction of the life-cycle cost attenuates the effect of the initial cost inconvenience.

The problem of durability seems to be of lesser importance, because it is mentioned in only 8% of the survey responses. Also, the problems related to the weight and length of elements has become less important, owing to the development of better-performing installation equipment.

#### EFFECTIVENESS OF PREFABRICATED SYSTEMS AND ELEMENTS

The prefabricated systems most used, according to the survey respondents, are presented in Figure 62. It can be observed that prefabricated caps are used in 16% of the surveyed prefabricated bridges included in the survey,

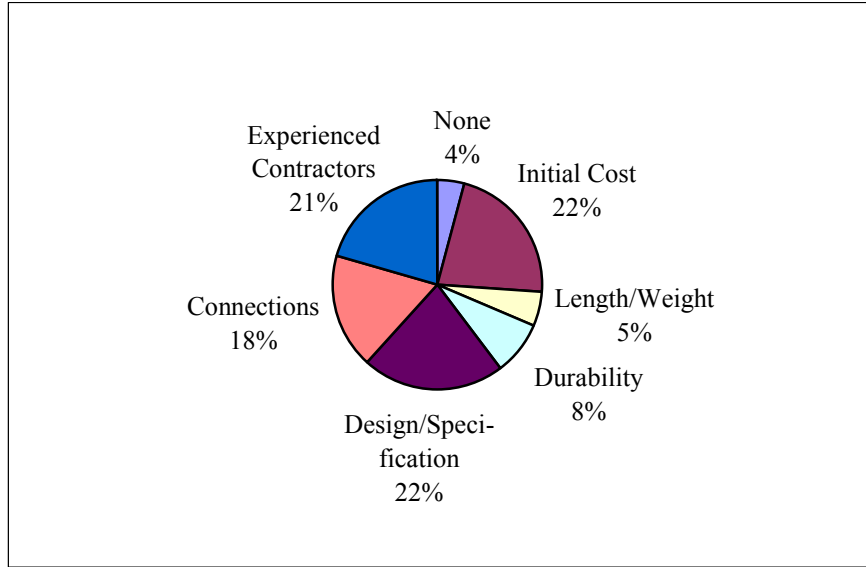

FIGURE 61 Aspects in bridge prefabrication requiring further development.

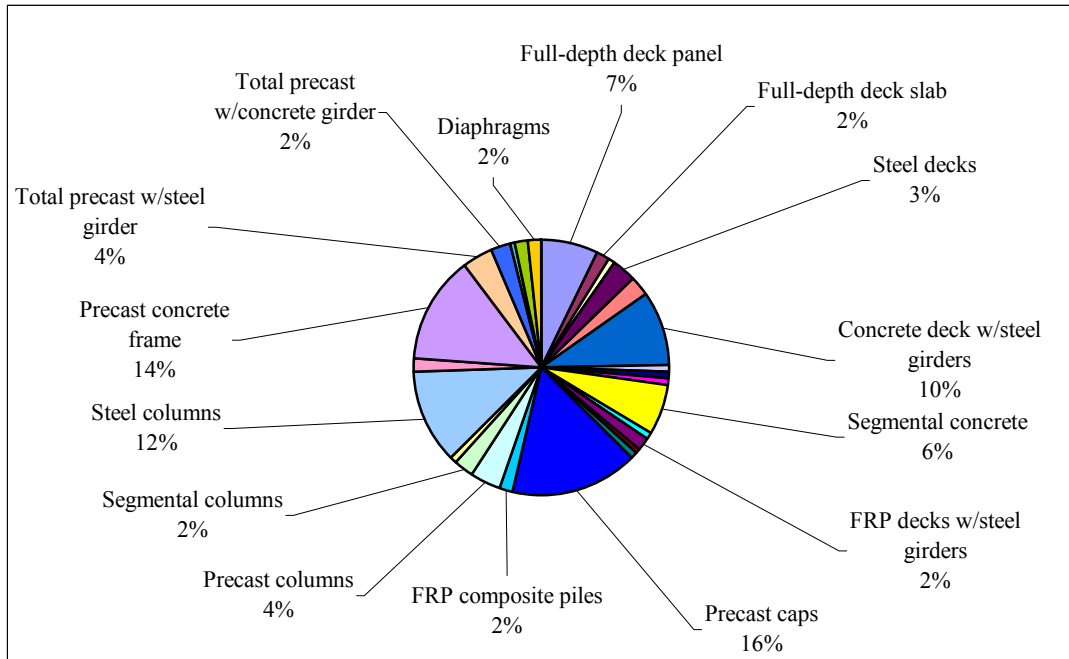

FIGURE 62 Distribution of the most used innovative bridge systems.

followed by prefabricated concrete frame systems (14%); steel columns (12%); concrete bridge decks with steelgirders (10%); full-depth, prefabricated, prestressed concrete deck panels (7%); and segmental concrete bridges (6%). Other systems, such as totally prefabricated superstructure/substructure bridges, steel decks, FRP decks, prefabricated columns, segmental columns, and FRP composite piles represent 2% to 5% of the surveyed bridges. Some pilot projects, less than 2% of bridges, are not reported in the figure. The effectiveness of these systems is discussed here

in terms of the following aspects: traffic disruption, quality assurance, ease of construction, costs, and environmental impact.

**Traffic Disruption**

The results of the survey showed that the main reason for the use of prefabricated systems is to minimize construction delay and lane closure time, and hence, to minimize traffic disruption. The new orientation toward the devel-

opment of totally prefabricated systems contributes to improving the performance of the prefabrication industry, with regard to minimizing traffic disruption. Thus, negative economic consequences for nearby commercial activities and the disturbance for motorists (including time wasted and fuel costs) are significantly reduced. Examples presented in chapter two with regard to this aspect showed the possibility of replacing a bridge or building a new bridge within a few days instead of months.

### **Quality Assurance**

The quality of prefabricated bridges is found to have improved with the increasing use of advanced materials and high technologies. The repeatability and the automation of the prefabrication industry in controllable conditions contribute to improving the quality and precision of prefabricated segments. This was apparent from the survey responses, because the increase in quality and durability were indicated as reasons for the use of prefabricated bridge systems. Also, durability was less emphasized in the survey responses when respondents were asked about the aspects that need more attention and more development in bridge prefabrication.

### **Ease of Construction**

The survey responses revealed that the first reason for the use of prefabricated systems is to facilitate construction. Safety improvement at the bridge site was also reported as a reason. The high-precision technologies used in the fabrication of units facilitate assembly and reduce construction delay.

Installation was also facilitated by the use of better-performing equipment and the use of lightweight materials.

### **Costs**

Initial cost is still seen as a disadvantage for implementing innovative prefabricated systems. Few responses pertained to initial and life-cycle costs. These responses indicated that the initial cost of prefabricated bridges is generally equal to or greater than those of alternative solutions. However, the survey responses revealed that if practitioners take into account the life-cycle cost, in addition to the savings from reduced lane closure time, prefabricated systems may become an economical solution, as indicated in the literature review (chapter two).

### **Environmental Impact**

The survey responses showed that the environmental impact is greatly reduced with the use of prefabricated systems, owing to the shorter construction period. Respondents indicated that environmental considerations are a specific reason for choosing prefabrication in 4% of the cases. This small percentage is not reflected in the information collected, in which the environmental aspect is often used as a major argument for the adoption of prefabricated systems. That the focus of the survey was on innovative prefabricated bridge systems may explain this low percentage, because such systems are relatively few and are often used to solve a local, specific problem. Therefore, in this context, environmental impact remains a secondary reason for using prefabricated systems.

## CONCLUSIONS

This synthesis report has presented the findings of an investigation on the use of innovative prefabricated elements and systems to limit traffic disruption during the construction, rehabilitation, widening, or replacement of bridges. This chapter summarizes the conclusions reached, presenting findings from the literature review, as well as conclusions drawn from the survey.

From the literature review, the following observations were made:

- New systems have been developed to prefabricate bridge decks, superstructures, and substructures. The new orientation is toward the development of totally prefabricated systems that minimize traffic disruption.
- Prefabricated elements are manufactured at the factory or near the job site under tight quality control. Controlling the various aspects of manufacturing can enhance durability in comparison with cast-in-place elements.
- Initial cost and lack of standardization were reported as the main disadvantages for prefabricated systems. This lack of standardization most often results in a higher construction cost. However, the initial higher cost may be justified by the enhanced durability, briefer construction time, and longer life cycle of the systems.
- Fiber-reinforced polymer bridges are gaining in popularity. However, many questions related to long-term performance, durability, standard specifications, and cost remain unanswered. An increasing use of fiber-reinforced polymer materials was reported. Pilot bridge projects were constructed and are being monitored to better understand their long-term behavior.

From the survey responses, the following conclusions were drawn:

- Respondents gave three major reasons for using innovative prefabricated systems: (1) faster construction, (2) minimizing construction delay, and (3) minimizing lane closure time. Each of these principal reasons can lead to minimizing traffic disruption.
- The survey responses confirmed that prefabrication is done for all parts of bridges. However, the superstructure remains the bridge component most suitable for prefabrication. Approximately two-thirds of the

prefabricated systems were used in rehabilitation or replacement of bridges.

- There is a general agreement that prefabricated bridges may have higher quality than those with cast-in-place construction. This quality may be further enhanced through the use of new advanced materials.
- Improved safety at the bridge site was also reported as a reason for using prefabrication.
- The problems of weight and length of elements appear to be less important, owing to the development of better-performing erection equipment.
- Generally, the distance between the fabrication plant and the bridge site is more than 50 mi. The majority (78%) of prefabricated units are transported by trucks.
- According to the survey responses, aspects of the bridge prefabrication industry still requiring development include connections, design, standardization, and contractor experience.
- Initial cost was often cited as a disadvantage for prefabricated systems, when compared with the cost of conventional methods. However, the survey responses in some cases revealed that the initial cost was equal to or less than that of alternative solutions.

Overall, the use of prefabricated elements and systems is increasing. However, this increase is concentrated in a limited number of states that appear to have easier access to new technologies and innovative systems. The major problems that inhibit the widespread use of innovative systems and elements were identified as follows: initial cost, lack of standardization, lack of specialized contractors, and problems with connections. Nevertheless, the advantages of prefabricated systems in the reduction of lane closure time and low maintenance costs increase the competition of these systems compared with conventional solutions. To overcome the problems raised in the survey responses, research should be undertaken to develop more reliable connecting devices, standard sections, and better-performing materials.

Finally, emphasis should be placed on efficient communication and collaboration between departments of transportation, engineering consultants, researchers, and contractors to share concerns, orient research projects, and generalize the successful aspects, which could lead to standardization and the design of guidelines for practicing engineers.

## REFERENCES

1. Babaei, K., A. Fouladgar, and R.T. Nicholson, "Nighttime Bridge Deck Replacement with Full Depth Prefabricated Concrete Panels at Route 7 over Route 50, Fairfax County," Presented at the 80th Annual Meeting of the Transportation Research Board, Washington, D.C., 2001.
2. Clarke, J.L., "The Use of Fiber Composites in Concrete Bridges—A State of the Art Review," *Technical Guide No. 3*, Concrete Bridge Development Group, Crowthorne, Berkshire, England, 2000.
3. Head, P.R., "Advanced Composites in Civil Engineering: A Critical Overview at This High Interest, Low Usage Stage of Development" (M. El-Badry, ed.), *Advanced Composite Materials in Bridges and Structures*, Canadian Society of Civil Engineering, Montreal, Quebec, Canada, 1996, pp. 1–15.
4. Johansen, G.E., et al., "Spanning 'Devils Pool' with a Prestressed Cable/FRP Tube Structural System" (K. Neale and P. Labossiere, eds.), *Advanced Composite Materials in Bridges and Structures*, Canadian Society for Civil Engineering, Montreal, Quebec, Canada, 1992, pp. 15–30.
5. Roper, N.J., Virginia Department of Transportation, 2002 [Online]. Available: [http://www.aashtotig.org/focus\\_technologies/prefab\\_elements/elements.stm](http://www.aashtotig.org/focus_technologies/prefab_elements/elements.stm).
6. Domagalski, T., Illinois Department of Transportation [Online]. Available: [http://www.aashtotig.org/focus\\_technologies/prefab\\_elements/elements.stm](http://www.aashtotig.org/focus_technologies/prefab_elements/elements.stm).
7. McKeel, W.T., Jr., "Bridge Maintenance and Management: A Look to the Future," A3C06: Committee on Structures Maintenance and Management, Transportation Research Board, National Research Council, Washington, D.C., 2002.
8. Thruway Authority Public Affairs Office, New York Department of Transportation, Administrative Headquarters [Online]. Available: [http://www.aashtotig.org/focus\\_technologies/prefab\\_elements/elements.stm](http://www.aashtotig.org/focus_technologies/prefab_elements/elements.stm).
9. Zaki, A. and M. Lachemi, "Innovative Use of Prefabricated Concrete Integrated Deck Systems for Bridges," *Bridge Engineering Conference 2000* (A. Hady Hosny, ed.), Sharam El-Sheikh, Egypt, 2000, pp. 365–375.
10. Zaki, A., "Du Chene River Railway Bridge," *PCI Journal*, Vol. 34, No. 5, 1989, pp. 110–117.
11. Utley C.R., Lubbock District Engineer, Texas Department of Transportation, 2003 [Online]. Available: [http://www.aashtotig.org/focus\\_technologies/prefab\\_elements/elements.stm](http://www.aashtotig.org/focus_technologies/prefab_elements/elements.stm).
12. Elgaaly, H., Federal Lands Bridge Office, Federal Highway Administration, 2003 [Online]. Available: [http://www.aashtotig.org/focus\\_technologies/prefab\\_elements/elements.stm](http://www.aashtotig.org/focus_technologies/prefab_elements/elements.stm).
13. Khanna, O.S., A.A. Mufti, and B. Bakht, "Experimental Investigation of the Role of Reinforcement in Concrete Deck Slabs," *Canadian Journal of Civil Engineering*, Vol. 27, No. 3, 2000, pp. 475–480.
14. Mufti, A.A., B. Bakht, and J.P. Newhook, "Experimental Investigation of Prefabricated Composite FRP Deck Slabs," *Canadian Society for Civil Engineering 2002—30th Annual Conference*, Montreal, Quebec, Canada, 2002.
15. Clendenin, G., Virginia Department of Transportation [Online]. Available: [http://www.aashtotig.org/focus\\_technologies/prefab\\_elements/elements.stm](http://www.aashtotig.org/focus_technologies/prefab_elements/elements.stm).
16. Kukreja, D.N., Virginia Department of Transportation [Online]. Available: [http://www.aashtotig.org/focus\\_technologies/prefab\\_elements/elements.stm](http://www.aashtotig.org/focus_technologies/prefab_elements/elements.stm).
17. Christian, G.A., New York State Department of Transportation, 2003 [Online]. Available: [http://www.aashtotig.org/focus\\_technologies/prefab\\_elements/elements.stm](http://www.aashtotig.org/focus_technologies/prefab_elements/elements.stm) 2003.
18. Freeby, G., Bridge Division, Texas Department of Transportation, 2003 [Online]. Available: [http://www.aashtotig.org/focus\\_technologies/prefab\\_elements/elements.stm](http://www.aashtotig.org/focus_technologies/prefab_elements/elements.stm).
19. Berkenbile, K., STOA/Carlos + Law, 2003 [Online]. Available: [http://www.aashtotig.org/focus\\_technologies/prefab\\_elements/elements.stm](http://www.aashtotig.org/focus_technologies/prefab_elements/elements.stm).
20. Ralls, M.L., Bridge Division, Texas Department of Transportation [Online]. Available: [http://www.aashtotig.org/focus\\_technologies/prefab\\_elements/elements.stm](http://www.aashtotig.org/focus_technologies/prefab_elements/elements.stm).
21. Billington, S.L., R.W. Barnes, and J.E. Breen, "Alternate Substructure Systems for Standard Highway Bridges," *Journal of Bridge Engineering*, Vol. 6, No. 2, 2001, pp. 87–94.
22. American Association of State Highway and Transportation Officials [Online]. Available: [http://www.aashtotig.org/focus\\_technologies/prefab\\_elements/elements.stm](http://www.aashtotig.org/focus_technologies/prefab_elements/elements.stm).
23. Nickerson, R.L. and J.B. Policelli, "Woodrow Wilson Bridge Deck Replacement Slide Narrative," FHWA Office of Structures, Baltimore, Md.
24. Shahawy, M., "Feasibility Study of Transversely Prestressed Double Tee Bridges," *PCI Journal*, Vol. 35, No. 5, 1990, Sept.–Oct. 1990.
25. Shahawy, M., "Load Testing of Transversely Prestressed Double Tee Bridges," *Journal of the Prefabricated/Prestressed Concrete Institute*, Vol. 37, No. 2, March–April, 1992, pp. 86–99.
26. Scanlon, A., A. Aswad, and J. Stellar, "Prefabricated Post-Tensioned Abutment System and Prefabricated Superstructure for Rapid On-Site Construction," *Transportation Research Record 1814*, Transporta-

- tion Research Board, National Research Council, Washington, D.C., 2002, pp. 65–71.
27. Sprinkel, M.M., *Synthesis of Highway Practice 119: Prefabricated Bridge Elements and Systems*, Transportation Research Board, National Research Council, Washington, D.C., 1985, 75 pp.
  28. Billington, S.L. and J.E. Breen, “Development Process for a New Substructure System for Standard Bridges,” *Symposium on Structures for the Future—The Search for Quality*, IABSE, Rio de Janeiro, Brazil, Vol. 83, 1999.
  29. *Guide Specification and Commentary for Vessel Collision Design of Highway Bridges*, American Association of State Highway and Transportation Officials, Washington, D.C., 149 pp.
  30. Bornscheuer, B.-F. and S. Eisle, “Die Nesenbachtalbrücke—Vom Wettbewerb bis zur Ausschreibung, Nesenbachtalbrücke (From Competition to Submission),” *Stahlbau*, Vol. 67, No. 11, 1998, pp. 827–830.
  31. Weber, J., “Erstes Brückenbauwerk aus Spannbetonfertigteilen mit Hochleistungsbeton B 85, (Bridge Construction Made Using Prefabricated Prestressed Members from High-Performance Concrete B 85),” *Betonwerk und Fertigteil-Technik/Concrete Prefabricating (Plant and Technology)*, Vol. 68, No. 2, 2002, pp. 52–54.
  32. Collings, D., “The A13 Viaduct: Construction of a Large Monolithic Concrete Bridge Deck,” *Proceedings of the Institution of Civil Engineers: Structures and Buildings*, Vol. 146, No. 1, 2001, pp. 85–91.
  33. Nasir, S., S. Gupta, H. Umehara, and I. Hirasawa, “An Efficient Method for the Construction of Bridge Piers,” *Engineering Structures*, Vol. 23, No. 9, 2001, pp. 1142–1151.
  34. Shekar, V., S.H. Petro, and H.V.S. GangaRao, “Construction of Fiber-Reinforced Plastic Modular Decks for Highway Bridges,” *Transportation Research Record 1813*, Transportation Research Board, National Research Council, Washington, D.C., 2002, pp. 203–209.
  35. Bakis, C.E., et al., “Fiber-Reinforced Polymer Composites for Construction: State-of-the-Art Review,” *Journal of Composites for Construction*, Vol. 6, No. 2, 2002, pp. 73–87.
  36. Dieter, D.A., J.S. Dietsche, L.C. Bank, M.G. Oliva, and J.S. Russell, “Concrete Bridge Decks Constructed with Fiber-Reinforced Polymer Stay-in-Place Forms and Grid Reinforcing,” *Transportation Research Record 1814*, Transportation Research Board, National Research Council, Washington, D.C., 2002, pp. 219–226.
  37. Iskander, M.G. and M. Hassan, “State of the Practice Review in FRP Composites Piling,” *Journal of Composites for Construction*, Vol. 2, No. 3, 1998, pp. 116–120.
  38. Mirmiran, A. and M. Shahawy, “A New Concrete-Filled Hollow FRP Composite Column,” *Composites Part B: Engineering, Special Issue on Infrastructure*, Vol. 27B, No. 3–4, 1996, pp. 263–268.
  39. Mirmiran, A. and M. Shahawy, “Behavior of Concrete Columns Confined by Fiber Composites,” *Journal of Structural Engineering*, Vol. 123, No. 5, 1997, pp. 583–590.
  40. Mirmiran, A., S. Cabrera, M. Samaan, and M. Shahawy, “Design, Manufacture, and Testing of a New Hybrid Column,” *Construction and Building Materials*, Vol. 12, No. 1, 1998, pp. 39–49.
  41. Mirmiran, A., M. Shahawy, M. Samaan, H. El Echary, J.C. Mastrapa, and O. Pico, “Effect of Column Parameters on FRP-Confined Concrete,” *Journal of Composites for Construction*, Vol. 2, No. 4, 1998, pp. 175–185.
  42. Seible, F., “U.S. Perspective of Advanced Composites Bridge Technology in Europe and Japan,” *Proceedings of the 2nd International Conference on Composites in Infrastructures* (H. Saadatmanesh and M.R. Ehsani, eds.), Tucson, Ariz., Vol. 2, 1998, pp. 605–636.
  43. “Europe’s First Composite Highway Bridge Opens in Oxfordshire,” *Composites Technology*, Dec. 2002, p. 11.
  44. Keller, T., “New Bridges and Buildings Constructed from Translucent GFRP Sandwich Panels and Glued GFRP Elements,” *Proceedings of the 3rd Conference on Advanced Composite Materials in Bridges and Structures* (J. Humar and A.G. Razaqpur, eds.), Ottawa, Ontario, Canada, 2000, pp. 785–792.
  45. Sasaki, I., I. Nishizaki, and H. Sakamoto, “A Bridge Constructed Entirely of Composites and the Results of Load Testing,” *Proceedings of the 2nd International Conference on Composites in Infrastructures* (H. Saadatmanesh and M. R. Ehsani, eds.), Tucson, Ariz., Vol. 1, 1998, pp. 657–666.

## BIBLIOGRAPHY

- Ashford, S.A. and W. Jakrapiyanun, "Drivability of Glass FRP Composites Piling," *Journal of Composites for Construction*, Vol. 5, No. 1, 2001, pp. 58–60.
- Bakht, B. and A.A. Mufti, "Five Steel-Free Deck Slabs in Canada," *Structural Engineering International*, International Association for Bridge and Structural Engineering, Zurich, Switzerland, Vol. 8, No. 3, 1998, pp. 1–7.
- Bradberry, T.E., "FRP-Bar-Reinforced Concrete Bridge Decks Reinforced with Fiber-Reinforced Bars (with Discussion and Closure)," *Transportation Research Record 1770*, Transportation Research Board, National Research Council, Washington, D.C., pp. 94–104.
- Chajes, M., H. Shenton, D. Mertz, and J. Gillespie, "Structural Monitoring of Advanced Composite Bridge," *Proceedings of US-Canada-Europe Workshop on Bridge Engineering: Recent Advances in Bridge Engineering, Evaluation, Management, and Repair* (U. Meier and R. Betti, eds.), Dubendorf, Switzerland, 1997, pp. 299–302.
- Chajes, M., J. Gillespie, D. Mertz, and H. Shenton, "Advanced Composite Bridges in Delaware," *Proceedings of the 2nd International Conference on Composites in Infrastructures* (H. Saadatmanesh and M.R. Ehsani, eds.), Tucson, Ariz., Vol. 1, 1998, pp. 645–650.
- Chajes, M.J., H.W. Shenton, and W.W. Finch, Jr., "Performance of a Glass Fiber-Reinforced Polymer Deck on Steel Girder Bridge," *Transportation Research Record 1770*, Transportation Research Board, National Research Council, Washington, D.C., 2001, pp. 105–112.
- Culmo, M.P., "Rapid Bridge Deck Replacement Using Full-Depth Precast Concrete Slabs," *Transportation Research Record 1712*, Transportation Research Board, National Research Council, Washington, D.C., 2000, pp. 139–146.
- Foster, D.C., D. Richards, and B.R. Bogner, "Design and Installation of Fiber-Reinforced Polymer Composite Bridge," *Journal of Composites for Construction*, Vol. 4, No. 1, 2000, pp. 33–37.
- GangaRao, H.V.S. and K. Laosiriphong, "Design and Construction of Market Street Bridge," *Proceedings of the 46th International Society for the Advancement of Material and Process Engineering, (SAMPE) Symposium and Exhibition*, Long Beach, Calif., 2001, pp. 1321–1330.
- Grace, N.F. and G. Abdel-Sayed, "Double Tee and CFRP/GFRP Bridge System," *Concrete International*, Vol. 18, No. 2, 1996, pp. 39–44.
- Guide for the Design and Construction of Concrete Reinforced with FRP Bars*, ACI 440.1R-01, American Concrete Institute, Farmington Hills, Mich., 2002.
- Hayes, M.D., D. Ohanehi, J.J. Lesko, T.E. Cousins, and D. Witcher, "Performance of Tube and Plate Fiberglass Composite Bridge Deck," *Journal of Composites for Construction*, Vol. 4, No. 2, 2000, pp. 48–55.
- Hearn, G., R.L. Purvis, P. Thompson, W.H. Bushman, K.K. McGhee, and W.T. McKeel, "Bridge Maintenance and Management—A Look to the Future," A3C06: Committee on Structures Maintenance and Management, Transportation Research Board, Washington, D.C., 2002.
- Henriquez, O.E., J.M. Plecnik, E.P. Munley, and J.D. Cooper, "Development of an FRP System for Bridge Deck Replacement," *Proceedings of the US-Canada-Europe Workshop on Bridge Engineering: Recent Advances in Bridge Engineering, Evaluation, Management, and Repair* (U. Meier and R. Betti, eds.), Dubendorf, Switzerland, 1997, pp. 197–206.
- Issa, M.A., A.T. Idriss, I.I. Kaspar, and S.Y. Khayat, "Full Depth and Prefabricated, Prestressed Concrete Bridge Deck Panels," *PCI Journal*, Jan.–Feb. 1995, pp. 59–80.
- Kleiber, F.W., T.J. Wipf, and B.M. Phares, "Prefabricated Units for Simple Span Bridge," *Proceedings of the US-Canada-Europe Workshop on Bridge Engineering: Recent Advances in Bridge Engineering, Evaluation, Management and Repair* (U. Meier and R. Betti, eds.), Dubendorf, Switzerland, 1997, pp. 223–230.
- Lang, A.S., *Synthesis of Highway Practice 53: Precast Concrete Elements for Transportation Facilities*, Transportation Research Board, National Research Council, Washington, D.C., 1978, 48 pp.
- Lesko, J., M. Hayes, J. Haramis, J. Hou, T. Cousins, J. Gomez, and P. Massarelli, "Laboratory and Field Characterization of the Tom's Creek Bridge Composite Superstructure," *Proceedings of the 2nd International Conference on Composites in Infrastructures* (H. Saadatmanesh and M.R. Ehsani, eds.), Tucson, Ariz., Vol. 1, 1998, pp. 634–644.
- Lopez-Anido, R. and H.V.S. GangaRao, "Design and Construction of Composite Material Bridges," *Proceedings of the US-Canada-Europe Workshop on Bridge Engineering: Recent Advances in Bridge Engineering, Evaluation, Management, and Repair* (U. Meier and R. Betti, eds.), Dubendorf, Switzerland, 1997, pp. 265–272.
- Lopez-Anido, R., D.L. Troutman, and J.P. Busel, "Fabrication and Installation of Modular FRP Composite Bridge Deck," *Proceedings of International Composites Expo '98*, Nashville, Tenn., 1998.
- Mufti, A.A., L.G. Jaeger, B. Bakht, and L.D. Wegner, "Experimental Investigation of FRC Slabs Without Internal Steel Reinforcement," *Canadian Journal of Civil Engineering*, Vol. 20, No. 3, 1993, pp. 398–406.
- Newhook, J.P., B. Bakht, G. Tadros, and A.A. Mufti, "Design and Construction of a Concrete Marine Structure Using Innovative Technologies," *Proceeding of the 3rd International Conference on Advanced Composite Materials in Bridges and Structures*, Ottawa, Ontario, Canada, 2000, pp. 777–784.

- Podolny, W., Jr., and J.M. Muller, *Construction and Design of Prestressed Concrete Segmental Bridges*, John Wiley and Sons, New York, N.Y., 1982.
- Sargent, D.D., A.A. Mufti, and B. Bakht, "Design, Construction, and Field Testing of Steel-Free Arch-Panel Bridge Deck for Forestry Bridges," *Proceedings of the Annual Conference of the Canadian Society for Civil Engineering*, Regina, Saskatchewan, Canada, Vol. 1, 1999, pp. 95-105.
- Szak, P.J., B.N. Robson, I.E. Harik, and B. Brailsford, "The Clear Creek Hybrid Composite I-Girder Pedestrian Bridge," *Journal of Composites for Construction*, Vol. 3, No. 2, 1999, pp. 101-108.
- Tadros, M.K., S.S. Badie, M.C. Baishya, and T. Yamane, "Innovative Prestressed Concrete Bridge Deck Panel Systems," Presented at the 79th Annual Meeting of the Transportation Research Board (CD-ROM), Washington, D.C., 2000.
- Walker, H.S., "Fiberglass Bridges and Bridge Decks," *Proceedings of the 2nd International Conference on Composites in Infrastructures* (H. Saadatmanesh and M.R. Ehsani, eds.), Tucson, Ariz., Vol. 1, 1998, pp. 651-656.
- Williams, B., S. Rizkalla, E. Shehata, and D. Stewart, "Development of Modular GFRP Bridge Decks," *Proceedings of the 3rd Conference on Advanced Composite Materials in Bridges and Structures* (J. Humar and A. Ghani Razaqpur, eds.), Ottawa, Ontario, Canada, 2000, pp. 95-102.
- Yamane, T., M.K. Tadros, S.S. Badie, and M.C. Baishya, "Full Depth Prefabricated, Prestressed Concrete Bridge Deck System," *PCI Journal*, May-June 1998, pp. 51-66.
- Zoghi, M., D.N. Farhey, and D.C. Foster, "Construction and Performance Evaluation of a Fiber-Reinforced Polymer Composite Bridge," Presented at 81st Annual Meeting of the Transportation Research Board (CD-ROM), Washington, D.C., 2002.

## APPENDIX A

### Survey Questionnaire

#### PREFABRICATED BRIDGE ELEMENTS AND SYSTEMS TO LIMIT TRAFFIC DISRUPTION DURING CONSTRUCTION

NCHRP PROJECT 20-5, TOPIC 33-02

#### QUESTIONNAIRE

Increased emphasis is being placed on improving workzone safety and minimizing traffic disruption associated with highway bridge construction projects, while maintaining construction quality. The use of innovative prefabricated systems/elements in bridge design and construction can limit traffic disruptions and improve workzone safety. This survey solicits information on the use of innovative prefabricated systems\*/elements\*\* in the new bridge construction and rehabilitation and replacement of commonly used bridges using the “Get in, Get out, and Stay out” philosophy. Information on new construction techniques and innovative use of materials that have not been fully implemented is also solicited.

*\*A system is an innovative combination of prefabricated elements (concrete, steel, or any advanced materials) eliminating (or considerably limiting— see note below) cast-in-place concrete.*

*\*\*Innovative use of prefabricated elements such as pier caps, columns, and full-depth decks, etc., can effectively minimize construction time, traffic disruption, and the impact of construction activities on the environment. Elements in this context exclude common elements such as typical beams.*

*Note: “considerably limiting” means, for example, cast-in-place closure pours only. Also, “cast-in-place” concrete means concrete that is cast at its final location.*

The information provided by you will be invaluable to the development of a summary report on the current research and practices used in this important area.

Please return your completed questionnaire, along with any supporting documents, to:

Mohsen A. Shahawy, Ph.D., P.E.  
SDR Engineering Consultants Inc.  
2434 Oakdale Street  
Tallahassee, Florida 32308  
Tel. (850) 386-9197 Fax (850) 385-0695  
E-mail: shahawy@sdrengineering.com

If you have any questions, please call Dr. Shahawy, or e-mail him.

Below, please provide the name of the person completing this questionnaire or someone else who may be contacted to obtain any needed follow-up information.

Name and title: \_\_\_\_\_

Phone, e-mail: \_\_\_\_\_

Agency: \_\_\_\_\_

Address: \_\_\_\_\_

**Thank you very much for your valuable input.**

1. Did you use any innovative prefabricated systems or elements in new bridge construction, rehabilitation, and replacement?

---



---

2. What are the primary reasons for selecting the innovative systems/elements? (Check all that apply.)

Specify System/element Used	To minimize construction delays	To minimize lane closure	To improve quality and durability	To improve safety	Cost	To facilitate construction	To minimize environmental impact	Proposed by contractor*	Other specify
(a)									
(b)									
(c)									
(d)									

\* Please provide contractor contact information.

3. Please specify the type and number of bridges where innovative prefabricated systems/elements were used? The types listed in the table below are examples and for different types, please provide summary on a separate page. If the total number in any category is a high number, please feel free to estimate.

System/Element Type		Total number of bridges	No. of new bridges	No. of rehabilitated/replaced bridges	Date of first installation	Fabricator produced
(a) Bridge Deck	Deck panels (not full depth)					
	Full-depth prefabricated, prestressed deck panel					
	Steel decks					
	Full-depth FRP decks					
	Permanent FRP deck form					
	Other (specify)					
(b) Composite Superstructure Systems (prefabricated deck and girder units) Note: Indicate with "*" if suitable for direct contact traffic.	Concrete deck with concrete girders					
	Concrete deck with steel girders					
	Steel decks with steel girders					
	Steel decks with concrete girders					
	FRP decks with concrete girders					
	FRP decks with steel girders					
	FRP decks with FRP girders					
	Transversely post-tensioned double-tee					
	Transversely post-tensioned box					
Other (specify)						
(c) Substructures	Prefabricated caps					
	Prefabricated columns					
	Segmental columns					
	Steel columns					
	Prefabricated cap/column system					
	FRP composite piles					
	Other (specify)					
(d) Total Bridge System	Prefabricated super/substructure with steel girders					
	Prefabricated super/substructure with concrete girders					
	Other (specify)					
(e) Miscellaneous	Innovative girders (specify type)					
	Diaphragms					
	Other (specify)					

4. Did you utilize the techniques where a complete bridge span is assembled off-site and transported to the site and erected into place? If yes, please provide a summary of the application and whether it was successful in terms of construction time and cost. (Use a separate page if necessary.)

---



---



---

5. How far from the bridge were the innovative systems/elements fabricated?

Specify System/Element Used	Less than one mile	1 to 50 miles	51 to 200 miles	More than 200 miles
(a)				
(b)				
(c)				
(d)				

6. How were the elements transported from the plant to the site? Please elaborate on any special issues that came up on the job. (Use separate sheet if necessary.)

Specify System/Element Used	Truck	Rail	Barge	Other
(a)				
(b)				
(c)				
(d)				

---



---

7. What is the lane closure time, in days per foot of lane, required for the installation of the system/element and the conventional alternative solution?

Specify System/Element Used	Lane closure time for the <b>system/element</b>	Lane closure time for the <b>alternative</b>
(a)		
(b)		
(c)		
(d)		

8. In which of the following roadway systems were the innovative prefabricated systems/elements used?

Specify System/Element Used	ADT/lane						Other
	Interstate		Primary		Secondary		
	5,000 to 15,000	>15,000	3,000 to 10,000	>10,000	500 to 2,500	>2,500	
(a)							
(b)							
(c)							
(d)							

9. What is the cost differential in dollars per square foot of deck surface for the innovative prefabricated systems/elements compared with the other type of possible alternatives? What is the saving in time lane closure in percent compared with other types of possible alternatives? (If numbers not available, please give savings in percent with respect to alternatives.)

Specify System/Element Used	Cost differential for the system with respect to alternative (sign convention: - = prefab costs less; + = prefab costs more)					Time lane closure saving with respect to alternative (%)
	Initial	Life cycle	Annual maintenance	Removal	Other	
(a)						
(b)						
(c)						
(d)						

10. Do you know of any associated maintenance problems or other drawbacks that might impact the life-cycle cost of these innovative prefabricated systems/elements? If yes, please specify. (Use separate page if necessary.)

---



---



---

11. What is the number of bridges using innovative prefabricated deck/girder systems with and without overlay, and what is the satisfaction rate of high-speed rideability on bridges with direct traffic application (i.e., no overlay)?

Specify Deck/Girder System Used	With overlay		Without overlay			
	Asphalt	Polymer concrete	With grinding		Others	
			Number	Rideability rate (%)	Number	Rideability rate (%)
(a)						
(b)						
(c)						
(d)						

12. In your opinion what areas need further attention to encourage a wide use of these innovative systems/elements?

Specify System/Element Used	Areas requiring further attention							
	None	Initial cost	Length/weight <sup>a</sup>	Durability	Design/specifications	Connections	Experienced contractors	Others (specify)
(a)								
(b)								
(c)								
(d)								

<sup>a</sup> Relates to transportation/erection.

13. In your opinion, what portions of the bridge are most suited for prefabrication and could result in significant reduction in construction time?

---



---



---



---

- 14. Do you know of any innovative system/element or method used in your state or elsewhere in a DOT project or other agencies (e.g., railroad industry) that can be of interest? Please provide information on the system and contacts.

---

---

---

---

- 15. Are you aware of any preassembly methods that have been tried successfully or any new assembling techniques that could be used to accelerate the construction time?

---

---

---

---

- 16. Were any innovative contracting methods, such as incentives and disincentives, important to the successful use of the innovative prefabricated elements or systems used? Please specify.

---

---

**Thank You!**

**Remember! Please feel free to add comments by referring to the relevant question and enclose any information you believe is relevant to the answers given in the questionnaire, including applicable research results, policies, specification language, case law, and other information that might be of interest to other states.**

Abbreviations used without definition in TRB Publications:

AASHO	American Association of State Highway Officials
AASHTO	American Association of State Highway and Transportation Officials
APTA	American Public Transportation Association
ASCE	American Society of Civil Engineers
ASME	American Society of Mechanical Engineers
ASTM	American Society for Testing and Materials
CTAA	Community Transportation Association of America
CTBSSP	Commercial Truck and Bus Safety Synthesis Program
FAA	Federal Aviation Administration
FHWA	Federal Highway Administration
FMCSA	Federal Motor Carrier Safety Administration
FRA	Federal Railroad Administration
FTA	Federal Transit Administration
IEEE	Institute of Electrical and Electronics Engineers
ITE	Institute of Transportation Engineers
NCHRP	National Cooperative Highway Research Program
NCTRP	National Cooperative Transit Research and Development Program
NHTSA	National Highway Traffic Safety Administration
NTSB	National Transportation Safety Board
SAE	Society of Automotive Engineers
TCRP	Transit Cooperative Research Program
TRB	Transportation Research Board
U.S.DOT	United States Department of Transportation