

NATIONAL
ACADEMIES

Sciences
Engineering
Medicine

TRB TRANSPORTATION RESEARCH BOARD

TRB Webinar: Designing for Performance in Perpetual Asphalt Pavements

March 19, 2026

2:00 PM – 3:30 PM (eastern)

PDH Certification Information

1.5 Professional Development Hour (PDH) – see follow-up email

You must attend the entire webinar.

Questions? Contact Andie Pitchford at TRBwebinar@nas.edu

The Transportation Research Board has met the standards and requirements of the Registered Continuing Education Program. Credit earned on completion of this program will be reported to RCEP at RCEP.net. A certificate of completion will be issued to each participant. As such, it does not include content that may be deemed or construed to be an approval or endorsement by the RCEP.

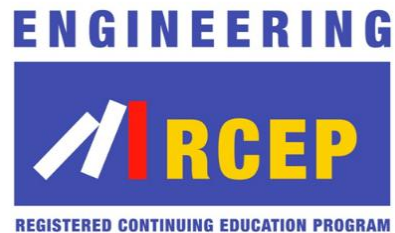

Purpose Statement

This webinar will introduce the concepts needed to complete a design and highlight how agencies are applying them to design perpetual highway asphalt pavements. Presenters will also share how one agency developed an experimental plan to support the construction of perpetual airfield asphalt pavement.

Learning Objectives

At the end of this webinar, participants will be able to:

- (1) Describe key concepts required to complete a perpetual pavement design
- (2) Apply perpetual pavement design principles to highway asphalt pavement projects
- (3) Outline how an agency developed and implemented an experimental plan to construct a perpetual airfield asphalt pavement

Questions and Answers

- Please type your questions into your webinar control panel
- We will read your questions out loud, and answer as many as time allows

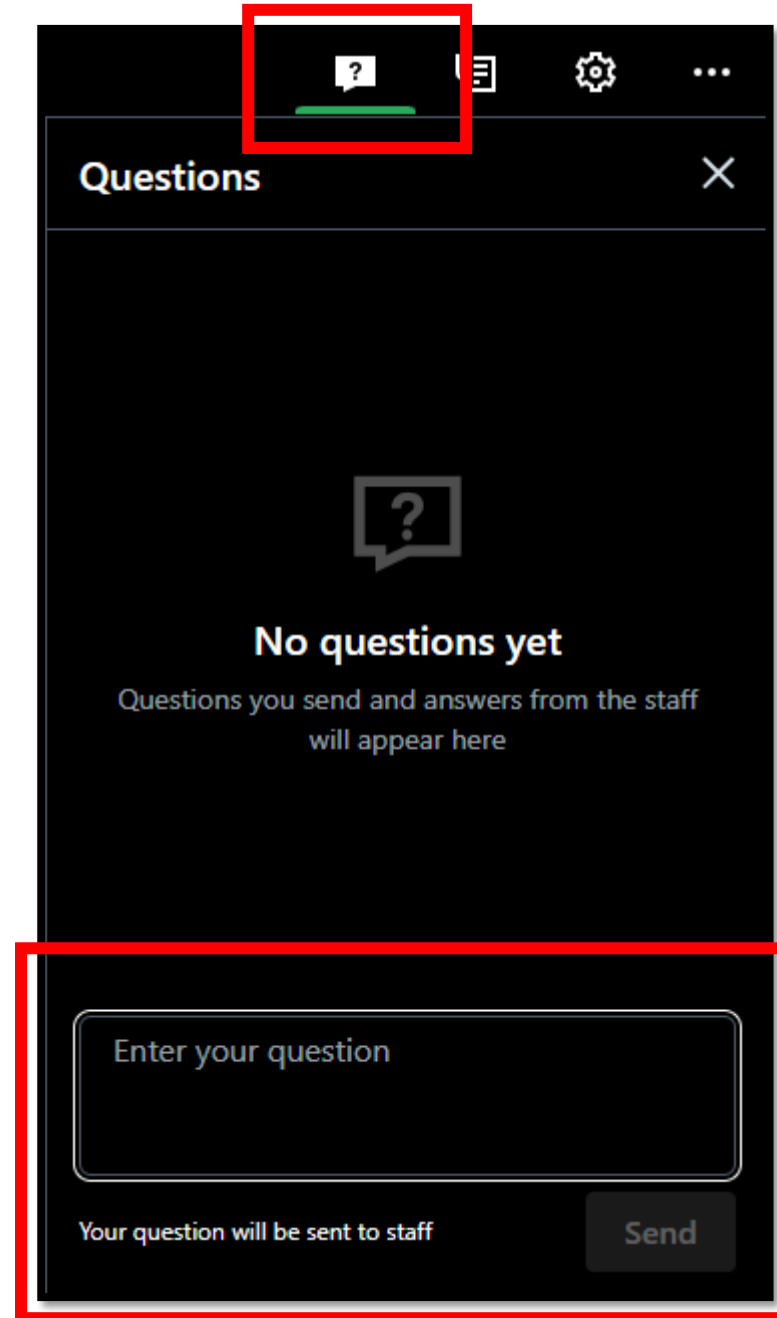

Today's Presenters



Dr. Buzz Powell
bpowell@asphaltpavement.org

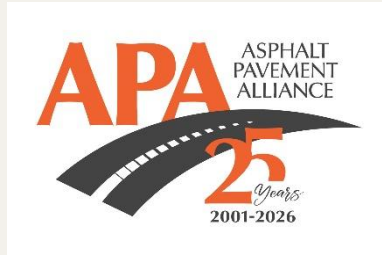

Dr. David Timm
timmdav@auburn.edu



Dr. Bill Vavrik
wwavrik@ara.com



Dr. Navneet Garg
navneet.garg@faa.gov



Perpetual Pavement Principles



Dr. David Timm, P.E., F.ASCE

March 19, 2026



Structural Pavement Design

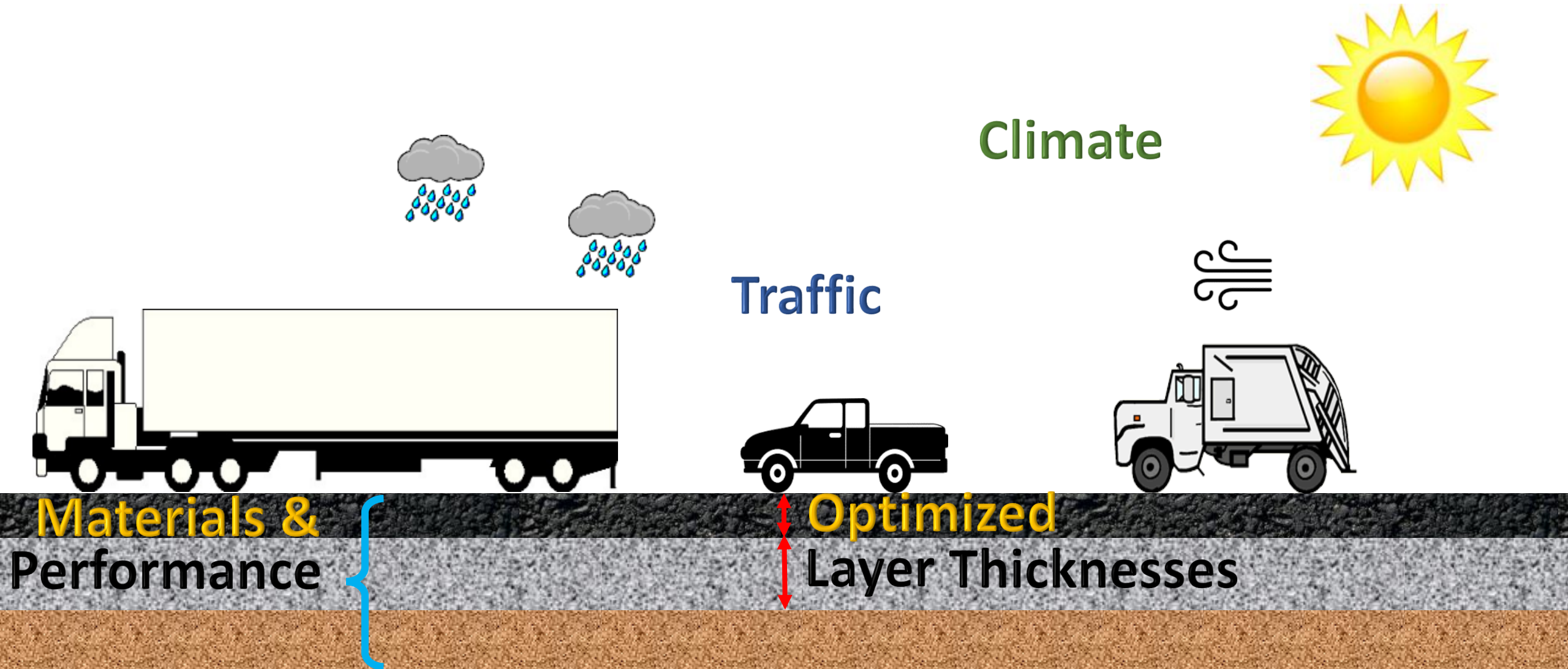

Structural Pavement Design Evolution

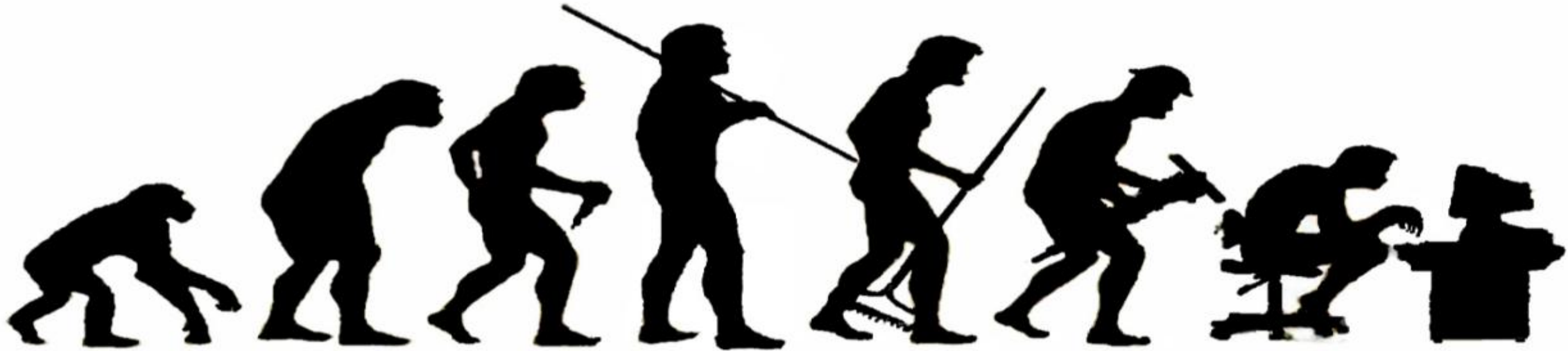

**Pre 1950's
Experience**

**1960's
Development of
Empirical Methods**

**1980's
Initial
Mechanistic-
Empirical
Methods**

**1990's
NCRHP 1-37A
M-E Design**

**2000's
Implementation
of M-E Methods
&
**Perpetual
Pavements****

What is a Perpetual Pavement?

- 35+ years of service
- Minimal structural improvements (<4" AC gain)
- Resurfacing infrequently (>13 years)
- No *deep* structural distresses



Design to Prevent Deep Structural Distresses



Perpetual Pavement Awards

- **By PERFORMANCE**
 - Existing pavements
 - >35 years old
 - Minimal structural improvements
 - Infrequent rehabilitation
- **By DESIGN**
 - Purposefully designed according to perpetual pavement criteria
- **By CONVERSION**
 - Converting existing pavement, through rehabilitation, into a perpetual pavement



By Performance Award Winners through 2024

- 217 Awards
- 36 States
- Age Range
 - 34 to 102 Years
- Average Age
 - 50.43 Years

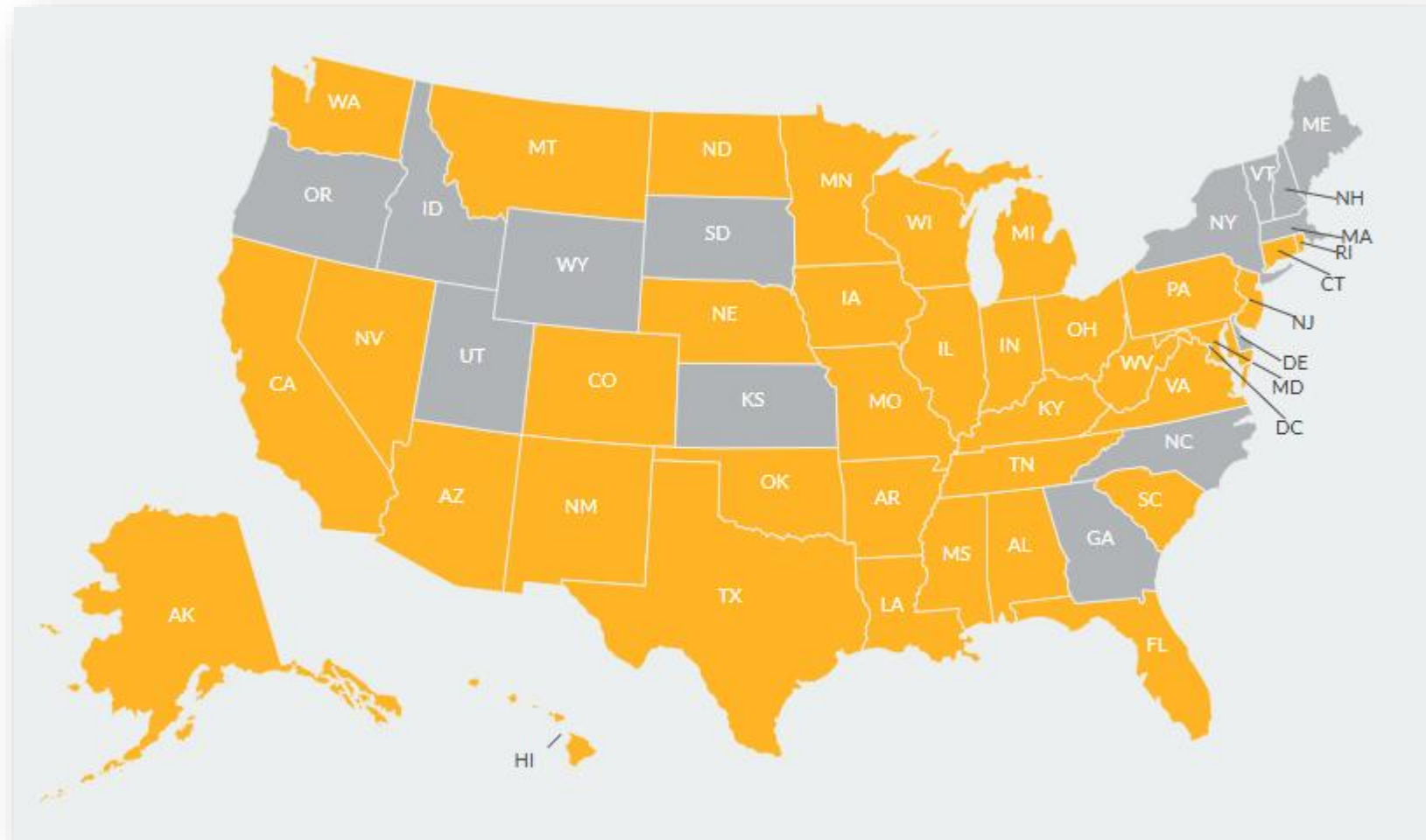

<https://www.drivesphalt.org/awards/perpetual-by-performance>

Typical Perpetual Pavement Cross-Section



Typical Depths

Materials

1.5 – 3"



High Quality AC

4 – 7"

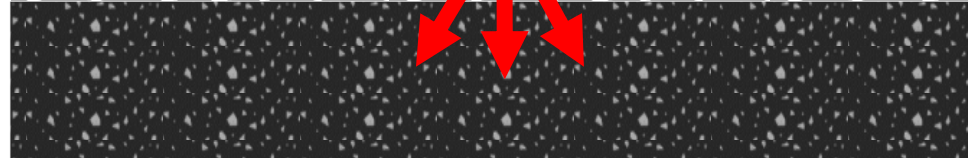

High Modulus,
Rut Resistant AC

3 – 4"



Fatigue Resistant AC



Strong
Pavement
Foundation
(consider drainage)



Newcomb, 2001

TRANSPORTATION RESEARCH CIRCULAR

Number 503, December 2001
ISSN 0097-8515

Perpetual Bituminous Pavements

TRB Committee on General Issues in Asphalt Technology (A2D05)

Joe W. Button, *Chair*

J. Don Brock
Ronald Collins
Eileen Connolly
Dale S. Decker
Denis E. Donnelly
Frank Fee

Thomas P. Harman
Robert D. Horan
Gerald A. Huber
Prithvi S. Kandhal
Gayle N. King
David E. Newcomb
Harold R. Paul

James A. Scheroeman
Scott Shuler
H. Barry Takallou
Donald E. Watson
John J. Weigel, Jr.
Randy C. West

Frederick D. Hejl, *TRB Staff Representative*

Subscriber category
IIB materials and construction

Website: TRB.org

Transportation Research Board
National Research Center
2101 Constitution Avenue, NW
Washington, DC 20418

<https://onlinepubs.trb.org/Onlinepubs/trcircular/503/503.pdf>

Mechanistic-Empirical **PERPETUAL** Pavement Design

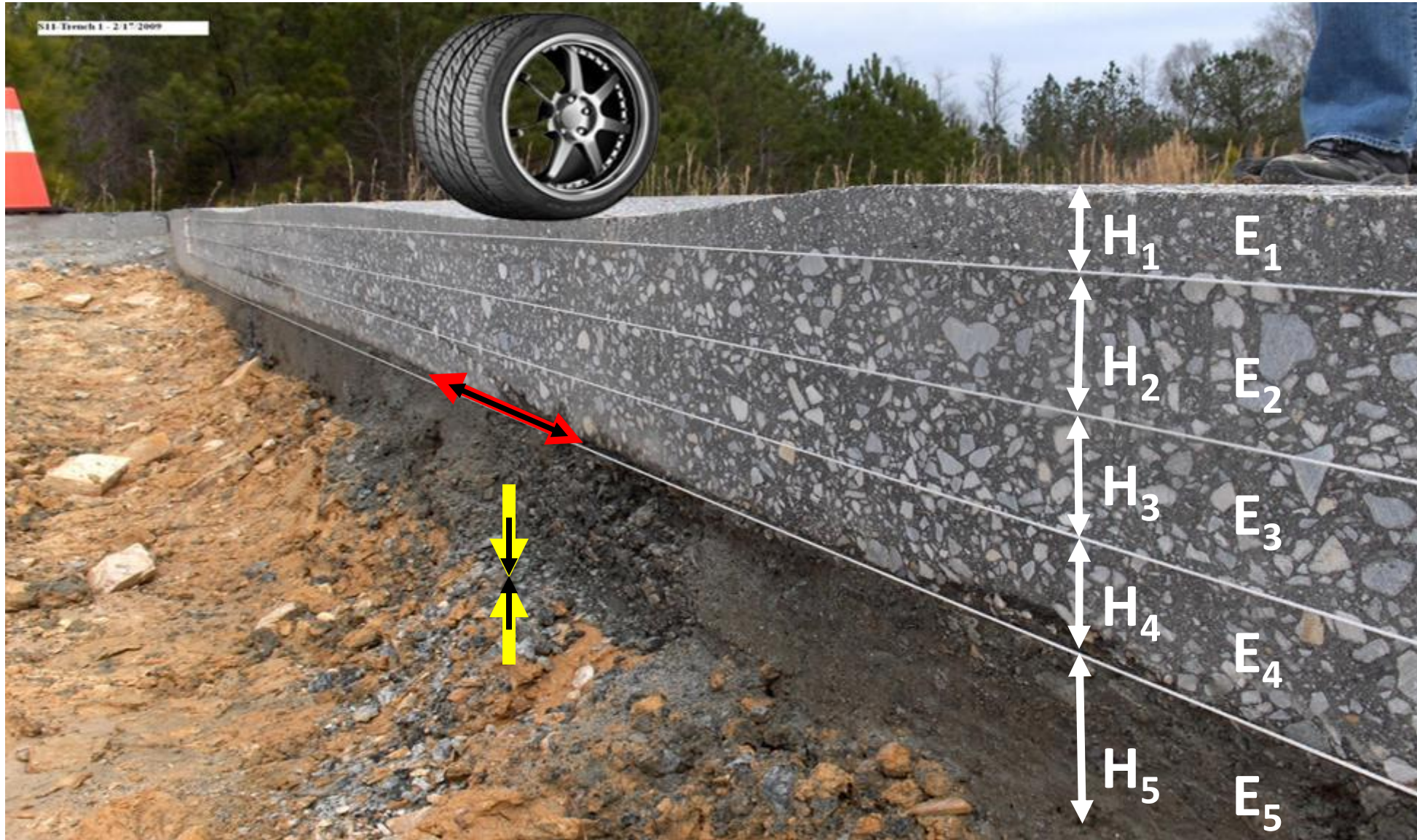

Fatigue Endurance Limits for Asphalt Concrete (Lab)

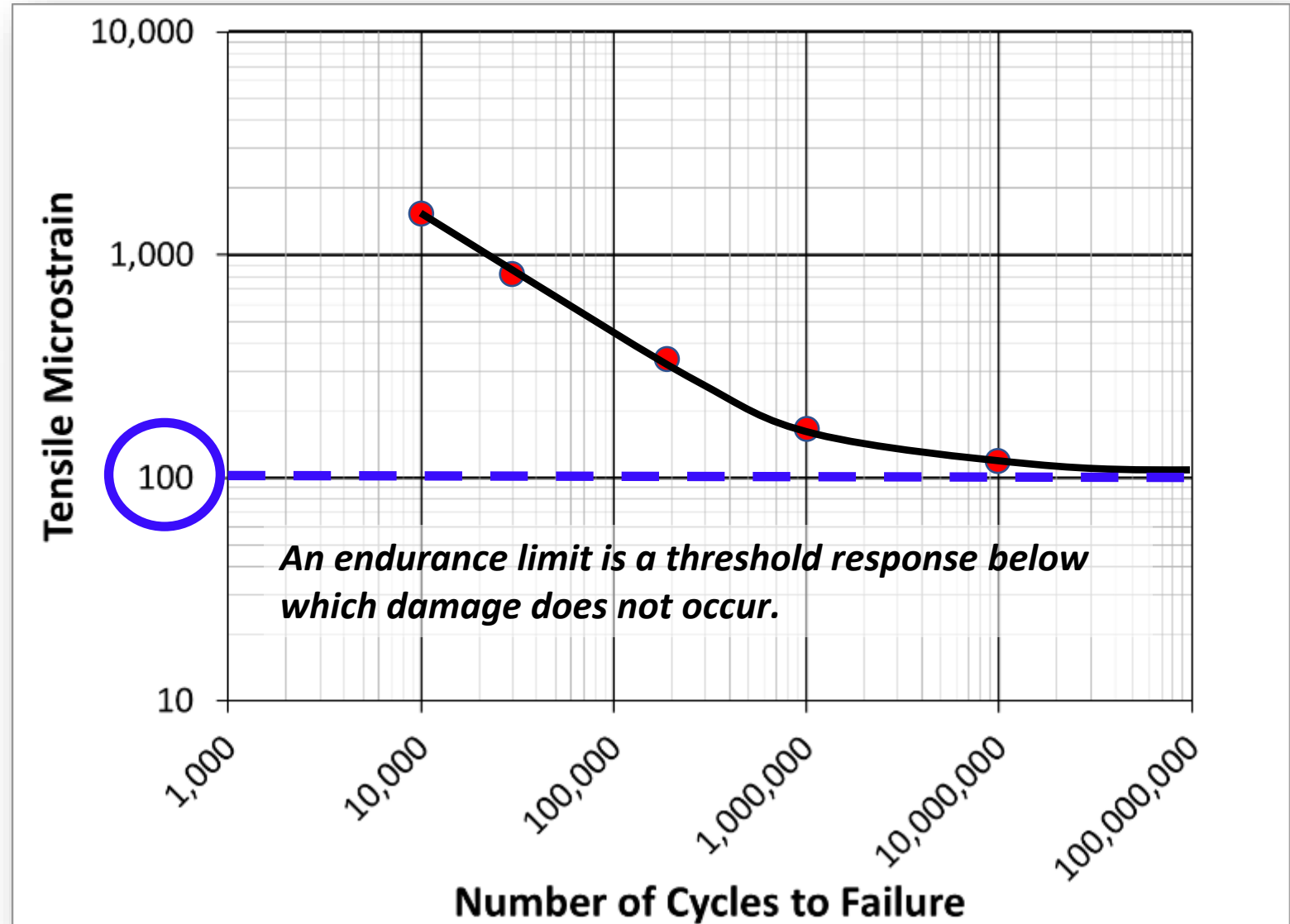
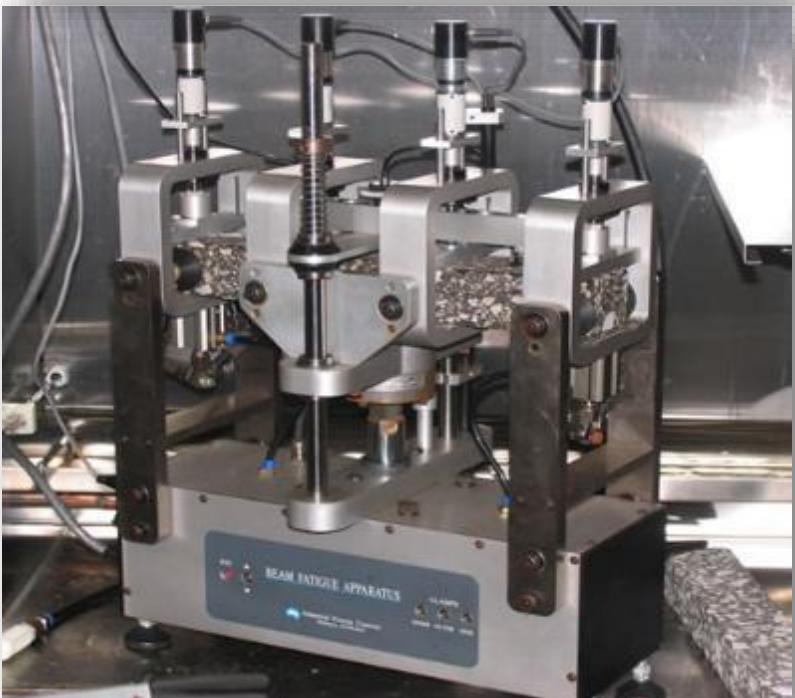

Fatigue Endurance Limits for Asphalt Concrete (Field)

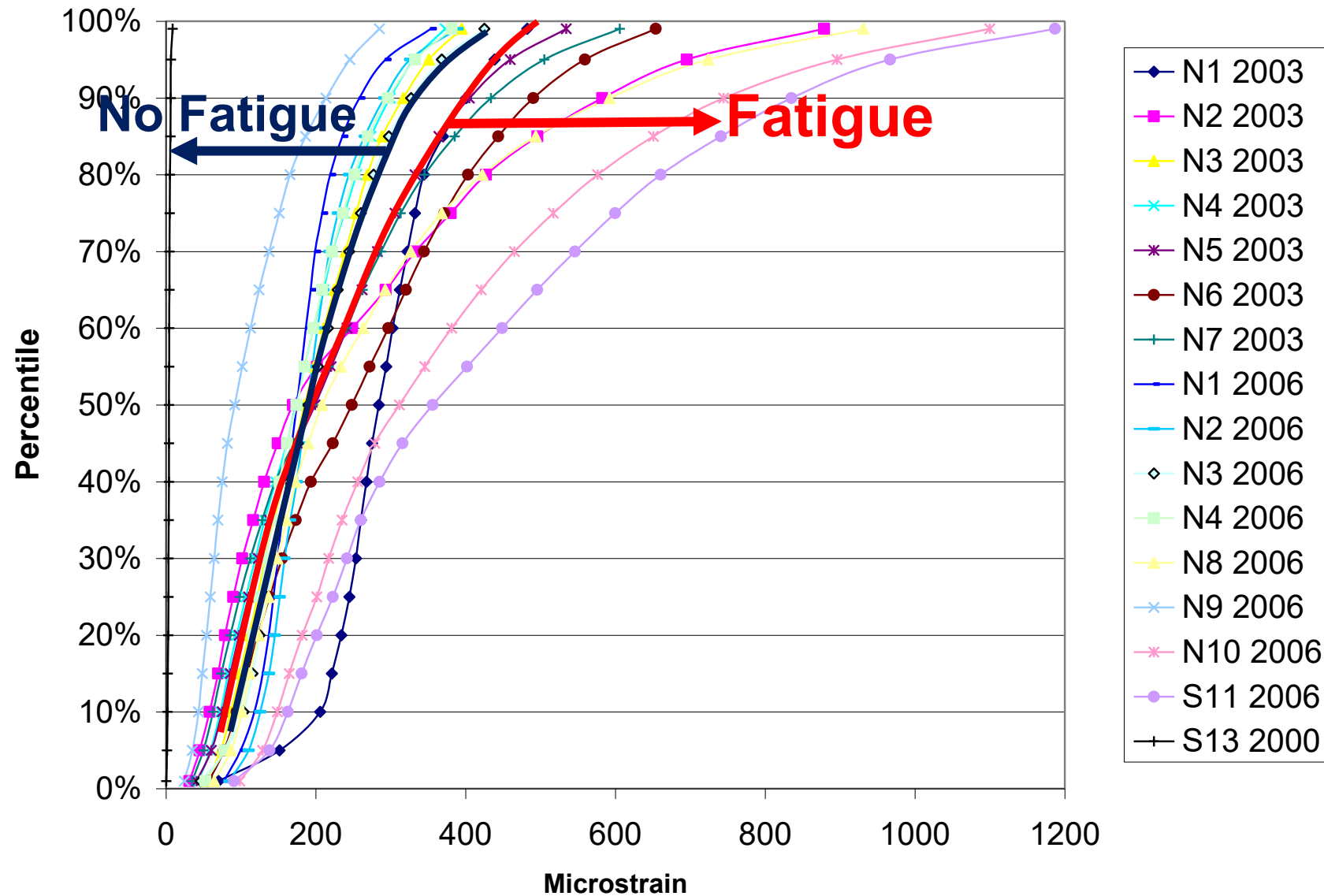

Rutting Endurance Limit – Vertical Strain Criteria

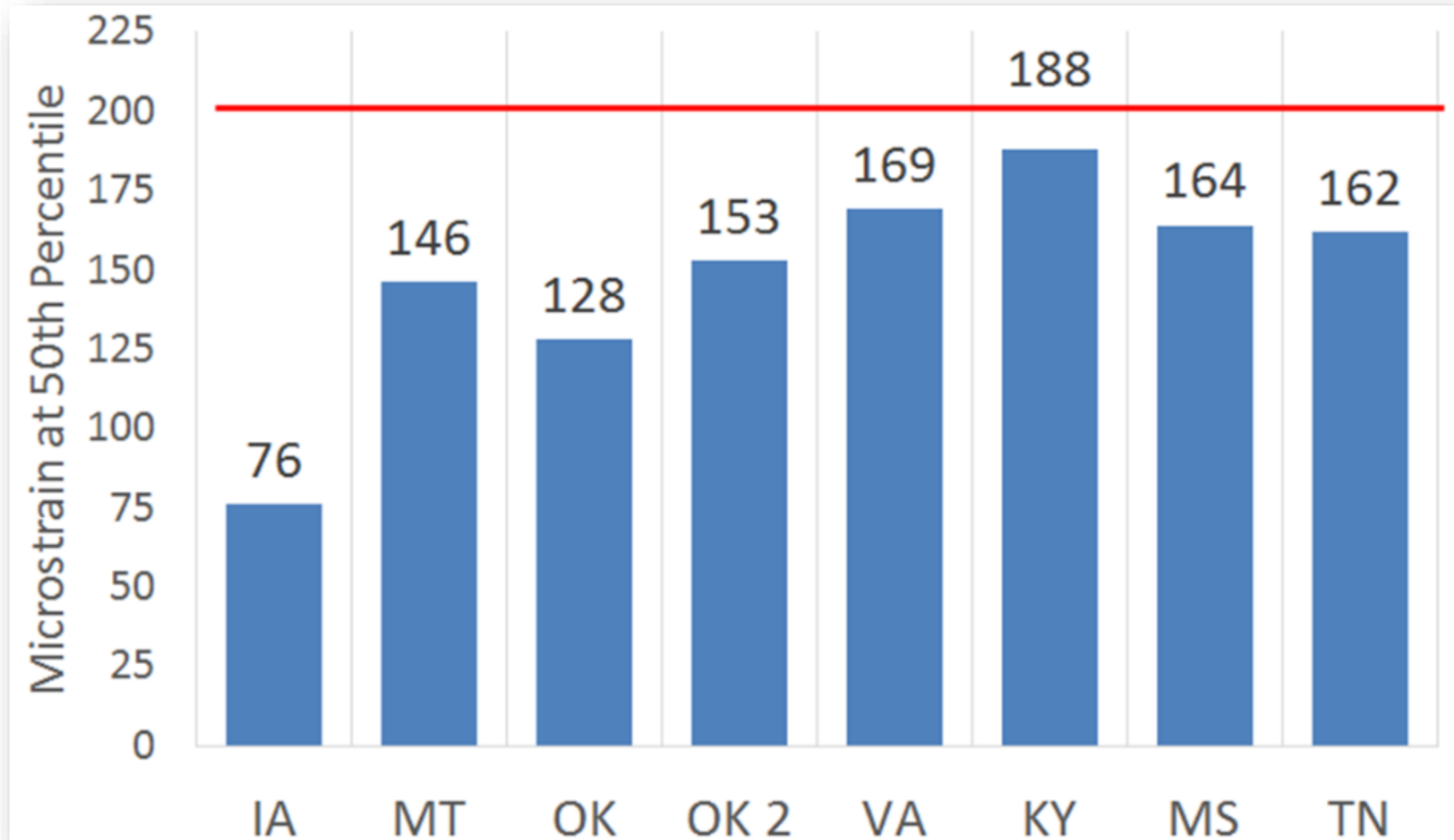

Perpetual Pavement Design Tools

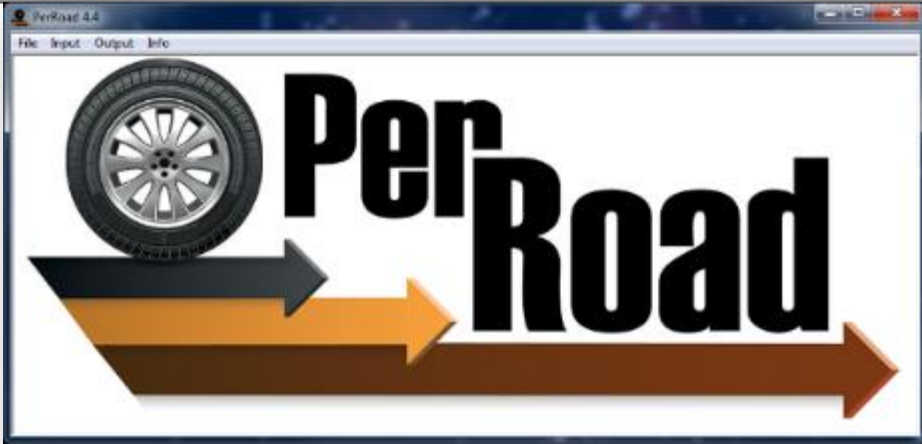

PerRoadXPress

Press F1 to access full help file. Press Shift+F1 to access context-sensitive pop-up help.

Functional Classification:

Two-Way AADT: (500 to 5000)

%Trucks: (1 to 20)

%Growth: (0 to 3)

Design Trucks: (Total Trucks in 30 Years)

Design ESALs: (Total ESALs in 30 Years)

AASHTO Soil Classification:

Soil Modulus: (10,000 to 30,000 psi)

Aggregate Base Thickness: (0 to 10 in.)

HMA Modulus: (400,000 to 1,000,000 psi)

Calculated HMA in.

Design HMA in. Calculated thickness rounded up to nearest 0.25".



Perpetual Pavements & Maximum Thickness

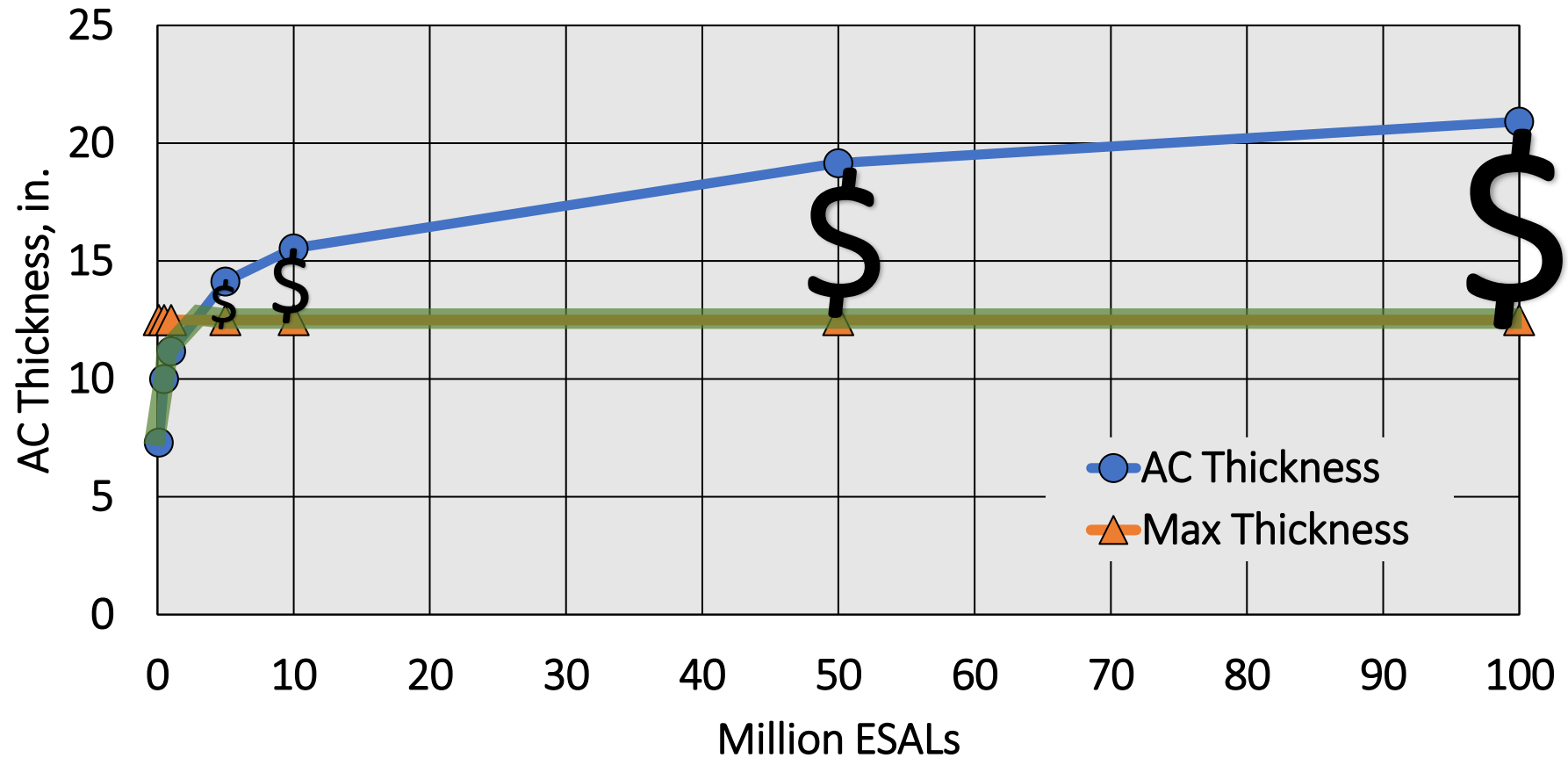

Perpetual Pavements – Practical Implementation

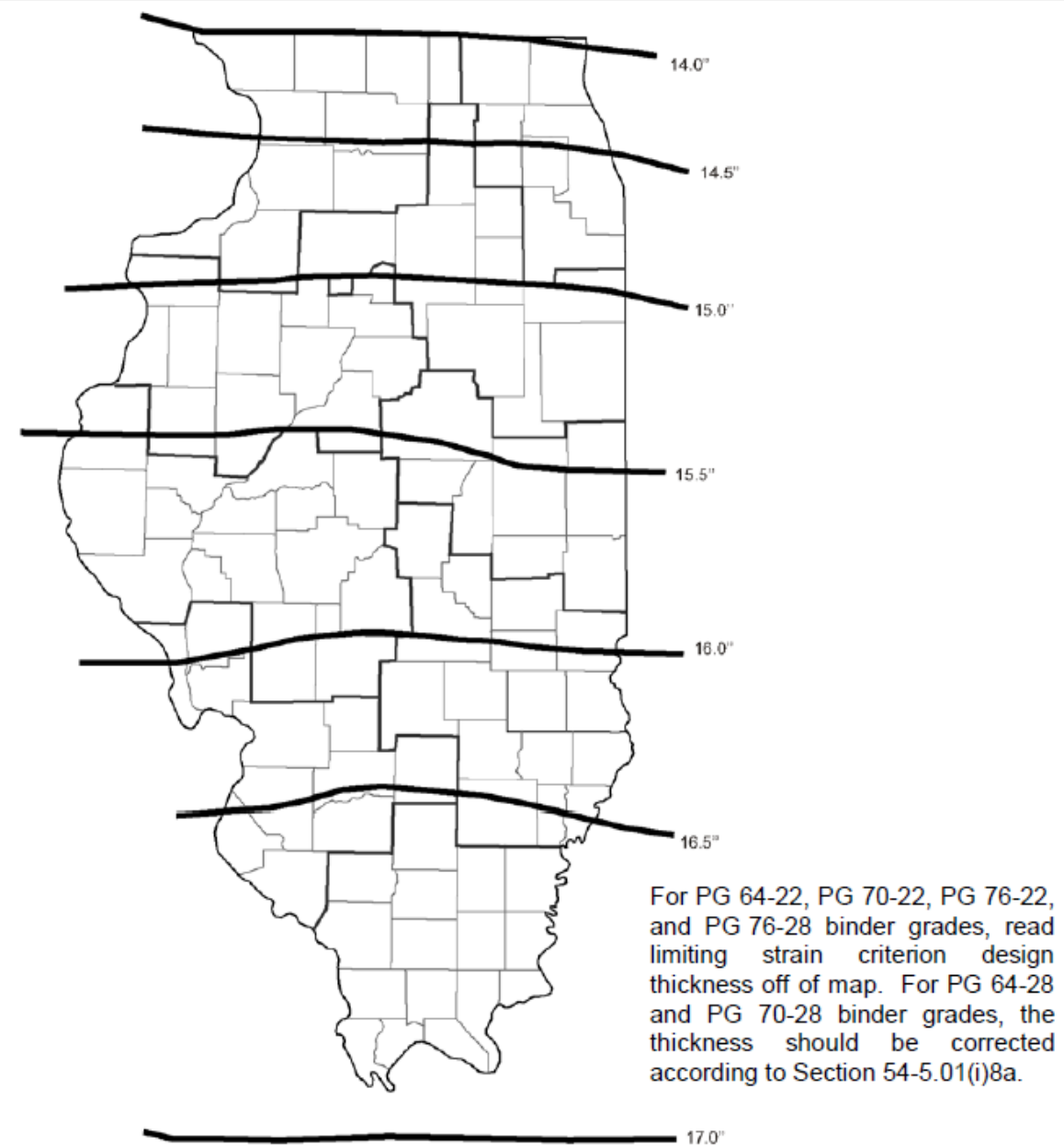

IDOT, 2010

Note. Thickness values based upon Mean Monthly Pavement Temperature at 4 in. depth correlated to July Mean Monthly Air Temperature, axle load of 20,000 lb, strain of $70 \mu\epsilon$, and E_{Ri} of 2 ksi.

Perpetual Pavements – Practical Implementation

Subgrade Mr (ksi)	Base Mr (ksi)	Calculated AC Thickness (in.)				Range of Maximum Thicknesses (in.)
		Minneapolis (PG 64-34)	Phoenix (PG 70-22)	Baltimore (PG 64-22)	Average	
5	30	12.5	15.5	14	14.0	12.5-15.5
5	50	12	15	14	13.7	12-15
5	100	12	14	13.5	13.2	12-14
10	30	10.5	14	12	12.2	10.5-14
10	50	10.5	13	12	11.8	10.5-13
10	100	10	12	11	11.0	10-12
20	30	9	12.5	10	10.5	9-12.5
20	50	8.5	12.5	9.5	10.2	8.5-12.5
20	100	8	12	9	9.7	8-12

Perpetual Pavements – Key Takeaways

- **Designed for long-term performance**
 - **Mechanistic–Empirical design is essential**
 - **Layered asphalt systems matter**
 - **Performance is proven in the field**
 - **Implementation is practical and achievable today**
- 

Thank you!





Illinois Tollway Perpetual Pavement Design Strategies

Bill Vavrik



INNOVATIVE SOLUTIONS
TO COMPLEX PROBLEMS

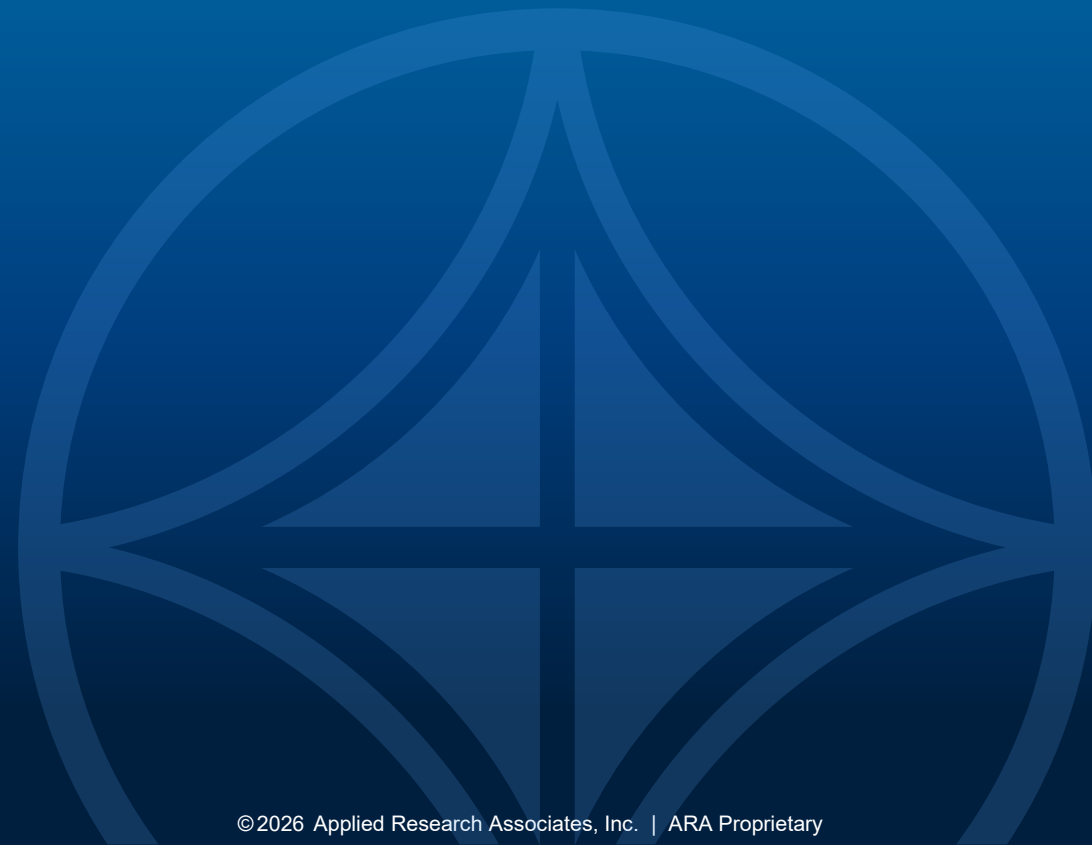



Design strategies to meet the local needs

- ▶ Knowing pavement conditions
- ▶ Knowing the pavement design inputs
- ▶ Understanding what is possible in perpetual pavement design
 - Staged construction
 - Rubblization
 - New construction

Must test and understand existing conditions



Must understand existing conditions











Traffic is a key pavement design input

- ▶ Truck Classification
- ▶ Counts & Locations
- ▶ Load Spectrum
- ▶ Basic Weight Impacts
 - Single & Multiple Unit



Daily Truck Traffic

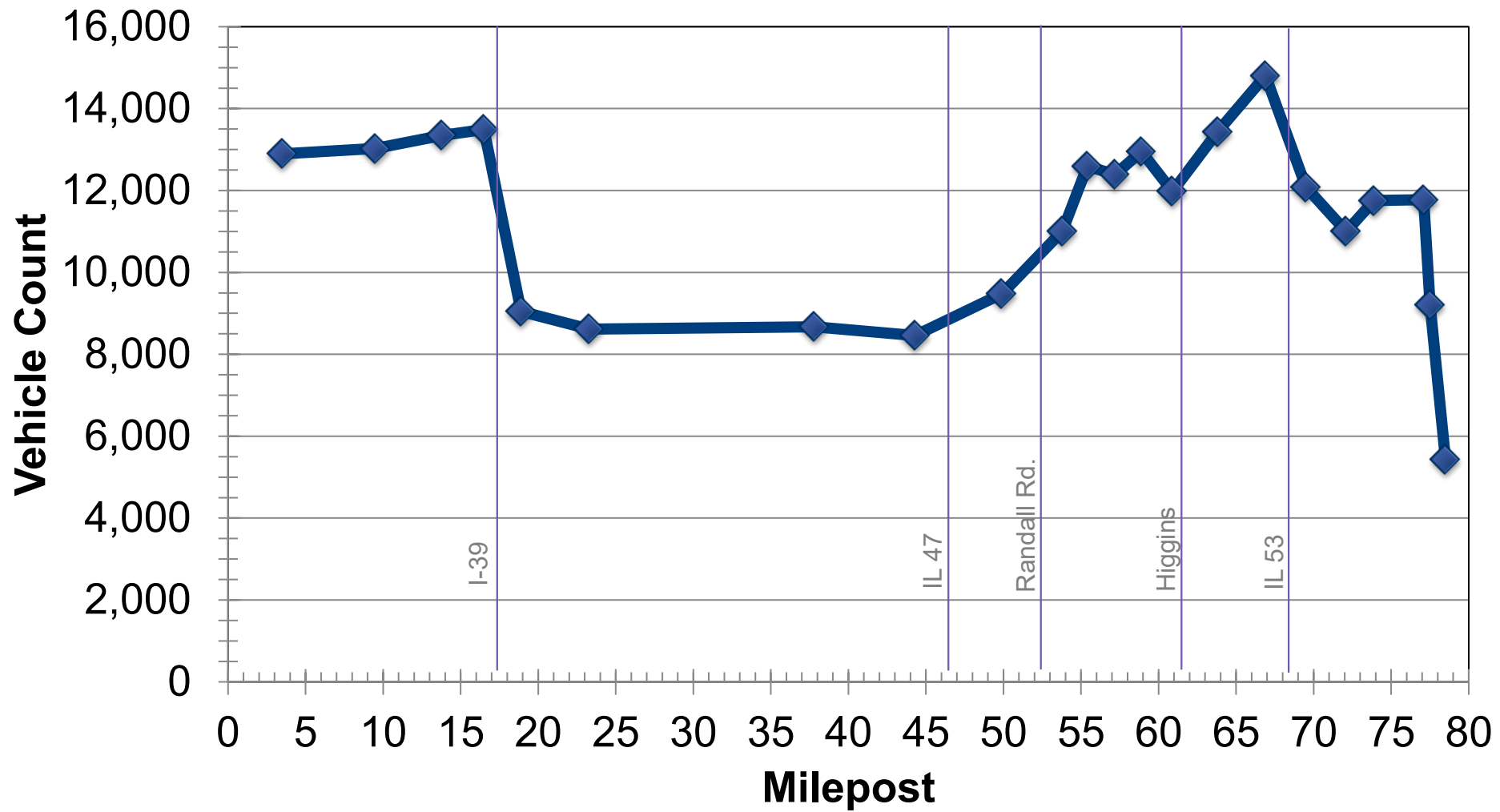



Tollway lane distribution does not generally follow national guidance

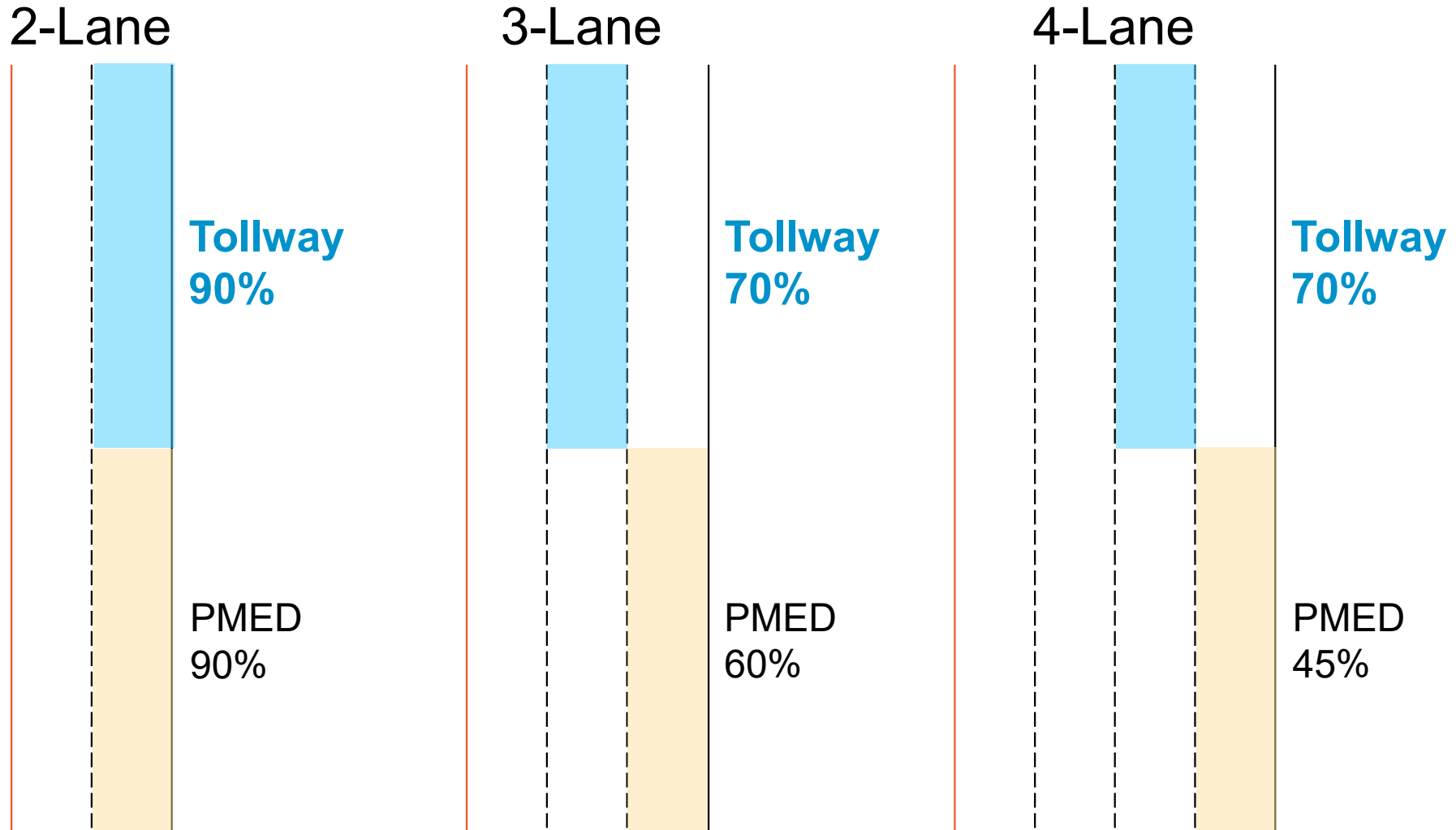



Current legal truck is the design truck

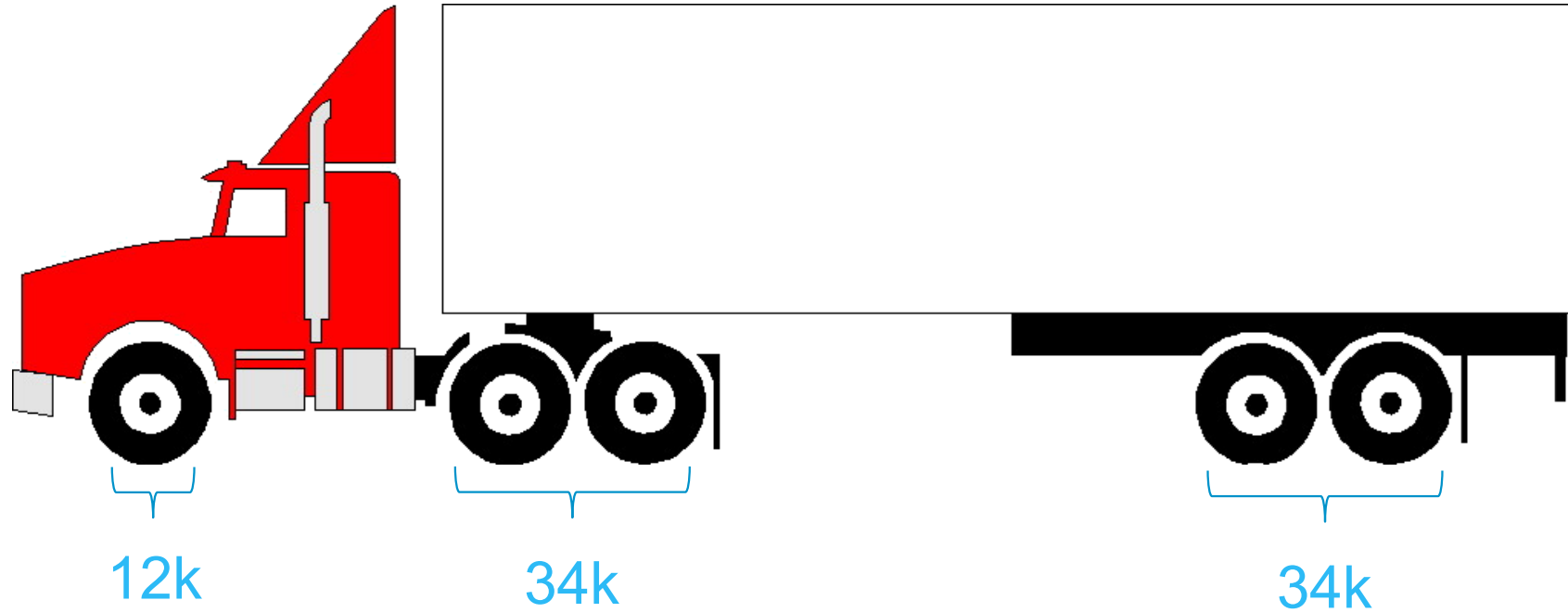



Tollway load spectra does not match national data

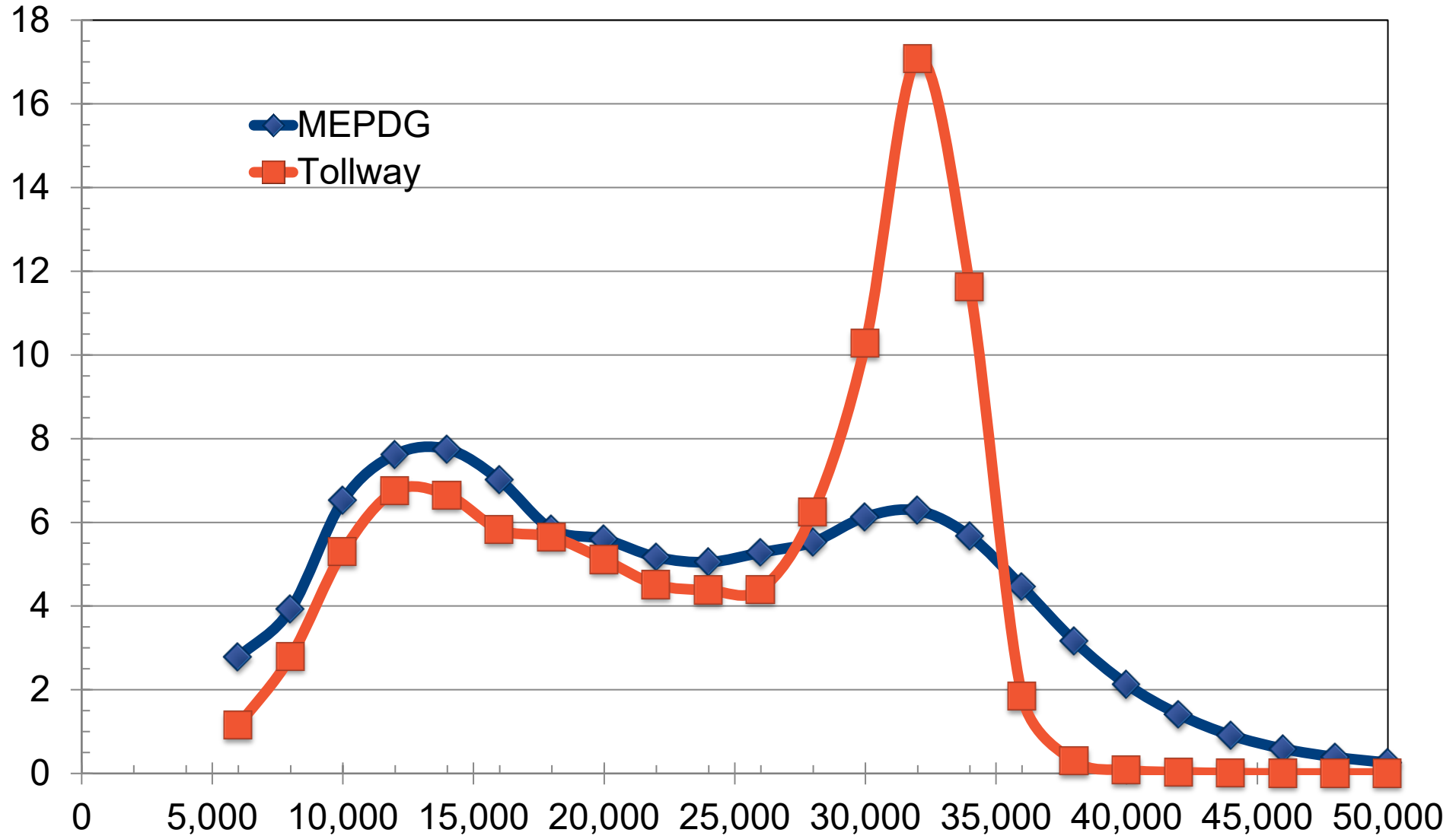

Added in larger truck weights for resilient design

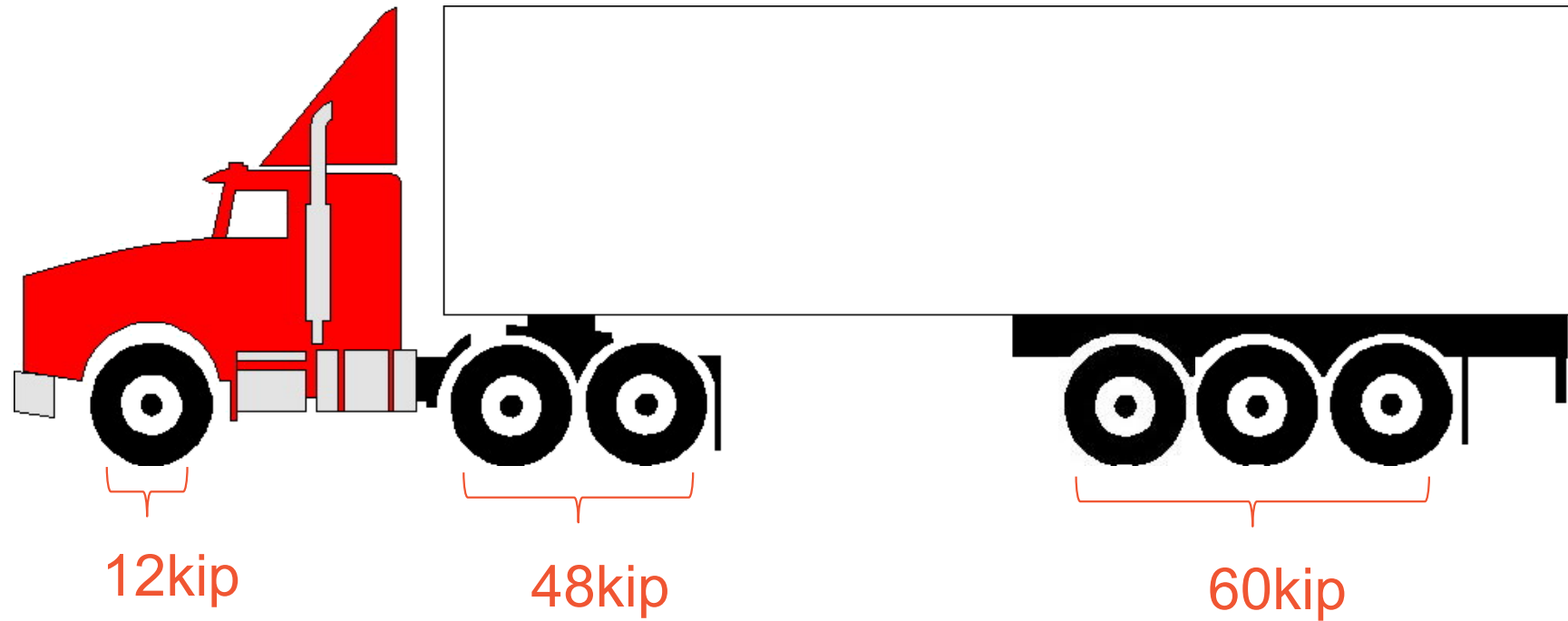



Staged Rubblization Pavement Design

▶ Innovative Design Approach

- Saves up-front construction cost
- Delays second stage of construction
 - What if traffic does not grow or shrinks?
 - Time-value of money

▶ The Concept

- Place 6.0" of polymer-modified HMA on top of the rubblized concrete
- In 10 years, remove 2.0" of HMA and place 6.0" HMA
 - During first 10 years, limited bottom-up damage occurs
- Net thickness of 10.0" of HMA on top of rubblized concrete



Monthly fatigue damage accumulation

	10-year Fatigue Damage % Updated IDOT Model	10-year Fatigue Damage % IDOT Rubblization Model
January	0.23%	0.66%
February	0.31%	0.87%
March	0.39%	1.07%
April	0.73%	1.83%
May	1.45%	3.35%
June	2.15%	4.73%
July	3.04%	6.41%
August	2.35%	5.10%
September	1.57%	3.59%
October	0.77%	1.92%
November	0.41%	1.12%
December	0.26%	0.75%
TOTAL	13.7%	31.4%



Rubblized concrete grew stiffer over time

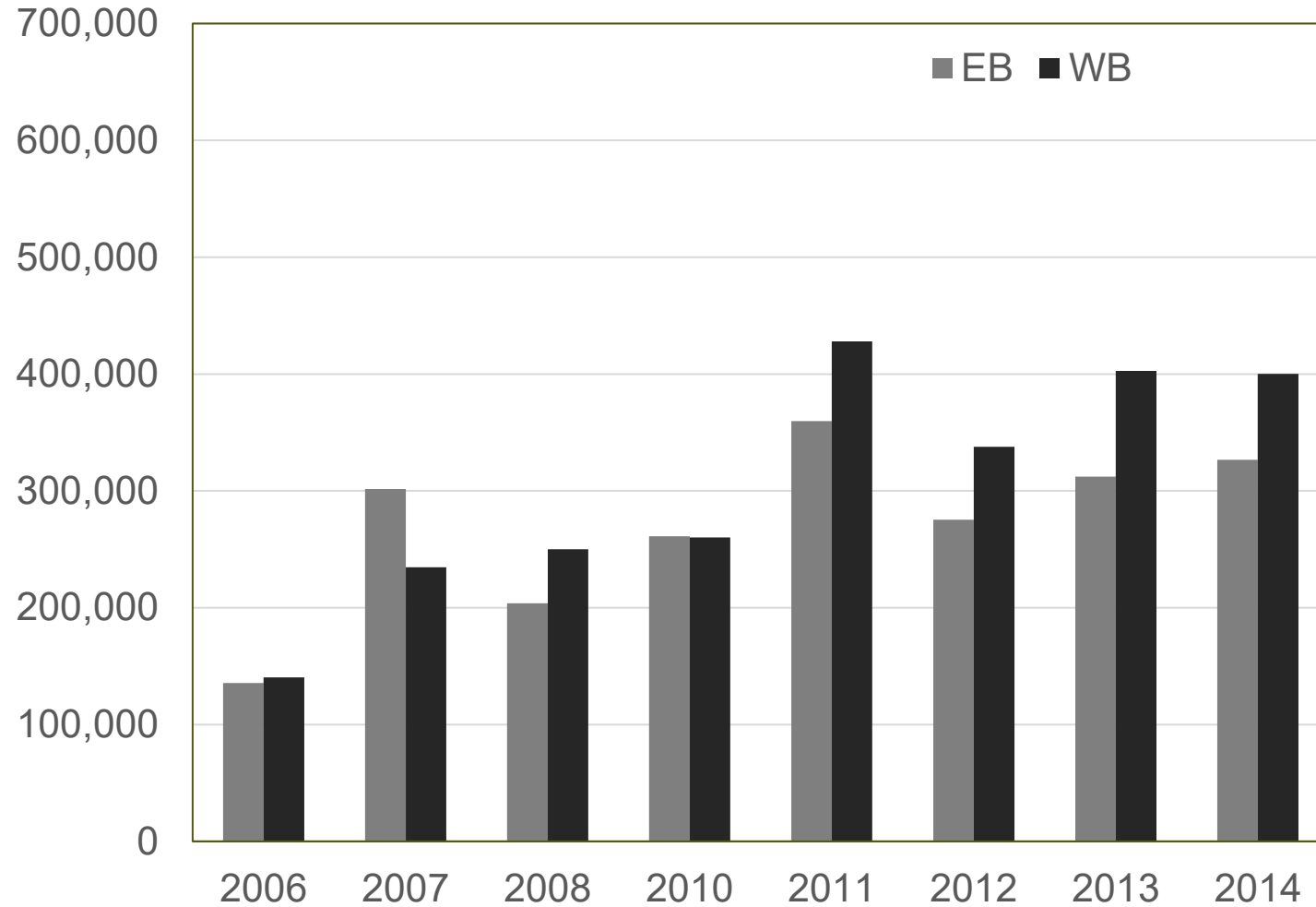



Asphalt modulus maintained stiffness

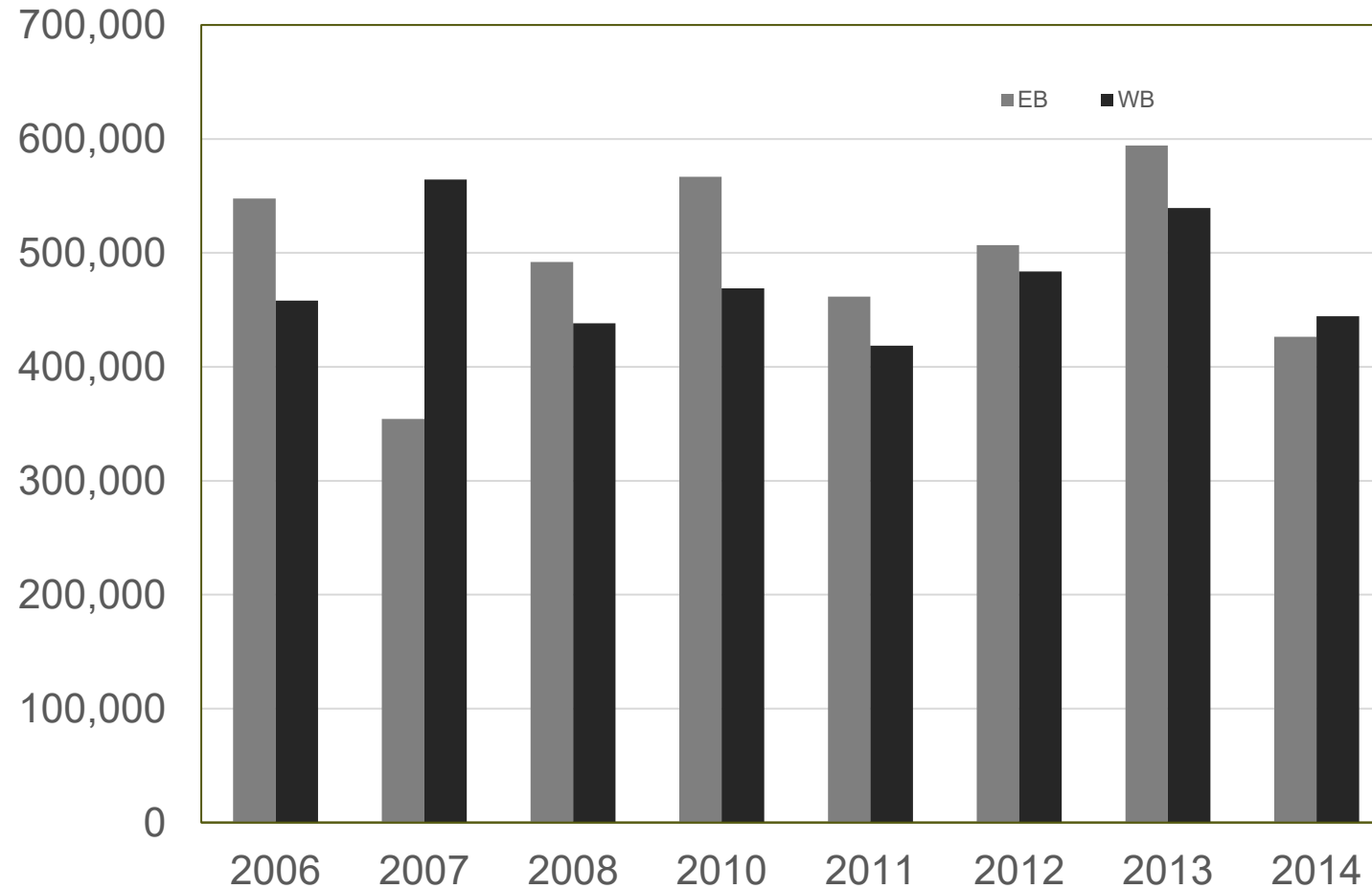

Calculated strain in the asphalt is low

Year	Eastbound Microstrains ($\mu\epsilon$, 10^{-6} in/in)	Westbound Microstrains ($\mu\epsilon$, 10^{-6} in/in)
2006	71.8	74.0
2007	40.3	47.7
2008	54.9	47.2
2010	43.7	45.2
2011	33.7	28.4
2012	20.4	35.6
2013	37.4	30.0
2014	37.1	22.6

Expected to need strain less than 70 microstrain ($\mu\epsilon$, 10^{-6} in/in)



Illinois Tollway designs for long and resilient life

- ▶ Understand existing conditions
- ▶ Use pavement design inputs that meet current and potential future
- ▶ Allow innovation in materials
 - Optimize material properties for where they are used in the pavement

- ▶ Staged construction – It works!

- ▶ Rubbilization – It works!

- ▶ New construction – It works!

Perpetual pavements for airfields

Designing for Performance in Perpetual Asphalt Pavements

Presented to: TRB Webinar

By: Navneet Garg, Ph.D., F.ASCE

Date: March 19, 2026

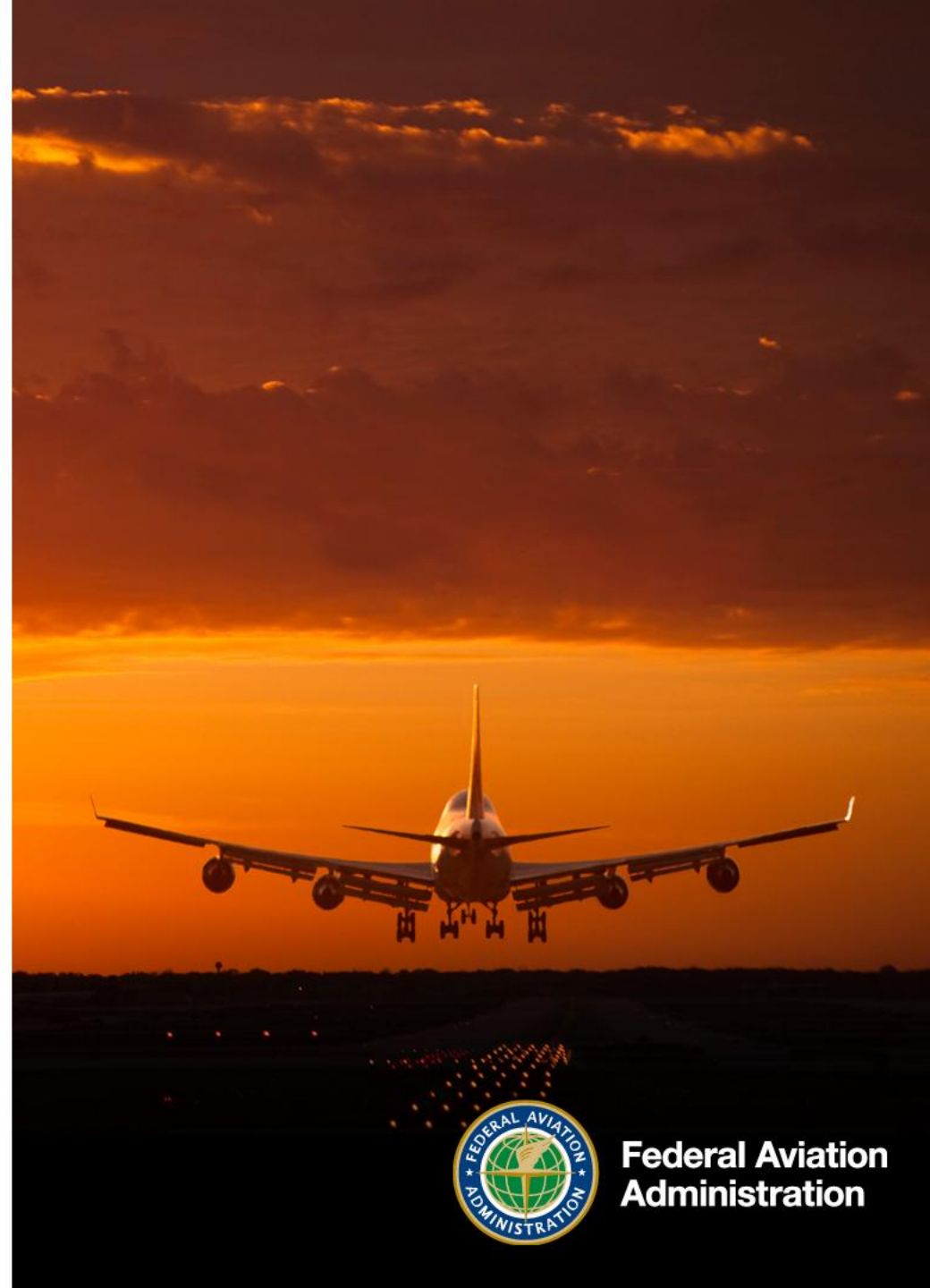

Outline

- **Introduction**
- **Objectives**
- **Airport Pavement Design**
- **Full-Scale Tests at NAPTF – CC7 & CC9**
- **Summary**



Civil Aviation & Loading Characteristics

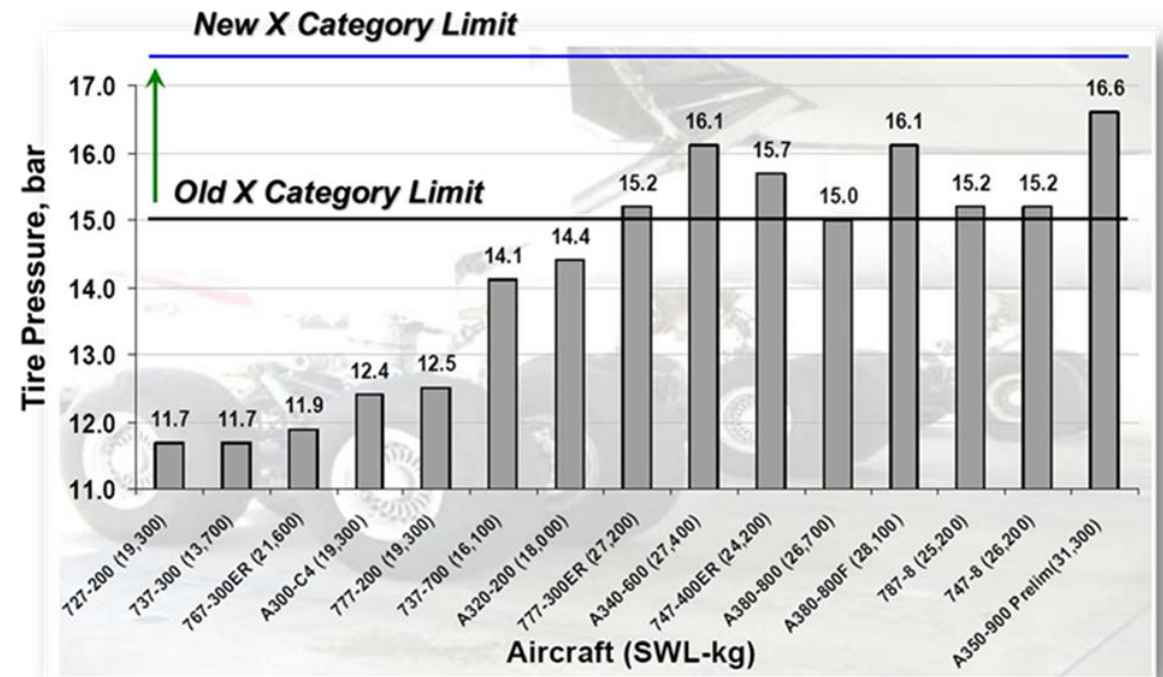
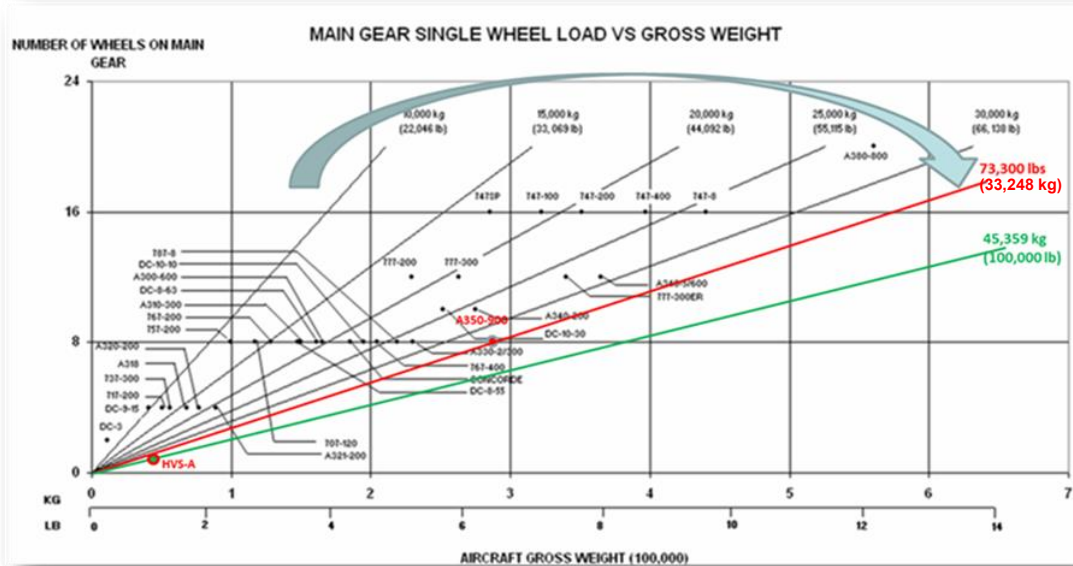



- Research conducted at the FAA William J. Hughes Technical Center, Atlantic City, NJ, USA.
- Sponsor: FAA Office of Airport Safety and Standards (AAS110), Washington, DC.
- Provide support for development of FAA pavement standards (Advisory Circulars).

National Airport Pavement Test Facility (NAPTF)

FAA Full-Scale Test Facilities

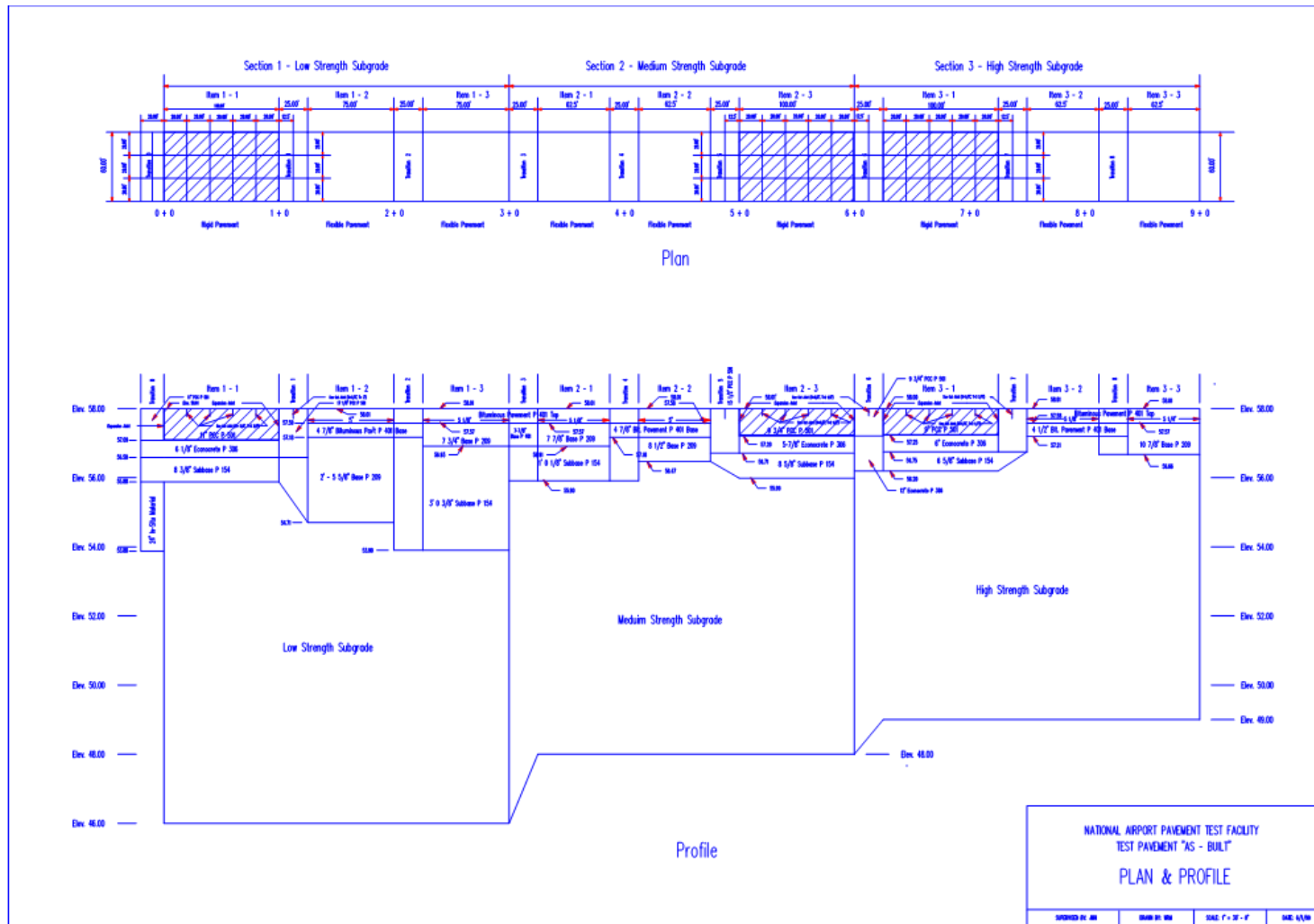

Outline

- Introduction
- **Objectives**
- Airport Pavement Design
- Full-Scale Tests at NAPTF – CC7 & CC9
- Summary



Objectives

- Develop Perpetual Pavements Design criterion for airport pavements.
- Vertical strain threshold in the HMA layer to limit rutting.
- Horizontal strain threshold in the HMA base layer to prevent bottom-up fatigue cracking.
- Relationship between laboratory fatigue strain threshold and measured field HMA strains.
- Study strain distribution in the HMA layer.
- Verify/Refine/Modify fatigue model based on the ratio of dissipated energy change (RDEC)

Outline

- Introduction
- Objectives
- **Airport Pavement Design**
- Full-Scale Tests at NAPTF – CC7 & CC9
- Summary

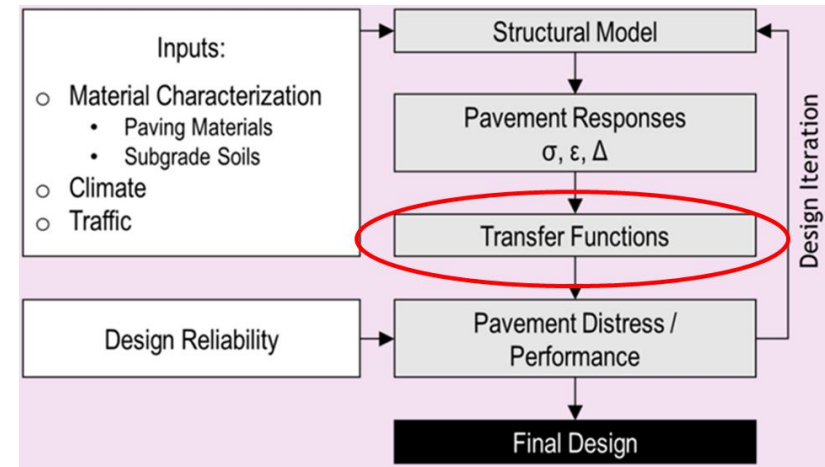

Design Charts – FAA AC 150/5320-6D

7/7/95

AC 150/5320-6D

- Airport Pavement Design and Evaluation (1995)
- Contained nomographs for single-wheel, dual, dual-tandem and specific large aircraft (including B747).

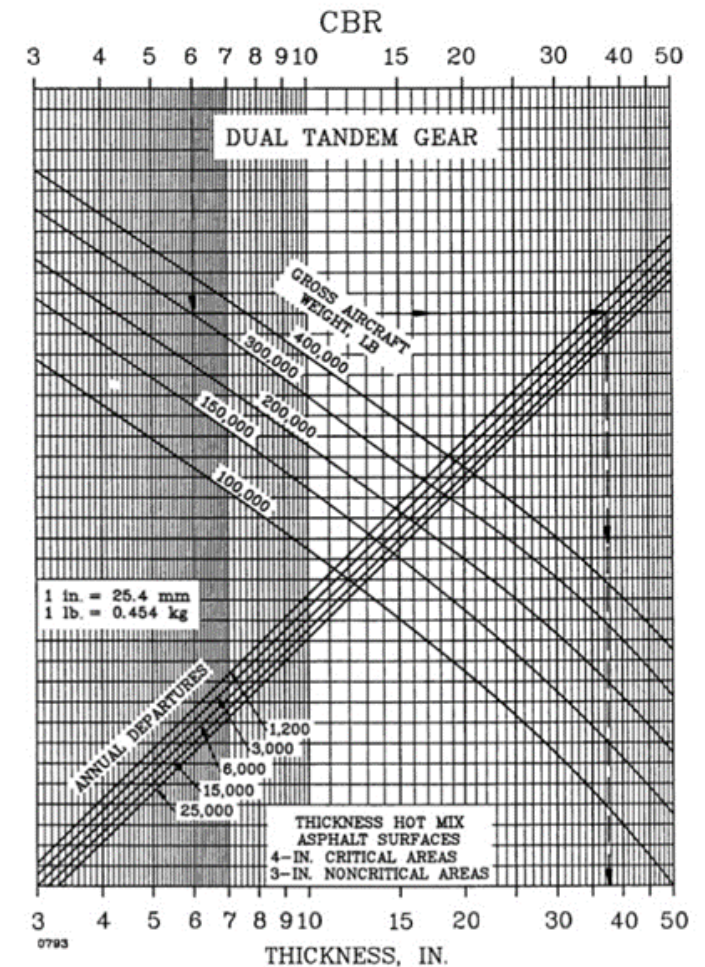

FIGURE 3-4 FLEXIBLE PAVEMENT DESIGN CURVES, DUAL TANDEM GEAR

FAARFIELD 2.0

The screenshot shows the FAARFIELD 2.0 software interface. Key components are labeled with callout boxes:

- EXPLORER**: Points to the left-hand navigation pane.
- TOOLBAR**: Points to the top menu bar.
- FUNCTION SELECTION**: Points to the 'Run' button in the top toolbar.
- RUN**: Points to the 'Run' button in the top toolbar.
- OPTIONS**: Points to the 'Design Options' dialog box on the right.
- HELP**: Points to the 'Help' button in the top toolbar.
- PAVEMENT TYPE SELECTION**: Points to the 'Pavement Type' dropdown menu.
- STRUCTURE TABLE**: Points to the table listing pavement layers and their properties.
- STRUCTURE IMAGE**: Points to the 3D visualization of the pavement structure.
- MATERIAL LIBRARY TAB**: Points to the 'Material' tab in the bottom navigation.
- AIRCRAFT LIBRARY TAB**: Points to the 'Aircraft' tab in the bottom navigation.
- TRAFFIC TABLE**: Points to the 'Traffic' table at the bottom of the interface.

Material	Thickness (in)	E (psi)	CBR
P-401/P-403 HMA Surface	4.0	200000	
P-401/P-403 HMA Stabilized	5.0	400000	
P-209 Crushed Aggregate	10.0	75000	10
Subgrade		15000	

Airplane Name	Gross Taxi Weight (lbs)	Annual Departures	Annual Growth (%)	Total Departures	CDF Contributions	CDF Max for Airplane	P/C Ratio	Tire Pressure (psi)	Percent GW on Gear	Dual Spacing (in)	Tandem Tire Spacing (in)	Tire Contact Width (in)	Tire Contact Length (in)
A319-100 std	141978	1200	0	240000	0	0	0	173	47.50%	36.5	0.0	12.5	19.9
B737-300	140000	12000	0	240000	0	0	0	201	47.50%	30.5	0.0	11.5	18.4
B747-400	877000	500	0	100000	0	0	0	200	23.75%	44.0	58.0	14.4	23.0
B747-400 Belly	877000	500	0	100000	0	0	0	200	23.75%	44.0	58.0	14.4	23.0
B787-8	503500	6500	0	130000	0	0	0	228	47.50%	51.0	57.5	14.4	23.1

Main program drives four subprograms:
 LEAF (layered elastic analysis)
 FAAMesh (3D mesh Generation)
 FAASR3D (3D finite element analysis)
 ICAO-ACR (Aircraft Classification Rating)

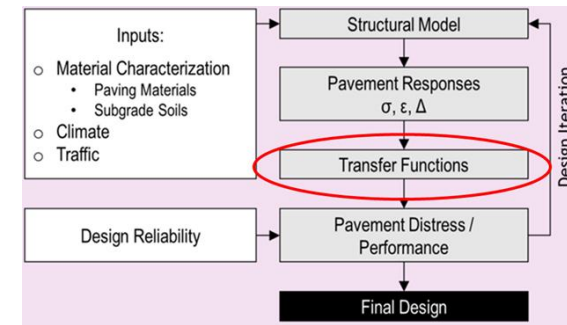

Failure Models in FAARFIELD

- This is the “empirical” part of mechanistic-empirical.
 - Derived from full-scale traffic tests at NAPTF and previous APT.
 - Relates strain or stress to allowable coverages (fatigue).
 - Tied to CDF through P/C ratio.
- Flexible:
 - For subgrade rutting, the failure model is based on limiting the vertical strain on top of subgrade.

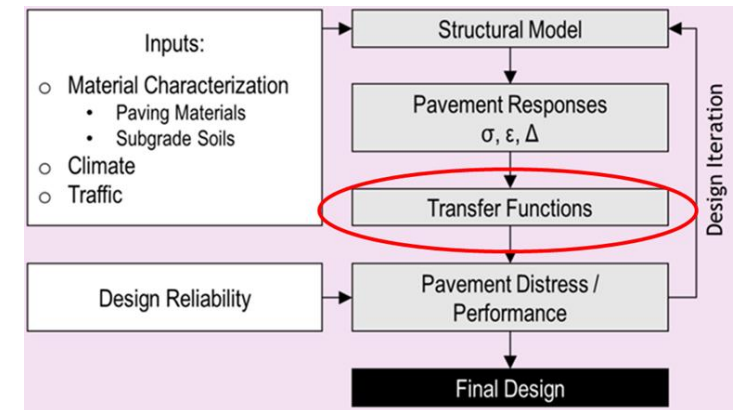

$$\log_{10} (C) = \left(\frac{1}{-0.1638 + 185.19 \times \varepsilon_v} \right)^{0.60586}, \text{ when } C > 1000 \text{ coverages; and}$$

$$C = \left(\frac{0.004141}{\varepsilon_v} \right)^{8.1}, \text{ when } C \leq 1000 \text{ coverages}$$

C = number of coverages to failure

ε_v = vertical strain at the top of the subgrade

HMA Fatigue - FAARFIELD

- Old HMA Fatigue Model: Heukelom & Klomp [1962]

$$\log_{10}(C) = 2.68 - 5 \times \log_{10}(\varepsilon_h) - 2.665 \times \log_{10}(E_A)$$

Coverage (C) - one coverage occurs when a unit area of the pavement experiences the maximum response (stress for rigid pavement, strain for flexible pavement) induced by a given airplane



HMA Fatigue - FAARFIELD

– New HMA Fatigue Model: Carpenter et.al. [1997, 2000, 2001, 2007]

$$N_f = 0.4801 \times PV^{-0.9007}$$

$$PV = 44.422 \times \varepsilon_h^{5.14} \times S^{2.993} \times VP^{1.85} \times GP^{-0.4063}$$

where PV is the estimated value of RDEC
plateau value (dimensionless),
S is HMA flexural stiffness (psi),
 ε_h is horizontal strain at the bottom of the asphalt layer,
VP is the volumetric parameter, and
GP is gradation parameter.

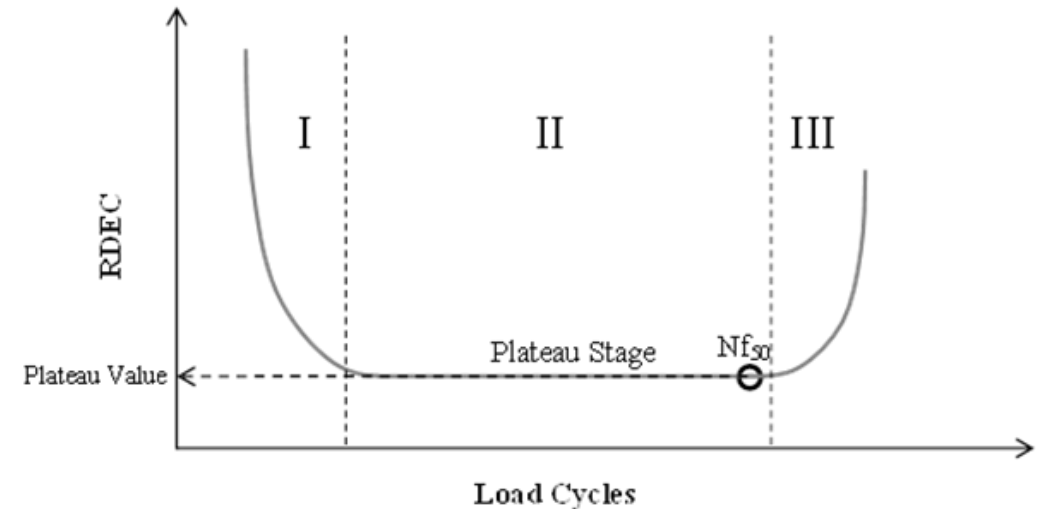

HMA Fatigue - FAARFIELD

$$VP = V_a / (V_a + V_b)$$

$$GP = (P_{NMS} - P_{PCS}) / P_{200}$$

where

V_a is air voids,

V_b is asphalt content by volume,

P_{NMS} is the % of aggregate passing the nominal maximum size sieve,

P_{PCS} is the % of aggregate passing the primary control sieve, and

P_{200} is the % of aggregate passing the #200 (0.075 mm) sieve.

Outline

- Introduction
- Objectives
- Airport Pavement Design
- **Full-Scale Tests at NAPTF – CC7 & CC9**
- Summary



CC-7 Perpetual Pavements

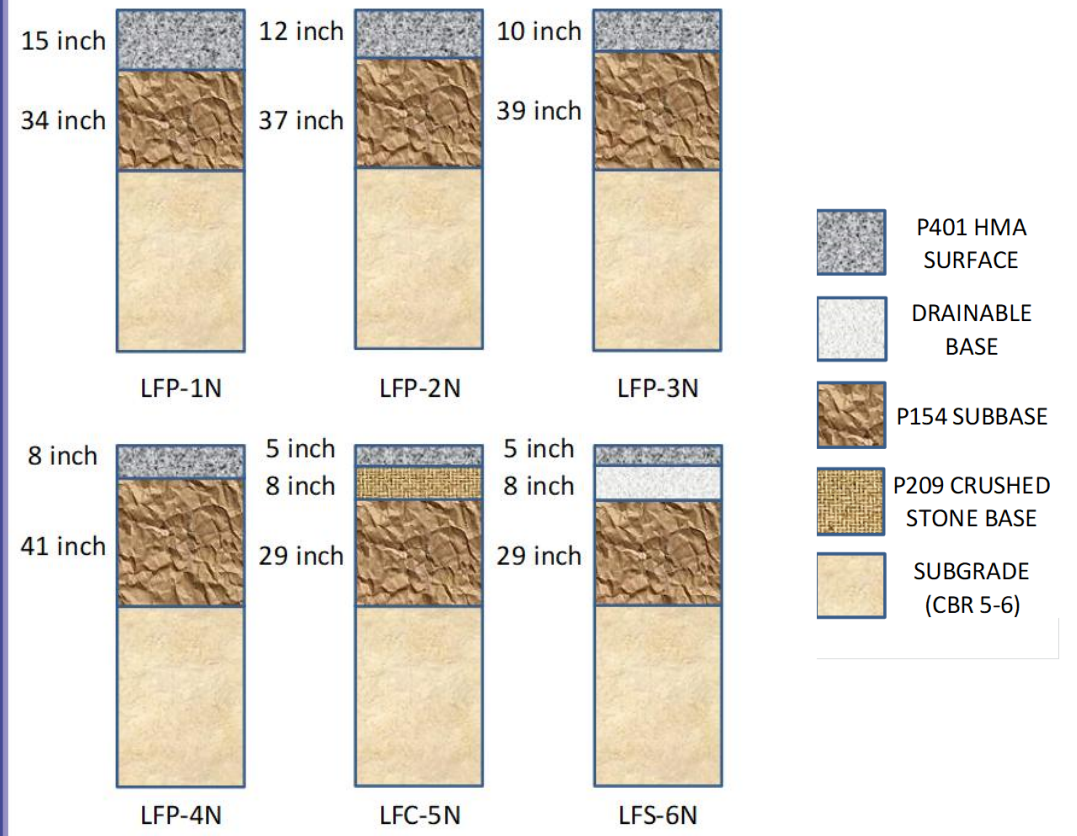
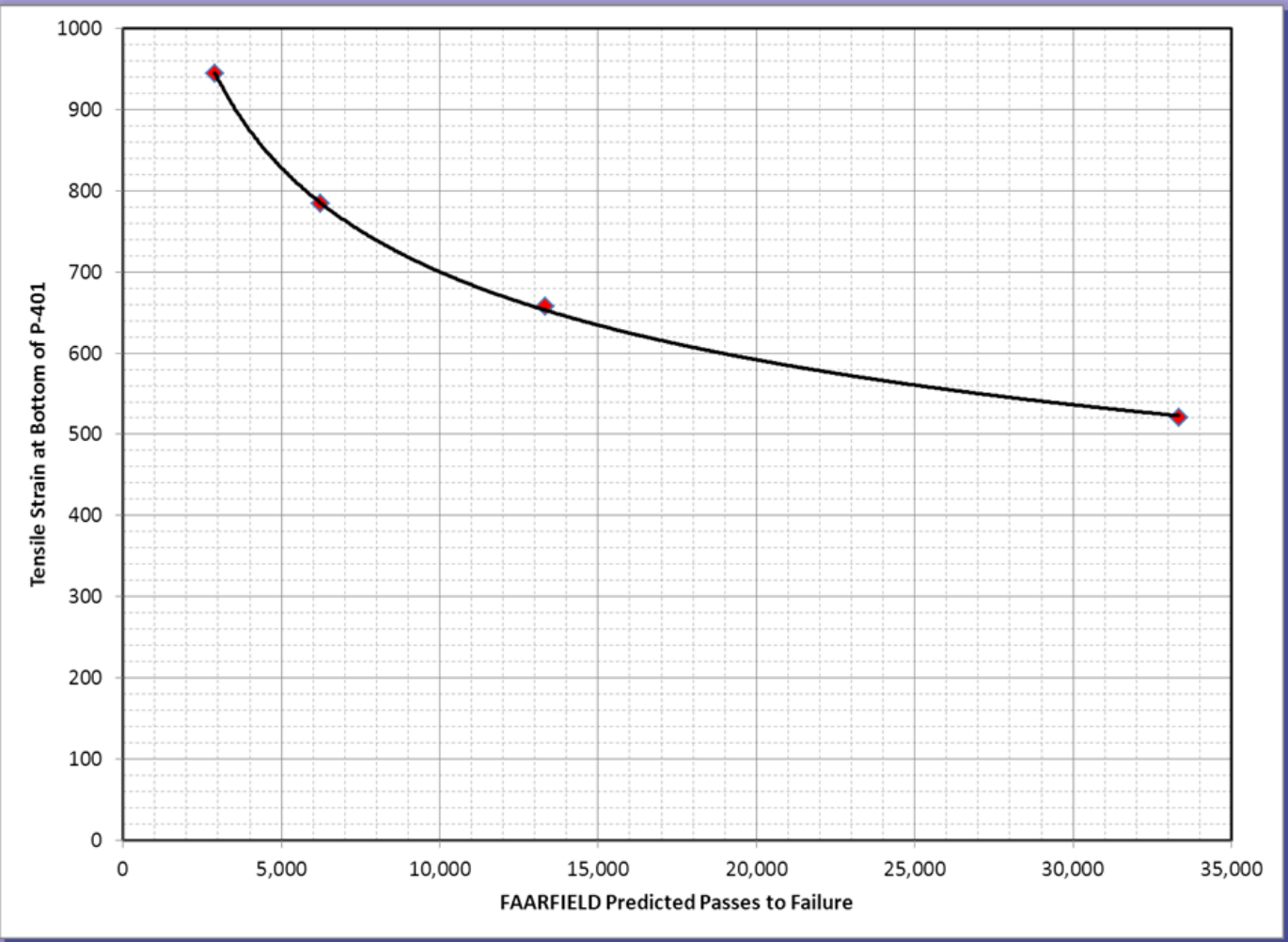

CC-7 Pavement Instrumentation

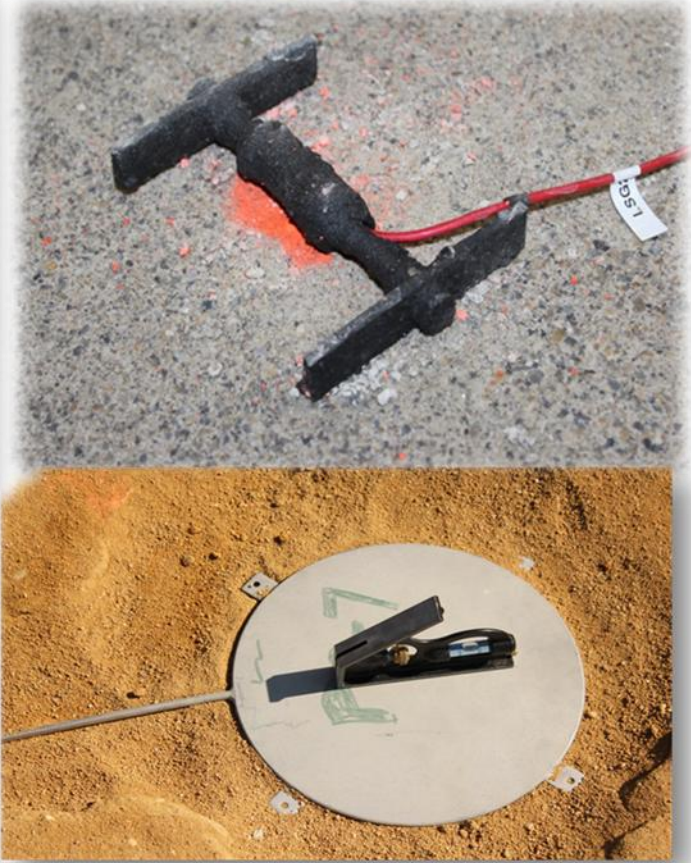

CC-7 Fiber Optic Strain Plate

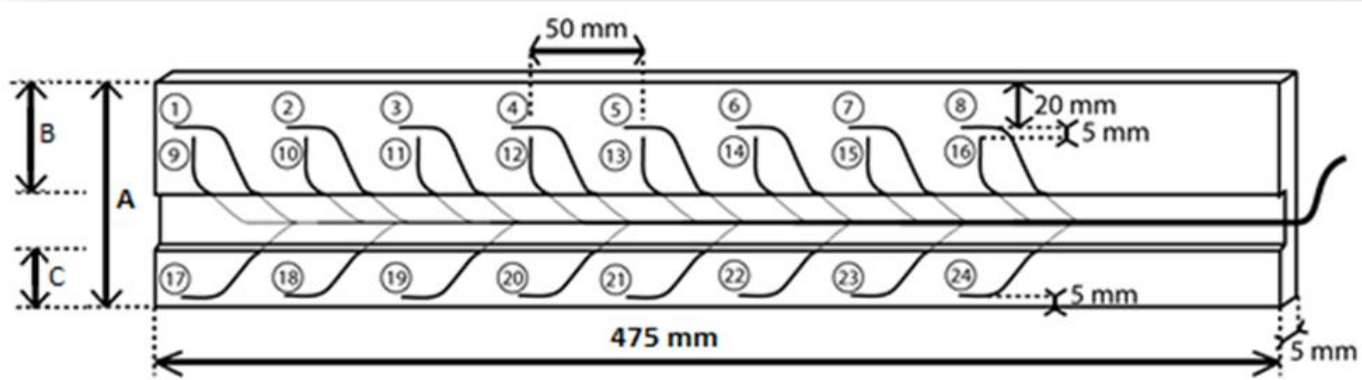

8" AC : A=203 mm / B=101.5 mm / C = 76.5 mm 10" AC : A=254 mm / B=127 mm / C=102 mm
 12" AC : A=305 mm / B=152.5 mm / C = 127.5 mm 15" AC : A=381 mm / B=190.5 mm / C=165.5 mm

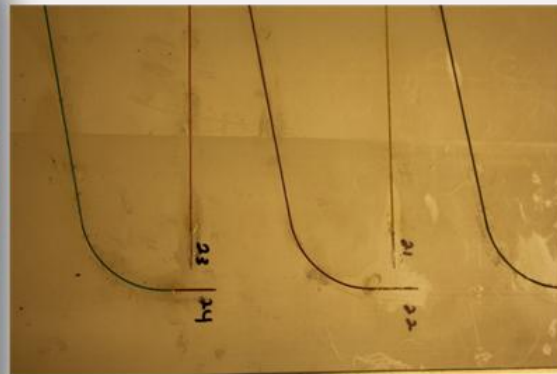
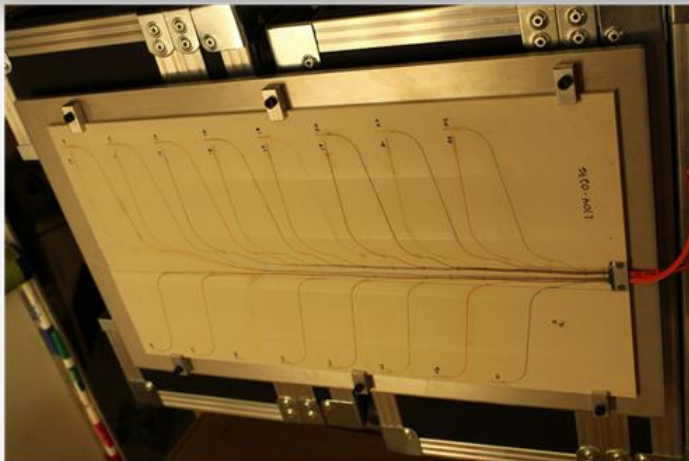

CC-7 Traffic Tests

			63 & 64	65 & 66	61 & 62			
		51 & 52	59 & 60	53 & 54	57 & 58	55 & 56		
19 & 20	43 & 44	45 & 46	41 & 42	47 & 48	39 & 40	49 & 50	37 & 38	
1 & 2	35 & 36	21 & 22	33 & 34	23 & 24	31 & 32	25 & 26	29 & 30	27 & 28
	17 & 18	3 & 4	15 & 16	5 & 6	13 & 14	7 & 8	11 & 12	9 & 10
-4	-3	-2	-1	0	1	2	3	4

Standard NAPTF wander pattern

55 kips (245 kN) wheel load
6-wheel gear

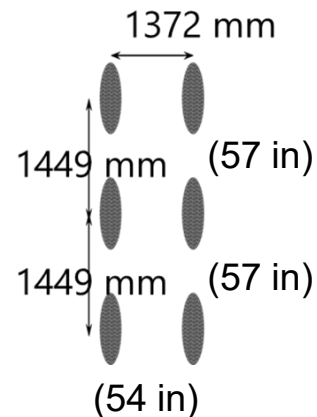

Pavement Monitoring

- Straight Edge Rut Depth Measurements
- Surface profiles
- Crack maps

CC-7 Vertical Strains in HMA

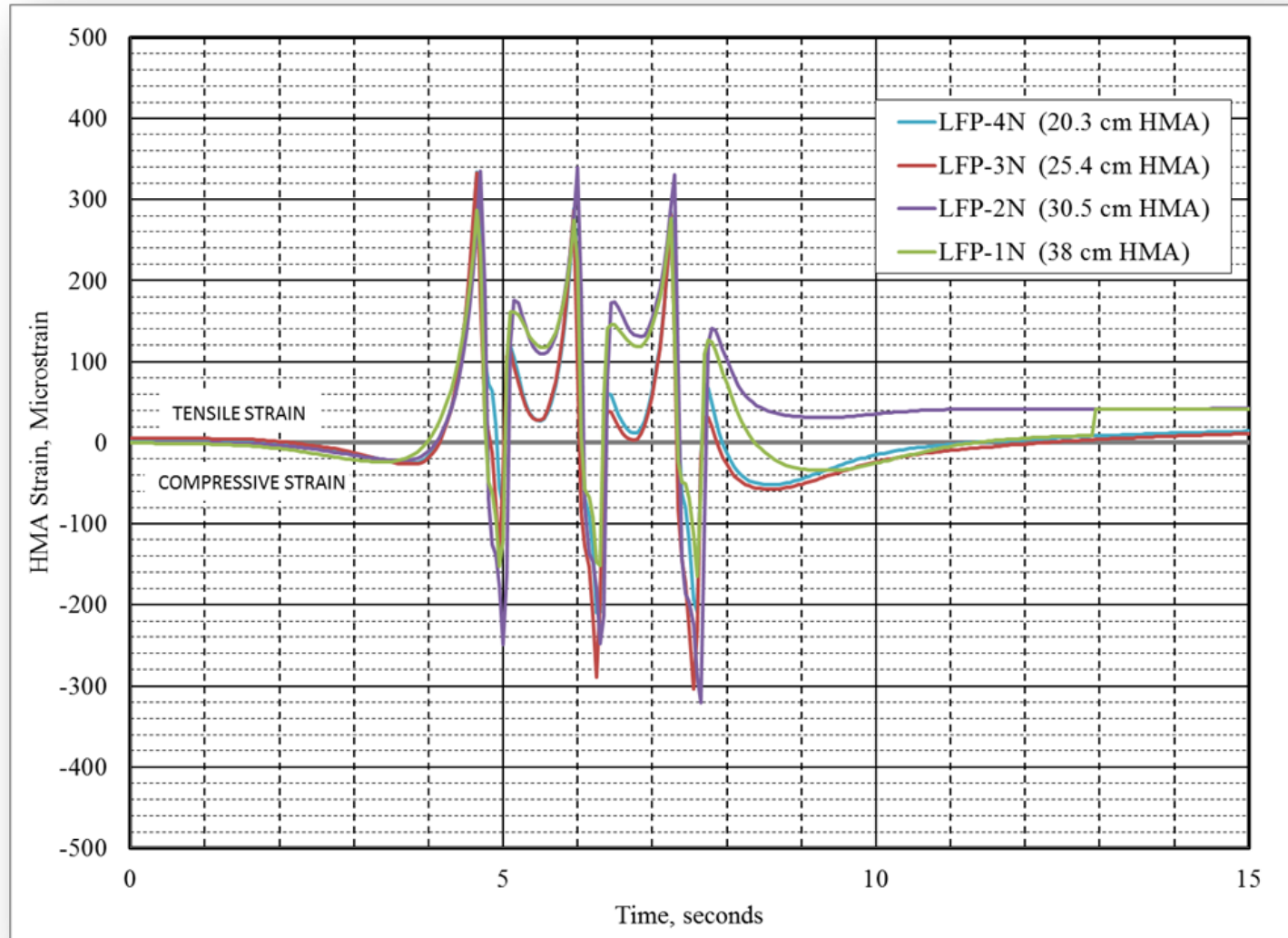

CC-7 Transverse Strains at HMA Surface

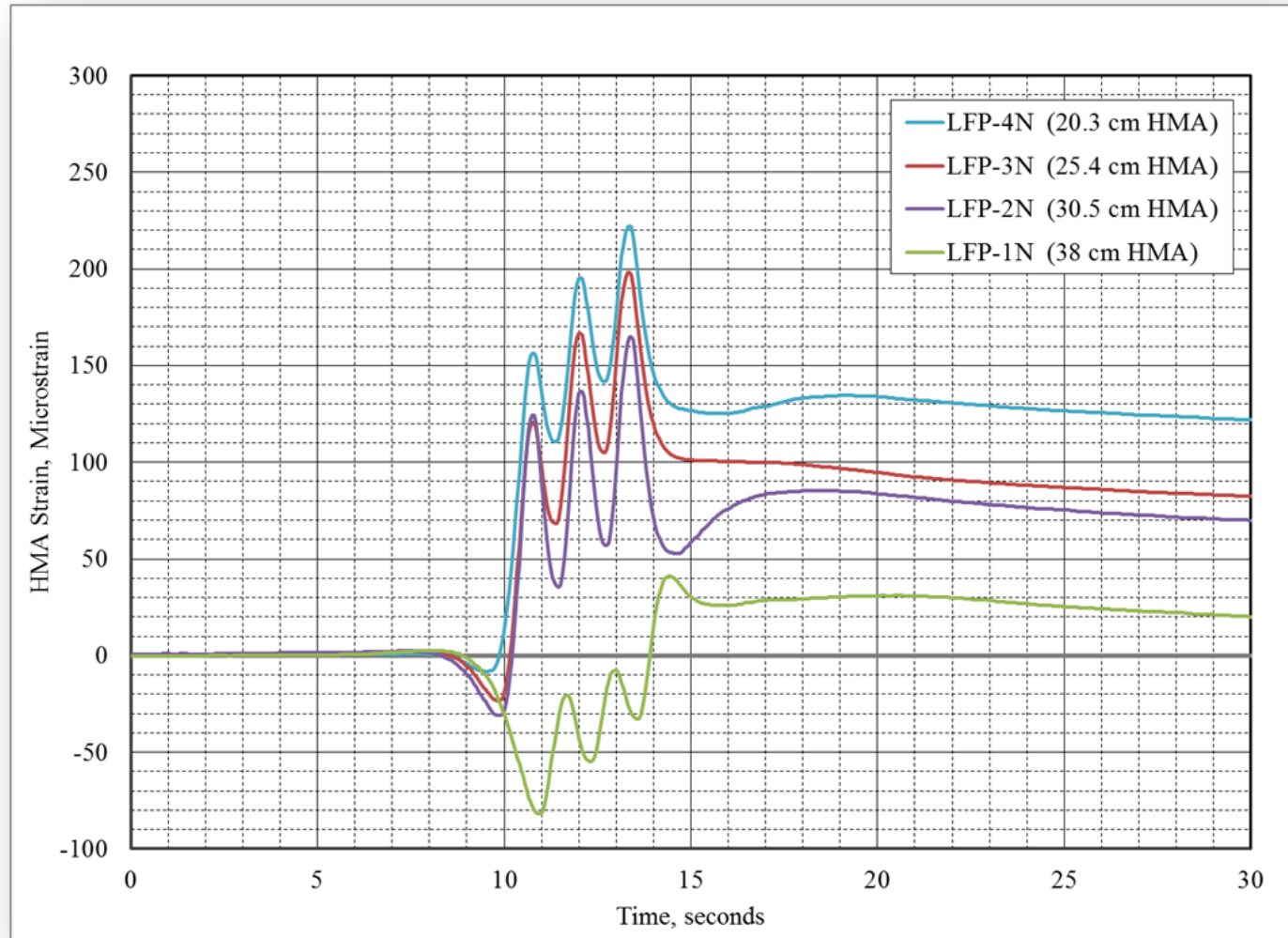

CC-7 Transverse Strains at Bottom of HMA

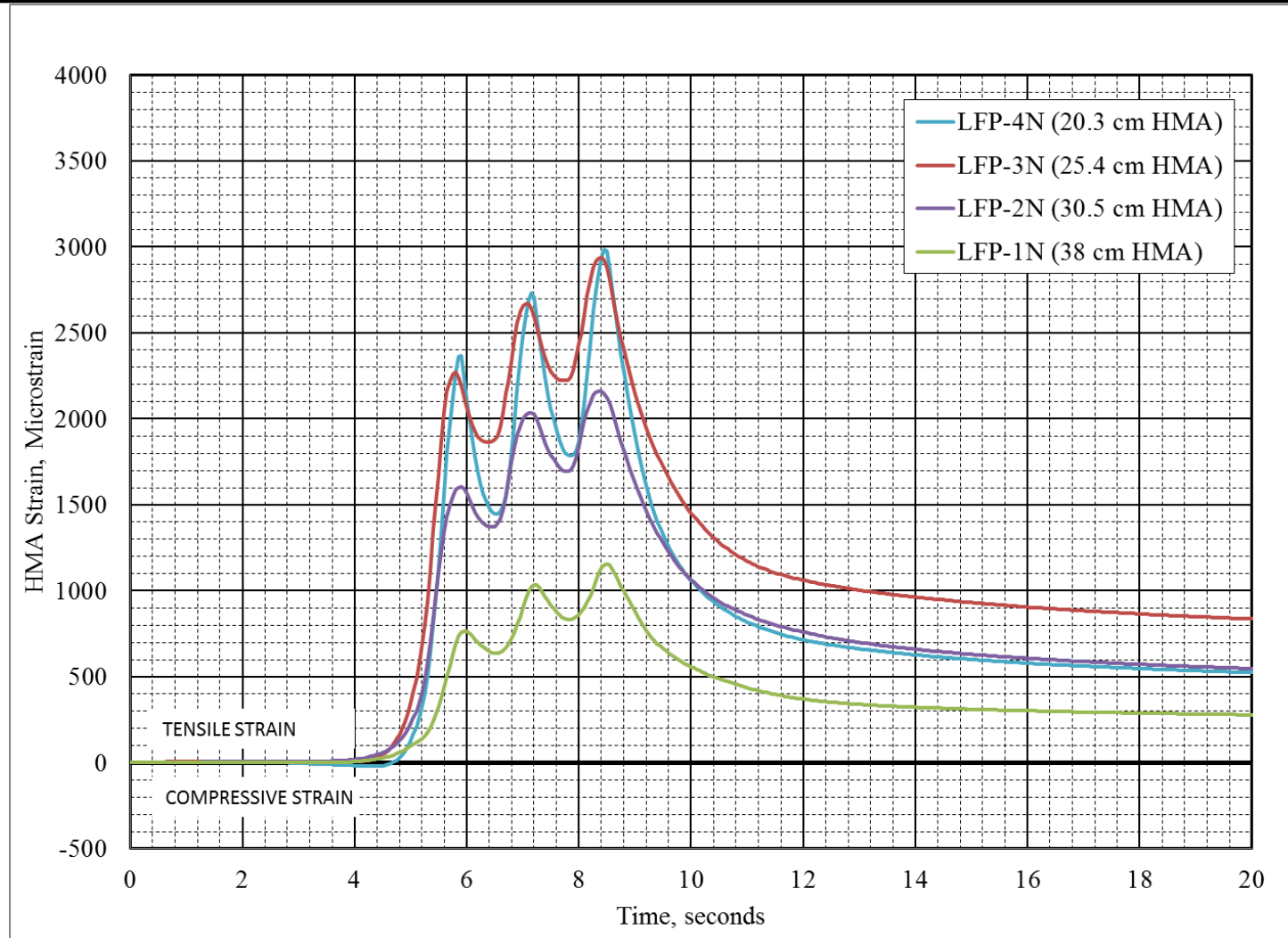

CC-7 Straight Edge Rut Depth Measurements

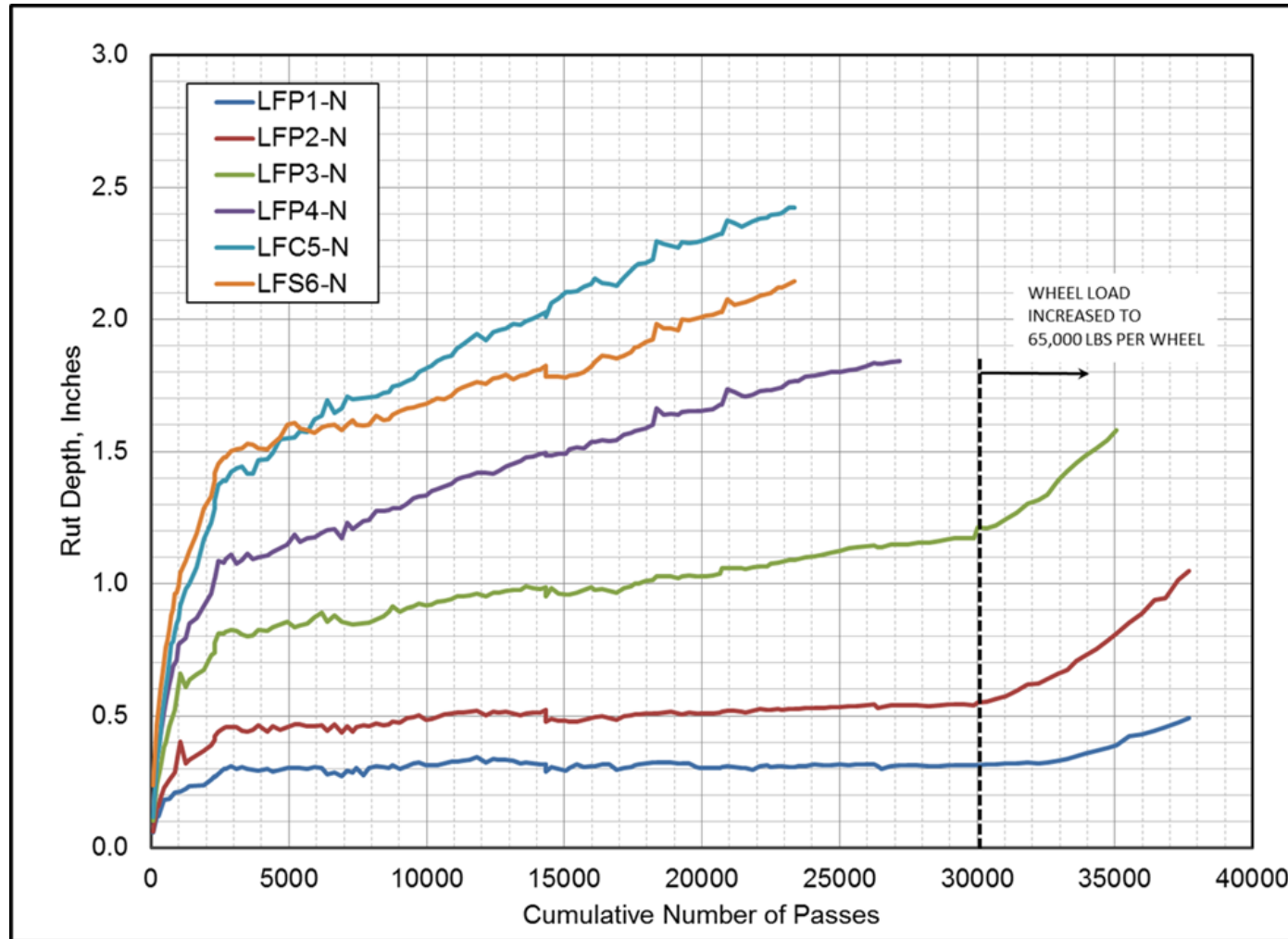

CC-7 Crack Monitoring

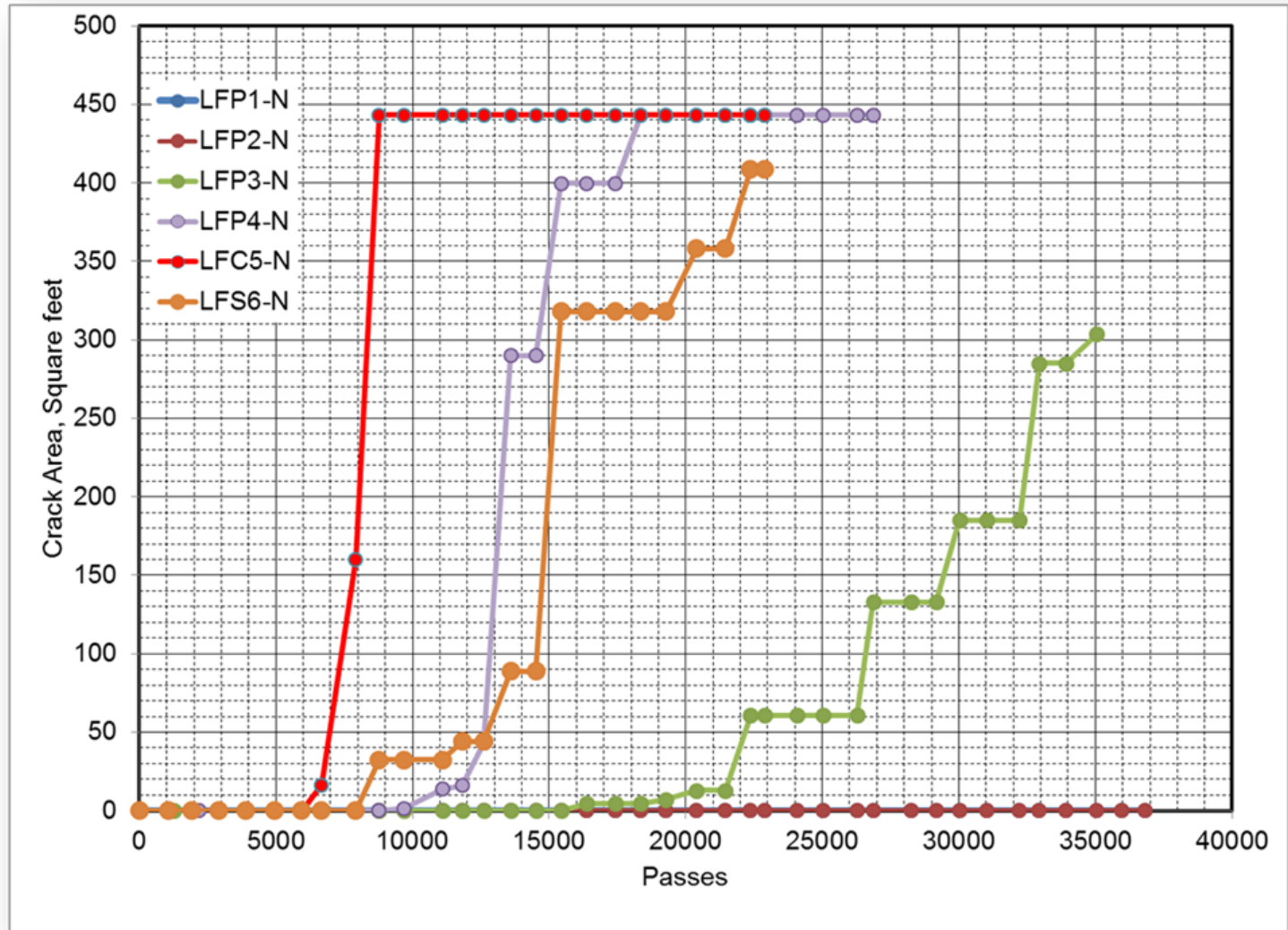

CC-7 Transverse Strains at Bottom of HMA (H-Bar)

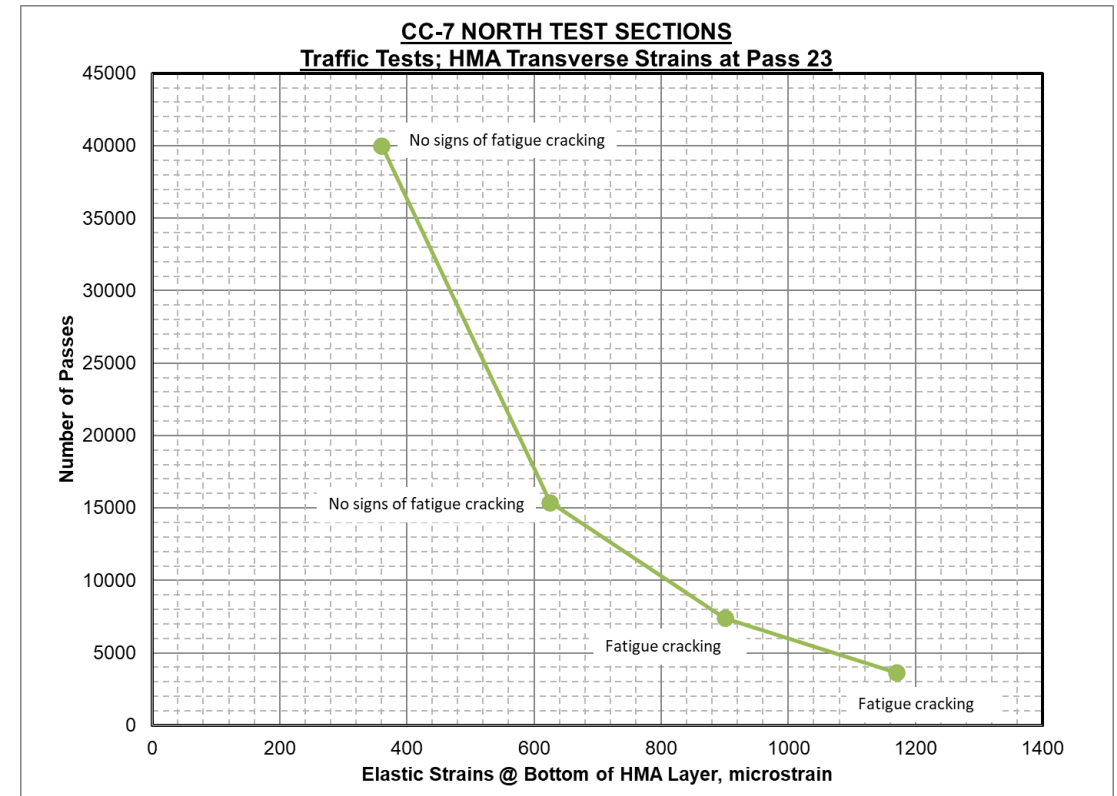
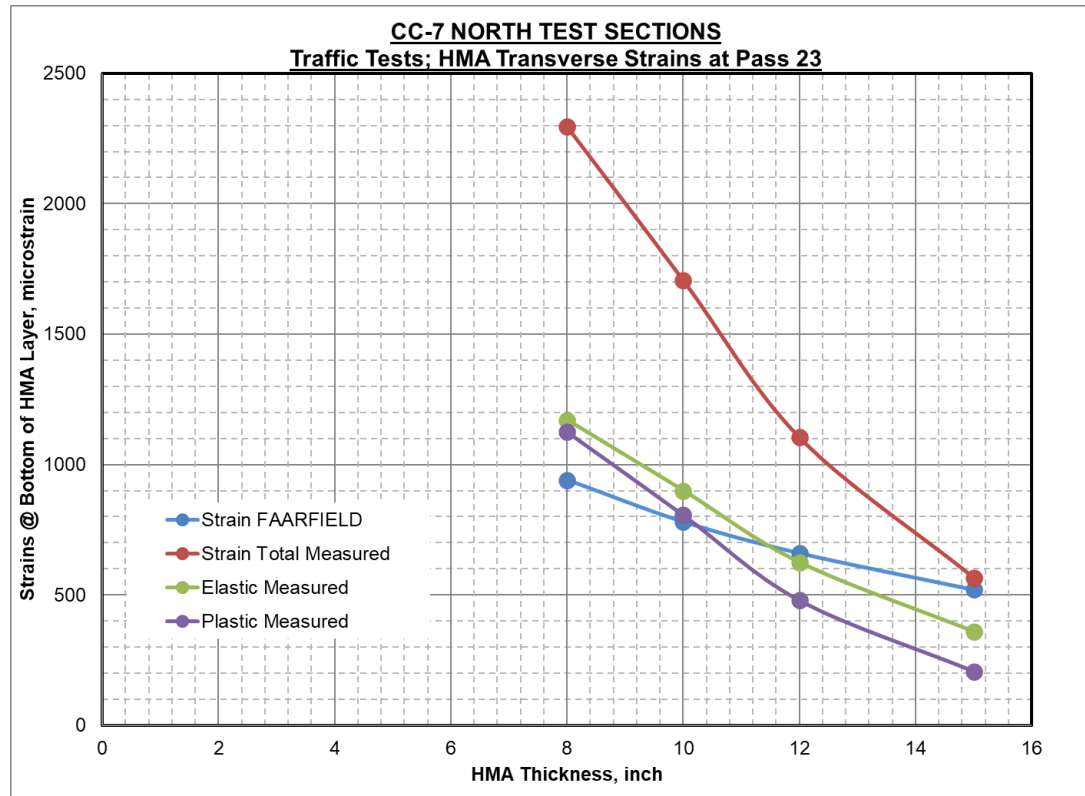

CC-7 Crack Monitoring (LFP-4N)



CC-7 Layer Profiles

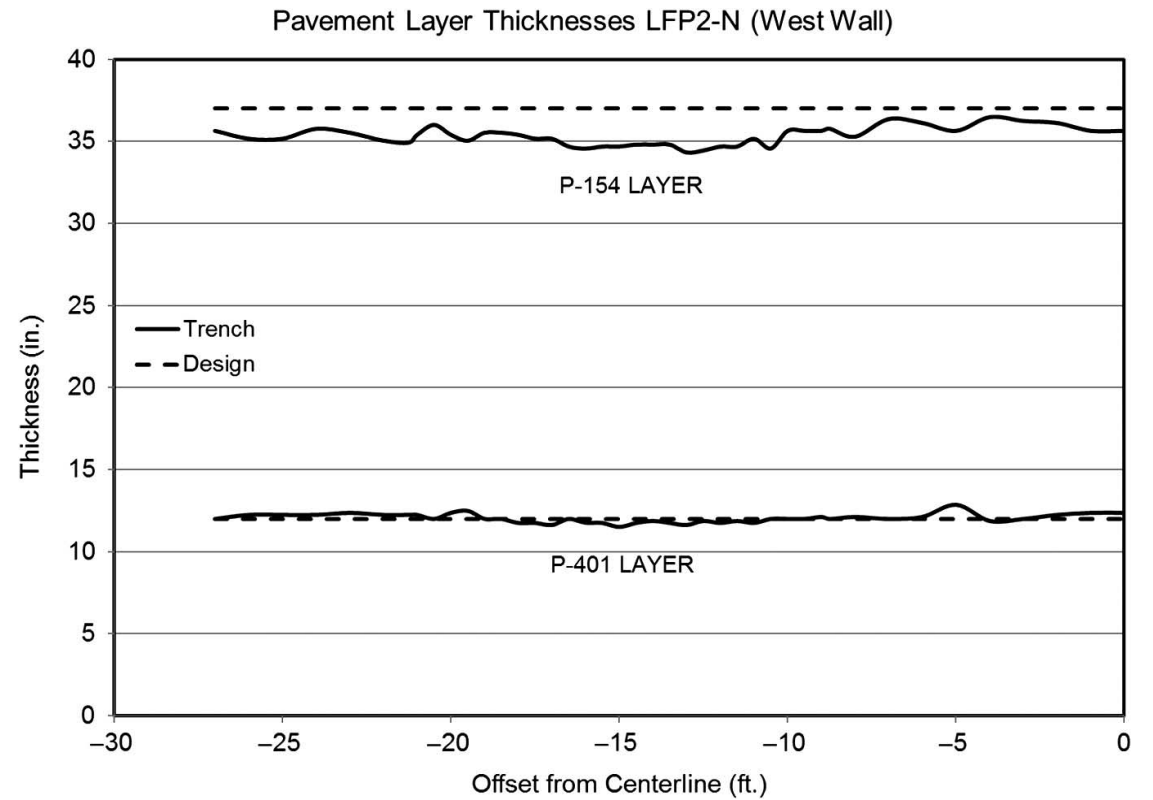
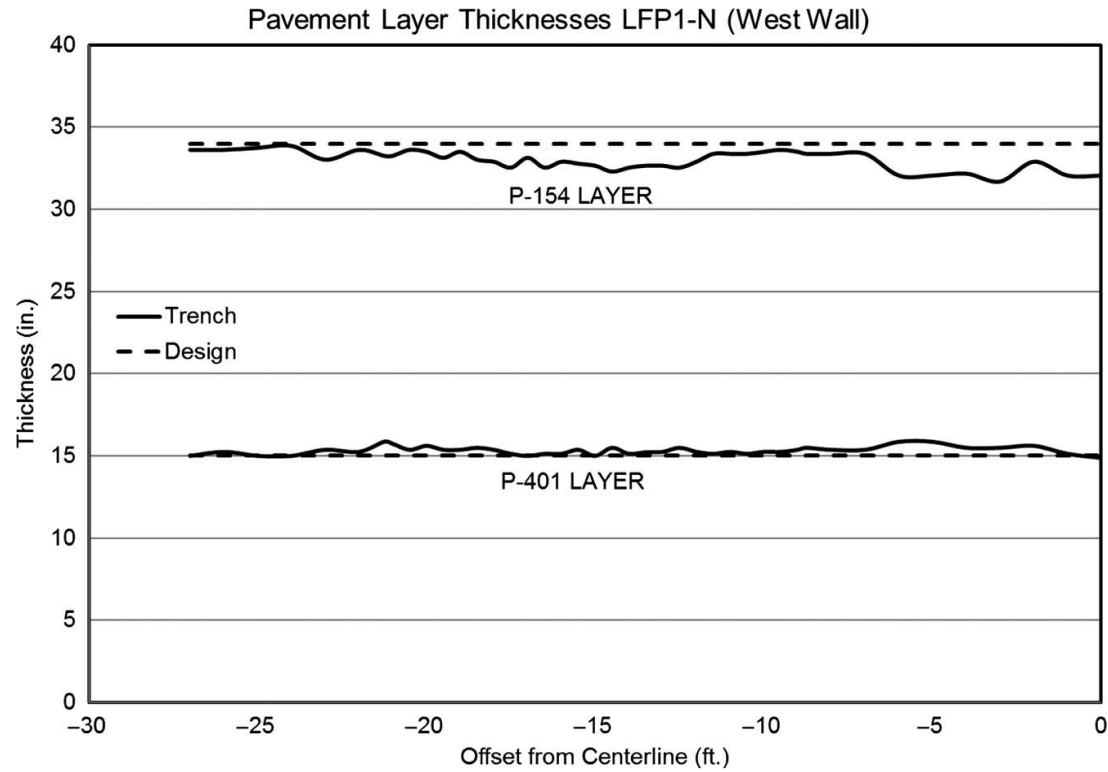

CC-7 Layer Profiles

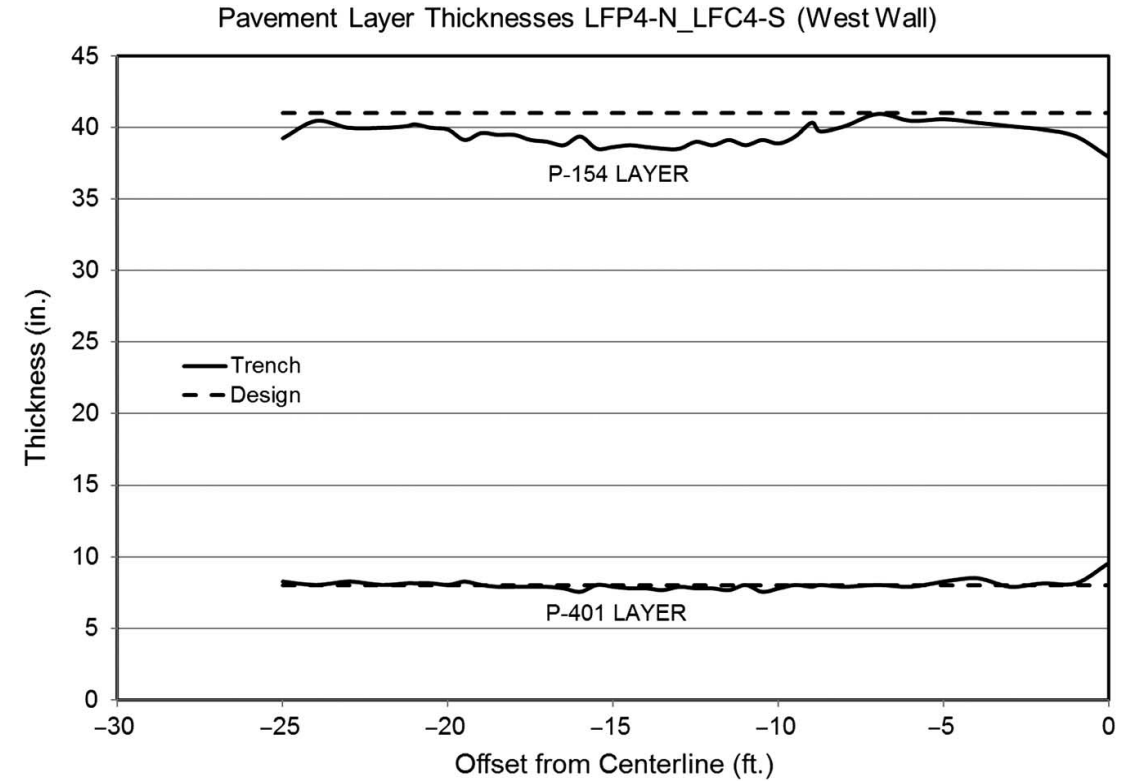
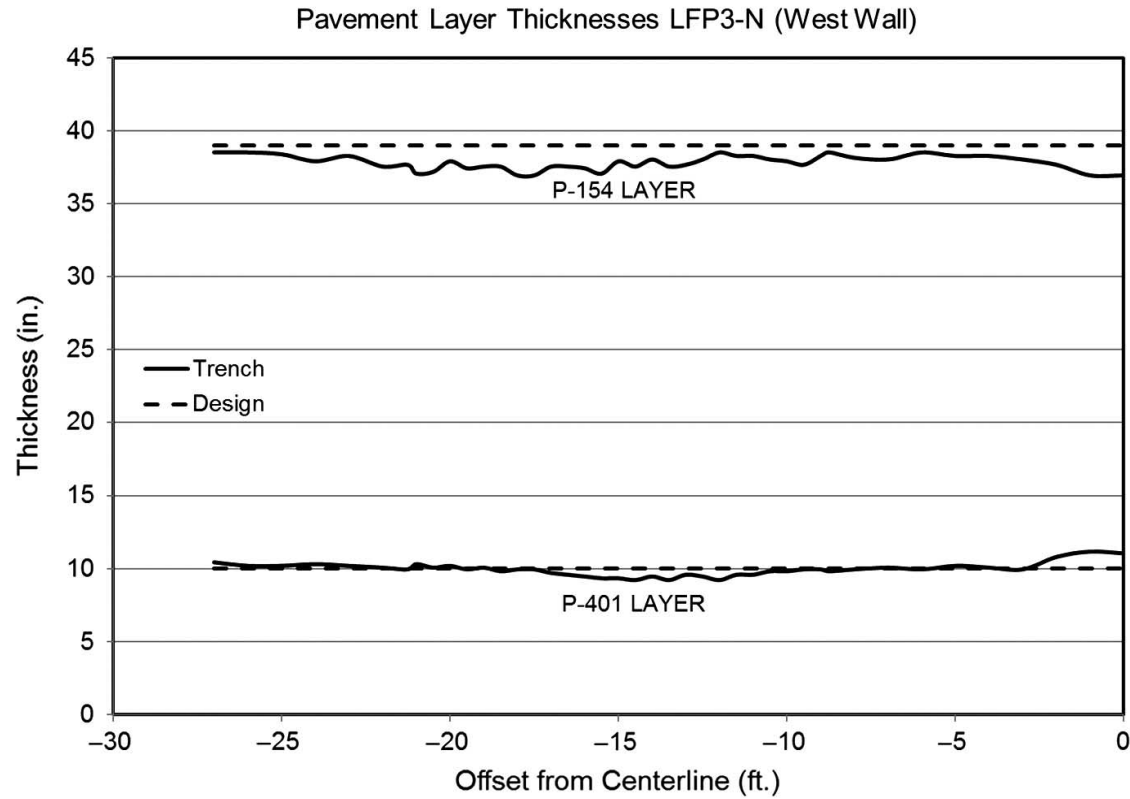

CC-7 Predicted & Observed Fatigue Life

Test Section	HMA Strain (from FAARFIELD)	PV	Pass to Coverage (P/C) Ratio	N _f from FAARFIELD		N _f from Full-Scale APT		Ratio (N _f APT / N _f FAARFIELD)
				Passes	Coverages	Passes	Coverages	
PP-1	0.000524	2.14E-06	0.650	40000	61538	NO CRACKS OBSERVED		
PP-2	0.000657	6.86E-06	0.730	15385	21075			
PP-3	0.000781	1.67E-05	0.790	7407	9376	21450	27152	2.90
PP-4	0.000932	4.14E-05	0.860	3636	4228	11814	13737	3.25

Results – CC7

- Thicker test sections LFP-1N and LFP-2N did not show any evidence of fatigue cracks, whereas LFP-3N and LFP-4N showed severe fatigue cracking.
- All the cracks were found to be top-down cracks.
- By increasing HMA thickness from 10 in (25.4 cm) to 12 in (30.5 cm) fatigue cracking was eliminated during the duration of testing (almost 38,000 passes).
- Observed fatigue life is about three times the predicted fatigue life.

CC-9 Perpetual Pavements

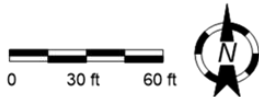
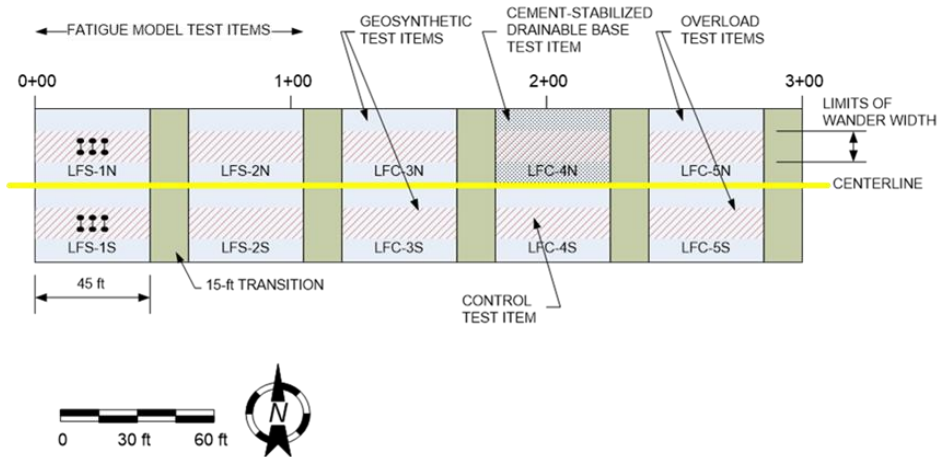

Started: April 5, 2021

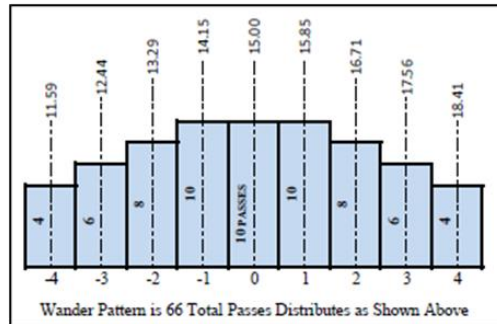

Standard NAPTV Wander Pattern

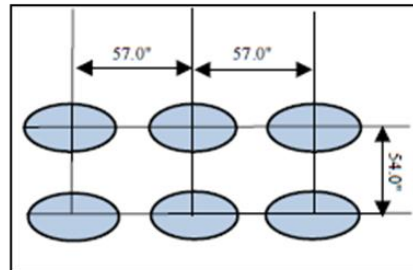

Standard NAPTV Gear Configuration
58,000 lbs/wheel

Pavement Cross Section - North

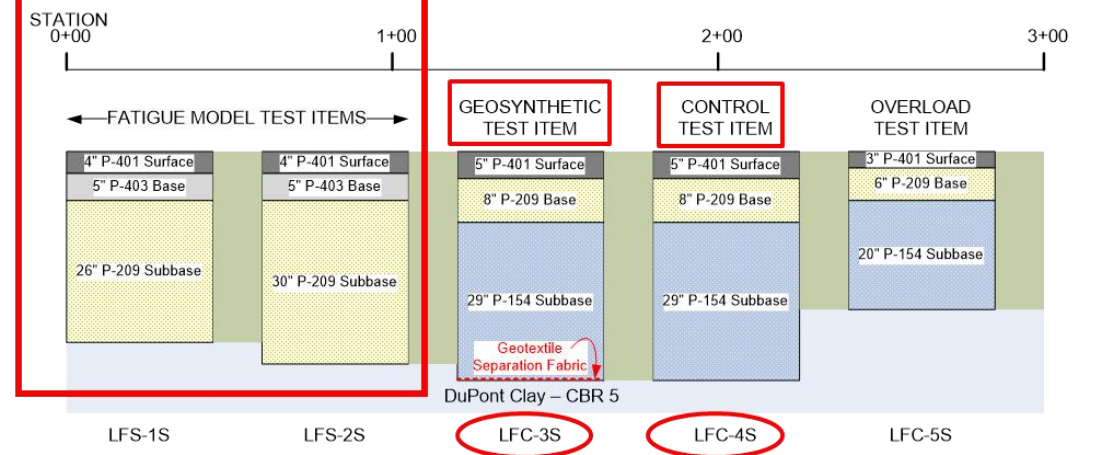
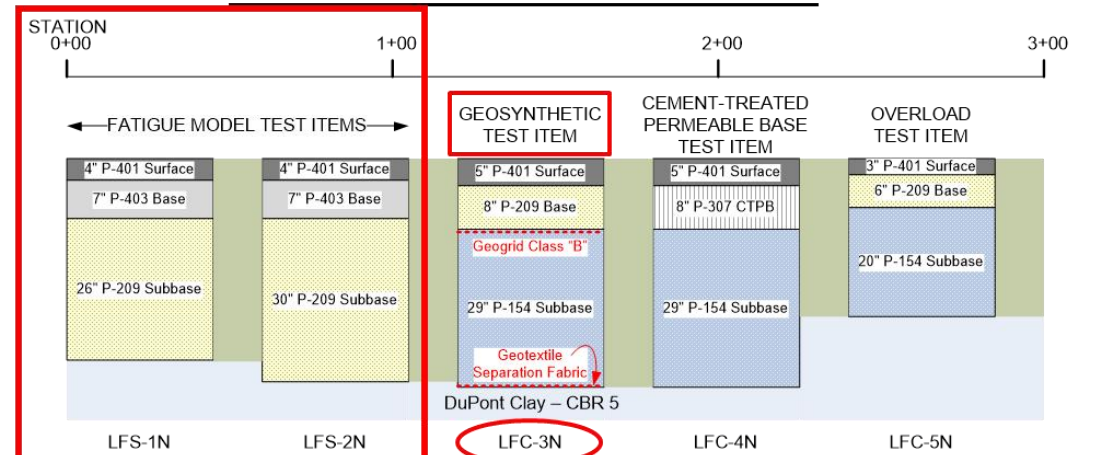

Pavement Cross Section - South

CC-9 HMA Cracking in Fatigue Sections

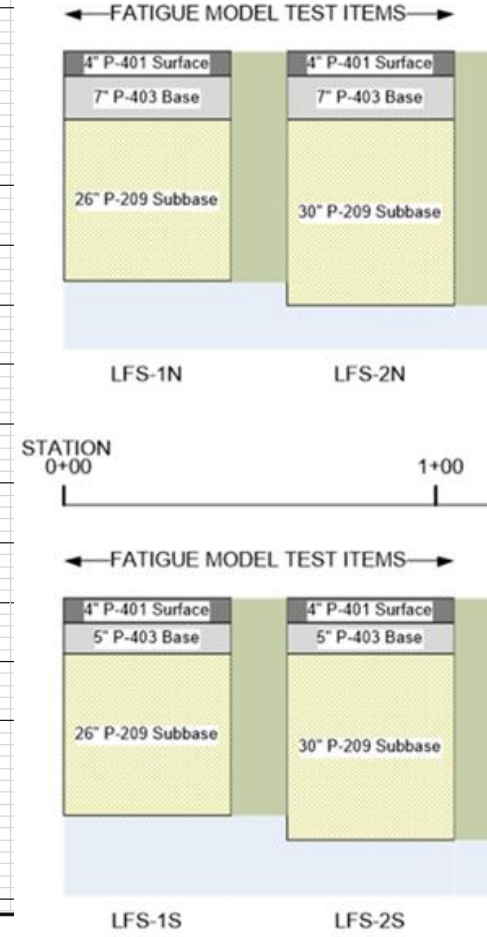
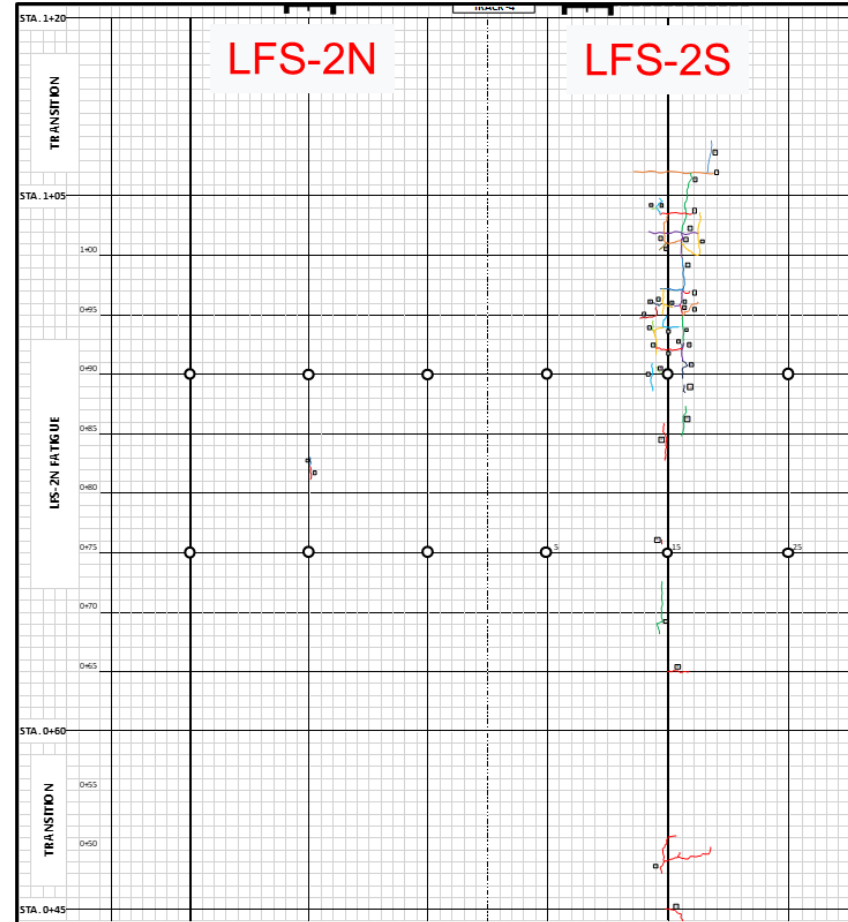
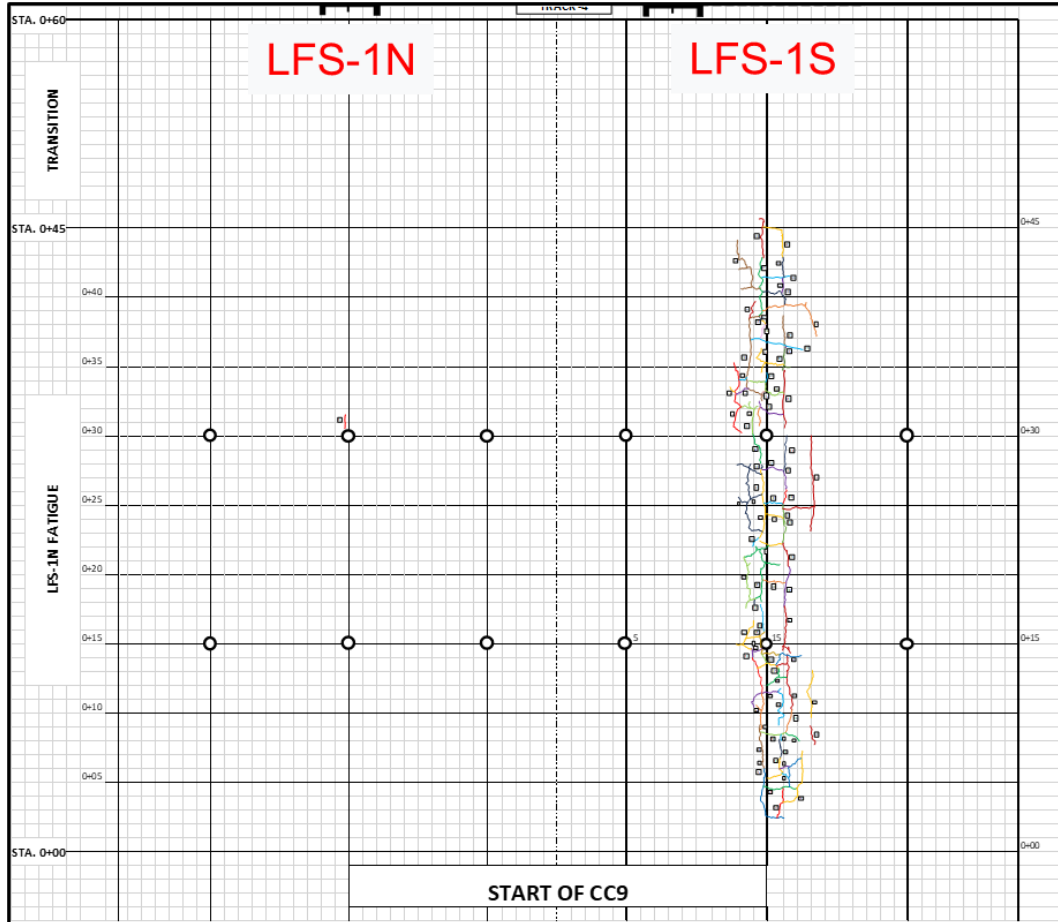

Results – CC9

- Fatigue cracking observed in LFS-1S and LFS-2S (HMA thickness 9 in).
- No signs of fatigue cracking in LFS-1N and LFS-2N (HMA thickness 11 in)
- Measurable surface cracks did not develop until late in the test and, when they did, they affected the south test items (thinner HMA) much more than the north test items.
- No signs of fatigue cracking were observed in LFS-1N or LFS-2N after more than 75,000 passes, even after the load was increased (at 48,313 passes) to 65,000 lb per wheel.
- Test sections LFS-1S and LFS-2S (9 inch thick HMA surface) showed higher rutting than LFS-1N and LFS-2N (11 inch thick HMA surface).

Outline

- Introduction
- Objectives
- HMA Fatigue – FAARFIELD
- Full-Scale Tests at NAPTF – CC7 & CC-9
- Summary



Summary

- All the HMA cracks were found to be top-down cracks.
- Observed HMA fatigue life is about three times the predicted fatigue life.
- Rutting observed in test sections is more sensitive to P401 HMA thickness than P209 thickness.
- Pavement performance in rutting is not as sensitive to subbase thickness as predicted by FAARFIELD design models.
- Sections constructed on P-209 subbase (CC-9) showed slower progression in pavement fatigue cracking compared to sections constructed on P-154 subbase (CC-7).



Navneet Garg, Ph.D., F.ASCE
Program Manager, NAPMRC
(609)485-4483
Navneet.Garg@faa.gov
<http://www.airporttech.tc.faa.gov>

ACKNOWLEDGEMENTS

- ❖ **FAA**
Murphy Flynn
Dr. David Brill
Wilfredo Villafane
Ryan Rutter

- ❖ **ARA**
Dr. Hasan Kazmee
Lia Ricalde
Scott Murrell
Chris Tomlinson

- ❖ **CSRA**
Dr. Qiang Li
Robert Debarth
Bill Doig
Josh Davis
David Traverzo
Sean Combs

- ❖ **Gemini**
Dr. Hao Yin
Dr. Carlos Cary

Today's Presenters



Dr. Buzz Powell
bpowell@asphaltpavement.org

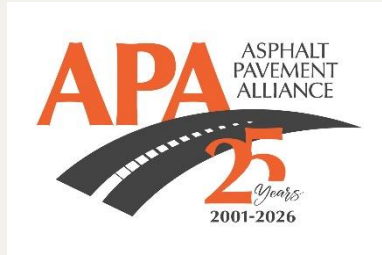

Dr. David Timm
timmdav@auburn.edu



Dr. Bill Vavrik
wvavrik@ara.com



Dr. Navneet Garg
navneet.garg@faa.gov



Upcoming events for you

July 12-15, 2026

65th Annual Workshop on Transportation Law

<https://www.nationalacademies.org/events/1089>

<https://www.nationalacademies.org/trb/events>



NATIONAL
ACADEMIES Sciences
Engineering
Medicine

 TRANSPORTATION RESEARCH BOARD

Subscribe to *TRB Weekly*

If your agency, university, or organization perform transportation research, you and your colleagues need the *TRB Weekly* newsletter in your inboxes!

Each Tuesday, we announce the latest:

- RFPs
- TRB's many industry-focused webinars and events
- 3-5 new TRB reports each week
- Top research across the industry

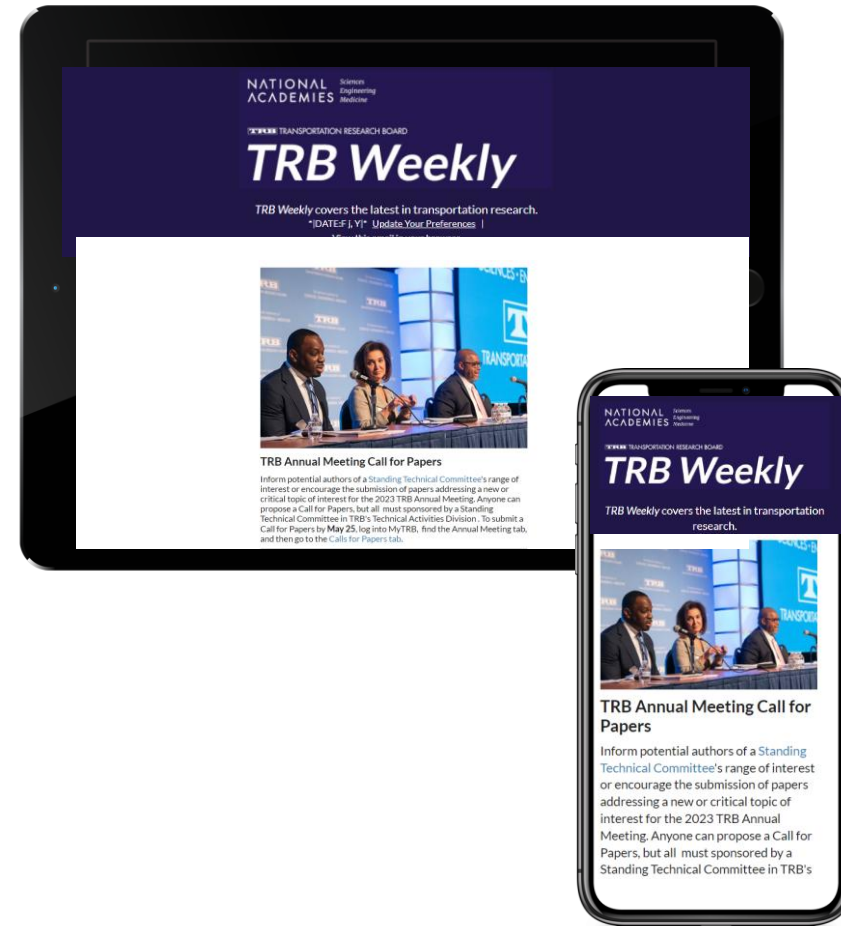

Spread the word and subscribe!

<https://bit.ly/ResubscribeTRBWeekly>

Discover new TRB Webinars weekly

Set your preferred topics to get the latest listed webinars and those coming up soon every Wednesday, curated especially for you!

<https://mailchi.mp/nas.edu/trbwebinars>

And follow #TRBwebinar on social media



Get involved

TRB mobilizes expertise, experience, and knowledge to anticipate and solve complex transportation-related challenges.

TRB's mission is accomplished through the hard work and dedication of **thousands of volunteers**.

<https://www.nationalacademies.org/trb/get-involved>

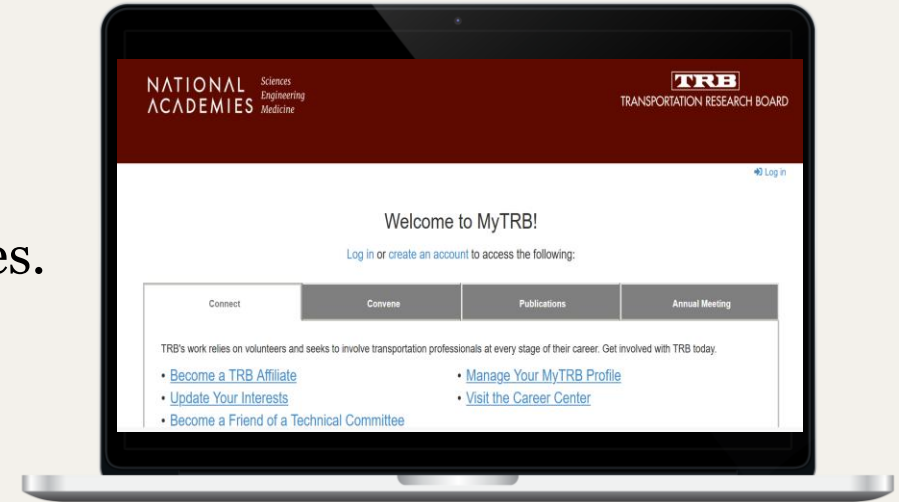

We want to hear from you

- Take our survey
- Tell us how you use TRB Webinars in your work at trbwebinar@nas.edu

