

BMS for Permit Vehicle Routing in Spain

JOAN R. CASAS

ANGEL C. APARICIO

GONZALO RAMOS

Technical University of Catalunya, Barcelona

AGUSTIN SÁNCHEZ-REY

Spanish Ministry of Public Works, Madrid

ABSTRACT

The papers shows the main works developed in Spain for the construction of a Bridge Management System (BMS) to manage the vehicle permits over the bridges of the so-called Strategic Spanish Highway Network, i.e., the most important National highways. This network is owned by the National Government. The different construction times and particularities of the bridge sites results in a large number of different bridge types both in longitudinal (simple supported beam, continuous beam, frame, arch, etc.) and cross-sectional (precast I beams or spread box beams, concrete slabs, box-girder, etc.) configurations. Most of the bridges are quite new and very well documented, but also a huge number of older bridges are present whose data (design drawings, material strength, etc.) is not available. The work is summarized in a Bridge Management System (BMS) installed on a PC computer that in a quick and automatic way performs the structural analysis of the bridges crossed by a defined special permit and compares the results with the maximum allowable actions over the bridge. The final result is the authorization or no authorization. In the paper are discussed the theoretical background used, the design philosophy and the implementation of such a system in Spain. The criteria and methodology may be extrapolated to similar cases in other countries. After some time in operation, the software developed has been shown as a useful tool to assist in the decision-making process for the bridge engineers of the Road Directorate in Spain.

INTRODUCTION

An important effort has been recently developed worldwide by different Transportation Agencies and Departments of Transportation to improve the management decision-making process concerning bridge inspection, maintenance, rehabilitation and replacement activities on a bridge network. This has resulted in the development and updating of different Bridge Management Systems (BMS) dealing with this problem (1-5). However, another classical problem related to bridge management, normally not included in the standard BMS and faced by many Transportation Departments or Highway Agencies, is the decision concerning the passage permission of special trucks with exceptional heavy loads. In fact, in order to be more competitive with other transportation facilities, the road freight companies are increasing pressure on the Bridge

Authorities to permit higher loads on bridges. In some cases this results in the necessity of applying for special truck permits (in geometry and load). In spite of the controlled axle-load to avoid spoiling the pavement, the total truck load and distribution among different axles are of great concern regarding possible damage and service life-time of the bridges in the network. The passage of load permits may create structural problems not only during the crossing operation, but also in the service life of the bridge (cracking in concrete bridges affecting their durability, fatigue in steel bridges, etc.). Therefore, before authorizing the passage of the permit, the Road Agency managing the bridge network should carefully look at the maximum loads acting on the bridges and the problems that may cause according to the actual condition of the bridges derived from periodical inspections. Normally, the process is cumbersome because checking is performed bridge by bridge and requires spending a huge amount of time. Therefore, any system allowing the automatic verification and resolution of this demand is greatly welcomed. To this end, the Road Directorate in Spain decided to develop an automatic tool, in the form of a BMS, to assist bridge engineers on the final decision.

OBJECTIVES AND PROBLEM STATEMENT

The main objective of the BMS is stated in this way: Starting from the data provided by the freight company concerning the special truck (geometry and load distribution among the different axles) and the desired path into the highway network, defined by entry and exit junctions, the authority should decide about the permission and the requirements of the passage (truck centered in the deck, no concomitant traffic, etc.) if any. Although simple in its definition, the objective addresses several "key" problems to be solved before the application to a large highway network:

1. The huge number of bridges to be checked even for a short distance under a load permit.
2. The different construction times and singularities of the bridge sites result in a large number of different bridge types both in longitudinal (simple supported beam, continuous beam, frame, arch, etc.) and cross-sectional (precast I beams or spread box beams, concrete slabs, box-girder, etc.) configurations. Also an important distinction should be made between the so-called "well-documented" and "ill-documented" bridges. The first item includes the most recent bridges for which all documentation is available (as-built drawings, records of quality control during construction, etc.). The second group includes very old bridges and bridges where insufficient information is available to perform a complete structural analysis, or bridges that were designed with a Standard different from the actual. This situation is not particular to Spanish conditions, but quite similar all over Europe, where many old bridges are encountered in the main road networks. As will see later on, this separation becomes very important when facing the methodology of safety checking to be applied.
3. The wide range of load configurations and dimensions of the load permits due to the specific requirements for the items carried.

Regarding the first issue, 3 different solution strategies were identified:

1. To perform a complete structural analysis and evaluation of all bridges involved in the passage in a more or less automatic way. The main advantage is the accuracy and reliability, because each particular bridge is evaluated; the main disadvantage comes from the total number of bridges (about 15,000) present in the network. This will result in a prohibitive amount of money and time to perform the study and also in a rather difficult software development, mainly in the topological definition of the possible itineraries within the complete network.

2. To simulate the passage through a partial (but still representative) and already computerized group of bridges selected from the total network and to obtain conclusions regarding the feasibility of the truck permit passage that could be extrapolated to the rest of the bridges in the overall network. This computerized network was available thanks to the work carried out in previous studies, covering a total of 530 km of the network, where a total number of 733 bridges were completely evaluated and rated. The evaluation includes the definition of a very accurate structural model to analyze the bridge response. The main advantage is the accuracy of the results because real bridges of different types were evaluated. The disadvantage is that the computerized set does not cover all types present in the total network. In fact, not all medium span lengths (up to 60 m) are covered and there is not any long span bridge (more than 60 m) in the set of bridges analyzed. Finally, only few old bridges are present, which are not fully representative of the old bridges present in the network.

3. To create a fictitious network of real bridges, fully representative of all bridge types and spans present in the network, and evaluation of the feasibility of the passage of the permit over the bridges. The second step is the definition of criteria allowing the automatic link of any real bridge in the overall network to one of those “representative bridges.” The link or association is based on the similarity of the response to the external actions. If the permit is allowed to cross the “representative” bridge, then the passage is automatically authorized for all actual “associated” bridges that may be linked to it. The main advantages of this procedure are that all span-lengths and bridge types (well- and ill-documented) may be considered and the time and budget requirements to perform the study are decreased to a minimum. The disadvantage is that the accuracy and reliability of the results may be lower for a real bridge different from the representative one. Therefore, the criteria finally adopted concerning the authorization must be somehow overconservative to account for this inaccuracy.

Strategy number 3 was finally adopted. The first step was to look at all bridges present in the national inventory and to define a set of bridge categories. The definition is performed in such a way that any bridge in the inventory can be assigned to one of the bridge categories. The different categories or types are explained in the sections corresponding to well or ill-documented bridges.

Once the global strategy to deal with all bridges in the network was decided, other requirements were identified to be faced in the BMS:

- The system should contain a general description of the network, with automatic identification of bridges and location in the network.

- Definition of a traffic model representative of the actual traffic on the bridge to superimpose to the passage of the special vehicle (concomitant traffic).
- Definition of the impact coefficients for the concomitant traffic and the vehicle permit.
 - Formulation of a methodology to define the structural capacity (R) of the bridges taking into account the durability and strength requirements during their service life.
 - Definition of a methodology to manage the huge amount of different configurations (axle distances, axle weights, number of axles, . . .) of the actual permits. The final objective is the characterization of typical permit vehicles that will be used in the assessment process.
 - Definition of reliable criteria to decide about permission based on actions over the bridge and structural capacity. This also should include the possible restrictions about normal traffic. The adopted permission criteria should be consistent with the division among well- and ill-documented bridges, and therefore, as will be shown later, two different evaluation criteria were defined. In the case of ill-documented bridges the criteria are based on the Structural Reliability Theory.

NEW AND WELL-DOCUMENTED BRIDGES

This group of bridges includes all the modern bridges designed with a code similar to the actual one, and with all their documentation available (as-built drawings, records of quality control during construction, etc.). From the analysis of the bridge data inventory, the following categories of well-documented bridges were identified:

- a) Bridges supporting the highway with span-lengths more than 10 m (viaducts):
They, in turn, can be divided into:
 - a.1) Bridges with one or more simply supported spans with upper slab on I precast beams
 - a.2) Bridges with one or more simply supported spans with upper slab on precast spread box beams
 - a.3) Continuous bridges with slab on I precast beams
 - a.4) Continuous bridges with slab on precast spread beams
 - a.5) Masonry and concrete arch bridges
 - a.6) Continuous and simply supported box girder bridges
- b) Overcrossings
 - b.1) Continuous prestressed concrete slabs with the following possibilities:
 - b.1.1) Straight in plan and clamped over each pier and abutments
 - b.1.2) Straight in plan and clamped in the abutments and with only one bearing in the piers (torsion free)
 - b.1.3) Curved in plan and clamped over each pier and abutments
 - b.1.4) Curved in plan and clamped in the abutments and torsion free in the piers
 - b.1.5) Fairly skewed ($\alpha < 60^\circ$)
 - b.1.6) Highly skewed ($\alpha > 60^\circ$)

- b.2) Slab on precast prestressed I or spread box beams
 - b.2.1) Straight and simply supported
 - b.2.2) Skewed and simply supported
 - b.2.3) Continuous with spread box beams
 - b.2.4) Cantilever: precast beams supported by cast in situ cantilevers in the piers.
- c) Undercrossings: The normal undercrossing of a typical road (less than 10 m width) under the highway is solved with reinforced concrete frames or box sections with variable depth of earth filling up to 19 m.

All these different bridge types present in the network can be grouped taking into consideration their structural behavior and the different structural models more suitable for their structural analysis in the following categories:

1. Simply supported bridges straight in plan or fairly skewed, with one or more spans and I or spread box precast beams or cast in situ slabs.
2. Continuous decks with constant or variable depth, straight in plan or fairly skewed and clamped to torsion on each pier. The cross-section may be a slab or box-girder.
3. Reinforced concrete frames or box sections.
4. Others: Containing all the bridges not included in the three previous categories.

The strategy to study this group of well-documented bridges was:

1. Characterization of typical permit vehicles.
2. Creation of a fictitious network with representative medium-span modern bridges.
3. Creation of a fictitious network with representative long-span bridges.
4. Obtaining the carrying capacity of all the bridges included in both fictitious networks.
5. Every well-documented bridge of the network must be assigned to a representative bridge of the fictitious network and its carrying capacity must be calculated from the carrying capacity of the representative bridge, including several corrections.

As explained, the first point was to characterize typical permit vehicles. The amount of data was enormous and it was extremely difficult to obtain a pattern of typical permit vehicles. So it was decided to use the collection of permit vehicles from Euro-Code EC-1.Part 3 (6). They range from 600 kN to 3600 kN of total load, with axle load covering 150 kN to 240 kN. The distance between axles is 1.5 m and some of them are formed by two groups of axles separated 12 m. A criteria was derived to assign any actual permit with its particular layout of axles and weights per axle to one of the permits defined in EC-1. The basis is that they produce the same internal forces in the bridge under study.

The second step of the study was to select a group of representative medium-span modern bridges. The used criteria were functional (width of the bridge) and structural (cross-sections and longitudinal typologies and span length). Three different platforms were considered: 7.50 m wide for 1 lane plus shoulders (1 + 4 + 2.5) (corresponding to a bridge on the exit of a highway), 10.50 m wide for 2 lanes plus shoulders (1 + 3.5 + 3.5 + 2.5) and 14.00 m wide for 3 lanes plus shoulders (1 + 3.5 + 3.5 + 3.5 + 2.5). The representative medium-span bridges selected are summarized in Figures 1 to 5.

At the same time a network of fictitious long-span bridges was created. The long-span bridges considered are box girder erected by the balanced cantilever method. A summary of the bridges considered is shown in Figure 6.

Checking criteria for vehicle permit

The criteria used to authorize a permit vehicle on one of these bridges is

$$TE = I_{PV} * IF_{PV} + I_{CT} * IF_{CT}$$

$$R = C_{CON} * IF \text{ (Code Live Load)}$$

$$TE < R$$

where TE is the traffic effect which includes IF_{PV} , internal forces from the permit vehicle multiplied by I_{PV} , the impact coefficient of the permit vehicle, plus IF_{CT} , internal forces from the concomitant traffic multiplied by I_{CT} , the impact coefficient of the concomitant

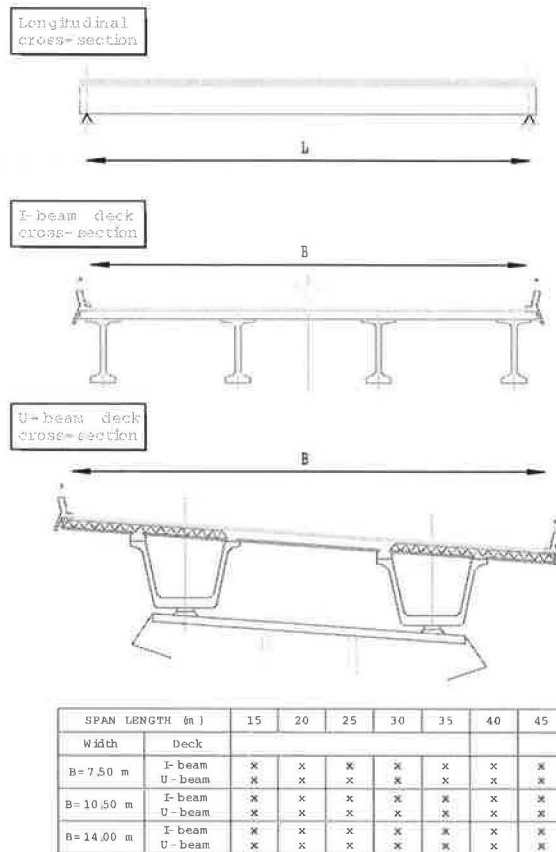

Figure 1: Beam decks.

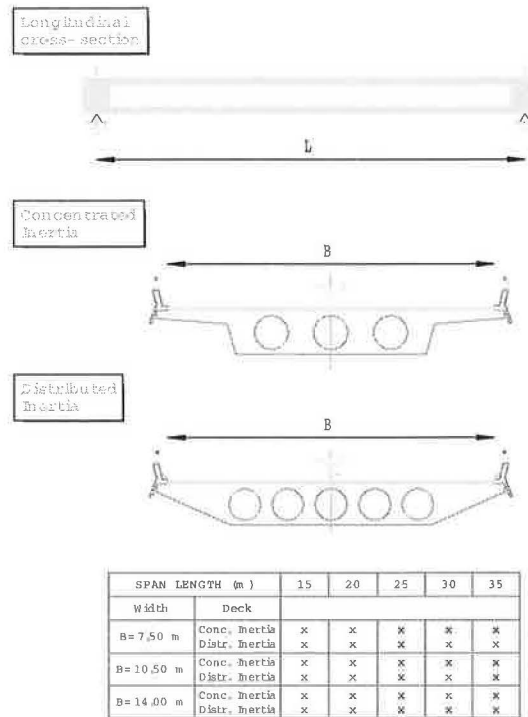

Figure 2: Simply supported slab decks.

traffic; and R is the response which is the product of the conservation coefficient (C_{CON}) times the internal forces due to the live load from the code used for the design (IF).

The permit vehicle is authorized to cross the bridge if the traffic effect is lower than or equal to the response. The concomitant traffic can be neglected if the bridge is going to be closed when the permit vehicle is on the bridge.

This criterion was designed not to avoid the failure of the bridge, whose carrying capacity is clearly over the code live load, but was intended to avoid the possibility that several permit vehicles on the same bridge could accelerate fatigue on reinforced and prestressed steel.

With this criterion, several curves, as shown in Figures 7 and 8, were obtained. The structural model was always based on a grillage analysis. Curves were obtained for the permit vehicles from EC-1 and also for permit vehicles with the same geometry as EC-1, which means the same length. There are also curves considering concomitant traffic or without concomitant traffic, when it is assumed that the permit vehicle crosses through the center of the roadway. After all these curves were obtained, it was studied how to relate a real bridge with these representative bridges. For simply supported bridges the real span lengths and width of the deck are taken into account by interpolation between the existing curves. For continuous bridges the BMS evaluates the maximum and minimum internal forces of the real bridge when the permit vehicle is crossing and compares them with the internal forces of a representative bridge when crossing on an EC-1 permit. With that comparison the system adjusts the most similar representative bridge to the real one and also the EC-1 vehicle to the permit vehicle, always considering

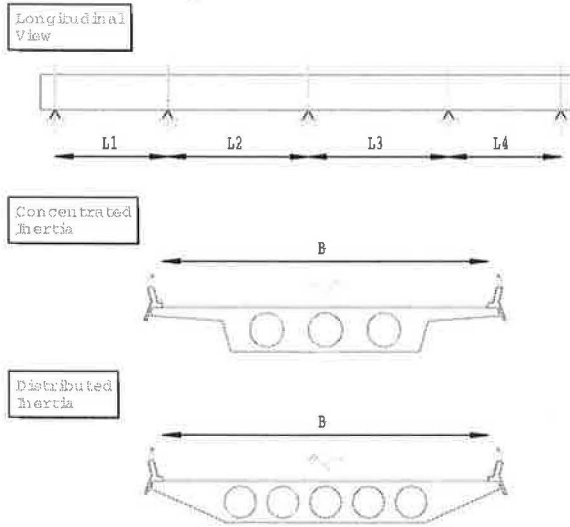

SPAN LENGTH (m)	L1	10	15	18	21	25	30	35
	L2	15	20	25	30	35	40	45
L3	15	20	25	30	35	40	45	
L4	10	15	18	21	25	30	35	
Width	Deck							
B=7.50 m	Conc. Inertia	x	x	x	x	x		
	Distr. Inertia	x	x	x	x	x		
B=10.50 m	Conc. Inertia	x	x	x	x	x	x	x
	Distr. Inertia	x	x	x	x	x	x	x
B=14.00 m	Conc. Inertia	x	x	x	x	x	x	x
	Distr. Inertia	x	x	x	x	x	x	x

Figure 3: Continuous slab decks.

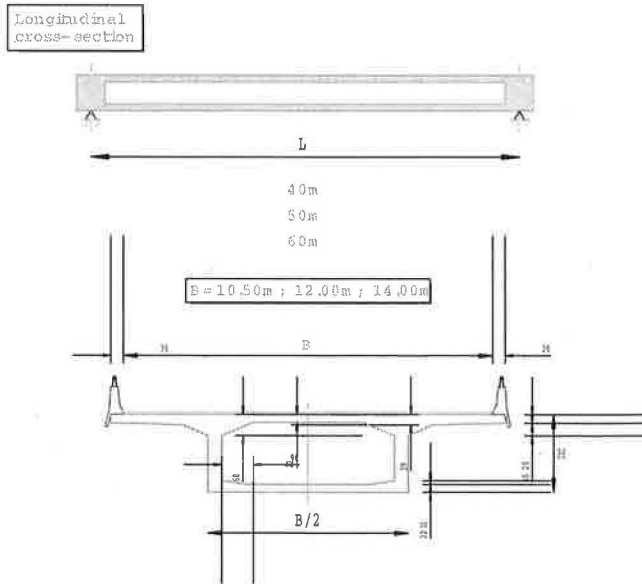

Figure 4: Simply supported box girder decks.

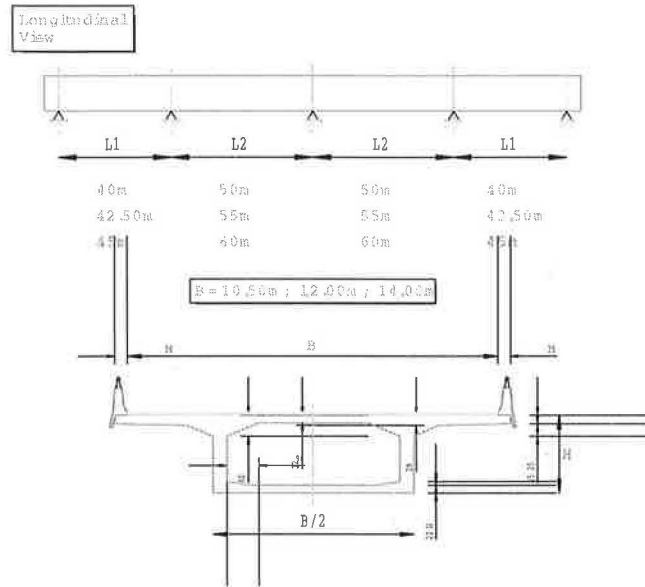

Figure 5: Continuous box-girder decks.

that the internal forces on the representative bridge must be higher than on the real one. The permit vehicle is authorized to cross the bridge if the EC-1 vehicle is under the carrying capacity of the representative bridge obtained from the curve (Figures 7 and 8).

All the assumptions were carefully tested by performing grillage analysis of more than 50 real bridges. The assignment of the real bridges to the representative ones and the corrections to obtain the maximum permit vehicle allowable are made by the computer in an automatic way.

OLD AND ILL-DOCUMENTED BRIDGES

According to the bridge data inventory, the number of old bridges of each type in the National road network is presented in Table 1.

As seen, the total number is important and due to budget and time constraints only few bridges can be completely assessed under the passage of overloaded trucks.

Checking Criteria for Vehicle Permit

For these bridges, the checking criterion is based on a reliability-based technique. Contrary to modern bridges, where the safety format is based on deterministic criteria, in this case the use of a reliability based assessment is mandatory because neither the bridge response nor the allowed maximum load for the bridge is known. In the first case because geometry and material strength are not available. In the second, because the traffic load used in the design of the bridges is not available either. For this reason, a safety format based on the use of partial safety factors is not feasible. The method consists of the assessment of safety in terms of probability of exceeding a specific Limit State.

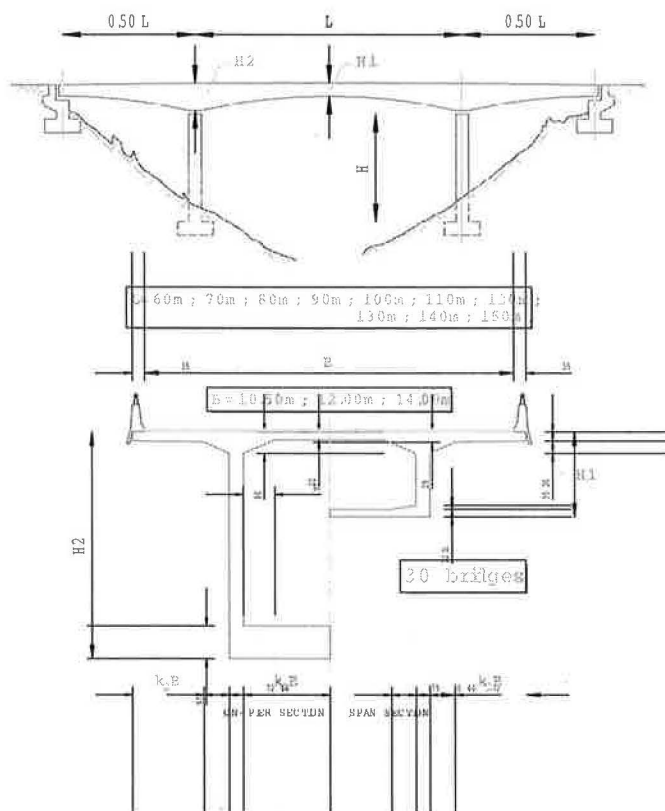

Figure 6: Long-span bridges erected by the balanced cantilever method.

The internal forces caused by the traffic load model in the actual is not representative of the actual bridge resistance. However, old bridges present in the network are actually supporting the existing traffic. For this reason, the adopted checking criterion is to allow the passage of the overweight trucks causing in the bridge a higher (or at least equal) safety level than the safety level because of the real traffic. In terms of the reliability index (β), this is:

$$\beta_{ot} > \beta_{rt}$$

β_{ot} = reliability index due to the passage of the vehicle permit and concomitant traffic

β_{rt} = reliability index due to the actual traffic.

Even if $\beta_{ot} < \beta_{rt}$, the user may decide a positive answer about crossing if $\beta_{ot} > \beta_{adm}$. The value of β_{adm} is adopted by the Highway Agency, representing the minimum value of safety level that the Agency wants to keep in the bridge network. Normally, the adopted value is the one adopted as the target safety level in the calibration of the design code for new structures. The reliability index β is defined as:

$$\beta = -\Phi^{-1}(P_f)$$

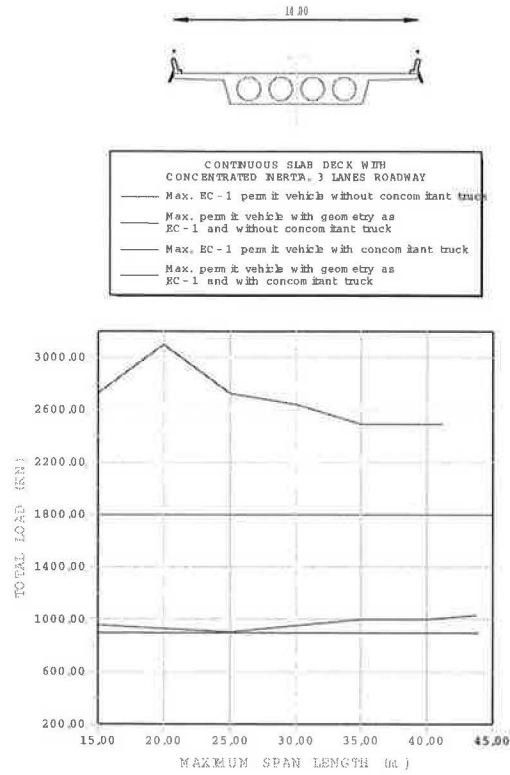

Figure 7: Carrying capacity curves for continuous slab decks.

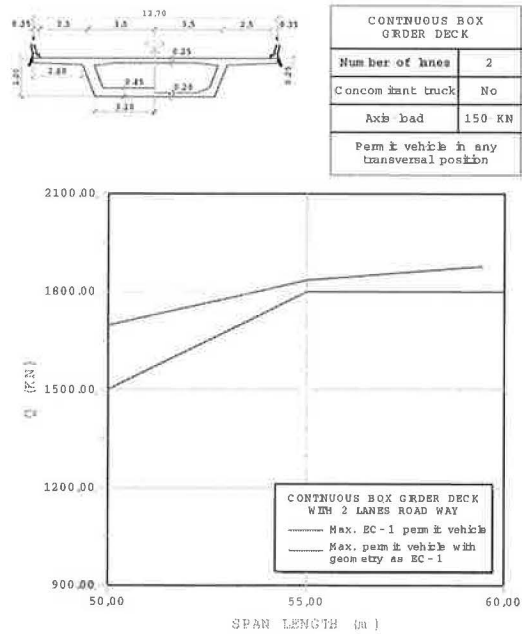

Figure 8: Carrying capacity curves for continuous box-girder decks.

Table 1: Number of Old and Ill-Documented Bridges per Category

Bridge Type	Material	Number
Arch	Masonry and plain concrete	3651
Arch	Brick	408
Arch	Reinforced concrete	34
Simply supported beam	Reinforced concrete	296
Continuous beam	Reinforced concrete	13
Cantilever (Gerber)	Reinforced concrete	2
Portal frame	Reinforced concrete	336
Skewed (beam+slab)	Prestress+ reinfor. Concrete	39
All	Steel	4

where Φ is the cumulative probability function of the standard normal variable and P_f is the probability of failure:

$$P_f = \text{Probability} [R < D + LL]$$

R is the resistance, D is the dead load effect (self-weight plus permanent load) and LL is the effect due to the live loads crossing the bridge. All these effects are random variables. The statistics of resistance R and dead load effect D must be evaluated according to an experimental survey for several selected representative bridges. Therefore, for these bridges, the first step in the evaluation process is to perform an experimental survey to collect all data (geometrical and mechanical) necessary to define the random variables R and D. For those bridges where some partial information (some drawings and material properties) is available, and only the live-load used in the design is unknown, the statistics of R and D are evaluated according to the "a priori" distributions available from other inspection studies, up-dated according to the specific values for each bridge obtained in the experimental survey, and using a Bayesian up-dating technique. The statistics of the maximum effect due to traffic during the remaining service life of the bridges are evaluated via a traffic simulation program (7). To obtain β_{ot} , the mean values of the random variables related to the overloaded truck (axle load, axle spacing, etc.) are derived from the characteristics of the vehicle permits in Euro-Code EC-1. The standard deviation was obtained from surveying of these variables for the most usual vehicle permits authorized in the Spanish network.

Selection of Representative Bridges

Ten bridges have been finally selected as the most representative for the study of bearing capacity using reliability-based techniques. The selection was made taking into consideration the longitudinal profile, material and structural significance (within a group the selected bridge was that with the maximum span length and traffic). In the 10 selected bridges, representative of all non-documented bridges present in the network, and to apply the above mentioned evaluation format, the following works were carried out:

1. Preparation of a tender document concerning the visual, geometric and mechanical data to be obtained from “in situ” and laboratory testing.
2. Execution of the works. Definition of geometric variability in the different elements and extraction of cores and samples of the different materials (brick, masonry, concrete, steel).
3. Testing of samples in the laboratory to obtain data on the actual material strengths.
4. From the “in situ” inspection and the laboratory results, a report was prepared that will be the basis to derive (or up-date) the statistical definition of the basic variables involved in the resistance (R), as well as the permanent loads (D) during the reliability-based assessment.
5. Construction of a structural model and calculation of the influence lines of the desired internal forces in the critical cross-sections of the bridge.
6. Simulation of actual traffic over the bridge and calculation of the maximum traffic effects for a remaining service life of 100 years. This allows the statistical definition of the variable LL. A computer model for the simulation of traffic flow was used (7). The input data for the model related to vehicle’s speed, distance between vehicles, truck weights, etc. . . was derived from real traffic data collected by the Spanish Road Directorate (CEDEX) in locations close to the bridge sites. In order to be representative of the heaviest traffic conditions encountered in the weighing stations within the network, in all bridges the Average Daily Truck Traffic used in the analysis was fixed at 6,000 trucks for a two-lane one-direction roadway. In this way, the minimum reliability index in normal operation conditions is obtained.
7. Calculation of β_r .
8. Simulation of the passage of special permits in EC-1 and calculation of LL_{permit} .
9. Calculation of β_{ot} and definition of allowed EC-1 permits for the bridge.

As an example, in Figure 9 are drawn the reliability indexes obtained in the Magarola Bridge, representative of the bridges built of masonry arches. Q is the total weight of the EC-1 permit. The two possibilities: vehicle permit without traffic (cent.) and vehicle permit on the right lane with concomitant traffic (ec.) are evaluated. As seen, for some EC-1 permits, β is lower than for normal traffic. However, because β is greater than 10 in all cases, the conclusion is to authorize all EC-1 vehicles, because the required safety level is assured, being larger than for a new bridge. Table 2 shows the summary of the results obtained in the 10 selected bridges.

Treatment of Real Bridges

Each selected bridge represents a group of bridges and after the process explained above has a bearing capacity (possibility of overweight trucks) presented in terms of the maximum permit in EC-1 that is allowed to cross the bridge. For the authorization criteria of a real vehicle permit crossing any other bridge, the following steps are necessary:

1. To transform the real permit into an equivalent EC-1 permit ($EC-1_{eq}$). The process is the same as described for the well-documented bridges.

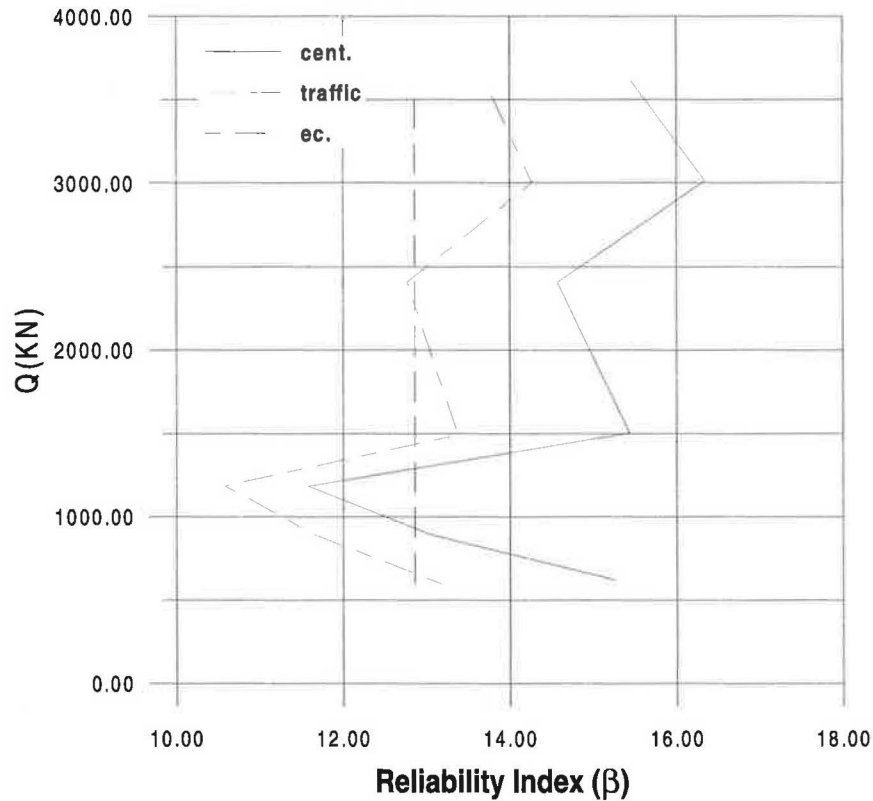

Figure 9: Summary of results in Magarola Bridge (brick arches).

Table 2: Reliability Indices for Actual Traffic and Maximum Allowable EC- Permit.

Bridge	Representative of Group	β_{rt}	Maximum EC-1 permit
Magarola	Brick arch	12.9	3600 kN
San Rafael	Plain concrete arch	17.6	3600 kN
Nalón	Cantilever+ precast beams	6.6 (bending)	2400/200/200 (ec.)
		3.15 (shear)	3600/200/200 (cent.)
Jerte	Masonry arch	5.9	3600/200/200
Miranda de Ebro	Reinforced concrete arch	3.33 (deck)	1800/150 (ec.)
		3.84 (arch)	3600/130/130 (cent.)
Manzanares	Reinf. Concrete continuous	3.16	600/150 (ec.)
			1800/150 (cent.)
Arriondas	Steel arch	6.61 (deck)	1800 kN (ec.)
		6.43 (arch)	2400 kN (cent.)
Campos	Reinf. Concrete simply-supported	2.54 (bending)	900/150 (ec.)
		3.52 (shear)	1800/150 (cent.)
Zaragoza	Reinf. Concrete portal frame	6.51 (bending)	1800/150 (ec.)
		3.88 (shear)	3600/130/130 (cent.)
Haro	Skewed precast beams	4.20 (bending)	3600/200/200
		3.34 (shear)	

ec = eccentric crossing of permit with concomitant traffic
cent = centered crossing without traffic

2. To assign the bridge under consideration to one of the groups and, as an immediate consequence, to obtain the maximum EC-1 permit allowed for the bridge ($EC-1_{allw}$).
3. If ($EC-1_{eq}$) is lower than ($EC-1_{allw}$), then the passage is allowed

CONCLUSIONS

1. The methodology presented solves the problem of authorization of vehicle permits in the National Highway network in an automatic, quick, reliable and economic way, using the data provided by the Bridge Inventory.
2. Using the set of permit vehicles of the Euro-Code as standard values for the capacity assessment produces homogeneous additional information, in the sense that bridges in the network may be ranked according to the maximum allowable permit.
3. The results of the study, regarding the relationship of the capacity of different bridges to a set of standard permits, can be used by the freight companies as guideline when looking at the optimum distribution of axle weights.
4. The basis of the study here presented will be used in the module that will check the bearing capacity of bridges in the general BMS that is now under development by the Road Directorate.
5. The study allowed the assessment of the actual bearing capacity of old bridges under the traffic loads now present in the network, thus giving a value of the safety level of these bridges. As seen, the level of safety of old bridges is highly dependent on the type and material. Therefore, this result will be used in the future to prioritize funds allocated for strengthening and replacing. As shown, arch bridges, although being the oldest in the network, still have an important safety level.

REFERENCES

1. O'Connor, D., and Drumm, R. Bridge Management Systems. In *Transportation Research News 173*, TRB, National Research Council, Washington, D.C., 1994, pp. 17–21.
2. Brito, J., and Branco, F.A. "Bridge Management Policy using Cost Analysis." *Proceedings of the Institution of Civil Engineers, Structures and Buildings*, Vol. 104, 1994, pp. 431–439.
3. ASCE. Bridge Management: A Panel Discussion. Proceedings of the XIII Structures Congress of ASCE, Boston 1995, pp. 666–683.
4. Frangopol, D.M., and Estes, A.C. "Lifetime Bridge Maintenance Strategies Based on System Reliability." *Structural Engineering International*, Vol. 7, No. 3, August 1997, pp. 193–198.
5. Different authors. Series of papers on BMS. *Structural Engineering International*, Vol. 8, Nos. 3 and 4, August–November 1998.
6. CEN. *ENV 1991–3: Basis of design and actions on structures. Part 3: Traffic loads on bridges*. Brussels, 1995.
7. Crespo, C., and Casas, J.R. "A comprehensive traffic load model for bridge safety checking." *Structural Safety*, Vol. 19, No. 4, 1997, pp. 339–359.