

Evaluation of AGWA-II Thermal Conductivity Sensors for Soil Suction Measurement

D. K. H. WONG, D. G. FREDLUND, E. IMRE, AND G. PUTZ

Several tests (both laboratory and full-scale) were conducted to assess the potential of AGWA-II thermal conductivity sensors to measure soil suction in geotechnical engineering applications. The tests conducted in the laboratory included examining the response of the sensors submerged in water, calibrating the sensors in a pressure plate, and measuring soil suction in undisturbed soil specimens. Initial tests conducted on the sensors indicated some inaccuracies associated with the linear calibration curves suggested by the manufacturer. The calibration results showed that the calibration curves for the sensors were bilinear with a breaking point at about 175 kPa. Reasonable agreement was found between the calibration curves obtained in this study and those provided by the manufacturer for matric suction ranging from 0 to 175 kPa. However, large deviations in the calibration curves were observed at suction above 175 kPa. With the calibrated sensors, a testing program was carried out by measuring soil suction in undisturbed soil specimens. Upon the completion of the laboratory tests, the sensors were installed in the subgrade soils of an indoor test track for long-term monitoring. The sensor outputs were found to be relatively consistent and stable with time.

The importance of reliable devices for measuring soil suction has long been recognized. The need for quantitative information on soil suction has led to the development of a number of suction-measuring devices. These include conventional tensiometers, thermocouple psychrometers, null pressure plates, and thermal conductivity sensors. The limitations of these devices have been reported by a number of investigators (1,2). Of these devices, the thermal conductivity sensor appears to be quite promising. It is unaffected by salts in the soil and can be used to measure suction over a fairly wide range (3,4).

In 1986 the University of Saskatchewan undertook a study, funded by the Saskatchewan Highways and Transportation Department, to evaluate the potential of thermal conductivity sensors to measure soil suction in the subgrade of pavements in Saskatchewan.

Thermal conductivity sensors have been evaluated by a number of investigators. Lee and Fredlund (5) used a commercial conductivity sensor, the MCS 6000 (manufactured by Moisture Control System Incorporated, of Finlay, Ohio) to measure matric suction in both plastic and nonplastic soil

specimens. Curtis and Johnston (6) used this type of sensor in a major hydrological process evaluation. By 1984 the MCS 6000 sensor was no longer available commercially. A similar thermal conductivity sensor, the AGWA-II (manufactured by Agwatronics Incorporated, of Merced, California), was used in this study.

To accomplish the study objectives, a series of laboratory tests was conducted in three stages before a full-scale test was performed. The tests conducted in the laboratory included examining the response of the sensors submerged in water, calibrating the sensors in a pressure plate apparatus, and measuring soil suction on undisturbed soil specimens.

Initial tests conducted on the sensors indicated inaccuracies associated with the sensor calibration curves provided by the manufacturer. Each AGWA-II sensor is supplied with a linear calibration consisting of an intercept value and a slope. After difficulties were experienced in obtaining reasonable and consistent results, calibration tests were performed in an attempt to better define the relationship between the sensor output and matric suction. The recalibrated sensors were then used to measure soil suction in undisturbed specimens.

Upon completion of the laboratory tests, the AGWA-II sensors were installed in the subgrade soils of an indoor test track for long-term monitoring. The stability and reproducibility of the sensor output were evaluated throughout the period.

EQUIPMENT

The equipment used in this study included the AGWA-II thermal conductivity sensors, a hand-held Agwameter, and a data-acquisition system. A modified pressure plate extractor, along with a temperature control box, was also used during the calibration study.

AGWA-II Thermal Conductivity Sensor

The AGWA-II thermal conductivity sensor is a commercial development of the unit described by Phene et al. (7-9). The sensor consists of a miniature heater and a temperature sensor, which is embedded in a cylindrical porous ceramic block that forms the sensor tip. The lead wires for the miniature heater and the temperature sensor are sealed to the cylindrical block with a thermally conductive epoxy. Figure 1 shows a cross section of the thermal conductivity sensor.

D. K. H. Wong, D. G. Fredlund, and G. Putz, Department of Civil Engineering, University of Saskatchewan, Saskatoon, Saskatchewan S7N 0W0, Canada. E. Imre, Technical University of Budapest, H-1521, Budapest, Műegyetem-Rkp 3, Hungary.

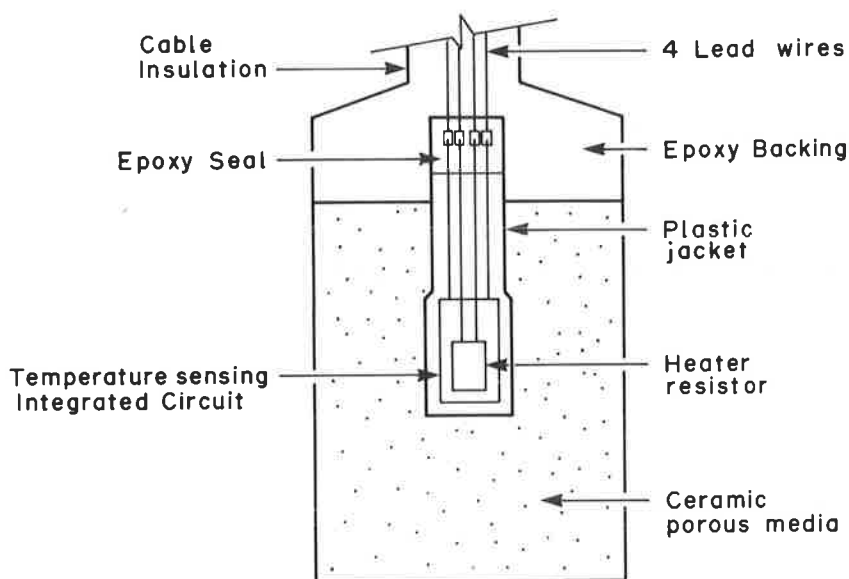

FIGURE 1 Thermal conductivity sensor (cross section).

The sensors indirectly measure the matric suction in a soil by measuring the heat-dissipation capacity of the water content in the sensor tip, which is a function of matric suction in the soil. Heat-dissipation capacity is, in turn, a function of water content; therefore, it may be related to soil matric suction. The heat dissipation by the water phase is measured by supplying a controlled amount of heat at the center of the porous medium and measuring the temperature rise at the same point after a fixed period of time. The change in temperature is a function of water content, and therefore it can be corrected to matric suction by means of a calibration procedure.

The water content of the sensor tip is sensitive to matric suction changes because the porous medium of the tip has a wide distribution of pore sizes. As a result, the sensor tip should commence desaturating or saturating in response to small changes in matric suction. The passage of air to the sensor tip is an important factor that can influence sensitivity at low matric suction values (i.e., below approximately one atmosphere). However, the sensors are generally installed in the bottom of holes augered into the soil, and ambient air pressure is close to the top of the sensor or may be indirectly in contact by passage along the interface between the sensor cable and the soil.

Hand-Held Agwameter

The hand-held Agwameter, which is also commercially available from Agwatronics, is a portable data display used to monitor AGWA-II sensors. The hand-held meter supplies a constant current source to the heater element within the sensor and measures the temperature change at the center of the ceramic block after the heating cycle. The measured temperature change, which is expressed in terms of a change in voltage, is shown on the liquid crystal display after the read cycle. The hand-held meter was used to monitor AGWA-II sensors for both the laboratory tests and the full-scale testing portion of the study.

Data-Acquisition System

The data-acquisition system comprises a Hewlett-Packard 3421A data-acquisition and control unit, a Hewlett-Packard 10-channel multiplexer assembly, board, a sensor interface and power supply (SIPS) unit, and a desktop microcomputer. Figure 2 shows the major components of the data-acquisition system.

The desktop microcomputer acts as a central controller for the entire data-acquisition system by dispatching commands to the data-acquisition and control unit. Commands, such as opening and closing the sensor internal heater circuits and measuring the temperature sensor voltages, are activated through the channel multiplexer that is housed inside the data-acquisition and control unit. The SIPS board provides power for the sensor heater circuits and conditions the temperature sensor voltage signals before input to the data-acquisition system.

The data-acquisition and control system with a 10-channel multiplexer can measure up to eight sensors in succession (two channels are used to control the heater circuits). The system can be enhanced to measure up to 16 sensors by installing an additional multiplexer. The data-acquisition system with a 10-channel multiplexer was used to monitor the AGWA-II sensors for the laboratory tests.

LABORATORY TESTS

The tests conducted in the laboratory are described in the following sections. The sensors were monitored by both the hand-held meter and the data-acquisition system.

Submergence of Sensors in Water

The following test was performed to verify the integrity of the sensors under saturated conditions. A total of 15 sensors were submerged in a small glass container of water at room

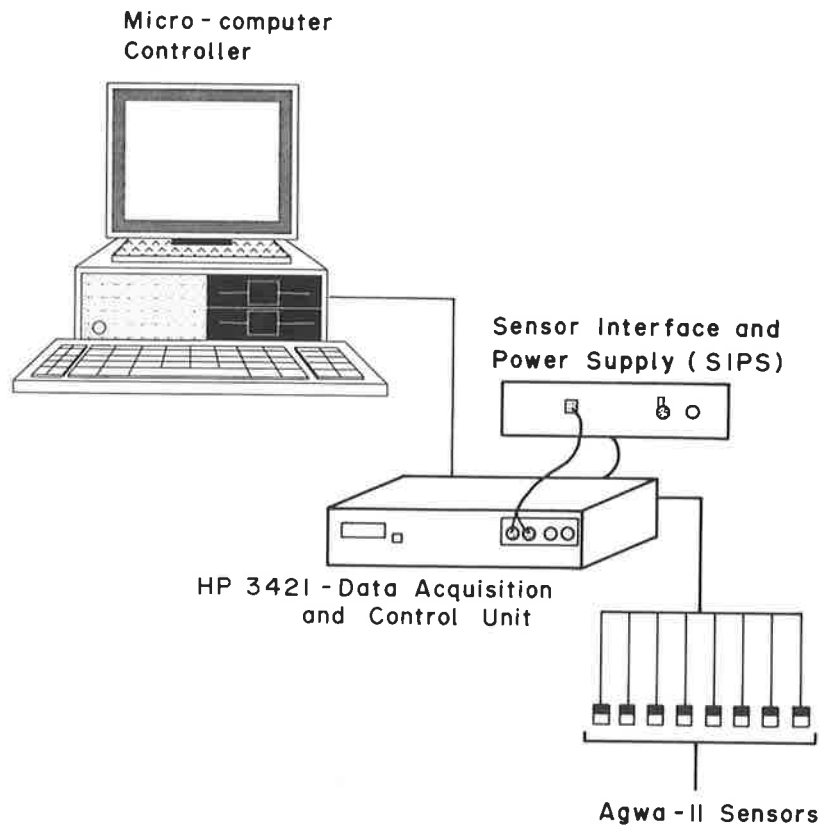

FIGURE 2 Major components of the data-acquisition system.

temperature for about a week. The sensors were then left to dry at room temperature and room relative humidity conditions. After they were air-dried for 1 day, the sensors were again submerged in water at room temperature until the test was completed. The temperature in the laboratory varied from 20°C to 24°C, and the sensors were generally monitored once or twice a day with the hand-held meter. The data-acquisition system was used occasionally to provide a continuous monitoring record.

The objective of the submergence test was to verify that the sensors responded to wetting and drying and to provide an indication of their output range. Air trapped in the sensor tip when the sensor is fully submerged may influence the saturation readings. However, it is difficult to ensure complete saturation, and for the purpose of response assessment, it was believed that water submergence was a reasonable simulation of in situ conditions.

Effect of Wetting and Drying

Typical behavior of the sensors under a drying and wetting cycle is shown in Figures 3 and 4. In general, the results show that the sensors that were submerged in water at room temperature for about a week indicated a matric suction ranging from ± 10 to ± 40 kPa according to the calibration equations provided by the manufacturer. After the sensors were air-dried at room temperature for one day, the measured matric suctions typically ranged from 175 to 475 kPa. Measurements converged back to between ± 10 to ± 40 kPa after the sensors were resubmerged in water.

Figures 3 and 4 demonstrate that the sensors were responsive to different applied suction conditions. Low suction values were obtained when sensors were subjected to a saturated condition, and high suction values resulted when sensors were allowed to dry. However, the sensors did not read zero suction according to the calibration equations provided by the manufacturer even though they were submerged in water for approximately 80 days. In some cases, they even read negative matric suction (i.e., a positive pressure). The fact that the sensors did not read zero suction at simulated saturation and zero suction conditions may be the result of air entrapment or minor inaccuracies associated with the calibration tests.

A summary of the sensor outputs read with the hand-held meter in both the water-submerged and air-dried conditions is presented in Table 1. The difference in the sensor outputs under these two conditions gives an indication of the measurable output range, which varied from 69 to 233 mV among the sensors. The implication is that sensors with the larger output range had a higher sensitivity to matric suction changes than those with a narrower output range.

Effect of Prolonged Submergence

Of the 15 sensors that were submerged in water for monitoring, two failed during the test. The typical response of a failed sensor is shown in Figure 5. The sensor initially responded to the drying and wetting cycle and reached complete equilibrium about 30 days after it was resubmerged in water. However, failure occurred soon after equilibrium was achieved. The sensor showed a dramatic response change, indicating an

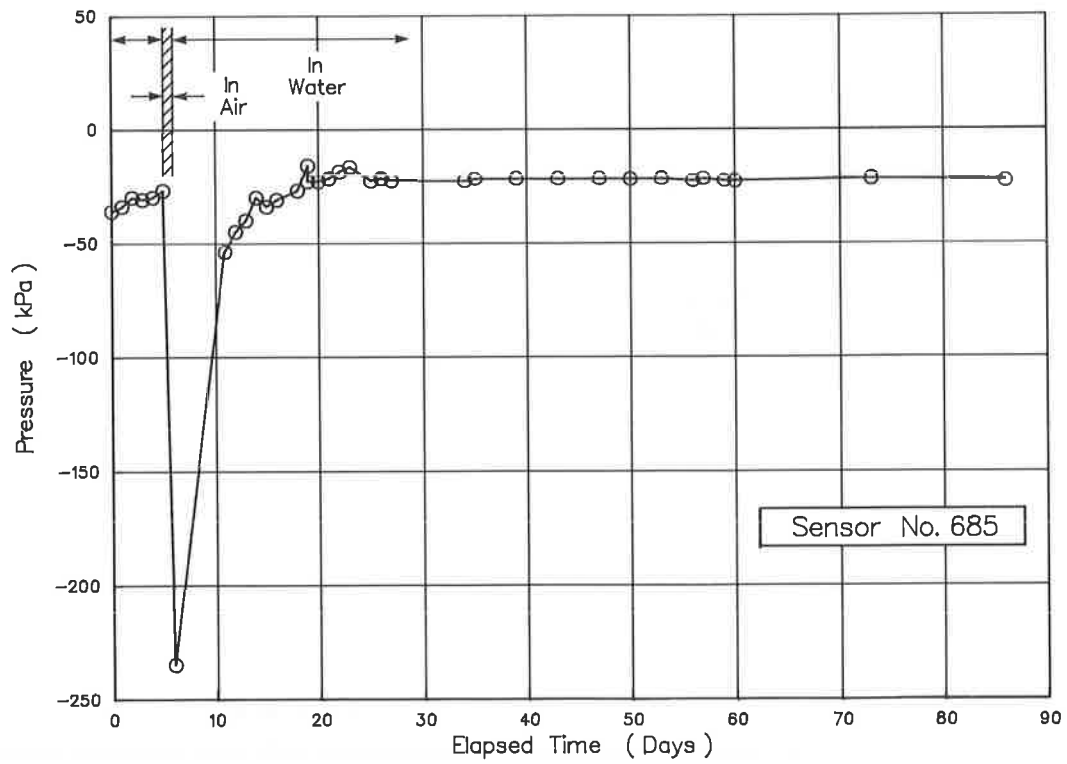

FIGURE 3 Response of Sensor 685 under wetting and drying cycle.

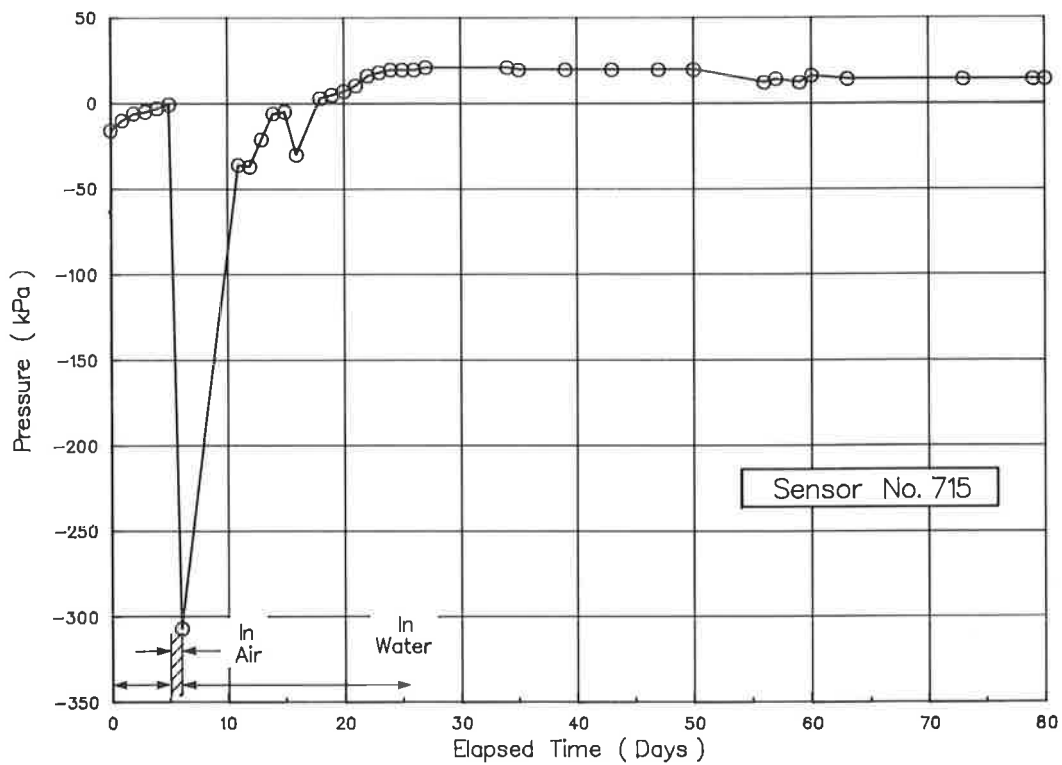

FIGURE 4 Response of Sensor 715 under wetting and drying cycle.

TABLE 1 SUMMARY OF THE SENSOR OUTPUTS READ WITH HAND-HELD AGWAMETER IN WATER-SUBMERGED AND AIR-DRIED CONDITIONS

Sensor No.	Reading at Water-Submerged Condition (ΔmV)	Reading at Air-Dried Condition (ΔmV)	Output Range (mV)
480	143	212	69
512	113	212	99
549	141	277	136
554	80	243	163
563	129	245	116
652	108	254	146
685	187	386	199
698	191	384	193
702	154	334	180
714	155	388	233
715	167	374	207
722	190	408	218
723	184	344	160
727	205	390	185
782	211	351	140

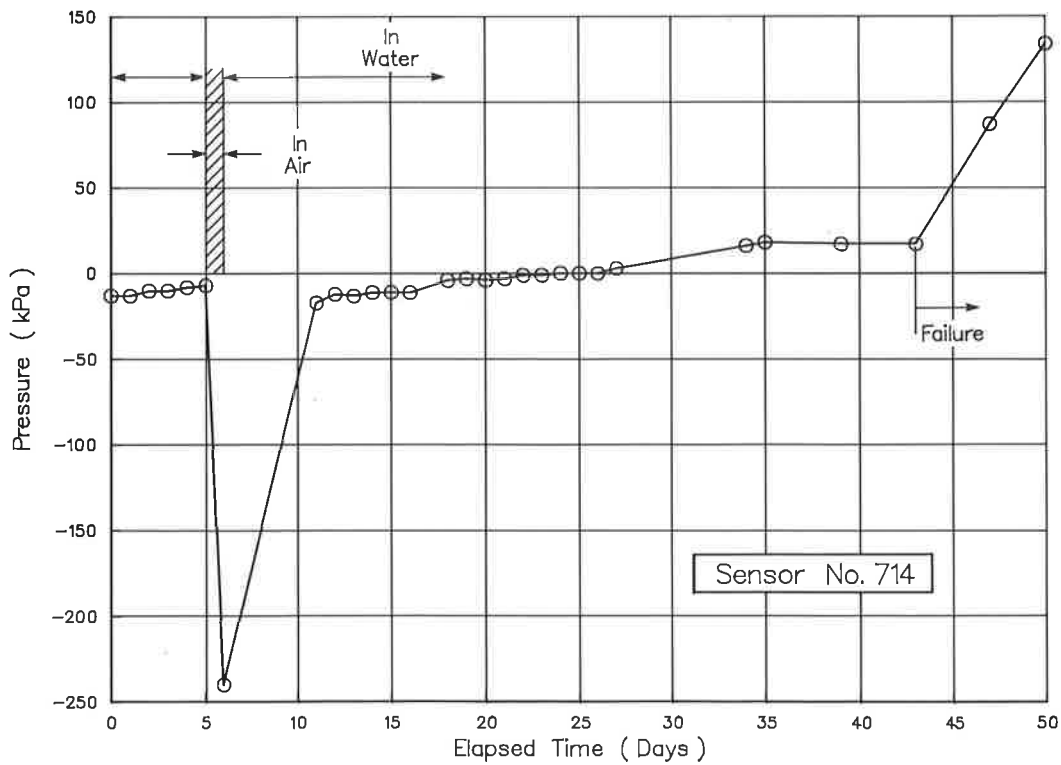

FIGURE 5 Failure of Sensor 714 due to prolonged submergence.

unreasonably high negative matric suction for a period of time before the sensor became inoperative. The failure may be attributed to moisture coming in contact with the electronics embedded in the sensor tip as a consequence of prolonged submergence. This phenomenon of failure after long-term submergence was noted by van der Raadt (10).

Attempts were made to recover failed sensors from the prolonged submergence tests by allowing the sensor tips to dry out. However, the failure was generally nonrecoverable. Those sensors that appeared to recover often displayed erratic behavior and were considered unreliable.

The question of sensor failure had implications regarding the inducement of complete saturated conditions in the sensor tip. As indicated earlier, it was difficult to ensure complete saturation of the sensor tip. It could be argued that the sensors could be subjected to backpressure to ensure saturation. However, it has been our experience that sensors subjected to positive pressure for extended periods often fail. The failure, as with long-term submergence, is believed to be related to water moving through the jacket covering the heating and temperature-sensing devices imbedded in the sensor tip. For this reason, backpressuring on the sensor tips should be avoided.

Effect of Changing Ambient Temperature

The influence of changing ambient temperature on the sensor outputs was evaluated by monitoring the response of the sensors using the data-acquisition system. Five sensors were submerged in a small glass container of water for about 20 days. These were monitored hourly for 2 days. After this initial monitoring period, the sensors were transferred from the small glass container to a large picnic cooler. The sensors were again monitored for about 1 day.

The daily temperature fluctuation in the laboratory was recorded for a week and consistently ranged from a high of approximately 24°C around 7:00 a.m. to a low of approximately 20°C around 11:00 p.m. During the initial portion of the test (left side of Figure 6) a fluctuation in sensor output was shown (sensors 698 and 512) that was similar in pattern to the diurnal temperature cycle in the laboratory. These fluctuations are believed to be caused by gradual heating and cooling of the water in the small container in response to changes in room temperature. This pattern was evident for all sensors in the test except 516, which gave near-constant output. The behavior of 516 may be due to entrapped air in the sensor tip or a malfunction in sensor electronics.

The magnitude of the output fluctuations was significantly reduced when the sensors were transferred from the small container to the large picnic cooler (see Figure 6). A significant reduction in sensor output was also evident. The decrease in magnitude of the fluctuations was believed to be due to the large volume of water providing a buffer against the influence of changing room temperature. The reduction in sensor output was most likely due to a difference in water temperature between containers. Unfortunately, water temperature was not monitored or controlled in this preliminary experiment, and therefore a temperature difference cannot be confirmed.

Phene et al. (7) state that the accuracy of measurements with thermal conductivity suction sensors is highly dependent upon the rate of change in temperature of the material in which they are placed. The range of sensor output fluctuations for the small and large containers (approximately 50 mV versus 25 mV) supports this statement. However, the question of temperature effects (both absolute and rate of change) requires a much more thorough investigation than the brief treatment described here.

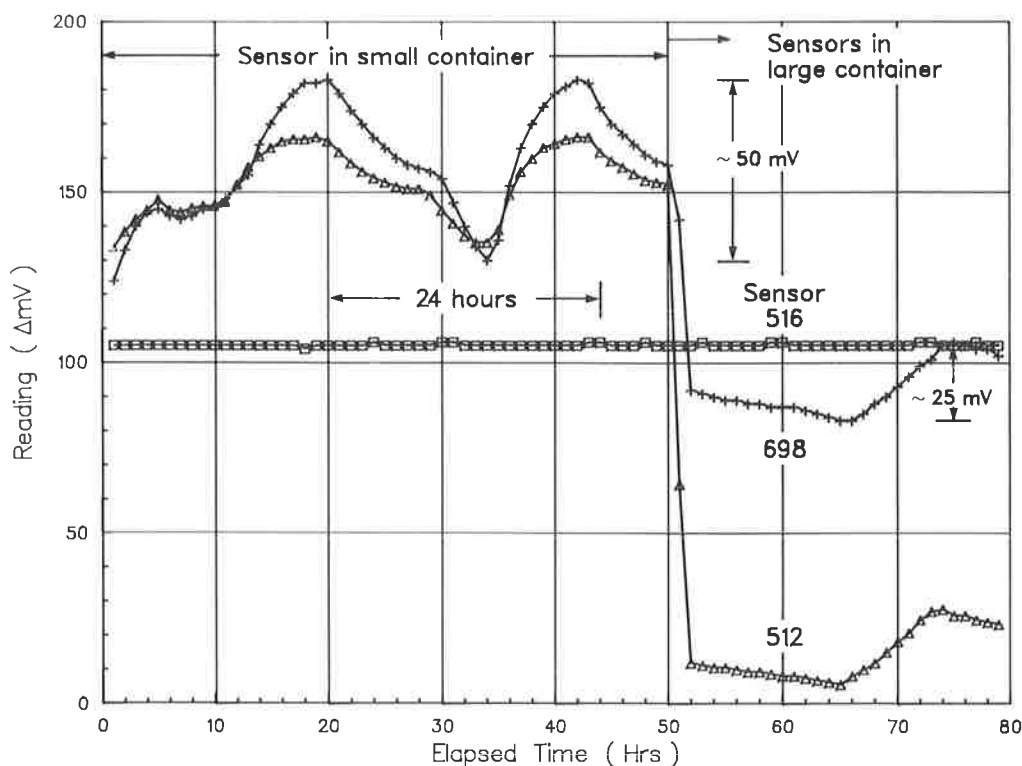

FIGURE 6 Effect of ambient temperature on sensor outputs.

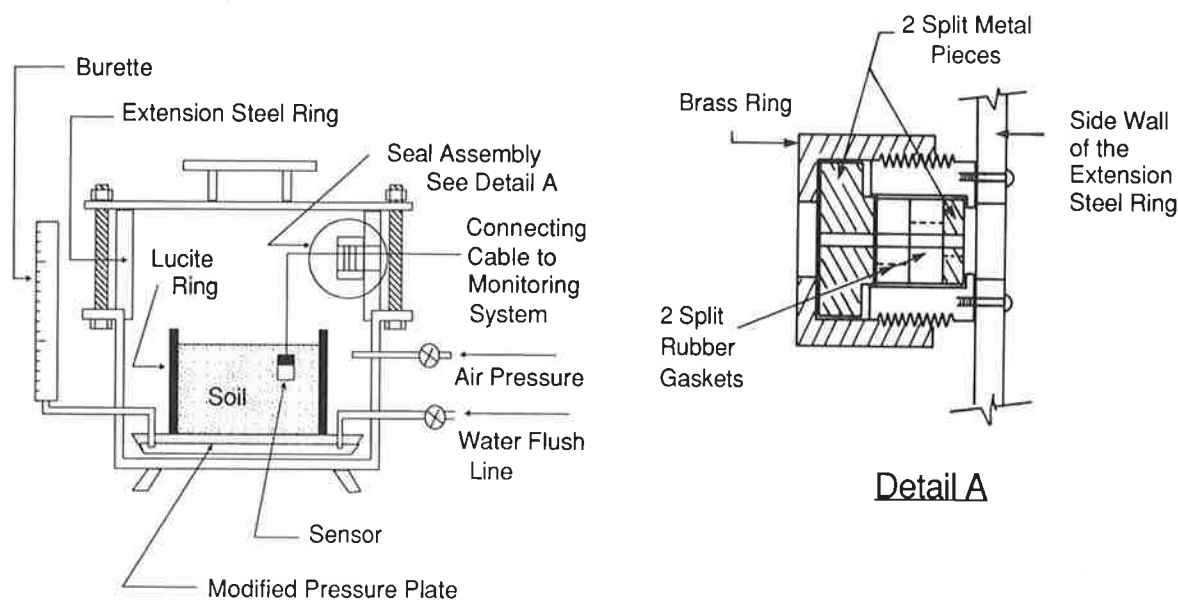

FIGURE 7 Pressure plate setup for calibrating thermal conductivity sensors.

Calibration of the Sensors

A calibration study was conducted on two groups of AGWA-II sensors using a commercially available, but modified, pressure plate extractor. These two groups of sensors were selected from different shipments from the manufacturer, the first group purchased in 1986 and the second in 1987.

The experimental setup for calibration of the sensors is shown in Figure 7. The setup consisted of a pressure plate extractor, a ceramic plate with a sheet-rubber backing, an insulated enclosure, and an Agwatronics sensor read-out device. The pressure plate extractor was modified by adding a steel extension ring to the pressure chamber. Twelve circular holes were drilled along the side wall of the extension ring; the holes were used to connect the sensors to the read-out device. The ceramic plate of the pressure plate extractor was also modified by installing an additional outlet as shown in Figure 7. With this modification, any diffused, entrapped air that accumulated beneath the ceramic plate could be removed by passing water through one of the outlets. An insulated enclosure was used to contain the entire pressure plate extractor in order to maintain the ambient temperature within the box at $\pm 0.5^\circ\text{C}$ of mean room temperature.

A calibration soil mix, which consisted of 10 percent Ottawa fine sand and 90 percent silt, was placed on an initially saturated ceramic plate inside a lucite cylinder (Figure 7). The mixture was prepared in a slurried form to ensure near-saturation of the sample. Initially saturated sensors were then placed through the openings around the extension steel ring and were installed by pushing their tips into the slurry mixture. The sensors were saturated by submerging the tip in de-aired water for about 2 days before calibration. The pressure chamber was closed and sequential increments of air pressure were applied to the mixture.

Matric suction is defined as the difference between the pore-air pressure, u_a , and the pore-water pressure, u_w . Matric suction is equal to $(u_a - u_w)$ regardless of the range of each of the component pressures. For the pressure plate apparatus, u_a is equal to the applied chamber pressure and u_w is main-

tained as atmospheric in the cavity below the pressure plate; hence, suction is established in the soil sample.

The water within the mixture was allowed to drain through the saturated ceramic plate in response to the applied air pressure. The response of each sensor was monitored periodically until equilibrium was achieved. This procedure was repeated for various applied air pressures. The monitoring was carried out using either the data-acquisition system or the hand-held meter, or both, for the calibration tests.

Calibration results of the two groups of sensors are summarized in Tables 2 and 3, which indicate that the calibration results were distinctly different for different shipments of the sensors. Typical calibration curves for the first and second group of sensors are shown in Figures 8 and 9, respectively. Figure 8 indicates that the calibration results determined in this study were different from those provided by the manufacturer in terms of both the calibration slope and the intercept for all suction values. The differences found between these two sets of calibration results largely account for the negative matric suction or positive pressure measurements displayed by the first group of sensors when they were submerged in water (see Figure 4). On the other hand, Figure 9 shows reasonable agreement between the calibration results determined in this study and those provided by the manufacturer for matric suctions ranging from 0 to 175 kPa.

Verbal communication with the sensor manufacturer subsequently revealed that the sensor tip porous medium had been changed between the two shipments. The change is proprietary information; however, the manufacturer indicated that the modification involved the cementing agent and particle size distribution of the material composing the sensor tip.

Deviations between the calibration results commenced at about 175 kPa and became more pronounced with increasing suctions for all the sensors calibrated in this study (Figures 8 and 9). The nonlinear response of the sensors was most likely related to the pore size distribution of the ceramic sensor tip. Phene et al. (7) showed that the shape of the response curve will vary with the type of material in the sensor tip. The

TABLE 2 SUMMARY OF CALIBRATION RESULTS USING HAND-HELD AGWAMETER: SENSORS PURCHASED IN 1986

Sensor Number	MANUFACTURER'S CALIBRATION		CALIBRATION STUDY			
	Slope	Intercept	Below Break Slope	Below Break Intercept	Above Break Slope	Above Break Intercept
480	1.758	-206.3	3.333	-433.3	13.333	-2199.9
512	1.581	-156.8	3.774	-449.1	11.111	-1700.0
516	1.605	-147.4	3.333	-366.7	10.000	-1450.0
549	1.357	-159.5	2.429	-315.7	6.250	-1137.5
554	1.498	-152.6	2.500	-287.5	3.846	-538.5
563	1.719	-219.4	2.941	-367.6	7.143	-1164.3
652	1.796	-156.8	2.308	-207.7	5.085	-661.0
667	1.879	-171.0	3.636	-367.3	9.375	-1218.7
685	1.296	-265.5	2.941	-688.2	5.970	-1611.9
698	1.701	-358.1	2.020	-410.1	7.692	-2061.5
701	1.738	-377.4	2.273	-511.4	5.085	-1383.0
711	3.796	-720.1	2.500	-500.0	5.000	-1200.0
714	1.406	-305.2	2.564	-574.4	4.839	-1248.4
715	1.859	-387.6	2.439	-500.0	4.110	-1006.8
722	2.351	-508.5	2.000	-450.0	4.225	-1140.8
723	7.364	-139.8	2.564	-466.7	6.250	-1387.5
727	1.879	-405.9	2.273	-509.1	6.250	-1737.5
736	1.769	-362.9	2.564	-543.6	4.124	-1002.1
782	1.728	-333.3	2.439	-485.4	6.818	-1690.9
833	4.111	-809.1	2.564	-500.0	8.333	-1999.9
859	3.439	-764.9	2.344	-510.9	4.688	-1185.9

$$y = mx + b$$

where:

y = soil suction in kPa

x = reading in ΔmV

m = slope

b = intercept

calibration curves measured at the University of Saskatchewan laboratory can be approximated by a bilinear curve as shown in Figures 8 and 9.

The slope of each calibration curve gives an indication of the sensitivity of the sensor to matric suction changes. For matric suctions less than 175 kPa, the slope is relatively flat compared with that above 175 kPa (Figures 8 and 9). A flat calibration curve implies a small change in matric suction corresponding to a relatively large change in sensor output. Therefore, the sensor is relatively sensitive to the changes in matric suction in the range from 0 to 175 kPa. On the other hand, a steep calibration curve implies a large change in matric suction with a small change in sensor output; therefore, sensor sensitivity to matric suctions is reduced above 175 kPa.

Implementation Testing of the Sensors

Suction measurements were conducted on 11 undisturbed specimens using the calibrated AGWA-II sensors. The soil

used was a highly plastic clay obtained from Sceptre, Saskatchewan, Canada. The soil has an average liquid limit of 84.8 percent and an average plasticity index of 52.3 percent. The soil is classified as CH on the Unified Soil Classification System.

Measurements were carried out using two sensors for each specimen. One sensor was initially saturated and the other was initially dry. The manufacturer makes no recommendations regarding the initial water content of the sensor tip. Lee and Fredlund (5) showed that unsaturated sensors responded faster than saturated ones.

The sensors were installed by inserting the tip into pre-drilled holes. The drill hole was prepared using a conventional wood bit driven by a hand drill. In order to ensure a good contact between the sensor and the soil, the size of the wood bit was chosen to produce a snug fit.

After the sensors were installed in the soil, the specimens were wrapped in a plastic film and covered with masking tape. The response of the sensors was monitored immediately and at various elapsed times after their installation using the hand-

TABLE 3 SUMMARY OF CALIBRATION RESULTS USING HAND-HELD AGWAMETER: SENSORS PURCHASED IN 1987

Sensor Number	MANUFACTURER'S CALIBRATION		CALIBRATION STUDY			
	Slope	Intercept	Below Break Slope	Below Break Intercept	Above Break Slope	Above Break Intercept
650	3.127	-338.3	3.390	-372.9	7.692	-1123.1
662	3.702	-353.3	3.279	-331.1	5.556	-561.1
709	2.378	-454.0	2.174	-423.9	5.479	-1397.3
716	1.849	-423.1	2.041	-469.4	4.412	-1235.3
726	2.220	-448.0	2.424	-509.1	5.063	-1316.5
733	2.166	-446.0	2.222	-477.8	4.348	-1126.1
861	2.259	-456.0	2.521	-504.2	7.692	-1984.6
865	2.751	-536.0	3.061	-581.6	11.765	-2788.2
868	2.006	-354.0	2.542	-508.5	6.944	-1743.1
870	2.268	-494.0	3.750	-825.0	9.756	-2487.8
872	2.221	-446.0	2.885	-600.0	6.349	-1580.9
887	2.631	-427.0	2.752	-423.8	8.160	-1550.4
897	2.991	-564.0	3.846	-750.0	10.811	-2486.5
899	2.976	-544.0	2.985	-552.2	6.452	-1367.7
900	2.745	-536.0	2.830	-532.1	5.714	-1222.9
901	2.700	-497.0	2.695	-498.6	6.154	-1347.7
902	3.084	-621.0	2.703	-545.9	7.692	-1830.8
904	3.127	-617.0	3.077	-612.3	7.407	-1681.5
905	2.040	-443.0	2.190	-473.0	8.696	-2339.1
906	2.633	-539.0	2.614	-535.9	6.557	-1554.1
907	2.963	-532.0	3.125	-562.5	10.526	-2273.7
909	3.077	-546.0	3.390	-593.2	8.511	-1761.7
911	2.336	-479.0	2.128	-393.6	7.407	-1770.4

$$y = mx + b$$

where:

- y = soil suction in kPa
- x = reading in ΔmV
- m = slope
- b = intercept

held meter. Monitoring was continued until the sensor had come into equilibrium with the soil.

A typical response of an initially saturated and a dry sensor, plotted in terms of indicated matric suction versus elapsed time, is shown in Figure 10. In general, the results showed that an initially saturated sensor underwent desorption and the suction increased with time until equilibrium was reached. On the other hand, an initially dry sensor underwent absorption and the suction value decreased with time until equilibrium was achieved. As shown in Figure 10, the equilibrium time required for the initially dry sensor was less than that for the initially saturated sensor. The equilibrium time for the absorption cycle was about 3 to 4 days, whereas the equilibrium time for the desorption cycle was considerably longer (Figure 10).

The effect of hysteresis on suction measurement is dem-

onstrated in Figure 10. The results indicated that the sensor that underwent a desorption cycle yielded a slightly lower suction value compared with a sensor that underwent an absorption cycle. A similar effect was reported by Lee and Fredlund (5). These results indicate that a small hysteretic effect was associated with the movement of moisture across the interface between the sensor tip and the soil. This may be related to air entrapment.

FULL-SCALE TEST

The calibrated AGWA-II sensors were used to measure matric suction in the subgrade soils of an indoor test track. The test track facility, which is located in Regina, Saskatchewan, Canada, is housed in a controlled environment. The test track

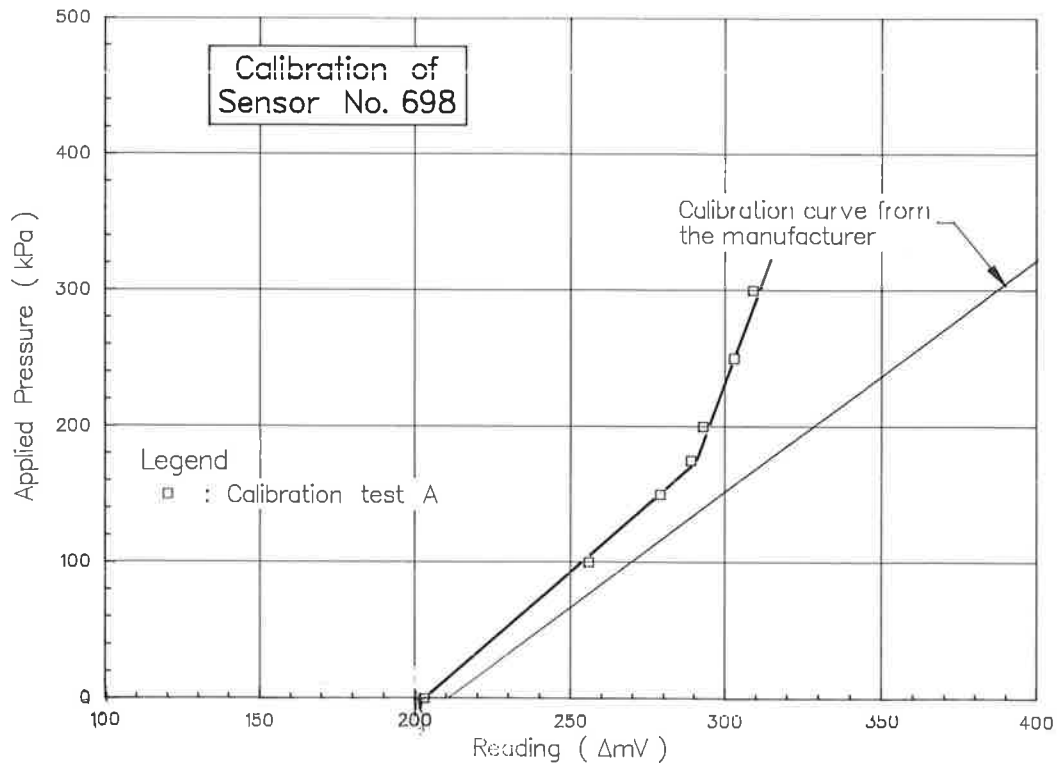

FIGURE 8 Calibration curve for Sensor 698.

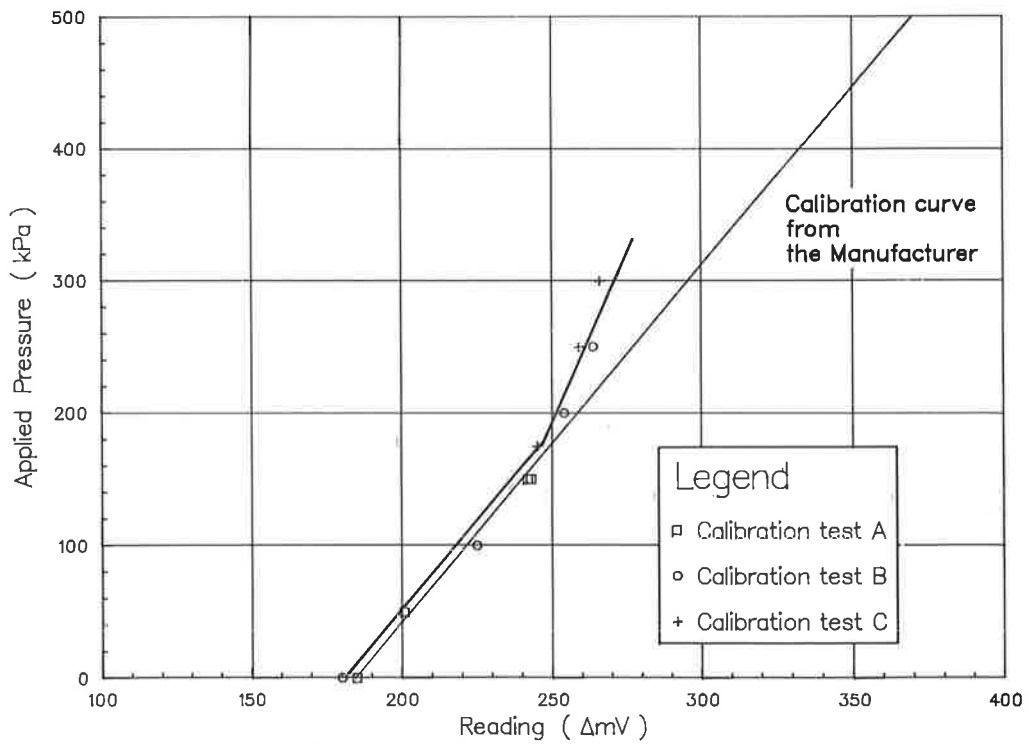

FIGURE 9 Calibration curve for Sensor 901.

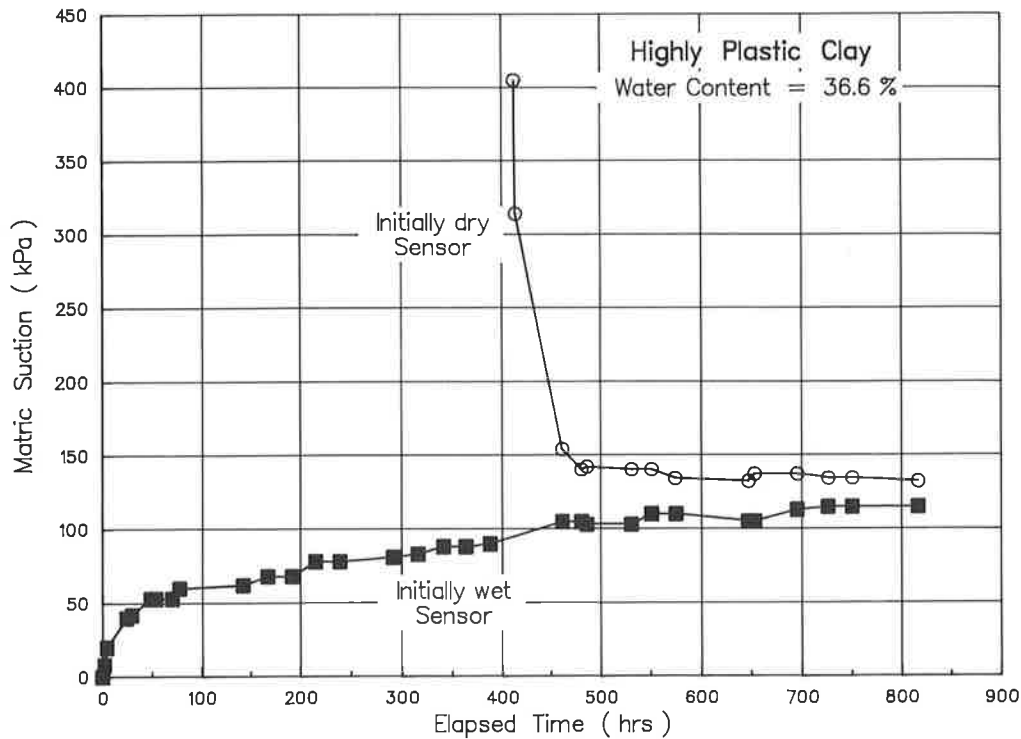

FIGURE 10 Laboratory measurements of matric suction on undisturbed soil specimen using the AGWA-II sensor.

facility can be used to simulate the effects of wet-dry and freeze-thaw cyclings on a pavement by controlling the ambient temperature and moisture.

Twenty-two sensors were installed in the subgrade of the test track, of which various sections are composed of Regina clay and glacial till. The sensors were all installed in an initially dry condition. The installation was carried out by making a slightly oversized access hole using a hand auger to a zone about 50 mm above the point at which the sensor was to be located. A modified drill bit with a long extension was then used to drill the last 50 mm to the diameter of the sensor tip. Before installation, the bottom of the hole was reamed and levelled using a specially designed plastic tube and cleaned using a vacuum cleaner. The sensor was mounted on a smaller-diameter plastic tube and inserted firmly into the hole. Extreme care was exercised at all times so as not to push the plastic tube too hard and thereby break the fragile sensor tip. The space around the lead wires of the sensor was backfilled with the cuttings that had been removed from the drill hole. This method of installation proved to be successful up to a maximum depth of 1.75 m.

Typical suction measurements on the Regina clay and glacial till subgrades are shown in Figure 11. The results indicate that the Regina clay had higher matric suction values than glacial till even though the Regina clay had a higher water content. It was believed, however, that suction measurements on the Regina clay might have reached the measurement limit of the sensor in view of the relatively high matric suction values. Previous calibrations of sensors were only conducted up to 300 kPa. Attempts were therefore made to extend the calibrations to higher matric suctions. The results show that the responses of the sensors are linear up to 400 kPa after a breaking point at about 175 kPa.

The sensors installed in the test track were monitored twice a day for more than 5 months using the hand-held meter. During this period, normal room air conditions (approximately 22°C) were maintained. Three of the 22 sensors failed during the test period. As shown in Figure 11, the measured matric suctions were essentially constant with time, showing little or no fluctuation after the equilibrium was achieved. In other words, the sensor proved to be stable in measuring matric suction over a relatively long period of time.

CONCLUSIONS

The following conclusions can be drawn as a result of the laboratory tests and the full-scale test conducted in this study:

1. The AGWA-II sensor was found to be relatively sensitive and accurate in measuring matric suction in the range of 175 kPa or lower under controlled temperature conditions. For matric suctions above 175 kPa, the sensitivity and accuracy for the sensor were reduced due to the nonlinear response of the sensors, as demonstrated in the calibration study. The results also indicated that the sensor output was relatively stable with time. The sensors that were used to measure matric suctions showed no significant drift over a period of more than 5 months.

2. The calibration curves for the AGWA-II sensors were bilinear, with a breaking point at about 175 kPa. Calibration curves supplied by the manufacturer for the first shipment of sensors were offset from those obtained in laboratory tests. However, good agreement was generally found between the calibration curves obtained in laboratory tests on the second shipment of sensors and those provided by the manufacturer.

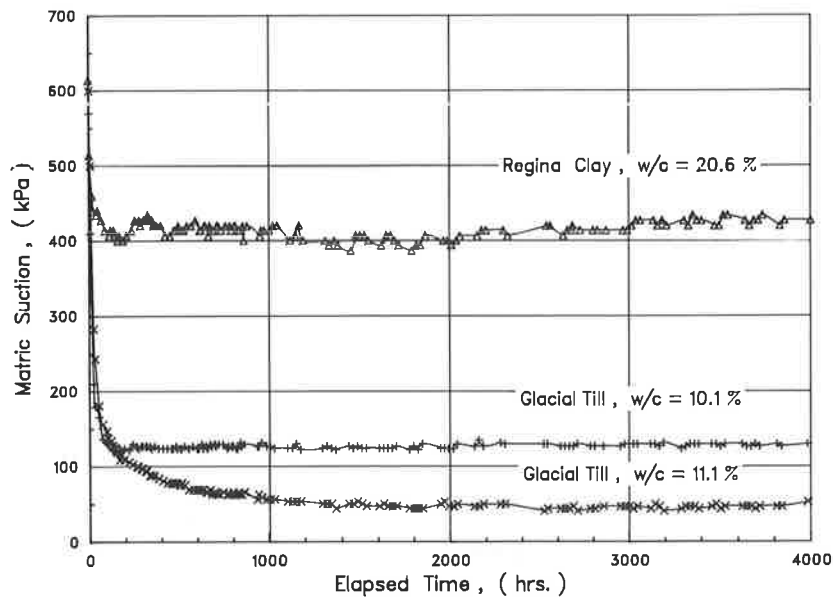

FIGURE 11 Measurements of matric suction on the subgrade of an indoor test track using the AGWA-II sensor.

for matric suctions ranging from 0 to 175 kPa. Deviation resulted above about 175 kPa because of the nonlinear characteristics of the sensors. The authors recommend that users of thermal conductivity sensors calibrate each sensor before use. The calibration procedure should involve a sufficient number of applied pressures in order to define the nonlinearities in the calibration curve.

3. The equilibrium time for sensors undergoing absorption was found to be about 3 to 4 days. The equilibrium time for the desorption cycle was considerably longer. The equilibrium time was dependent on the rate of moisture transfer between the sensor tip and the surrounding soil, which, in turn, was related primarily to the permeability of the soil. The results also show that the suction values measured during the absorption of the sensor were slightly higher than those measured during the desorption of the sensor.

4. The results indicate that the AGWA-II sensors have good potential for use in geotechnical engineering to measure soil suction in the laboratory and in situ. However, users of the thermal conductivity sensors should realize that some uncertainties and limitations may be associated with the sensors:

- The question of air movement into and out of the sensor tip under near-saturation conditions requires further investigation. It may in fact be beneficial to attempt to ensure that air has access to the sensor tip by means of a vent. This would be important only at low suction values less than one atmosphere. Despite this difficulty, the sensors appear to be quite sensitive even at suctions less than one atmosphere.

- The issue of temperature effects on sensor output must be resolved. The influence of changing temperature and absolute temperature must be quantified by careful laboratory testing, and methods should be devised for temperature correction, if required.

- Prolonged periods of submergence of the sensor in water require special caution. Although the sensors were shown to

be responsive to the wetting and drying cycles, they may fail as a consequence of prolonged periods of water submergence or exposure to positive pressure. This is believed to result from water contact with the sensor electronics. The failures are generally nonrecoverable. This may restrict their usefulness to measure matric suction of soils at or near saturation.

5. It would be desirable to validate the sensors in comparison with another suction-measuring device. The difficulty, however, is that no other sensor of similar range and sensitivity is available. As a result, much of the validation research must be indirect in nature.

ACKNOWLEDGMENTS

The work described in this paper was supported by the Saskatchewan Highways and Transportation Department. The authors would like to acknowledge the assistance and cooperation of Agwatronics, Inc. It is recognized that Agwatronics personnel have been carrying these sensors through a development phase, and the authors were pleased to have participated in the development work. The authors also gratefully acknowledge the assistance of A. Widger, Director of Geotechnical Materials Branch, Saskatchewan Highways and Transportation, and A. Ho, Research Engineer, University of Saskatchewan.

REFERENCES

1. M. E. Bloodworth and J. B. Page. Use of Thermistor for the Measurement of Soil Moisture and Temperature. *Soil Science Society of America Proceedings*, Vol. 22, 1957, pp. 11–15.
2. J. Krahn and D. G. Fredlund. On Total, Matric and Osmotic Suction. *Soil Science*, Vol. 114, No. 5, 1972, pp. 339–348.
3. B. Shaw and L. D. Bauer. Heat Conductivity as an Index of Soil Moisture. *Journal of the American Society of Agronomy*, Vol. 31, 1939, pp. 886–891.

4. B. Shaw and L. D. Bauer. An Electrothermal Method for Following Moisture Changes of the Soil In Situ. *Soil Science Society of America Proceedings*, Vol. 4, 1939, pp. 78–83.
5. R. K. C. Lee and D. G. Fredlund. Measurement of Soil Suction Using the MCS 6000 Sensor. *Proc., Fifth International Conference on Expansive Soils*, Adelaide, South Australia, 1984, pp. 50–54.
6. A. A. Curtis and C. D. Johnston. Monitoring Unsaturated Soil Water Conditions in Groundwater Recharge Studies. *Proc., International Conference on Measurement of Soil and Plant Water Status*, Vol. 1, Utah State University, 1987, pp. 267–274.
7. C. J. Phene, G. J. Hoffman, and S. L. Rawlins. Measuring Soil Matric Potential In-Situ by Sensing Heat Dissipation within a Porous Body: I. Theory and Sensor Construction. *Soil Science Society of America Proceedings*, Vol. 35, 1971, pp. 27–33.
8. C. J. Phene, G. J. Hoffman, and S. L. Rawlins. Measuring Soil Matric Potential In-Situ by Sensing Heat Dissipation within a Porous Body: II. Experimental Results. *Soil Science Society of America Proceedings*, Vol. 35, 1971, pp. 225–229.
9. C. J. Phene, C. P. Allee, and J. Pierro. Measurement of Soil Matric Potential and Real Time Irrigation Scheduling. *Proc., International Conference on Measurement of Soil and Plant Water Status*, Vol. 2, Utah State University, 1987, pp. 258–265.
10. P. van der Raadt. *Field Measurement of Soil Suction Using Thermal Conductivity Matric Potential Sensors*. M.Sc. thesis. University of Saskatchewan, Saskatoon, Saskatchewan, Canada, 1988, 245 pp.

Publication of this paper sponsored by Committee on Soils and Rock Instrumentation.