

IDEA

**Innovations Deserving
Exploratory Analysis Programs**

HIGHWAY

New IDEAS for Highway Systems

Highway IDEA Program Annual Report

DECEMBER 2021

The National Academies of
SCIENCES • ENGINEERING • MEDICINE



TRANSPORTATION RESEARCH BOARD

TRANSPORTATION RESEARCH BOARD 2021 EXECUTIVE COMMITTEE*

TRANSPORTATION RESEARCH BOARD 2021 EXECUTIVE COMMITTEE*

OFFICERS

CHAIR: **Susan A. Shaheen**, Professor, Civil and Environmental Engineering, and Co-Director, Transportation Sustainability Research Center, University of California, Berkeley

VICE CHAIR: **Nathaniel P. Ford, Sr.**, Chief Executive Officer, Jacksonville Transportation Authority, Jacksonville, FL

EXECUTIVE DIRECTOR: **Neil J. Pedersen**, Transportation Research Board

MEMBERS

Michael F. Ableson, CEO, Arrival Automotive–North America, Detroit, MI

Marie Therese Dominguez, Commissioner, New York State Department of Transportation, Albany

Ginger Evans, Chief Strategy Officer, CAG Holdings, Inc., Washington, D.C.

Michael F. Goodchild, Professor Emeritus, Department of Geography, University of California, Santa Barbara

Diane Gutierrez-Scaccetti, Commissioner, New Jersey Department of Transportation, Trenton

Susan Hanson, Distinguished University Professor Emerita, Graduate School of Geography, Clark University, Worcester, MA

Stephen W. Hargarten, Professor, Emergency Medicine, Medical College of Wisconsin, Milwaukee

Chris T. Hendrickson, Hamerschlag University Professor of Engineering Emeritus, Carnegie Mellon University, Pittsburgh, PA

S. Jack Hu, UGA Foundation Distinguished Professor of Engineering, Senior Vice President for Academic Affairs and Provost, University of Georgia, Athens

Randell Iwasaki, Leader, State and Local Transportation for Amazon Web Services, Walnut Creek, CA

Ashby Johnson, Executive Director, Capital Area Metropolitan Planning Organization (CAMPO), Austin, TX

William Kruger, Vice President, UPS Freight for Fleet Maintenance and Engineering, Richmond, VA

Julie Lorenz, Secretary, Kansas Department of Transportation, Topeka

Michael R. McClellan, Vice President–Strategic Planning, Norfolk Southern Corporation, Norfolk, VA

Patrick K. McKenna, Director, Missouri Department of Transportation, Jefferson City

Brian W. Ness, Director, Idaho Transportation Department, Boise

Craig E. Philip, Research Professor and Director, VECTOR, Department of Civil and Environmental Engineering, Vanderbilt University, Nashville, TN

Leslie S. Richards, General Manager, Southeastern Pennsylvania Transportation Authority (SEPTA), Philadelphia

Kevin J. Thibault, Secretary, Florida Department of Transportation, Tallahassee

James M. Tien, Distinguished Professor and Dean Emeritus, College of Engineering, University of Miami, Coral Gables, FL

Shawn Wilson, Secretary, Louisiana Department of Transportation and Development, Baton Rouge

EX OFFICIO MEMBERS

Michael R. Berube, Acting Deputy Assistant Secretary for Sustainable Transportation, U.S. Department of Energy, Washington, D.C.

Amit Bose, Deputy Administrator, Federal Rail Administration, Washington, D.C.

Carlos M. Bracerias, Executive Director, Utah Department of Transportation, Salt Lake City

Tristan Brown, Acting Administrator, U.S. Department of Transportation, Washington, D.C.

Steven Cliff, Acting Administrator, National Highway Traffic Safety Administration, Washington, D.C.

Richard Corey, Executive Officer, California Air Resources Board, Sacramento

Stephen M. Dickson, Administrator, Federal Aviation Administration, U.S. Department of Transportation, Washington, D.C.

Nuria I. Fernandez, Administrator, Federal Transit Administration, Washington, D.C.

LeRoy Gishi, Chief, Division of Transportation, Bureau of Indian Affairs, U.S. Department of the Interior, Germantown, MD

Martha R. Grabowski, McDevitt Distinguished Chair in Information Systems, Le Moyne College, Syracuse, NY, and Senior Research Scientist, Rensselaer Polytechnic Institute, Troy, NY

William H. Graham, Jr. (Major General, U.S. Army), Deputy Commanding General for Civil and Emergency Operations, U.S. Army Corps of Engineers, Washington, D.C.

John T. Gray II, Senior Vice President, Policy and Economics, Association of American Railroads, Washington, D.C.

Robert Hampshire, Deputy Assistant Secretary for Research and Technology, U.S. Department of Transportation, Washington, D.C.

Meera Joshi, Deputy Administrator, Federal Motor Carrier Safety Administration, Washington, D.C.

Eleftheria Kontou, Assistant Professor, University of Illinois, Urbana-Champaign, Urbana, and Chair, TRB Young Members Coordinating Council

Stephanie Pollack, Acting Administrator, Federal Highway Administration, U.S. Department of Transportation, Washington, D.C.

Craig A. Rutland, U.S. Air Force Pavement Engineer, U.S. Air Force Civil Engineer Center, Tyndall Air Force Base, FL

Karl L. Schultz (Admiral, U.S. Coast Guard), Commandant, U.S. Coast Guard, Washington, D.C.

Karl Simon, Director, Transportation and Climate Division, U.S. Environmental Protection Agency, Washington, D.C.

Paul P. Skoutelas, President and CEO, American Public Transportation Association, Washington, D.C.

Katherine F. Turnbull, Executive Associate Director and Regents Fellow Research Scientist, Texas A&M Transportation Institute, College Station

Jim Tymon, Executive Director, American Association of State Highway and Transportation Officials, Washington, D.C.

* Membership as of November 2021.

Publications of the IDEA Programs are available on the internet at <https://www.trb.org/IDEAProgram/IDEAProgram.aspx>.

© 2021 National Academy of Sciences. All rights reserved.

Transportation Research Board publications may be ordered directly from the TRB Business Office (202-334-3213), through the internet at trb.org, or by annual subscription through organization or individual affiliation with TRB. Affiliates and library subscribers are eligible for substantial discounts.

For further information, contact the Transportation Research Board Business Office, 500 Fifth St., NW, Washington, DC 20001 (telephone 202-334-3213; fax 202-334-2519; or email TRBsales@nas.edu).

NEW IDEAS FOR HIGHWAY SYSTEMS

Annual Report of the Highway IDEA Program

NCHRP 20-30, "Ideas Deserving Exploratory Analysis" (IDEA)

The National Cooperative Highway Research Program (NCHRP) is sponsored by the individual state departments of transportation of the American Association of State Highway and Transportation Officials (AASHTO), in cooperation with the Federal Highway Administration (FHWA). NCHRP is administered by the Transportation Research Board (TRB), part of the National Academies of Sciences, Engineering, and Medicine.

DECEMBER 2021

The National Academies of
SCIENCES • ENGINEERING • MEDICINE



TRANSPORTATION RESEARCH BOARD

NATIONAL COOPERATIVE HIGHWAY RESEARCH PROGRAM

NCHRP 20-30 IDEAS DESERVING EXPLORATORY ANALYSIS (IDEA) PANEL 2021

Chair

Catherine C. McGhee
*Director, Virginia Transportation Research Council
Virginia DOT*

Members

Ahmad Abu-Hawash
*Chief Structural/Bridge Engineer
Iowa DOT*

Farhad Ansari
*Associate Vice Chancellor for Research
University of Illinois at Chicago*

Nicholas L. Burmas
*Chief, Office of Materials and
Infrastructure
California DOT*

Paul J. Carlson
*Chief Technology Officer
Road Infrastructure, Inc.*

Allison R. Hardt
*Deputy Director, Policy & Research
Maryland State Highway Administration*

Eric E. Harm
*Consultant
Windermere, FL*

Denise M. Inda
*Chief Traffic Operations Engineer
Nevada DOT*

Patricia A. Leavenworth
*Deputy Administrator/Chief Engineer
Massachusetts DOT*

J. Michelle Owens
*State Research and Development Engineer
Alabama DOT*

Emily Parkany
*Research Manager
Vermont Agency of Transportation*

Kevin J. Pete
*Director, Research and Technology Implementation
Texas DOT*

Rachael B. Sack
*Director, U.S. DOT Small Business Innovation
Research Program
Volpe National Transportation Systems Center*

James M. Sime
*Consultant
East Hartford, CT*

Joseph Wartman
*H.R. Berg Professor of Civil Engineering
University of Washington*

FHWA Liaison

Mary Huie
*Manager, Innovation Management and Technology
Transfer
Turner-Fairbank Highway Research Center*

AASHTO Liaison

Glenn Page
Associate Program Director, Project Delivery

TRB Liaison

Richard A. Cunard
*Engineer of Traffic & Operations
Transportation Research Board
Technical Activities Division*

IDEA Staff

Inam Jawed
*Senior Program Officer
NCHRP IDEA Program, Cooperative Research
Programs*

Demisha Williams
*Senior Program Assistant
Cooperative Research Programs*

NCHRP Staff

Christopher J. Hedges
Director, Cooperative Research Programs

Lori L. Sundstrom
*Deputy Director, Cooperative Research Programs
and Manager, NCHRP*

Waseem Dekelbab
Associate Program Manager, NCHRP

■

The National Academies of SCIENCES • ENGINEERING • MEDICINE

The **National Academy of Sciences** was established in 1863 by an Act of Congress, signed by President Lincoln, as a private, non-governmental institution to advise the nation on issues related to science and technology. Members are elected by their peers for outstanding contributions to research. Dr. Marcia McNutt is president.

The **National Academy of Engineering** was established in 1964 under the charter of the National Academy of Sciences to bring the practices of engineering to advising the nation. Members are elected by their peers for extraordinary contributions to engineering. Dr. John L. Anderson is president.

The **National Academy of Medicine** (formerly the Institute of Medicine) was established in 1970 under the charter of the National Academy of Sciences to advise the nation on medical and health issues. Members are elected by their peers for distinguished contributions to medicine and health. Dr. Victor J. Dzau is president.

The three Academies work together as the **National Academies of Sciences, Engineering, and Medicine** to provide independent, objective analysis and advice to the nation and conduct other activities to solve complex problems and inform public policy decisions. The National Academies also encourage education and research, recognize outstanding contributions to knowledge, and increase public understanding in matters of science, engineering, and medicine.

Learn more about the National Academies of Sciences, Engineering, and Medicine at www.nationalacademies.org.

The **Transportation Research Board** is one of seven major programs of the National Academies of Sciences, Engineering, and Medicine. The mission of the Transportation Research Board is to provide leadership in transportation improvements and innovation through trusted, timely, impartial, and evidence-based information exchange, research, and advice regarding all modes of transportation. The Board's varied activities annually engage about 8,000 engineers, scientists, and other transportation researchers and practitioners from the public and private sectors and academia, all of whom contribute their expertise in the public interest. The program is supported by state transportation departments, federal agencies including the component administrations of the U.S. Department of Transportation, and other organizations and individuals interested in the development of transportation.

Learn more about the Transportation Research Board at www.nationalacademies.org/trb/transportation-research-board.

TABLE OF CONTENTS

Introduction	1
--------------	---

SECTION 1: Completed IDEA Projects

Project	Page
1 <i>On-Line Real-Time Measurement and Control of Aggregate Gradation in Asphalt Plants</i> Felix ALBA Consultants Inc., Murray, Utah STAKER Paving and Construction Company, Salt Lake City, Utah	4
2 <i>A Method for Measuring Water-Stripping Resistance of Asphalt/Siliceous Aggregate Mixtures</i> National Institute of Standards and Technology, Gaithersburg, Maryland	5
3 <i>Guidelines for Low-Cost Sprayed-Zinc Galvanic Anode for Controlling Corrosion of Reinforcing Steel in Marine Bridge Substructures</i> University of South Florida, Tampa, Florida Florida Department of Transportation, Gainesville, Florida	6
4 <i>Exploring the Feasibility of Replacing Latex with Asphalt Emulsion for Use in Bridge Deck Overlays</i> Purdue University, West Lafayette, Indiana	7
5 <i>Magnetic Resonance for In Situ Determination of Asphalt Aging and Moisture Content</i> Southwest Research Institute, San Antonio, Texas	8
6 <i>Excogitated Composite Multifunctional Layer for Pavement Systems</i> University of Illinois, Urbana-Champaign, Illinois	9
7 <i>Strategy for Coating Structural Steel without Stringent Blasting Regulations</i> Steel Structures Painting Council, Pittsburgh, Pennsylvania	10
8 <i>Conservation Traffic Control Load Switch</i> CLS Incorporated, Westerville, Ohio	11
9 <i>Corrosion-Resistant Steel Reinforcing Bars</i> University of Kansas, Lawrence, Kansas	12
10 <i>Metallic Coating for Corrosion Protection of Steel Rebars</i> SRI International, Menlo Park, California	13
11 <i>Rehabilitation of Steel Bridges Through the Application of Advanced Composite Materials</i> University of Delaware, Newark, Delaware	14
12 <i>Advanced Testing of an Automatic Nondestructive Evaluation System for Highway Pavement Surface Condition Assessment</i> Illinois Institute of Technology, Chicago, Illinois	15

Project	Page
13 <i>New Additive for Improved Durability of Concrete</i> University of Connecticut, Storrs, Connecticut Todd Chemical Company, Cheshire, Connecticut	16
14 <i>Unreinforced, Centrally Prestressed Concrete Columns and Piles</i> Florida Atlantic University, Boca Raton, Florida	17
15 <i>Portable Laser Road Crew Warning System</i> Lockheed Martin Corporation, Manassas, Virginia	18
16 <i>Laser Removal of Paint on Pavement</i> MOXTEX Incorporated, Orem, Utah	19
17 <i>Self-Contained Portable Device for SHRP Binder Testing: Field QC/QA Testing with the Duomorph</i> University of Illinois, Urbana-Champaign, Illinois	20
18 <i>New Principles of Design for Cutting Tools to Repair and Remove Pavements Based on the Effect of Lateral Propagation of Cracks Under Contact Loading</i> POTOK Centre, Kiev, Ukraine	21
19 <i>Aluminum Bronze Alloy for Corrosion-Resistant Rebar</i> Man-Tech Development, Inc., Mansfield, Texas	22
20 <i>Carbon Dioxide (Dry Ice) Cleaning to Remove Highway Road Markings and Stripes</i> Tomco Equipment Company, Loganville, Georgia	23
21 <i>Development of LED Light Source for Traffic Control Devices</i> The Last Resource Inc., Bellefonte, Pennsylvania	24
22 <i>Use of Phase Change Materials to Prevent Overnight Freezing of Bridge Decks</i> University of Dayton Research Institute, Dayton, Ohio	25
23 <i>Lead-Based Paint Removal from Steel Structures</i> EMEC Consultants, Export, Pennsylvania	26
24 <i>Fiber-Optic Strain Sensor System for Long-Term Monitoring of Highway Structures</i> Simula Government Products Inc., Phoenix, Arizona	27
25 <i>Basalt Fiber Composite Reinforcement for Concrete</i> Research and Technology Inc., Madison, Wisconsin	28
26 <i>Conservation Control Load Switch Operational Tests</i> CLS Incorporated, Westerville, Ohio	29
27 <i>Automated Bridge Deck Anti- and Deicing System</i> University of Utah, Salt Lake City, Utah	30

Project	Page
28 <i>Corrosion-Resistant Low-Carbon Steels for Concrete Reinforcement</i> University of California, Berkeley, California	31
29 <i>Superelasticity-Based Materials for Bridge Rehabilitation</i> DPD Inc., Lansing, Michigan Michigan State University, East Lansing, Michigan	32
30 <i>Rapid Replacement Composite Bridge No. 1</i> Kansas Structural Composites Inc., Russell, Kansas	33
31 <i>Cost-Effective Microwave Sensor to Detect Highway Road Conditions</i> University of Wyoming, Laramie, Wyoming	34
32 <i>Testing and Trial Deployment of a Cost-Effective and Real-Time Asphalt Pavement Quality Indicator System</i> TransTech Systems Inc., Latham, New York	35
33 <i>Evaluation of a New Rehabilitation Technology for Bridge Piers with Composite Materials</i> West Virginia University, Morgantown, West Virginia	36
34 <i>Highway Guardrail Infrastructure: Safer Terminal Designs</i> Duke University, Durham, North Carolina	37
37 <i>In-Service Repair of Highway Bridges and Pavements by Internal Time Release of Repair Chemicals</i> Illinois Universities Transportation Research Consortium, Chicago, Illinois	38
38 <i>Paint Removal from Steel Structures: Testing and Demonstration of ElectroStrip™ Process</i> EMEC Consultants, Export, and New Kensington, Pennsylvania	39
40 <i>Estimating Truck Attributes from Bridge Strain Data Using Neural Networks</i> University of Florida, Gainesville, Florida	40
41 <i>Field Testing with the Duomorph: A Self-Contained Portable Device for SHRP Binder Testing</i> University of Illinois, Urbana-Champaign, Illinois	41
42 <i>Dual-Core Fiber Optic WIM System</i> University of Connecticut, Storrs, Connecticut	42
43 <i>Robotic System for Underwater Bridge Inspection and Scour Evaluation</i> Kansas State University, Manhattan, Kansas	43
44 <i>Roller-Mountable Asphalt Pavement Quality Indicator Using Differential Microwave Signals</i> Iowa State University, Ames, Iowa	44
45 <i>Performance Evaluation of Basalt Fibers and Composite Rebars as Concrete Reinforcement</i> Research and Technology Inc., Madison, Wisconsin South Dakota School of Mines and Technology, Rapid City, South Dakota	45

Project	Page
46 <i>Testing, Evaluation, and Installation of Fiber-Reinforced Polymer Honeycomb Composite Panels in Bridge Deck Applications</i> Kansas Structural Composites Inc., Russell, Kansas	46
47 <i>Pavement Quality Indicator: Field Operational Testing and Product Transfer</i> TransTech Systems, Latham, New York	47
48 <i>Field Trial of Shape Memory-Based Rehabilitation System</i> DPD, Inc., Lansing, Michigan Michigan State University, East Lansing, Michigan	48
49 <i>Automation of Legends Painting</i> Pavement Marking Technologies Inc., Menlo Park, California	49
50 <i>Damper Systems for Suppression of Bridge Stay Cable Vibrations</i> Construction Technology Laboratories Inc., Skokie, Illinois	50
51 <i>Application of Advanced Composites to Steel Bridge Retrofitting</i> University of Delaware, Newark, Delaware	51
52 <i>Environmentally Friendly Passivating Coatings for Steel Rebars</i> Neely Industries Inc., Butler, Pennsylvania University of South Florida, Tampa, Florida Florida Department of Transportation, Gainesville, Florida University of Rhode Island, South Kingstown, Rhode Island	52
54 <i>Novel Approach for Predicting Remaining Life of Concrete Bridge Structures</i> University of Arizona, Tucson, Arizona	53
55 <i>Design, Development, and Verification of an Advanced In Situ Shear Strength Test Facility for Asphalt Concrete Pavements</i> Carleton University, Ottawa, Ontario, Canada	54
56 <i>Bridge Inspection with Serpentine Robots</i> Carnegie Mellon University, Pittsburgh, Pennsylvania	55
57 <i>Stabilization of Landslides Using Horizontal Wick Drains</i> Colorado School of Mines, Golden, Colorado University of Missouri, Rolla, Missouri	56
58 <i>Long Gauge-Length Interferometric Fiber-Optic Sensors for Condition Assessment of Bridge Structures</i> Pennsylvania State University, University Park, Pennsylvania	57
59 <i>Control Systems for Live Load and Live Load Effects on Bridges</i> University of Michigan, Ann Arbor, Michigan	58

Project	Page
60 <i>The Hybrid-Composite Beam System</i> Teng and Associates, Inc., Chicago, Illinois	59
61 <i>The Pavement Thickness Density Meter</i> INFRASENSE Inc., Arlington, Massachusetts	60
62 <i>A New Technique for Characterizing Pavement Surface Profiles and Textures</i> Texas A&M University, College Station, Texas	61
63 <i>Manufacture and Testing of a Filament-Wound Composite Bridge Superstructure</i> University of Illinois, Urbana-Champaign, Illinois	62
64 <i>Quantitative Characterization of Asphalt Concretes Using High-Resolution X-Ray Computed Tomography (CT)</i> University of Texas, Austin, Texas	63
65 <i>Application of Shape Memory Alloys in Seismic Rehabilitation of Bridges</i> Georgia Institute of Technology, Atlanta, Georgia	64
66 <i>Development of An Innovative Connector System for Fiber-Reinforced Polymer Bridge Decks to Steel Stringers</i> West Virginia University, Morgantown, West Virginia	65
67 <i>All Composite Bridge Sidewalk</i> Foster-Miller Inc., Waltham, Massachusetts E. T. Techtonics Inc., Philadelphia, Pennsylvania	66
68 <i>Geocomposite Capillary Barrier Drain for Limiting Moisture Changes in Pavement Subgrades and Base Courses</i> University of New Mexico, Albuquerque, New Mexico	67
69 <i>Development of a Conductivity Spectrum Probe (CSP) for Predicting Chloride Permeability in Concrete</i> INFRASENSE Inc., Arlington, Massachusetts	68
70 <i>Flamespray Coating as an Environmentally Acceptable Pavement Marking Technique</i> Research Triangle Institute, Durham, North Carolina	69
71 <i>Implementation of Tuned Dampers for Suppression of Bridge Stay Cable Vibrations</i> Construction Technology Laboratories Inc., Skokie, Illinois University of Wisconsin, Milwaukee, Wisconsin	70
72 <i>Improved Filtration of Wash Water Generated during Bridge Maintenance Painting</i> Georgia Tech Research Institute, Atlanta, Georgia	71
73 <i>Development of a Screed to Detect and Measure Segregation of HMA Pavements</i> Auburn University, Auburn, Alabama	72

Project	Page
74 <i>Adhesion Tool For Overcoating Risk-Reduction Analysis</i> Corrpro Companies Inc., Arlington, Virginia	73
75 <i>Automated Mobile Highway Sign Retroreflectivity Measurement</i> University of Missouri-Rolla, Rolla, Missouri	74
76 <i>Stabilization of Landslides Using Horizontal Wick Drains</i> Colorado School of Mines, Golden, Colorado University of Missouri, Rolla, Missouri	75
77 <i>The Development of a Computer Controlled Image Analysis System for Measuring Aggregate Shape Properties</i> Washington State University, Pullman, Washington	76
78 <i>Aggregate Shape Characterization Using Digital Image Processing</i> University of Missouri, Rolla, Missouri	77
79 <i>Concrete Road Recycler—Hammer-Anvil Test Rig</i> Road Processing Resources Inc., Vail, Colorado	78
80 <i>Development of a Generic Connector System for Attaching Conventional Bridge Rails to Fiber-Reinforced Polymer Composite Bridge Decks</i> Kansas Structural Composites, Inc., Russell, Kansas	79
81 <i>Automated Real-Time Pavement Crack Detection and Classification System</i> Utah State University, Logan, Utah Utah Department of Transportation, Salt Lake City, Utah	80
82 <i>Development and Field Verification of Torsional Cylindrical Impulse Shear Test</i> Dynamic In Situ Geotechnical Testing Inc., Lutherville, Maryland	81
83 <i>Testing of a Wide Area Optical Surface Contamination Detection System for Public Transportation Applications</i> Sensor Systems, Goodrich Corporation, Burnsville, Minnesota	82
84 <i>Development of a Fracture Mechanics-Based Asphalt Binder Test for Low-Temperature Performance Prediction</i> Queen's University, Kingston, Ontario, Canada University of Minnesota, Minneapolis, Minnesota	83
85 <i>Waterproofing Concrete Highways</i> Southwest Texas State University, San Marcos, Texas University of Texas, Austin, Texas	84
86 <i>Advanced Concept Concrete Using Basalt Fiber/BF Composite Rebar Reinforcement</i> Research & Technology Corp., Madison, Wisconsin	85

Project	Page
87 <i>An In Situ Shear Test Facility for Asphalt Concrete Pavements</i> Carleton University, Ottawa, Canada	86
88 <i>Automated Pavement Distress Survey Through Stereovision</i> University of Arkansas, Fayetteville, Arkansas	87
89 <i>U.S.-Specific Self-Compacting Concrete for Bridges</i> University of Michigan, Ann Arbor, Michigan	88
90 <i>Robotic Highway Safety Markers</i> University of Nebraska, Lincoln, Nebraska	89
91 <i>Application of Shape Memory Alloys In Seismic Rehabilitation of Bridges</i> Georgia Institute of Technology, Atlanta, Georgia	90
92 <i>Development of an Adaptive Damper For Cable Vibration Control</i> Louisiana State University, Baton Rouge, Louisiana	91
93 <i>Advanced Relocatable Traffic Sensor System (ARTS)</i> The Scientex Corporation, Alexandria, Virginia	92
94 <i>Liquefaction Mitigation Using Vertical Drainage: Full-Scale Testing</i> Brigham Young University, Provo, Utah	93
95 <i>Concrete Road Recycler—Hammer-Anvil Test</i> Road Processing Resources Inc., Vail, Colorado	94
96 <i>Using Ultrasound of MHz Frequency for Testing Concrete</i> Optimum Engineering Research, Lansdowne, Pennsylvania	95
97 <i>Fiber-Reinforced Plastics for Seismic Bridge Restrainers</i> University of Nevada, Reno, Nevada	96
98 <i>Void Detection in Post-Tensioning Ducts using Time-Domain Reflectometry</i> University of Delaware, Newark, Delaware	97
99 <i>Development of Asphalt Binder Cracking Device</i> Ohio University, Athens, Ohio	98
100 <i>Evaluation of AL-ZN-IN Alloy for Galvanic Cathodic Protection of Bridge Decks</i> Corrpro Companies, Inc., West Chester, Pennsylvania	99
101 <i>Active Heating Infrared Thermography for Detection of Subsurface Bridge Deck Deterioration</i> Infrasense Inc., Arlington, Massachusetts	100

Project	Page
102 <i>Nondestructive Evaluation Method for Determination of Internal Grout Conditions inside Bridge Post-tensioning Ducts using Rolling Stress Waves for Continuous Scanning</i> Olson Engineering Inc., Wheat Ridge, Colorado	101
103 <i>Liquefaction Mitigation Using Vertical Composite Drains: Full-Scale Testing for Pile Applications</i> Brigham Young University, Provo, Utah	102
104 <i>Improved Low-Temperature and Fatigue-Performance Grading of Asphalt Binders</i> Queen's University, Kingston, Ontario, Canada	103
105 <i>Evaluation of New Methods to Measure Water-to-Cement Ratio of Fresh Concrete</i> Nomadies, Inc., Stillwater, Oklahoma Strategic Solutions International, LLC, Stillwater, Oklahoma Engius, LLC, Stillwater, Oklahoma	104
106 <i>Automated Real-Time Pavement Crack Detection and Classification</i> Utah State University, Logan, Utah	105
107 <i>Mobile Geophysical Technology: A Subsurface Scoping Tool for Reducing Unforeseen Roadblocks in Project Delivery</i> Argus Technologies Inc., Dixon, California	106
108 <i>Pilot Study of 3D-Centric Modeling Processes for Integrated Design and Construction of Highway Bridges</i> State University of New York, Buffalo, New York	107
109 <i>Smart Array Antenna for Nondestructive Evaluation of Fiber-Reinforced Polymer-Wrapped Concrete Bridge Members</i> Newport Sensors Inc., Irvine, California	108
111 <i>Automated Pavement Distress Survey Through Stereovision</i> University of Arkansas, Fayetteville, Arkansas	109
112 <i>Cone Penetrometer Equipped with Piezoelectric Sensors for Measurement of Soil Properties in Highway Pavement</i> Case Western Reserve University, Cleveland, Ohio	110
113 <i>Geocomposite Capillary Barrier Drain for Limiting Moisture Changes in Pavements</i> University of New Mexico, Albuquerque, New Mexico US Army Cold Regions and Research Engineering Laboratory, Hanover, New Hampshire Minnesota Department of Transportation, Minneapolis, Minnesota	111
114 <i>Relationship of Asphalt Pavement Microtexture Using Image Analysis of Aggregate Shape</i> Texas A&M University, College Station, Texas	112

Project	Page
115 <i>Development of a Second Generation Detection-Control System for Safer Operation of High-Speed Signalized Intersections</i> Texas Transportation Institute, College Station, Texas	113
116 <i>Seismic Response of Bridge Columns with Engineered Cementitious Composites and Shape Memory Alloys in Plastic Hinge Zone</i> University of Nevada, Reno, Nevada	114
117 <i>Self-Powered Sensors and Actuators for Bridges</i> Clarkson University, Potsdam, New York	115
118 <i>The BCD: A New Instrument for Compaction Control</i> Texas A&M University, College Station, Texas	116
119 <i>Three-Dimensional Digital Imaging for the Identification, Evaluation, and Management of Unusable Highway Slopes</i> Split Engineering, LLC, Tucson, Arizona University of Utah, Salt Lake City, Utah	117
120 <i>Active Sensing for Online Highway Bridge Monitoring</i> Carnegie Mellon University, Pittsburgh, Pennsylvania	118
121 <i>Using Image Pattern Recognition Algorithms for Processing Video Log Images to Enhance Roadway Infrastructure Data Collection</i> Georgia Institute of Technology, Atlanta, Georgia	119
122 <i>Digital Specimen and Multi-Function Digital Tester Technique for Performance Evaluation of Asphalt Mixes</i> Virginia Polytechnic Institute and State University, Blacksburg, Virginia	120
123 <i>Long-Term Remote Sensing System for Bridge Piers</i> University of Missouri at Columbia, Missouri Fuchs Consulting Inc., Leesburg, Virginia	121
124 <i>Novel Optical Fiber Sensors for Monitoring Bridge Structural Integrity</i> Newport Sensors Inc., Irvine, California	122
125 <i>An Autonomous and Self-Sustained Sensing System to Monitor Water Quality Near Highways</i> Western Transportation Institute, Bozeman, Montana	123
126 <i>Developing Time Domain Reflectometry Instrument for Fresh Concrete and Early-Stage Concrete</i> Case Western Reserve University, Cleveland, Ohio	124
127 <i>Instrumentation to Aid in Steel Bridge Fabrication</i> Fuchs Consulting Inc., Leesburg, Virginia	125

Project	Page
128 <i>Underwater Fiber-Reinforced Polymer Repair of Corroding Piles Incorporating Cathodic Protection</i> University of South Florida, Tampa, Florida	126
129 <i>Developing an Embedded Wireless Strain/Stress/Temperature Sensors Platform for Highway Applications</i> Louisiana State University, Baton Rouge, Louisiana Louisiana Transportation Research Center, Baton Rouge, Louisiana	127
130 <i>Rapid, Self-Contained In Situ Permeameter for Field QC/QA of Pavement Base/Subbase Materials</i> Iowa State University, Ames, Iowa	128
131 <i>Smart Sensor for Autonomous Noise Monitoring</i> Applied Research Associates Inc., Littleton, Colorado	129
132 <i>Vehicle-Mounted Bridge Deck Scanner</i> Olsen Engineering Inc., Wheat Ridge, Colorado	130
133 <i>Development of a Simple Test to Determine the Low Temperature Creep Compliance of Asphalt Mixtures</i> University of Minnesota, Minneapolis, Minnesota	131
134 <i>Investigation of a Full-Lane Acoustic Scanning Method for Bridge Deck Nondestructive Evaluation</i> University of Illinois, Urbana-Champaign, Illinois Chased Technologies Pty Ltd., Perth, Australia	132
135 <i>Active Confinement of Bridge Piers Using Shape Memory Alloys</i> University of Illinois, Urbana-Champaign, Illinois	133
136 <i>Development of a Second Generation Neutron-Based Detector for Chloride in Concrete</i> University of Maryland, College Park, Maryland	134
137 <i>Real-Time Remote Evaluation of Post-Event Residual Capacity of Highway Bridges</i> Newport Sensors Inc., Irvine, California	135
138 <i>Scanning Capacitive Arrays for Real-Time, In-Situ Imaging of Density and Thickness in HMA Roadways</i> JENTEK Sensors Inc., Waltham, Massachusetts	136
139 <i>Development of a Sensing Methodology for Intelligent and Reliable Work-Zone Hazard Awareness</i> Georgia Institute of Technology, Atlanta, Georgia	137

Project	Page
140 <i>Computer Vision Traffic Sensor for Fixed and Pan-Tilt-Zoom Cameras</i> Clemson University, Clemson, South Carolina	138
141 <i>Reducing Fatigue in Wind-Excited Traffic Signal Support Structures Using Smart Damping Technologies</i> University of Connecticut, Storrs, Connecticut	139
142 <i>A Shape Memory Polymer-Based Self-Healing Sealant for Expansion Joints</i> Louisiana State University, Baton Rouge, Louisiana	140
143 <i>The Guayule Plant: A Renewable, Domestic Source of Binder Materials for Flexible Pavement Mixtures</i> Missouri University of Science & Technology, Rolla, Missouri	141
144 <i>An Acoustic Emission-Based Test to Determine Asphalt Binder and Mixture Embrittlement Temperature</i> University of Illinois at Urbana-Champaign, Illinois	142
145 <i>Extraction of Layer Properties from Intelligent Compaction Data</i> Colorado School of Mines, Golden, Colorado	143
146 <i>Advanced Methods for Mobile Retroreflectivity Measurement on Pavement Marking</i> Leetronvision, Concord, New Hampshire	144
147 <i>Shape Memory Alloy Enhanced Smart Bridge Expansion Joints</i> Rice University, Houston, Texas Georgia Institute of Technology, Atlanta, Georgia	145
148 <i>Cleaning Device to Remove Debris and Chemicals for Crack/Joint Sealing</i> University of Nebraska, Lincoln, Nebraska	146
149 <i>Use of Energy-Absorbing Breakaway Posts for W-Beam Guardrails in Frozen Soil Conditions</i> Safety by Design Company, Lincoln, Nebraska	147
150 <i>Automated Laser Spectrographic Pattern Matching for Aggregate Identification</i> Chesner Engineering, P.C., Long Beach, New York	148
151 <i>Development of a Simple Test to Determine the Low Temperature Strength of Asphalt Mixtures and Binders</i> University of Minnesota, Minneapolis, Minnesota	149
152 <i>Bridge Cable Inspection with Long-Range Ultrasound</i> WavesinSolids LLC, State College, Pennsylvania	150
153 <i>Bridge Retrofit Laser System</i> Fuchs Consulting, Inc., Leesburg, Virginia	151

Project	Page
154 <i>An Innovative Hybrid Sensor for Rapid Assessment of Sulfate Induced Heaving in Stabilized Soils</i> The University of Texas, Arlington, Texas	152
155 <i>Corrosion Resistant, Structurally Reinforced, Thermal Spray Coatings for In-Situ Repair of Load Bearing Structures</i> Stony Brook University, Stony Brook, New York	153
156 <i>Novel Coating Technology for Improving the Corrosion Resistance and Mechanical Properties of Reinforcing Steel in Concrete</i> Southwest Research Institute, San Antonio, Texas	154
157 <i>Development of an Intrinsically Conducting Polymer-Based Low-Cost, Heavy-Duty, and Environmentally Friendly Coating System for Corrosion Protection of Structural Steels</i> Illinois Institute of Technology, Chicago, Illinois	155
158 <i>Using Nonlinear Acoustics to Identify the Stress State of Critical Bridge Components</i> University of Illinois at Chicago, Chicago, Illinois	156
159 <i>Advanced Cleaning Device to Remove Debris and Chemicals for Crack/Joint Sealing</i> Georgia Institute of Technology, Atlanta, Georgia	157
160 <i>Super-Weathering Steel for Infrastructure Applications</i> Northwestern University, Evanston, Illinois	158
161 <i>Tools for Determining Yield Stress of In-Service Gusset Plates</i> Oregon State University, Corvallis, Oregon	159
162 <i>Full-Scale Prototype Testing and Manufacturing and Installation Plans for New Scour-Vortex-Prevention scAUR and VorGAUR Products for a Representative Scour-Critical Bridge</i> Applied University Research (AUR) Inc., Blacksburg, Virginia	160
163 <i>Development of an Asphalt Pavement Raveling Detection Algorithm Using Emerging 3-D Laser Technology and Macrotecture Analysis</i> Georgia Institute of Technology, Atlanta, Georgia	161
164 <i>Laser Spectroscopy for Rapid Profiling of Steel Bridge Coating, Corrosion, and Heavy Metals</i> Chesner Engineering, P.C., Long Beach, New York	162
165 <i>Battery-Less Wireless Weigh-In-Motion Sensor</i> University of Minnesota at Twin Cities, Minneapolis, Minnesota	163
166 <i>Guidelines for the Use of Waste Concrete Fines</i> University of Pittsburgh, Pittsburgh, Pennsylvania University of Washington, Seattle, Washington	164

-
- 167 *Exploratory Analysis of Augmented Reality Visualization for Right-of-Way Excavation Safety* 165
University of Michigan, Ann Arbor, Michigan
- 168 *Automated and Continuous Aggregate Sampling and Laser Targeting System: Prototype Development* 166
Chesner Engineering, P.C., Long Beach, New York
- 169 *An Inexpensive Vision-Based Approach for the Autonomous Detection, Localization, and Quantification of Pavement Defects* 167
University of Southern California, Los Angeles, California
Purdue University, West Lafayette, Indiana
- 170 *Development and Implementation of the Asphalt Embrittlement Analyzer* 168
University of Illinois, Urbana-Champaign, Illinois
Western New England University, Springfield, Massachusetts
- 171 *Producing a Sustainable and Bio-Based Alternative for Petroleum-Based Asphalt* 169
North Carolina A&T State University, Greensboro, North Carolina
- 172 *Bidirectional-Ductile End Diaphragms for Seismic Performance and Substructure Protection* 170
University at Buffalo, Buffalo, New York
- 173 *Graphene Nano-Platelet (GNP) Reinforced Asphalt Mixtures: A Novel Multi-Functional Pavement Material* 171
University of Minnesota, Minneapolis, Minnesota
- 174 *Enhanced Performance Zinc Coating for Steel in Concrete* 172
Tourney Consulting Group, LLC, Kalamazoo, Michigan
- 175 *Rapid Detection of Fatigue Cracking in Steel Anchor Rods Using the Impulse Response Method* 173
Lehigh University, Bethlehem, Pennsylvania
- 176 *Contactless Electrode for Fast Survey of Concrete Reinforcement Corrosion* 174
University of South Florida, Tampa, Florida
- 177 *Automated Turning Movement Counts for Shared Lanes Using Existing Vehicle Detection Infrastructure* 175
University of Wisconsin-Madison, Wisconsin
- 178 *Development of Renewable Polymers for Use in Asphalt Pavements* 176
Iowa State University, Ames, Iowa
- 179 *Development of a Portable Total-Stress Measurement Instrument* 177
University of Missouri, Columbia, Missouri
- 180 *Drained Timber Pile Ground Improvement for Liquefaction Mitigation* 178
Oregon State University, Corvallis, Oregon

Project	Page
181 <i>Development of Small Specimen Geometry for Asphalt Mixture Performance Testing</i> North Carolina State University, Raleigh, North Carolina	179
182 <i>Reducing Stormwater Runoff and Pollutant Loading with Biochar Addition to Highway Greenways</i> University of Delaware, Newark, Delaware	180
183 <i>A Radio Frequency Identification (RFID) Detection System for Assessing Scour Countermeasures and the Stability of Hydraulic Structures</i> University of Tennessee, Knoxville, Tennessee	181
184 <i>Synthetic Household Travel Data Using Consumer and Mobile Phone Data</i> Transport Foundry, Atlanta, Georgia	182
185 <i>CurvePortal for Automated Identification and Extraction of Horizontal Curve Information</i> University of Wisconsin, Madison, Wisconsin	183
186 <i>Development of an Electrical Resistivity Push Probe for Rapid Assessment of Ground Improvement</i> Colorado School of Mines, Golden, Colorado	184
187 <i>A Low-Cost Mobile Proximity Warning System in Highway Work Zones</i> Georgia Institute of Technology, Atlanta, Georgia	185
188 <i>A Class of V-Connectors for Bridge Deck Pier and Pier-Footing Joints Allowing Integrated Design and Seismic Isolation While Enabling Accelerated Bridge Construction</i> ACII, Inc., Irvine, California/Wilmette, Illinois	186
189 <i>A Novel Vision Sensor for Remote Measurement of Bridge Displacement</i> Columbia University, New York City, New York	187
191 <i>Testing of In-Service Bridges Using Automated Ultrasonic Testing Methods</i> Bridge Diagnostics, Inc., Raleigh, North Carolina	188
192 <i>Application of Microbial Facilitated Stabilization for Sustainable Improvement of Expansive Pavement Subgrades</i> Boise State University, Boise, Idaho	189
193 <i>DART Field Validation and Prototype Refinement</i> Rao Research and Consulting, LLC, Champaign, Illinois	190
195 <i>Development of an IDEAL Cracking Test for Asphalt Mix Design, Quality Control, and Quality Assurance</i> Texas A&M Transportation Institute, College Station, Texas	191

Project	Page
197 <i>Hexagonal Boron Nitride Reinforced Multifunctional Concrete for Transportation Infrastructure</i> C-Crete Technologies, LLC, Houston, Texas	192
198 <i>Prototype Development for Obtaining Automated Turning Movement Counts for Shared Lanes</i> University of Wisconsin, Madison, Wisconsin	193
199 <i>Using Medical X-Ray Machines to Determine the Service Life of Concrete</i> Oklahoma State University, Stillwater, Oklahoma	194
200 <i>Rapid Rehabilitation of Highway Slopes Using Seeded Microbial Bio-Cement</i> South Dakota School of Mines and Technology, Rapid City, South Dakota	195
201 <i>Development of a Novel Aerodynamic Solution to Mitigate Large Vibrations in Traffic Signal Structures</i> Iowa State University, Ames, Iowa	196
202 <i>Vertical Impedance Scanner for Concrete Bridge Deck Assessment without Direct Rebar Attachment</i> Brigham Young University, Provo, Utah	197
203 <i>SaferCushion</i> University of Alabama at Birmingham, Birmingham, Alabama	198
204 <i>Bio-Mimetic Antifreeze Polymers: A Novel Biodegradable Deicing Salt Alternative</i> University of Colorado at Boulder, Boulder, Colorado	199
207 <i>MILDGLASS: GFRP Strands for Resilient Mild Prestressed Concrete</i> University of Miami, Coral Gables, Florida Politecnico di Milano, Milano, Italy University of Dundee, Dundee, United Kingdom	200
208 <i>Determining Bridge Deck Chloride Quantities with Ground-Penetrating Radar</i> Penetradar, Niagara Falls, New York	201
212 <i>Development of Non-Gating Terminals</i> University of Alabama at Birmingham, Birmingham, Alabama	202

SECTION 2: Active IDEA Projects

Project	Page
190 <i>Self-De-Icing LED Signals for Railroads and Highway Intersections</i> University of Kansas, Lawrence, Kansas Kansas State University, Manhattan, Kansas	204

Project	Page
196 <i>Smart Installation and Monitoring System for Large Anchor Bolts of Support Structures for Highway Signs, Luminaries, and Traffic Signals</i> Iowa State University, Ames, Iowa	206
205 <i>Bio-Inspired “MRI” of Concrete Bridges Using Waveform-Based Ultrasonic Tomography</i> PowerPolymer, LLC, Wimberley, Texas University of Illinois at Chicago, Chicago, Illinois	209
206 <i>Rule-Based Automated Safety Monitoring System for Work Zone Safety</i> University of Nebraska-Lincoln, Lincoln, Nebraska University of Houston, Houston, Texas	213
209 <i>An Automated System for Pedestrian Facility Data Collection from Aerial Images</i> The University of Southern Mississippi, Hattiesburg, Mississippi	216
210 <i>Material Characteristics of Cu-Based Superelastic Alloys for Applications in Bridge Columns to Improve Seismic Performance</i> University of Southern California, Los Angeles, California	219
211 <i>Reducing Stormwater Runoff and Pollutant Loading with Biochar Addition to Highway Greenways</i> University of Delaware, Newark, Delaware	222
213 <i>Seahive—Sustainable Estuarine and Marine Revetment</i> University of Miami, Coral Gables, Florida	225
214 <i>An Enhanced Network-Level Curve Safety Assessment and Monitoring Using Mobile Devices</i> Georgia Institute of Technology, Atlanta, Georgia	228
215 <i>Achieving Resilient Multi-Span Bridges by Using Buckling-Restrained Braces</i> University at Buffalo, Buffalo, New York	232
216 <i>A Portable Single Lane Traffic Counting Device</i> Leetron Vision, Concord, New Hampshire	235
217 <i>A Real-Time, Proactive Intersection Safety Monitoring and Visualization System Based on Radar Sensor Data</i> University of Louisville, Louisville, Kentucky	238
218 <i>Development of a Fast and Cost-Effective Asphalt Mixture Fatigue Test System</i> Michigan State University, East Lansing, Michigan	241
219 <i>A Novel Durable, Healable, and Conveniently Removable Pavement Marking Material Suitable for Both Permanent and Temporary Marking Uses</i> North Dakota State University, Fargo, North Dakota	245
220 <i>Bridge Deck Sealant Monitor: Thermal Seal Check</i> Fuchs Consulting, Inc., Leesburg, Virginia	248

Project	Page
221 <i>Development of In Situ Cyclic Borehole Shear Soil Test Device</i> Iowa State University, Ames, Iowa	251
222 <i>Mixed Reality Assisted Infrastructure Inspections</i> University of Central Florida, Orlando, Florida	254
223 <i>Fatigue Crack Inspection Using Computer Vision and Augmented Reality</i> University of Kansas, Lawrence, Kansas	258
224 <i>Development of an IDEAL Cracking Test for Asphalt Mix Design, Quality Control, and Quality Assurance</i> Texas A&M Transportation Institute/Texas A&M University, Bryan, Texas	261
225 <i>An Automated System for Large-Scale Intersection Marking Data Collection and Condition Assessment</i> Old Dominion University, Norfolk, Virginia Cleveland State University, Cleveland, Ohio	264
226 <i>A Smart Internet of Things (IoT) Proximity Alert System for Highway Work Zone Safety</i> Georgia Institute of Technology, Atlanta, Georgia	267
227 <i>Adjustable Cross-Frames for the Erection of Steel Girder Bridges</i> University of Notre Dame, Notre Dame, Indiana Genesis Structures, Inc. Kansas City, Missouri	269
228 <i>A Retroreflective Road Lane Marking Tape 1,000x Brighter than Existing Technology</i> Mark O'Neill, LLC, Fort Worth, Texas	271
229 <i>Laboratory Dielectric Measurement System (LDMS) for Asphalt Mixture Bulk Specific Gravity Determination</i> University of New Hampshire, Durham, New Hampshire	274
230 <i>Automated Data and Feature Extraction from Bridge Plans</i> Iowa State University, Ames, Iowa	277
231 <i>AI Analyzer for Revealing Insights of Traffic Crashes</i> University of Nevada at Las Vegas, Las Vegas, Nevada Queensland University of Technology, Brisbane, Queensland, Australia	279
232 <i>Measuring Concrete Permeability With the Chip</i> Oklahoma State University, Stillwater, Oklahoma	281
233 <i>Development of An Innovative Bio-Mediated Self-Healing Concrete Technology</i> Case Western Reserve University, Cleveland, Ohio	283

SECTION 3: NSF/NRC-IDEA Cooperative Projects

Project	Page
1 <i>Control System for Highway Load Effects</i> University of Michigan, Ann Arbor, Michigan	288
2 <i>Pulse-Echo Tomographic Microwave Imaging Systems for Quantitative NDE of Civil Structures and Materials</i> University of California, Santa Barbara, California	289

INTRODUCTION

This annual report presents a summary of progress on investigations conducted as part of the Innovations Deserving Exploratory Analysis (IDEA) program for the National Cooperative Highway Research Program (NCHRP). The Highway IDEA program is jointly funded by the state highway agencies through membership in the American Association of State Highway and Transportation Officials.

Highway IDEA is one of three IDEA programs managed by the Transportation Research Board (TRB) to foster innovation in highway and intermodal surface transportation systems. Highway IDEA nurtures new concepts for technologies, methods, and processes for application to highway systems in broad technical areas such as highway design and construction, materials, operations, and maintenance. The other IDEA programs are:

- Transit IDEA, which focuses on products and results for transit practice in support of the Transit Cooperative Research Program; and
- Rail Safety IDEA, which focuses on innovative technologies to improve railroad safety and operations.

The Highway IDEA program is open to all individuals, including entrepreneurs, small and large businesses, and institutions. The program provides an opportunity to investigate new and unproven concepts or to evaluate novel applications of technologies that have been tried, tested, or used for highway systems practice.

The selection of each IDEA investigation is made by consensus recommendations from the Highway IDEA Project Panel, which comprises national experts in highway and transportation research and practice and whose members are listed at the beginning of this report. A technical expert is selected from outside TRB to serve as a voluntary advisor to mentor each IDEA project. The technical project advisor provides continuing advice and counsel on the IDEA investigation to the investigator and the IDEA program office. To begin the product transfer process from the initiation of each IDEA project, a regional panel of experts is selected to work with the investigator on product development and transfer to highway practice. The products emerging from the Highway IDEA program support a range of innovative developments for highway user services and for advancing highway systems.

Section 1 of this report presents short descriptions of projects completed before the 2021 program year. The products and results from these projects have been applied or are available for further investigation for application to highway practice. The product status is described under each project. Because of limitations on IDEA resources, not all IDEA concepts that prove feasible can be accommodated for follow-up funding by the Highway IDEA program for product transfer. Section 2 presents reports of investigations on projects active or completed during the 2021 program year; several projects in this section are in the initial stages of investigation. Section 3 presents IDEA projects performed under a cost-sharing initiative with the National Science Foundation, which is no longer active.

In selecting new concepts, the IDEA program balances the quest for new products with an understanding of the barriers each product may face for application to practice. Assessing the level of readiness for deployment of IDEA products and results is important in deciding

on follow-up actions that are necessary to transfer the IDEA product to practice. This annual progress report is intended to provide highway practitioners with the background on each IDEA investigation and product in development so that a dialogue on its potential transfer can take place between the investigator and highway practitioners.

The IDEA program welcomes your comments, suggestions, or recommendations on Highway IDEA projects, products, and results presented in this report. Please forward them to the Highway IDEA Program (attention: Dr. Inam Jawed), Transportation Research Board, 500 Fifth St. NW, Washington, D.C. 20001. Email: ijawed@nas.edu.

SECTION 1

COMPLETED IDEA PROJECTS

This section presents brief summaries of Highway IDEA projects completed before the 2021 program year. The products from these projects have been applied or are available for further investigation for application to highway practice.

ON-LINE REAL-TIME MEASUREMENT AND CONTROL OF AGGREGATE GRADATION IN ASPHALT PLANTS

NCHRP-IDEA Project 1

Felix Alba [Tel.: (801) 264-8294, Fax: (801) 264-8293]

Felix ALBA Consultants Inc., Murray, Utah

Mike Worischeck and Steve Madrigal

STAKER Paving and Construction Company, Salt Lake City, Utah

This IDEA project developed and tested a non-contact video imaging and analysis system (Figure 1) for continuous on-line measurement and flow control of aggregate gradation (size distribution) in an asphalt plant.

The system's hardware consists of a lamp and a line-scan video camera installed over feeder belts from each of the cold bins. The software system incorporates the principles of machine vision, image processing, stereology, and mathematical analysis. Raw images of the aggregates falling onto the master belt are gathered by frame grabbers and preprocessed by image processing boards connected to the data bus of a host computer. Additional image-processing and particle-recognition algorithms determine the chord-length distribution of aggregates from video images. The chord-length distribution is then transformed into volumetric (sieve) size gradations. Proportioning factors for the bins are applied to comply with the job mix formula, and belt feeder speeds are adjusted accordingly to deliver a uniform flow of aggregates automatically.

Field experiments at an asphalt plant show that the system can measure coarse aggregate gradation (3/4", 1/2", 3/8") with a reproducibility better than 2 percent and an accuracy (relative to standard sieving) better than 4 percent on each mesh. The system slightly underreported finer particles, which was attributed to agglomeration of particles under humid plant conditions. The problem was satisfactorily resolved using a semi-empirical procedure. The final report is available from the National Technical Information Service (NTIS # PB97-141642).

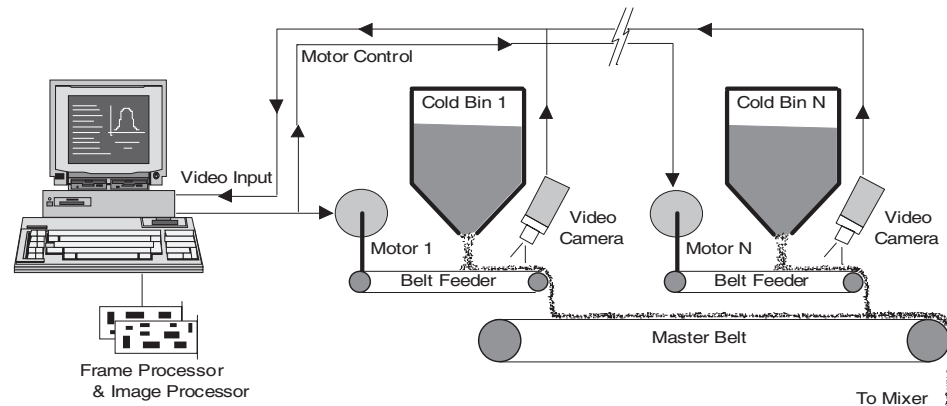

Figure 1

Aggregate gradation control technological concept.

A METHOD FOR MEASURING WATER-STRIPPING RESISTANCE OF ASPHALT/SILICEOUS AGGREGATE MIXTURES

NCHRP-IDEA Project 2

Tinh Nguyen [Tel.: (301) 975-6718, Fax: (301) 990-6891] and Eric Byrd

National Institute of Standards and Technology, Gaithersburg, Maryland

This project developed techniques to assess the stripping resistance of asphalts on siliceous aggregates. The first technique, in situ measurement of the water layer at the asphalt/aggregate interface, is a nondestructive, quantitative technique based on Fourier transform infrared spectroscopy in the multiple internal reflection mode (FTIR-MIR). In this technique, water reaching the asphalt/siliceous aggregate interface is detected by the evanescent wave, which is produced by the total internal reflection of the infrared radiation (Figure 1). This technique provides information on the stripping of asphalt at the molecular level. The second technique relies on the use of a pneumatic pull-off adhesion tester combined with a porous stub that allows water to migrate through the asphalt film to the asphalt/aggregate interface. This reliable and easy to use method provided a rapid laboratory and field test for the water-stripping resistance of asphalt on aggregates.

A number of asphalts from the SHRP Materials Reference Library were used in this investigation. A correlation between bond strength and the amount or thickness of the water layer at the asphalt-aggregate interface was established and formed the basis for a nondestructive test based on FTIR-MIR for determining the water stripping resistance of asphalt-siliceous aggregate mixtures. The concept has proven feasible but the technique is limited to laboratory examination of field samples. The final report is available from the National Technical Information Service (NTIS # PB96-197249).

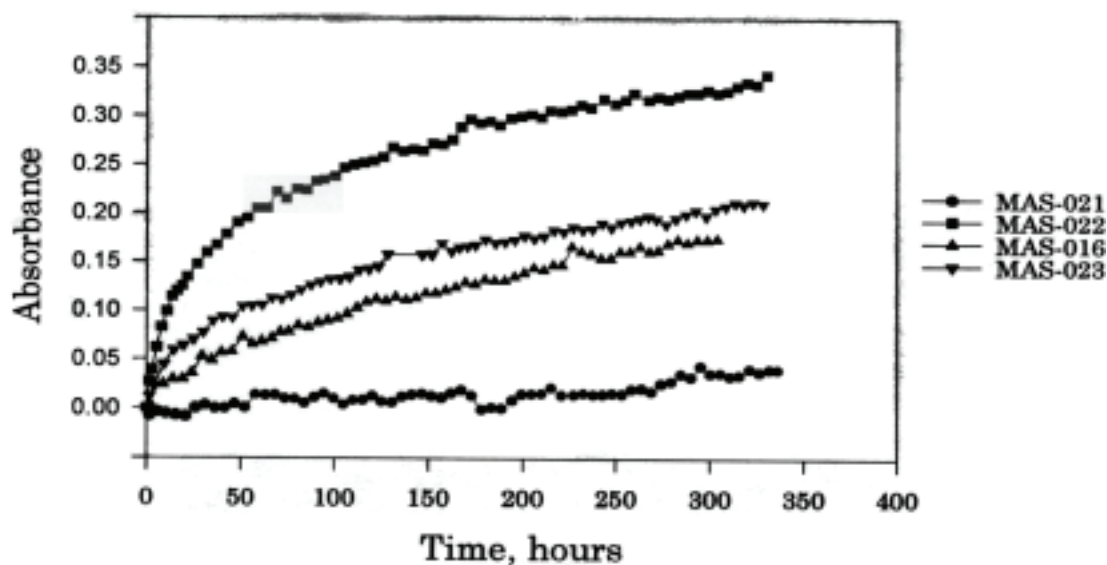

Figure 1

FTIR-MIR intensity of the water layer at the asphalt/siliceous substrate interface for different anti-stripping agents.

GUIDELINES FOR LOW-COST SPRAYED-ZINC GALVANIC ANODE FOR CONTROLLING CORROSION OF REINFORCING STEEL IN MARINE BRIDGE SUBSTRUCTURES

NCHRP-IDEA Project 3

Alberto A. Sagues [Tel.: (813) 974-2275, Fax: (813) 974-3651]
University of South Florida, Tampa, Florida

Rodney G. Powers
Florida Department of Transportation, Gainesville, Florida

The project developed guidelines for using sprayed zinc (as a sacrificial anode system) for protecting reinforcing steel (acting as the cathode) from corrosion in marine bridge structures. Sacrificial cathodic protection by means of sprayed-zinc galvanic anodes is a low-cost alternative to conventional cathodic protection of these substructure components. The surface of the spalled concrete and exposed rebar is abrasively cleaned and sprayed with zinc, using commonly available metallizing equipment. An electrical connection between the zinc and the steel is established directly. Concrete patching is not needed unless required for structural reasons, in which case the zinc is applied over the repaired concrete and a stud is used to connect the steel with the sprayed zinc. The finished cost ranges from \$60 to \$120/m². The method is applicable to a wide variety of structural components.

Laboratory and field experiments demonstrated the feasibility of the proposed approach. Additional performance data were obtained in a large-scale field application (Figure 1). The fieldwork was carried out in collaboration with the Florida DOT during the rehabilitation of the Howard Franklin Bridge on Tampa Bay (State Project 15190-3487). The tests showed adequate probe and steel polarization (typically exceeding the 100-mV depolarization criterion) with moderate current demand (below 1 mA/sq ft) indicating continued cathodic protection of steel reinforcement in the substructure. Based on field results, a manual on the use of sprayed zinc for the protection of marine substructures was prepared. A special two-page IDEA product report, Sacrificial Sprayed-Zinc Galvanic Anode System for Corrosion Protection of Reinforced Concrete in Marine Substructures, was released in June 1995. The final report is available from the National Technical Information Service (NTIS # PB97-141766).



Figure 1

Field installation, Bahia Honda Bridge, Florida Keys.

EXPLORING THE FEASIBILITY OF REPLACING LATEX WITH ASPHALT EMULSION FOR USE IN BRIDGE DECK OVERLAYS

NCHRP-IDEA Project 4

Jan Olek, Menashi D. Cohen [Tel.: (317) 494-5018, Fax: (317) 496-1364]
and Sidney Diamond, Purdue University, West Lafayette, Indiana

This project explored the feasibility of using asphalt emulsion as a low-cost replacement for latex in portland cement concrete for highway applications. Research results showed that addition of emulsion reduced the workability and compressive and flexural strengths of concrete as compared with conventional concrete. The addition of emulsion also increased the amount of entrained air in concrete, which partly accounted for the strength reduction. The asphalt-modified concrete, however, showed excellent freeze-thaw durability (Figure 1). Moist curing appeared to have a better effect on strength development than air curing. Tests also showed that using pozzolanic materials (fly ash or silica fume) in combination with asphalt emulsion significantly reduced the chloride permeability of mortars.

Additional research and field evaluation are needed for the implementation of this product for highway applications. The final report is available from the National Technical Information Service (NTIS # PB95-267704).

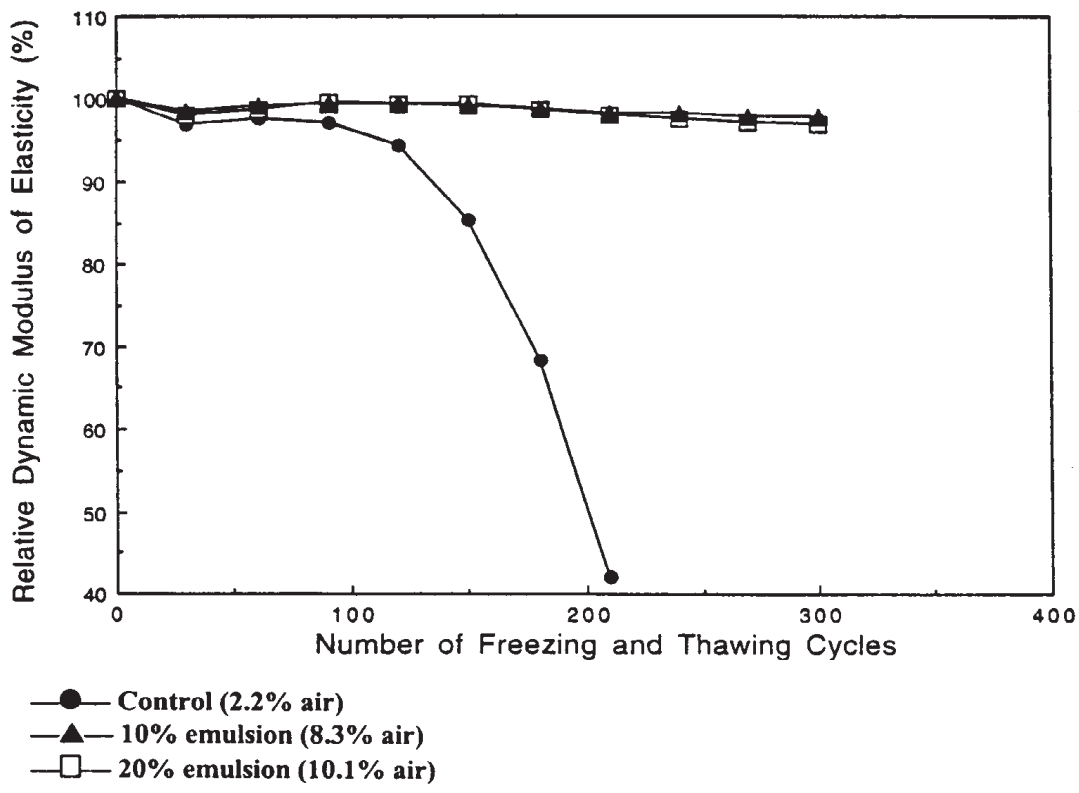

Figure 1

Freezing and thawing test results for plain and asphalt emulsion-modified concrete.

MAGNETIC RESONANCE FOR IN SITU DETERMINATION OF ASPHALT AGING AND MOISTURE CONTENT

NCHRP-IDEA Project 5

J. Derwin King [Tel.: (210) 684-5111, Fax: (210) 647-4325] and Qing Wen Ni
Southwest Research Institute, San Antonio, Texas

This project developed and tested a magnetic resonance-based system for in-motion inspection of asphalt for rapid determination of pavement aging, moisture content, and the condition of asphalt concrete roadways.

A set of asphalt samples from the SHRP Reference Materials Library was used, representing a wide variation in properties that affect asphalt aging. The results showed good correlation of the nuclear magnetic resonance (NMR) data with the viscosity parameters and with aging induced by loss of volatiles and by accelerated oxidation. Electron proton resonance (EPR) studies provided additional information and correlations. EPR studies of neat asphalts showed typical hydrocarbon response from all samples plus a large multipeak vanadium spectrum from some samples. This EPR vanadium signal provides a basis for correction of the NMR data to make the pavement inspection independent of the types of asphalts and aggregates.

The combination of NMR and EPR techniques was shown to be an effective tool for assessing asphalt condition in pavements. The two resonance systems can use the same magnet and be easily integrated to work in tandem to determine asphalt condition. The system can be mounted on a small trailer for mobile in situ inspection. A recommended field design configuration is shown in Figure 1. Extensive field verification of the system is required for the IDEA product transfer. The final report is available from the National Technical Information Service (NTIS # PB95-267688).

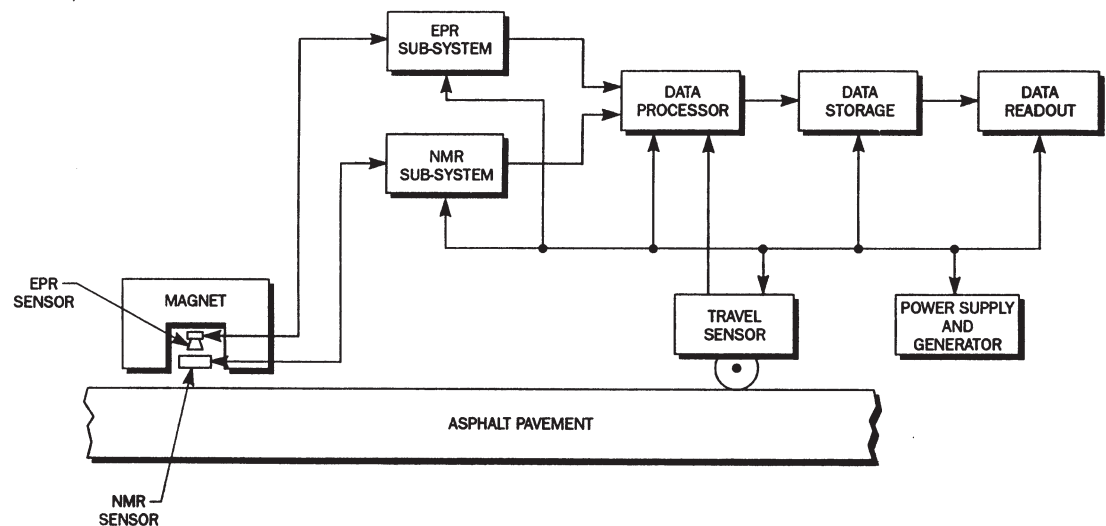

Figure 1

MR system for in situ asphalt inspection.

EXCOGITATED COMPOSITE MULTIFUNCTIONAL LAYER FOR PAVEMENT SYSTEMS

NCHRP-IDEA Project 6

Barry J. Dempsey [Tel.: (217) 333-3963, Fax: (217) 333-4464]

University of Illinois, Urbana-Champaign, Illinois

The project evaluated a concept of a three-dimensional composite layer design for pavement construction for improved performance and service life. The excoGITated composite multifunctional (ECM) layer (Figure 1) will satisfy multiple functions in the pavement system by providing for subbase layer-subgrade separation, subbase shear strength, subbase tensile strength, drainage, and protection of the subgrade from surface infiltration.

The work involved material selection and design and fabrication of the composite layer. A number of synthetic and natural materials were evaluated and several performance-related parameters of the layer were measured. The layer strength was increased significantly by changing the polymer blend in the polyethylene structure and by utilizing a stiffer geotextile. The load-deflection relationship and shear stress for this new layer also showed improvements.

The composite layer was evaluated and compared in large-scale laboratory tests. A test cell, 6 ft by 6 ft by 40 in., was constructed with an overhead frame for mounting a hydraulic ram to perform dynamic testing of the composite layer. Load deformation tests showed that the composite layer performed far better than the geotextile and geogrid sections and sections with no separation layer. The large-scale laboratory tests were followed by a limited field test of the composite layer with satisfactory performance results.

The composite layer now needs to be tested in a full-scale field setting. The ECM layer can be shipped to the construction site in rolls and can be easily placed by roll-out procedures similar to those used for geotextiles.

The final report is available from the National Technical Information Service (NTIS # PB96-154414).

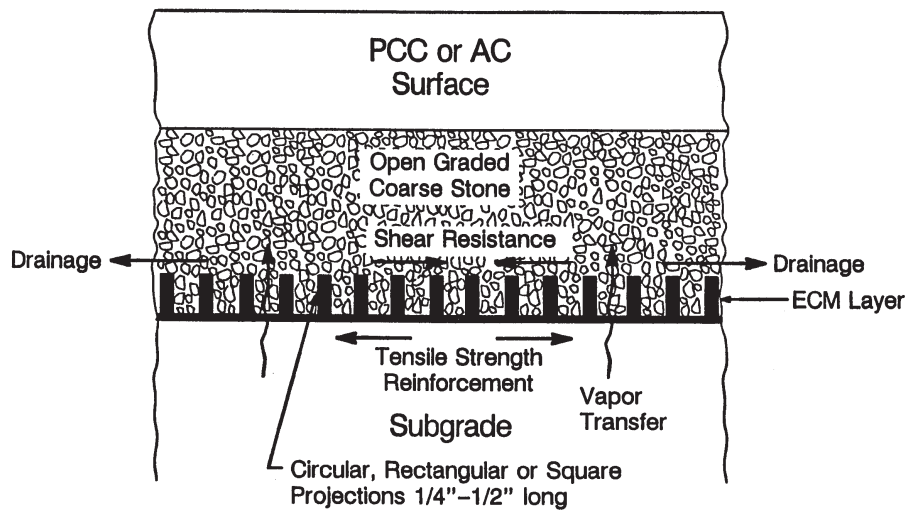

Figure 1

ECM layer concept and functions.

STRATEGY FOR COATING STRUCTURAL STEEL WITHOUT STRINGENT BLASTING REGULATIONS

NCHRP-IDEA Project 7

Simon Boocock [Tel.: (412) 687-1113, Fax: (412) 697-1153]

Steel Structures Painting Council, Pittsburgh, Pennsylvania

The project developed and evaluated an environmentally safe technique for applying durable protective paint coating on structural steel without the need for blast cleaning. The concept is illustrated in Figure 1.

The process employed new high penetration primers with low- or non-organic volatiles. The paint application technology involved embedding collapsible glass microspheres in the primer, which were then broken to interlock the primer with the topcoat. Fracturing the spheres provides a surface profile that "locks in" the topcoat and ensures a strong bond between the primer and the topcoat. Laboratory tests showed that thermal spray-coating systems employing nonvolatile organic compound penetrating sealers loaded with glass microspheres are a viable option for overcoating aged alkyd paints. The addition of glass microspheres to the penetrating primer, however, had no significant effect on the performance of the thermal spray-coating systems.

Microscopic examination of the embedded broken microspheres indicated the potential for enhanced adhesion between the primer and the thermal spray topcoat. The liquid-applied topcoat was also found to be a viable option for overcoating aged alkyd systems.

A series of factorially designed laboratory tests were performed in accordance with standard procedures to determine the effectiveness of the coating system regarding adhesion, impact resistance, and corrosion protection. The results were satisfactory but not significantly superior to the current practice.

The implementation of this new painting process on highway steel bridge structures will require extensive testing in collaboration with state highway agencies. The final report is available from the National Technical Information Service (NTIS # PB96-147996).

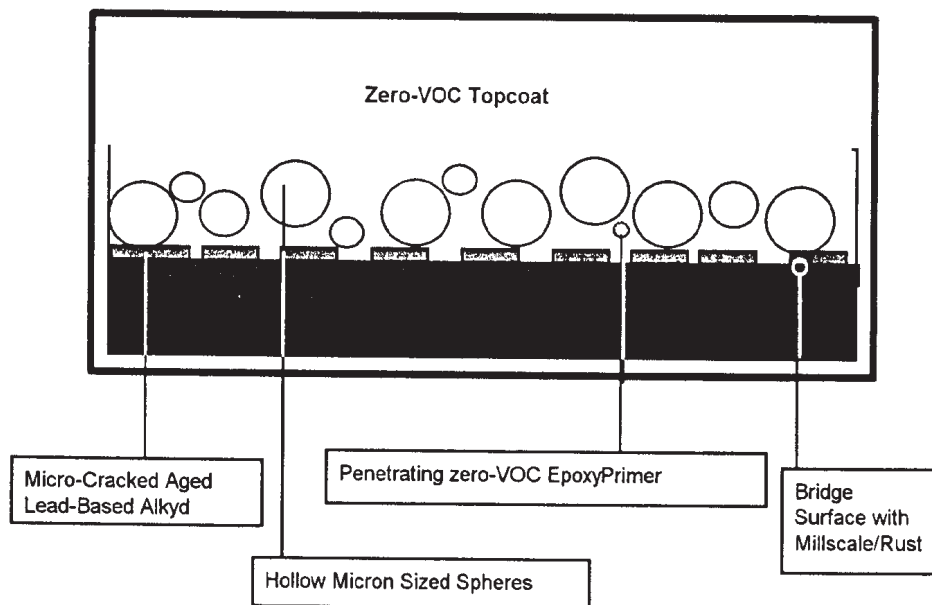

Figure 1

Product applied to bridge use.

CONSERVATION TRAFFIC CONTROL LOAD SWITCH

NCHRP-IDEA Project 8

Gregory A. Filbrun [Tel.: (614) 895-1212, Fax: (614) 895-1213], Paul Wiese, and Greg Winthrow, CLS Incorporated, Westerville, Ohio

The project developed and tested a new microprocessor-based switch system (Conservation Traffic Control Load Switch), which significantly enhances the service life of traffic lamps by reducing the initial current surge in the filament coil. The conservation load switch system mitigates early lamp failure by increasing the voltage to the lamp over an 80-msec ramp-up period and then regulating it at a preset level somewhat below the standard line voltage. The prototype switch system was shown to function satisfactorily in the traffic control unit (signal cabinet). The system uses much less (about 30 percent less) electrical energy to operate the lamp and can be easily retrofitted into existing applicable signal cabinets. It uses the same connector, housing, and mechanical packaging as the standard National Electrical Manufacturers Association (NEMA) Model 170 and Model 200 traffic control load switch units. It can potentially meet all NEMA and Institute of Transportation Engineers (ITE) specifications. The switching system can be installed within a minute in any unmodified signal cabinet (Figure 1).

Operational tests and field evaluations of the switch system were performed. Over 100 units were assembled and sent to a number of state highway agencies for testing. The feedback from highway agencies confirmed the laboratory test results. A continuation project was awarded (NCHRP-IDEA #26) to perform additional field operational tests of the switch system in collaboration with state highway agencies and to develop product transfer and marketing strategies.

A special two-page IDEA product report, Microprocessor-Based Lamp Switch System Quadruples Traffic Lamp Life and Prevents Early Lamp Burn-out, was released in September 1995. The final report is available from the National Technical Information Service (NTIS # PB97-143838).



Figure 1

Installation of conservation load switch in standard cabinet.

CORROSION-RESISTANT STEEL REINFORCING BARS

NCHRP-IDEA Project 9

David Darwin [Tel.: (913) 864-3826, Fax: (913) 864-3199], Carl E. Locke, Jr.,
Matthew R. Senecal, Jeffrey L. Smith, and Shawn M. Schwensen
University of Kansas, Lawrence, Kansas

The project evaluated the corrosion resistance and mechanical properties of steel rebars produced by new microalloying and rolling procedures that exhibit superior corrosion resistance properties. The bars possess a lower carbon content than is usual in U.S. practice and contain copper, chromium, and phosphorus as additional alloying elements. The phosphorus content exceeds that allowed in ASTM specifications. The bars are quenched and tempered immediately after the rolling operation.

Test results (corrosion potential and time-to-corrosion) showed that microalloying decreased the corrosion rate by one-half compared with conventional steel (Figure 1). Quenching and tempering heat treatment in conjunction with microalloying further enhanced the corrosion resistance of steel. The apparent corrosion-resisting mechanisms involve the reduction of microfractures in the surface from the rolling operation due to the quenching and tempering process and the formation of a corrosion-retarding layer of copper chloride-copper hydroxide and iron-chromium oxide at the steel surface. The latter is a poor conductor and thus reduces the corrosion rate. Quenching and tempering had a beneficial effect on the mechanical properties of the steel. Both the yield and tensile strengths were improved. The test results also showed that a phosphorus content in excess of that allowed under current ASTM requirements did not cause the corrosion-resistant steel to be brittle. The new steel also performed well when used in conjunction with epoxy coating.

Extensive field validation tests are required to transfer project results to practice. The final report is available from the National Technical Information Service (NTIS # PB96-147988).

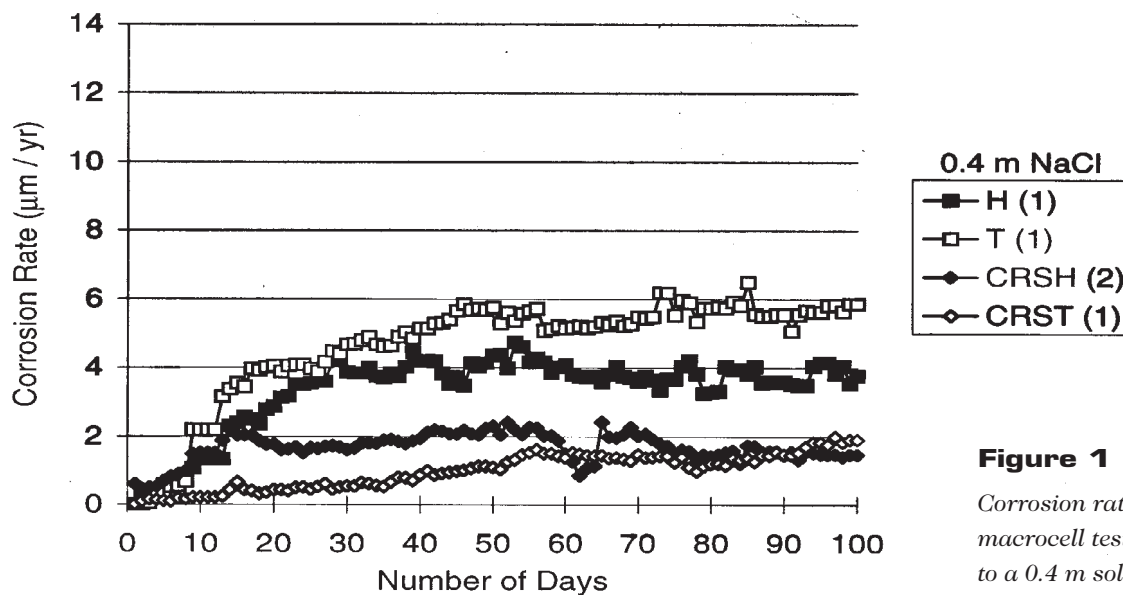

Figure 1

Corrosion rate versus time for macrocell test specimens subjected to a 0.4 m solution of NaCl.

METALLIC COATING FOR CORROSION PROTECTION OF STEEL REBARS

NCHRP-IDEA Project 10

Angel Sanjurjo [Tel.: (415) 859-5215, Fax: (415) 859-2111], Kai Lau, David Lowe,
Palitha Jayaweera, and Gopala Krishnan
SRI International, Menlo Park, California

The project was a follow-up investigation from a previous SHRP-IDEA project in which a corrosion-resistant Si-Ti coating on steel rebars was produced using the fluidized bed technology. The current project was intended to scale up the process to coat rebars up to 3 ft long, as well as to evaluate the coated rebars for corrosion resistance, structural integrity, flexibility, and mechanical properties.

A bench-scale reactor system was designed for coating 3-ft-long steel rebars. The scale-up reactor system appears feasible but may not be adaptable for commercial scale use. The researchers, however, discovered that a strong and coherent coating could be produced simply by spray painting the Si-Ti mixture (along with a flux) followed by a low-heat treatment at about 600°C (Figure 1). This process appears more practical for scaling up for commercial use than the more complex fluidized bed technology.

Because the paint-and-heat or sprayed coatings are not sacrificial, they will provide much superior corrosion protection for a long time. Corrosion tests showed that these coatings reduced the corrosion rate of steel rebars in chloride environments by over one order of magnitude. The preliminary projected cost for the coating appears similar to that of polymer coatings.

The final report is available from the National Technical Information Service (NTIS # PB96-148002).

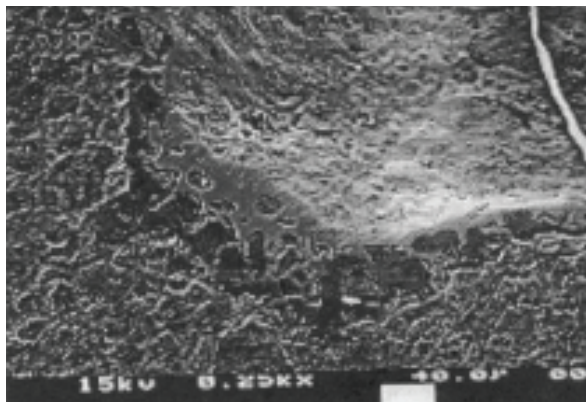

Figure 1

Scanning electron micrograph of coating prepared by paint-and-heat metallization.

REHABILITATION OF STEEL BRIDGES THROUGH THE APPLICATION OF ADVANCED COMPOSITE MATERIALS

NCHRP-IDEA Project 11

Dennis R. Mertz [Tel.: (302) 831-2735, Fax: (302) 831-3640]

University of Delaware, Newark, Delaware

This project evaluated the feasibility of using advanced composite materials for rehabilitation of steel highway bridges as an alternative to conventional repair methods. Stage 1 work performed modeling, fabricating, and testing of two flange repair schemes and proved the feasibility of the concept. Service-load testing on the repair schemes verified that the composite plates increased the stiffness of a section. A finite element model was applied to determine the desired geometry of the composite plate. Rehabilitation schemes were developed and tested for a variety of field geometries. Figure 1 shows various rehabilitation concepts. Test results showed good agreement with model prediction for stiffness enhancement. Increases in girder flexural modules of 20 to 30 percent were found to be attainable, which corresponds to the level of losses expected to be of concern in deficient bridge girders. Sandblasting the steel surface and using a saline pretreatment resulted in best durability for most adhesives. Results also show accelerated bonding through induction heating to be a viable rehabilitation technique in the field. Work in Stage 2 involved additional service load testing of fabricated scale beams, adhesive durability testing, and large scale testing of composite repair of both virgin and corroded steel beams. The results show improved strength and fatigue life of steel components by composite materials. A concern is bond failure, which occurred frequently in small tests. This failure, however, did not occur in large girder tests. Field validation of the technique is required for product transfer to practice. The final report is available from the National Technical Information Service (NTIS # PB97-141964).

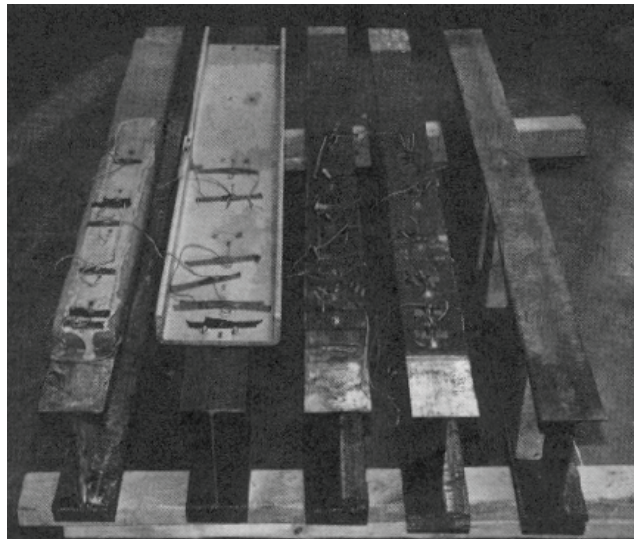

Figure 1

Basic rehabilitation geometries.

ADVANCED TESTING OF AN AUTOMATIC NONDESTRUCTIVE EVALUATION SYSTEM FOR HIGHWAY PAVEMENT SURFACE CONDITION ASSESSMENT

NCHRP-IDEA Project 12

Sidney Guralnick [Tel.: (312) 567-3549, Fax: (312) 567-3634] and Eric S. Suen
Illinois Institute of Technology, Chicago, Illinois

The project refined and field-tested a prototype nondestructive evaluation system previously developed in an FHWA-sponsored project. The system utilizes the Shadow Moiré interferometry method and measures both vertical surface displacement and changes in slope of surface distress. The IDEA research focused on improving the Shadow Moiré inspection technology and completing a comprehensive user-friendly software package to assess road surface distress. Improvements involved an increase of maximum vehicle acquisition speed of 22 percent, new light emitters with special horizontal condensers to improve interference fringe pattern contrast, lightweight grating, as opposed to two smaller gratings for greater road coverage, and a more accurate distance measuring system. Refinements in post-processing included rewriting C-based image analysis algorithms so that they run under the Pentium personal computer (PC) processor rather than slow video processors. Improvements in image digitization were also realized, such as improved image data integrity and large increases in throughput, allowing for faster post-processing of videotape images.

The prototype road inspection vehicle (Figure 1) was an enclosed uni-axle trailer and was capable of acquiring road surface distress information at velocities up to about 55 mph, allowing users to categorize, rate, and determine roadway locations of all out-of-plane surface deformations along a particular roadway. The cost of the road inspection system is estimated to be about \$60,000.

Ford Motor Company donated a full-size field vehicle to replace the trailer system for performing field tests. The system is ready for field validation under operational conditions.

A special two-page IDEA product report, Surface Condition Assessment and Profiler System for Pavements Using Shadow Moiré Interferometry, was released in June 1995. The final report is available from the National Technical Information Service (NTIS # PB97-151617).



Figure 1

Automated road inspection vehicle during field testing.

NEW ADDITIVE FOR IMPROVED DURABILITY OF CONCRETE

NCHRP-IDEA Project 13

Jack E. Stephens [Tel.: (203) 486-4014, Fax: (203) 486-2298] and James Mahoney
University of Connecticut, Storrs, Connecticut

James R. Humphrey
Todd Chemical, Cheshire, Connecticut

The project evaluated a class of organic compounds (diammonium salts of alkenyl dicarboxylic acids) as additives for concrete that may improve the concrete's durability against freezing and thawing and reinforcement corrosion. The material also reduces heavy metal leachate, potentially making environmentally acceptable the use of incinerator ash (both bottom and fly ash) in concrete.

Freeze-thaw, compression, and indirect tension tests were performed to determine the effect of additives on concrete properties. Porosity and permeability measurements also were done to determine additives' effectiveness in preventing chloride salt solution from accessing the steel. Results showed a rather adverse effect of admixtures on concrete workability and strength. Also, the permeability was not significantly improved. However, the concrete showed excellent freeze-thaw resistance (Figure 1). Furthermore, leaching tests showed that the admixtures significantly decreased the leaching of lead from the concrete. The admixtures have potential to be effective air-entraining agents for concrete for improved freeze-thaw durability. The final report is available from the National Technical Information Service (NTIS # PB96-147970).

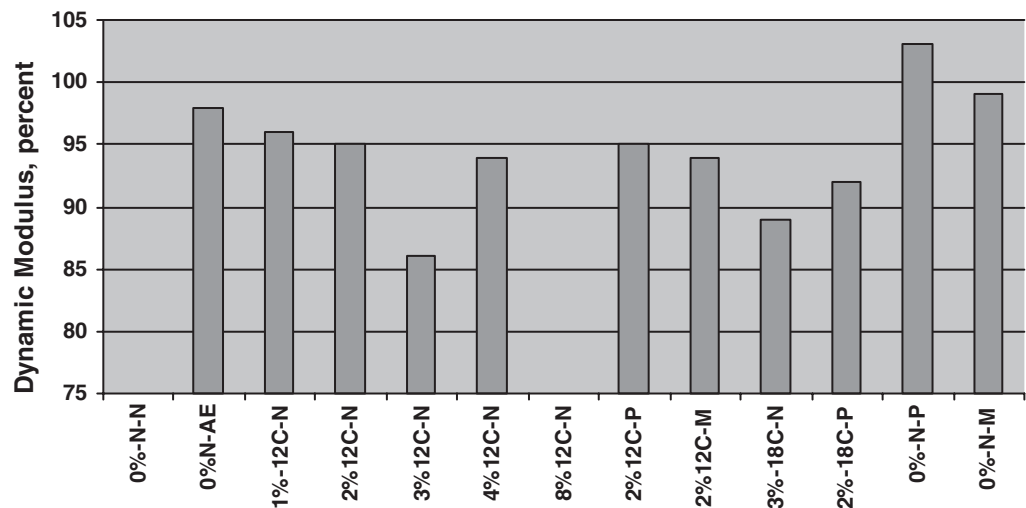

Figure 1

Freezing and thawing test results for concrete specimens containing organic additives.

UNREINFORCED, CENTRALLY PRESTRESSED CONCRETE COLUMNS AND PILES

NCHRP-IDEA Project 14

D.V. Reddy [Tel.: (407) 367-3443, Fax: (407) 367-3885]
Florida Atlantic University, Boca Raton, Florida

Paul F. Csagoly
Clearwater, Florida

This project tested the concept of centrally prestressed, unreinforced concrete (CPUC) columns and piles for application to highway structural systems. In the CPUC column, the innate incompatibility between concrete and steel is eliminated by removal of the latter; but flexural resistance and ductility are restored by the application of a centrally located prestressing tendon or closely spaced strands. This concentration of steel results in a significant increase in concrete cover for better corrosion protection without loss of strength.

Specimens of CPUC columns and piles were evaluated to assess the feasibility and practicality of the concept. Test results showed that the prestressed column provided a substantial increase in effective cross section to withstand both axial and shear loading compared to conventional reinforced concrete columns. Figure 1 illustrates the second innovation, labeled as an extended performance flexural (EPF) device. The EPF device is not a shock isolator, but a completely structural device intended for connecting pier columns to either the superstructure or the substructure, or both, and transmitting considerable moments while permitting large rotations. It sustained several cycles of rotations up to ± 10 percent without damage. Analytical application of the EPF device to a bridge structure indicates close to one order of magnitude increase in the fundamental period of vibration and a decrease of 65 percent in the equivalent static lateral force used in earthquake design. Large-scale field tests on actual highway structures are needed for implementation of this IDEA product. The final report is available from the National Technical Information Service (NTIS # PB97-160816).

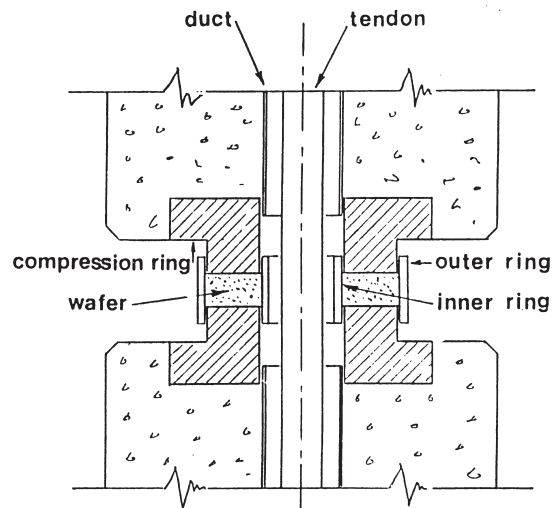

Figure 1

EPF device schematic.

PORTABLE LASER ROAD CREW WARNING SYSTEM

NCHRP-IDEA Project 15

Keith Higgenbotham [Tel.: (703) 367-6838, Fax: (703) 367-2370] and Rudolph Gammarino
Lockheed Martin Corporation, Manassas, Virginia

The project applied a laser technology to develop a portable warning system to improve safety for highway workers (Figure 1). The system consists of a battery-powered master laser transmitter mounted on a traffic cone, one or more laser receiver-transmitters also mounted on traffic cones, and a worker-notification warning system. A pulsed laser beam from the master laser transmitter is directed toward the laser receiver-transmitter located at the end of taper. The beam is detected by the receiver at that point. The detection event triggers the laser that is co-located with the receiver, and it transmits laser pulses toward a second receiver located at the end of the work zone. The retransmitted beam is received by the final detector at the end of the work zone. If the first beam or the retransmitted beam is interrupted by an errant vehicle at any point, the lack of a laser signal at the final receiver causes an electrical signal to be generated that activates an alarm system, notifying workers to take evasive action. In this way, the laser beam acts as an electro-optical barrier along the taper and the work zone.

The system configuration can be modified to suit the size and nature of highway maintenance activity. A field demonstration was carried out at the contractor's facility in California with satisfactory performance. The final report is available from the National Technical Information Service (NTIS # PB97-143861).

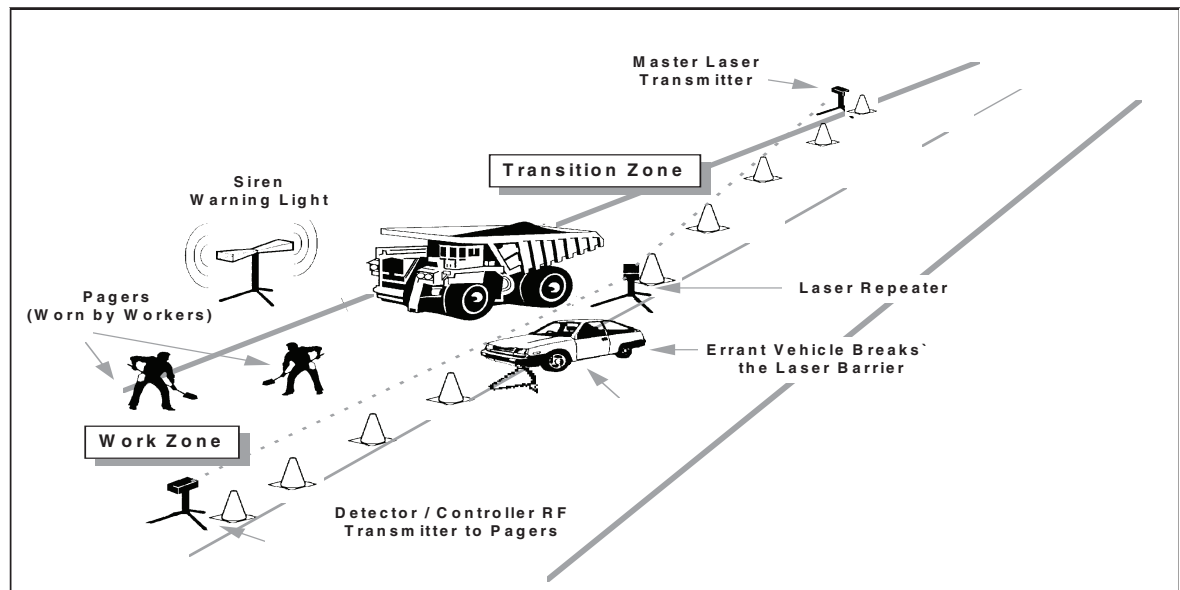

Figure 1

Road crew portable laser warning system.

LASER REMOVAL OF PAINT ON PAVEMENT

NCHRP-IDEA Project 16

Hans Pew [Tel.: (801) 225-0930, Fax: (801) 221-1121] and James Thorne
MOXTEK, Incorporated, Orem, Utah

The goal of this project was to develop a mobile highway paint removing system based on pulsed laser. The concept was to apply a succession of short, intense laser pulses that create destructive shock waves rather than heating paint to the point where chemical reactions occur. The product's impact will be (a) the elimination of the usual environmental contaminants such as grit, dust, smoke, and chemicals; (b) prevention of damage to pavement during paint removal; and (c) complete removal for compliance with federal codes that require no visible trace of temporary markings on newly constructed roadways. Work in the initial phase of the project established the feasibility of using a laser to remove markings from highway materials. A prototype portable laser was developed for removal of paint from the pavement of highways, parking lots, and airfield runways. The removal was clean, but not fast. Several methods that would possibly speed the removal were defined and investigated. The dominant variables were power density (watts/cm²) and pulse duration. Work then focused on selecting and testing a laser that could be used to demonstrate removal of markings in field conditions. The laser needed to meet certain specifications and still remove a painted stripe as rapidly as possible (hopefully at a rate that is competitive with sandblasting). The requirements included reliability in a highway environment (flash lamps easy to change, realignment not necessary, etc.), optimum pulse energy density, pulse duration and wavelength, and, most important, maximum average power for the size and cost of the laser. Consequently a new more powerful system was designed.

The present system uses a new high-power laser that produces short pulses at 1.06- μ m wavelength and has shown promising results on asphalt and concrete surfaces in laboratory tests. The paint removal efficiency of the laser system also depends on the type of the paint. Epoxy-based paints were removed with better efficiency than other paints. The system was attached to a mobile carriage for field demonstration. Further optimization and field trials are needed in order to establish the effectiveness of the system in the field.

The final report is available from the National Technical Information Service (NTIS # PB2000-104071).

SELF-CONTAINED PORTABLE DEVICE FOR SHRP BINDER TESTING: FIELD QC/QA TESTING WITH THE DUOMORPH

NCHRP-IDEA Project 17

Samuel H. Carpenter [Tel.: (217) 333-4188, Fax: (217) 333-9464]
University of Illinois, Urbana-Champaign, Illinois

The project developed a portable field device (Duomorph) for testing asphalt binder properties that will complement the SHRP (Strategic Highway Research Program) dynamic and bending beam rheometers. Figure 1 shows typical Duomorph assemblies. The research was intended to improve and refine Duomorph technology by using new piezoelectric materials, sensors, improved digital technology, newer electronic equipment, and finite element modeling to make and validate a self-contained portable device for field use at temperatures ranging from -28°C to $+80^{\circ}\text{C}$, the Superpave range of temperature. In Stage 1, a Duomorph testing system (Duomorph Asphalt Rheology Test or DART) was assembled and shakedown tests were performed in the laboratory using SHRP reference asphalt binders. The tests have demonstrated that the DART system is durable and provides data that compare well with standard SHRP equipment. A 2-inch gauge size appears satisfactory for testing. Stage 2 work performed a functional testing system and extensive experimentation to establish operational characteristics at various temperatures as required in SHRP binder specifications. A supplemental award (NCHRP-IDEA Project 41) was made for further refinement of the device and for field testing and demonstration to state highway agencies. The final report is available from the National Technical Information Service (NTIS # PB97-143879).

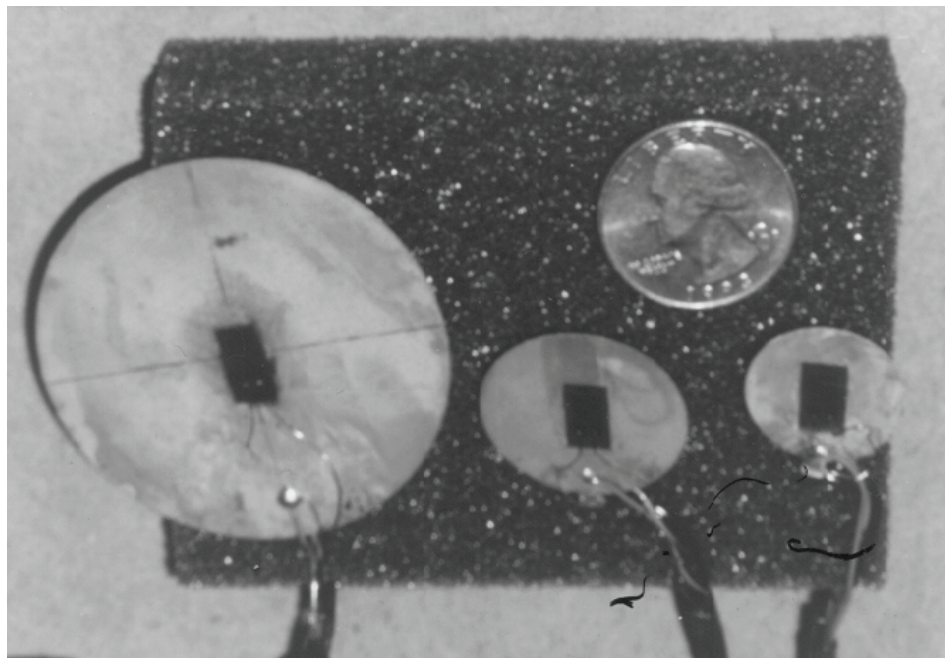

Figure 1

Duomorph assemblies.

NEW PRINCIPLES OF DESIGN FOR CUTTING TOOLS TO REPAIR AND REMOVE PAVEMENTS BASED ON THE EFFECT OF LATERAL PROPAGATION OF CRACKS UNDER CONTACT LOADING

NCHRP-IDEA Project 18

Igor Sveshnikov [Tel.: +7 (044) 263-84-07, Fax: +7 (044) 265-09-95]

POTOK Centre, Kiev, Ukraine

This project developed tool designs for energy-efficient cutting and removal of concrete pavement. The concept takes advantage of the lateral propagation of cracks in concrete produced by using indentors with unconventional asymmetric geometric shapes (Figure 1). The production of lateral cracks in hard rocks facilitates the breaking and removal of material with reduced energy consumption and improved efficiency and productivity. The effectiveness of various indenter configurations was investigated for crack initiation and propagation in rocks, such as limestone, and model materials, such as unreinforced optical glass. Results of theoretical modeling and experimental tests show that cutters with an asymmetric elliptical insert are most effective in producing cracks and breaking the rocks with considerably reduced energy consumption. Based on theoretical and experimental work, the tool designs were developed and prototypes were fabricated and delivered.

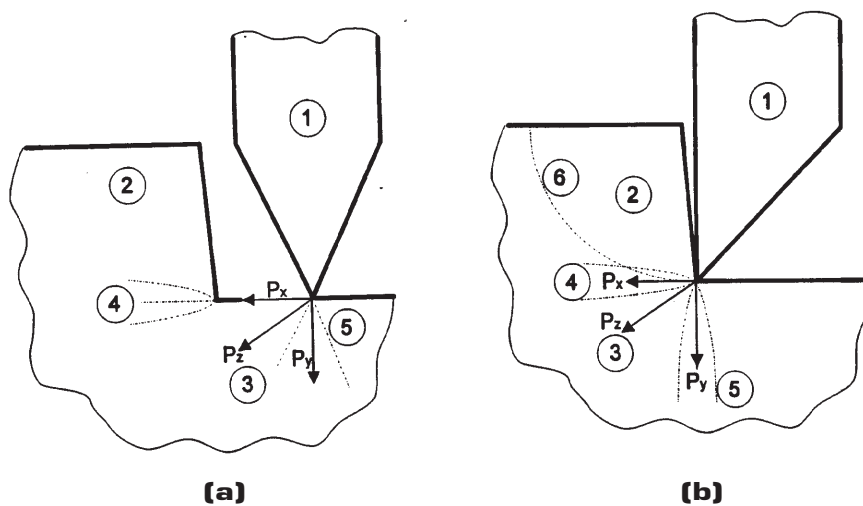

Figure 1

Crack propagation of friable material under contact of (a) indenter of traditional shape and (b) indenter of special shape (1, cutter; 2, rock; 3, element of cutting strength; 4, system of subhorizontal cracks; 5, system of vertical cracks; 6, trajectory of rock mass destruction).

ALUMINUM BRONZE ALLOY FOR CORROSION-RESISTANT REBAR

NCHRP-IDEA Project 19

David Stein [Tel.: (817) 473-1996, Fax: (817) 463-1997]

Man-Tech Development Inc., Mansfield, Texas

This project evaluated aluminum bronze alloy as a possible alternative to steel for corrosion-resistant concrete reinforcement. Rebars from aluminum bronze alloy were fabricated for laboratory and field evaluations. Initial tests showed rather low mechanical properties for alloys as compared to steel. Further work focused on improving the strength and mechanical properties of the alloy by optimizing its composition and fabrication process. The process eliminated the hot rolling operation and entailed direct continuous casting of aluminum bronze to a near net size and shape of rebar followed by cold drawing the bar to finished size and shape. The cold drawing operation increased the strength of aluminum bronze rebars close to that of mild steel rebar, meeting the ASTM specifications (Figure 1). In corrosion tests, the aluminum bronze alloy showed high resistance to seawater corrosion as compared to mild steel and ductile steel (Figure 2). Cost analysis of aluminum bronze rebars showed a cost of \$0.85 per lb as compared to \$1.20 per lb for stainless steel at current metal prices. The final report is available from the National Technical Information Service (NTIS # PB97-141972).

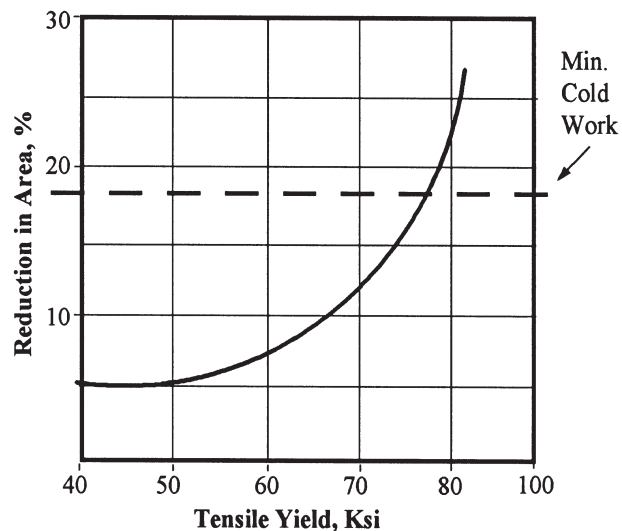

Figure 1

Tensile yield strength of aluminum bronze as a function of strain hardening.

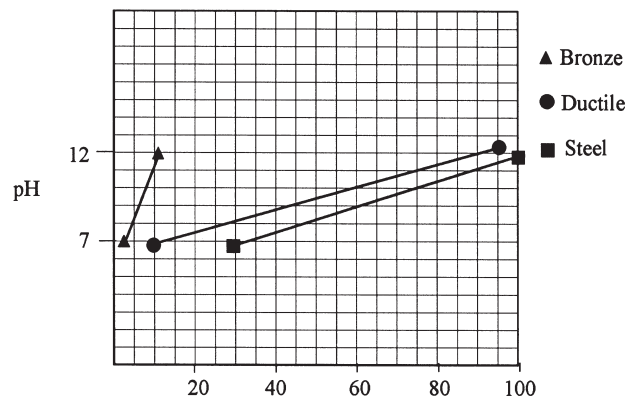

Figure 2

Corrosion rates of three alloys to chloride ion corrosion.

CARBON DIOXIDE (DRY ICE) CLEANING TO REMOVE HIGHWAY ROAD MARKINGS AND STRIPES

NCHRP-IDEA Project 20

Andrew W. Pazahanick [Tel.: (800) 832-4262, Fax: (404) 985-9179]

Tomco Equipment Company, Loganville, Georgia

This project developed and tested an environment-friendly process for pavement paint removal using CO₂ pellets. The system uses either air or an electric motor to propel the dry ice pellets. Dry ice pellets are directed at an accelerated rate from a centrifugal system through a gunlike nozzle attached to a single hose (Figure 1) onto the pavement for cleaning paint markings. The centrifugal system propels dry ice pellets at a significantly higher rate than the pneumatic system.

The pneumatic CO₂ cleaning system showed excellent results on core samples. However, it was impracticable to use a 2-inch nozzle to remove road marks and stripes on highways. In addition, the exit pattern from the centrifugal system needed to be designed for removing various sizes of road markings and stripes. The test results, however, show that the process is especially suitable for cleaning road markings and stripes. The process can, therefore, be used to restore the brilliance and extend the life of markings and stripes by removing a very fine layer from the top of the existing markings and stripes. In addition, it can be used to remove temporary road markings and stripes. The dry ice consumption was about 150 lbs per hour using the pneumatic system. At this rate, if cleaning could be accomplished in one pass, CO₂ cleaning would be cost-effective as compared to burning or grinding markings and stripes.

Further field testing is needed in order to develop a commercially feasible system.

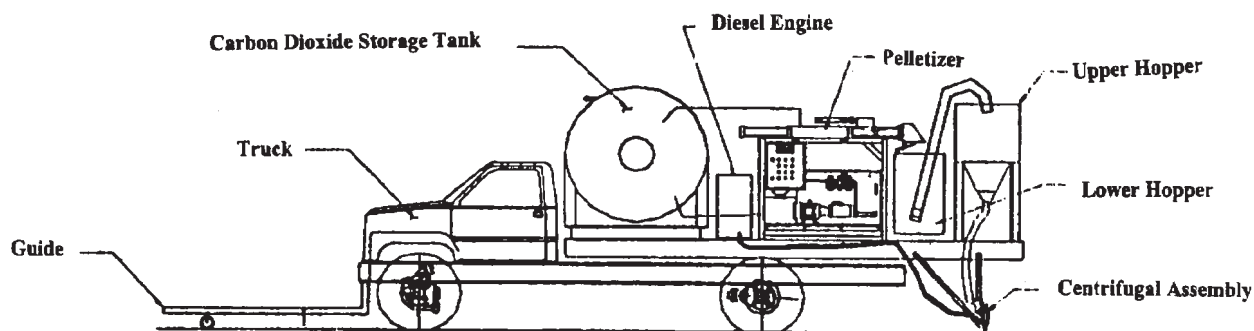

Figure 1

Drawing of proposed centrifugal transport.

DEVELOPMENT OF LED LIGHT SOURCE FOR TRAFFIC CONTROL DEVICES

NCHRP-IDEA Project 21

Mark Finkle [Tel.: (814) 355-4479, Fax: (814) 355-5817]

The Last Resource Inc., Bellefonte, Pennsylvania

This project produced a multi-use, light-emitting device with delineation and warning capabilities based on light-emitting diode (LED) technology (Figure 1). The LEDs have a much longer life span than conventional lamps and require less power to operate. The internal light source can be placed in different types of housings that would allow the device to be used as a delineator, raised pavement marker, or steady-burn/flashing warning light. The result is a device that requires less maintenance and is more flexible in its use. The development of a prototype traffic control device (TCD) involved design and construction of the internal hardware for the LED light source and different types of housing required for the TCD system. Results based on accelerated testing show that the LED light source concept works as expected and produces significant gains over conventional light sources (Figure 2). The system now needs to be tested by state highway agencies.

The commercialization of the IDEA product was explored. Various TCD manufacturers were contacted. Because the light source and power controller are separate modules, that application of the active power management appears more attractive to manufacturers than the complete product. The final report is available from the National Technical Information Service (NTIS # PB97-143846).

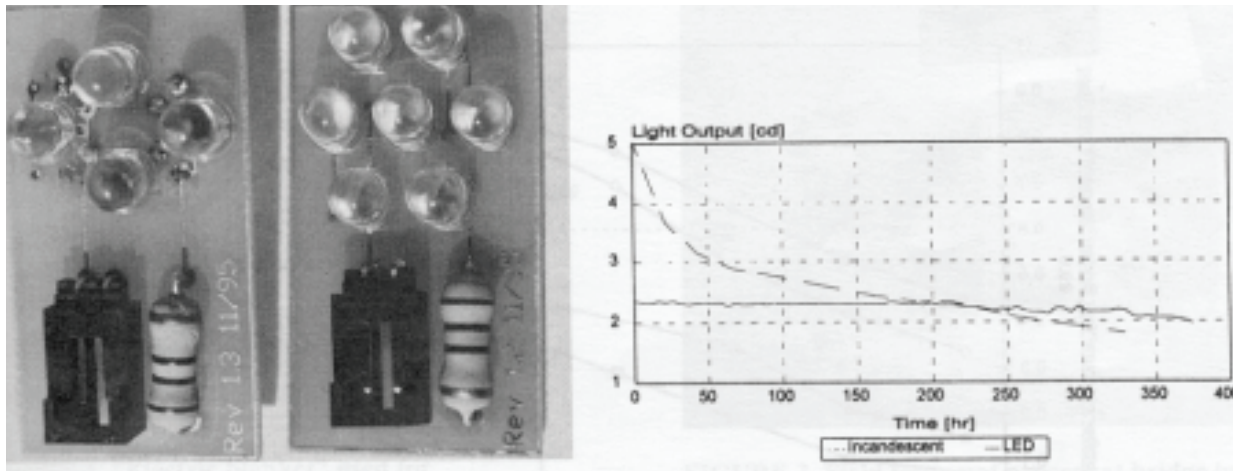

Figure 1

High- and low-intensity LED devices.

Figure 2

Results of endurance testing.

USE OF PHASE CHANGE MATERIALS TO PREVENT OVERNIGHT FREEZING OF BRIDGE DECKS

NCHRP-IDEA Project 22

Ival Salyer [Tel.: (543) 229-2654, Fax: (543) 229-4251]

University of Dayton Research Institute, Dayton, Ohio

This project evaluated a class of polymeric materials (linear crystalline alkyl hydrocarbons) that store and release heat energy as a result of phase change in freezing temperatures for use in concrete to prevent overnight freezing of bridge decks. The phase-change materials were encapsulated in high density polyethylene pellets and either mixed with or installed around concrete to provide heat energy. Modeling verification of the thermal response of bridges and roads under varying climatic conditions and with various phase-change materials and application methods was performed. This was followed by laboratory tests and limited field evaluation to establish material performance and effectiveness in the highway freeze-thaw environment.

The test results show that the addition of phase-change materials to the concrete prevented freezing on the surface (Figure 1). However, the addition of the materials also decreased the conductivity of concrete slabs, which slowed its warming and also adversely affected the performance of phase-change materials. Placing the material at the bottom of the concrete slab delayed the cooling of the slab top surface. It also slowed its warming, which was not desirable. Darkening the top surface had a beneficial effect on the slab surface temperature. The final report is available from the National Technical Information Service (NTIS # PB97-143820).

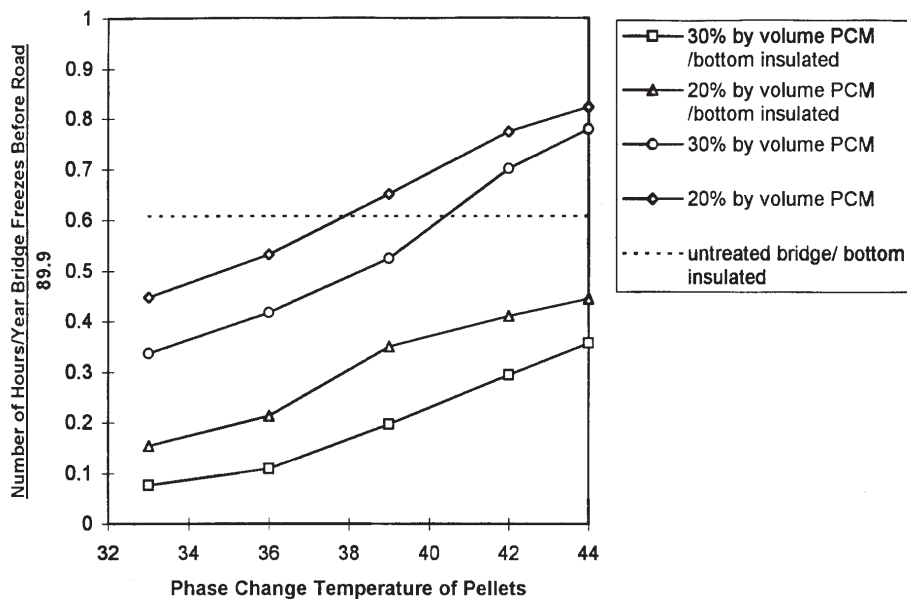

Figure 1

Hazard reduction as affected by phase change temperature for an 8-inch-thick deck with phase-change material pellets in the top half.

LEAD-BASED PAINT REMOVAL FROM STEEL STRUCTURES

NCHRP-IDEA Project 23

Rudolf Keller [Tel.: (412) 325-3260, Fax: (412) 335-8402]

EMEC Consultants, Export, Pennsylvania

This project evaluated an electrochemical cathode debonding process for stripping paint from highway steel structures (Figure 1). The method eliminates airborne paint particles and is a viable alternative to the common abrasive blasting of lead-based paint. In addition, toxic lead components can be collected and recycled. Laboratory tests were carried out to determine concept feasibility and to optimize process parameters. The process effectively debonded and removed paint from steel surfaces in one to two hours using 10-cm x 10-cm electrolytic patches under a constant voltage of 8 to 12 V and a current of 7.5 A or less. A prototype paint removal equipment system was designed for larger-scale testing.

After additional process optimization in the laboratory, small-scale field tests on highway bridges and steel structures were performed to establish the application's feasibility in actual highway structures (Figure 2). The field work showed promising results. Some initial surface preparation may be necessary to initiate the process. A supplemental IDEA award was approved for full-scale field demonstration of the technology on highway bridges in collaboration with the Virginia Department of Transportation (NCHRP-IDEA #38). The final report is available from the National Technical Information Service (NTIS Project PB97-141980).

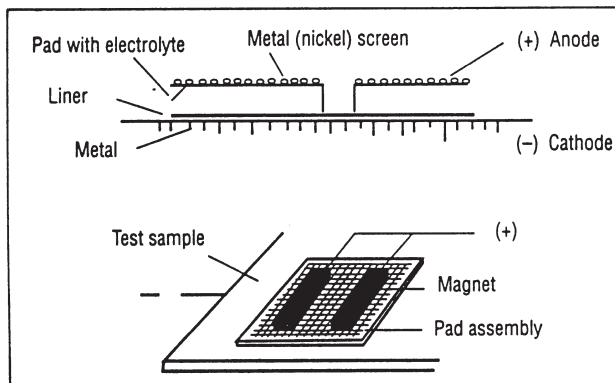

Figure 1

“Electric blanket” used for electrochemically assisted paint removal.

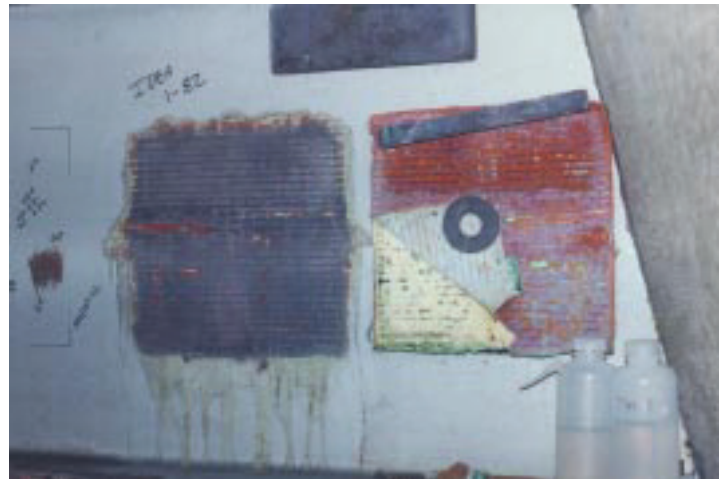

Figure 2

Field testing of process at bridge in Pennsylvania.

FIBER-OPTIC STRAIN SENSOR SYSTEM FOR LONG-TERM MONITORING OF HIGHWAY STRUCTURES

NCHRP-IDEA Project 24

Ken Lou [Tel.: (602) 730-4446, Fax: (602) 893-8643]

Simula Government Products Inc., Phoenix, Arizona

The project investigated the feasibility of a fiber-optic (FO) strain sensor system for long-term monitoring of highway structures. The principle of operation relies upon measuring the time-of-flight of an optical signal's propagation through an optical fiber and then its conversion to mechanical strain. By segmenting an optical fiber string with optical reflectors, the strain of in-line segments can be determined separately. This method enables strain mapping of an entire structure with a finite-element sensor grid and is capable of detecting localized damage, such as cracking and stress corrosion. The monitoring system includes a high-resolution optical time domain reflectometer (OTDR), FO data acquisition (FODAC) software, and FO strain gauge patches (FOSGPs), which allow monitoring of integral strain in large structures (Figure 1). The FOSGPs are flexible sensor patches that can be embedded in or attached to the structure to be monitored.

Tests with steel and composite coupons showed that, using the latest OTDR, the FOSGP sensors achieved a resolution of 0.01 percent strain and could resolve tensile strain in reinforced concrete just before failure due to fracture.

The sensitivity of the FOSGP sensor appears to be limited by the OTDR system. Also, the potential to multiplex patches in-line (to interrogate multiple locations) was limited because of increased attenuation of the FO sensors by the glass-reinforced epoxy carrier material. For the time-delay strain measurements to be practical for structural monitoring, OTDR accuracy must be improved to at least better than 3.0 ps. The smaller 3-m patches may be multiplexed, but would require an OTDR with a resolution of better than 1.0 ps. The sensors appear to be most successful at detecting strain if placed at compression locations on concrete structures. The final report is available from the National Technical Information Service (NTIS # PB98-139074).

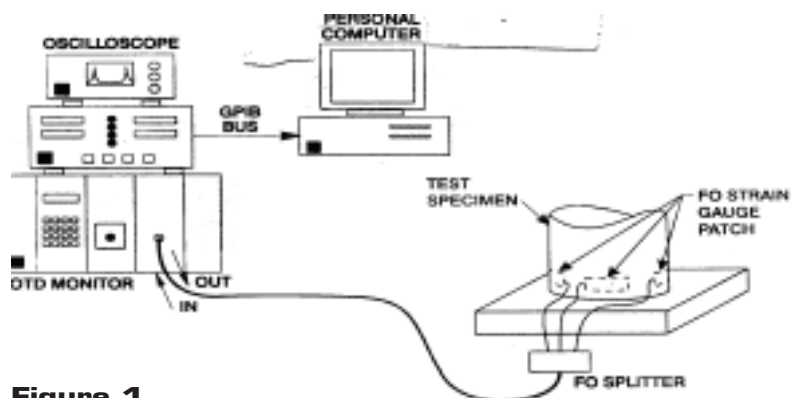

Figure 1

Fiber-optic sensor data acquisition system.

BASALT FIBER COMPOSITE REINFORCEMENT FOR CONCRETE

NCHRP-IDEA Project 25

V.B. Brik [Tel.: (608) 244-1349, Fax: (608) 244-9071]

Research and Technology Inc., Madison, Wisconsin

This project explored the feasibility of using rebars made from braided basalt fiber strands as concrete reinforcement (Figure 1). The material is expected to be a low-cost, high-strength, high-modulus, and corrosion-resistant alternative to steel for concrete reinforcement. The basalt fibers were produced using a process developed in Ukraine. Several types of basalt fibers were procured from Ukraine and evaluated for strength, brittleness, and tensile properties. A continuous basalt fiber, 9 to 15 mm in diameter, was determined to be most suitable for rebar fabrication. The rebars, consisting of about 80 percent to 90 percent fibers and an organic binder, were fabricated and tested for mechanical properties (strength and modulus) and corrosion resistance. Test results established the suitability of basalt composite rebars for use as concrete reinforcement (Table 1).

A supplemental IDEA award for large-scale and field operational testing of basalt rebars as concrete reinforcement was approved (NCHRP-IDEA Project 45). The final report is available from the National Technical Information Service (NTIS # PB97-161335).

Table 1. Mechanical test Data for epoxy-bonded basalt fiber composite specimens.

Specimen No.	Width (mm)	Thickness (mm)	Failure Load (pounds)	Ultimate Strength (psi)	Elastic Modulus (msi)	Poisson's Ratio
1	25.0	3.3	10,340	83,738	4.52	0.128
2	25.0	3.3	10,340	83,738	4.52	0.128
3	24.8	3.1	10,512	37,745	5.40	0.205
4	24.8	3.2	10,040	81,558	4.61	0.210
5	25.0	3.3	10,368	83,952	4.98	0.177



Figure 1

Basalt fiber composite rebars.

CONSERVATION CONTROL LOAD SWITCH OPERATIONAL TESTS

NCHRP-IDEA Project 26

Greg Filbrun [Tel.: (614) 895-1212, Fax: (614) 895-1213]
 CLS Inc., Westerville, Ohio

This is a follow-on project for a previous IDEA project (NCHRP-IDEA Project 8) to perform field operational testing of an improved conservation traffic control load switch system. This microprocessor-controlled switch system extends the life of incandescent traffic lamps by reducing the initial current surge in the filament coil. About 100 units were assembled and provided to highway agencies for evaluation. Based on the users' feedback, the switch housing design was modified. The Institute of Transportation Engineers (ITE) and the National Electrical Manufacturers Association (NEMA) specifications were met and NEMA certification of conformance for the switch system was completed. The device is mechanically compatible with NEMA model 200 cabinets and, with minor housing adjustment, also with 170 signal cabinets.

Figure 1 compares historical and expected lamp maintenance expenditures for a standard three-lamp signal head and a three-lamp signal head using the IDEA product. The product was further evaluated in a pooled-fund study by a number of states. The final report is available through the National Technical Information Service (NTIS # PB97-143853).

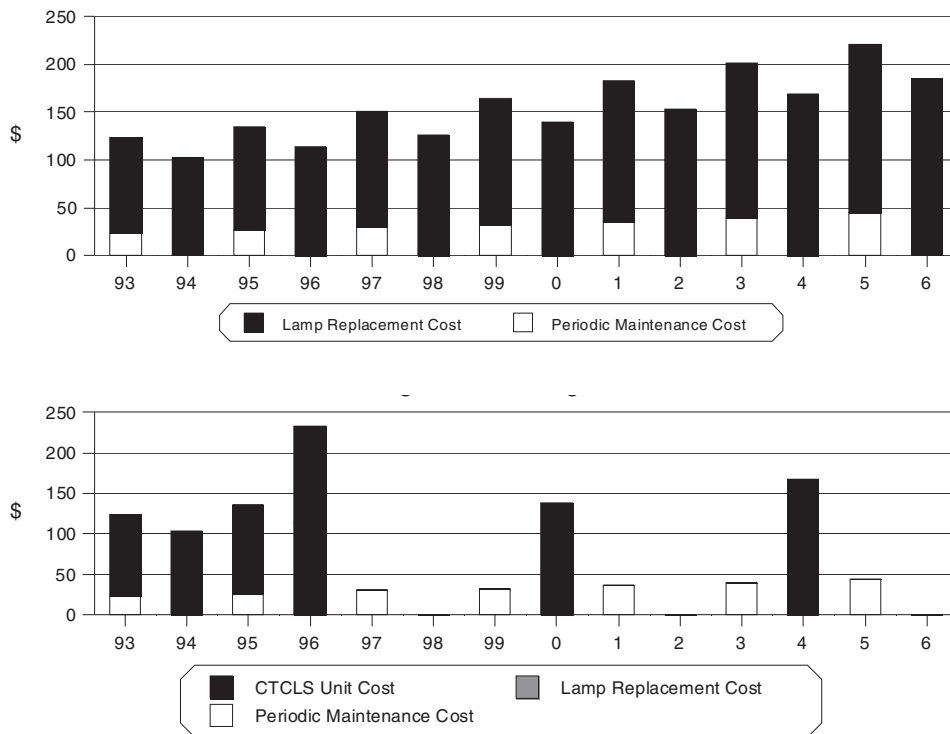

Figure 1

Historical and expected lamp maintenance expenditures. Top: Standard three-lamp signal head. Bottom: Three-lamp signal head using the IDEA product.

AUTOMATED BRIDGE DECK ANTI- AND DEICING SYSTEM

NCHRP-IDEA Project 27

Rand Decker

University of Utah, Salt Lake City, Utah

This project developed and tested an automated bridge deck anti- and deicing system. The system uses accepted deicing liquids, such as sodium or magnesium chloride, and traditional spray application techniques coupled with a modern roadway weather information system (RWIS) and novel data communication and process control to perform the task. Fixed snow and ice control systems are used in Western Europe to spray bridges with liquid snow and ice control materials. This system improves European practices and adapts them to U.S. highway practice. The innovative element of the system includes the provision for automated process control. The decision to apply anti- and deicing fluid to the bridge can be controlled by a knowledge-based algorithm (Figure 1), initialized on a process control computer located at the bridge. The process control algorithm uses data from the sensors of a modern RWIS. In addition, system status checks and manual operations may be carried out remotely using a cellular phone and voice/keypad menu commands. The anti- and deicing process can be initiated from the cab of a vehicle located at the bridge.

A prototype automated bridge anti-icing system was designed for and installed at the 6200 South Street overpass of I-215 in suburban Salt Lake City, Utah. The American Public Works Association, the British Ministry of Highways, the Kansas City Department of Public Works, the Japan Ministry of Construction, the Nevada Department of Transportation, and the Priority Technologies Project Office of FHWA showed interest in using the system for road applications. The final report is available from the National Technical Information Service (NTIS # PB99-130718).

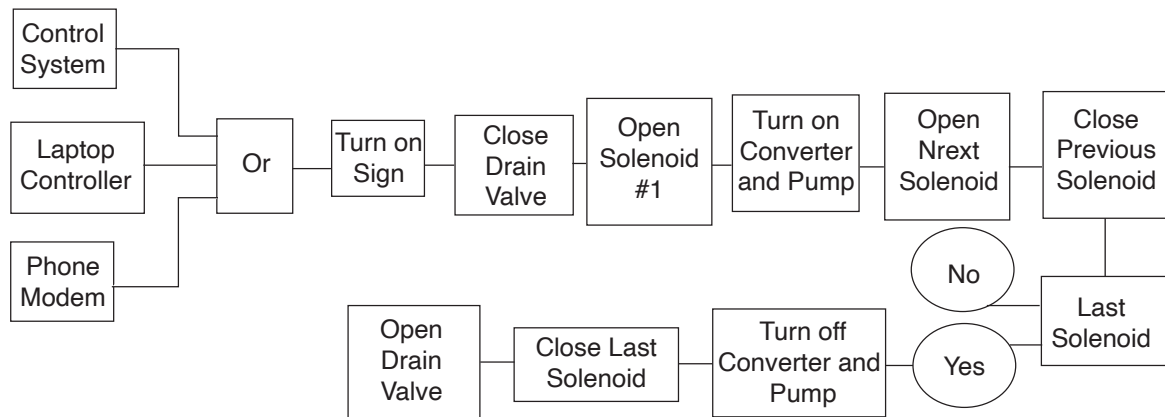

Figure 1

Spray system controller flowchart.

CORROSION-RESISTANT LOW-CARBON STEELS FOR CONCRETE REINFORCEMENT

NCHRP-IDEA Project 28

Gareth Thomas [Tel.: (510) 486-5696, Fax: (510) 653-0965] and David Trejo
University of California, Berkeley, California

This project designed and produced dual-phase ferritic martensitic (DFM) reinforcing steel with improved mechanical properties and corrosion resistance. DFM steel is a low-alloy, low-carbon steel produced by simply quenching the alloy from the two-phase ferrite/austenite field, thus producing a mixture of ferrite and martensite. The major strength source in the DFM structure originates from the presence of the inherently strong martensite phase, which provides the load-carrying constituent of the alloy. The soft ferrite phase provides the alloy with ductility.

Electrochemical evaluations were performed for in situ and ex situ conditions. The ex situ electrochemical test results provided different conclusions on the performance of the reinforcing steels. Anodically polarizing the steels in a de-aerated, decanted cement solution with 3.5 percent NaCl indicated that the DFM steel is more resistant to corrosion (Figure 1), while the ASTM A615 steel shows substantial corrosion products from the exposure. ASTM G-61 results indicate that the DFM steel is more susceptible to chloride-induced localized corrosion in the decanted, de-aerated cement solution. The ASTM G-61 results did not correlate with the in situ testing results and further investigations are required to determine these discrepancies.

In situ testing included Lollipop mass loss testing, Southern Exposure macrocell current testing, and Southern Exposure mass loss testing. All in situ tests indicated that the DFM reinforcing steel was more resistant to chloride-induced corrosion when embedded in concrete than commercially available reinforcing steels. The investigator negotiated with Nucor Steel, a steel manufacturer, for production of a 50-ton heat of DFM steel. Bars from Nucor were tested for mechanical and conversion properties. The final report is available from National Technical Information Service (NTIS # PB-139060).

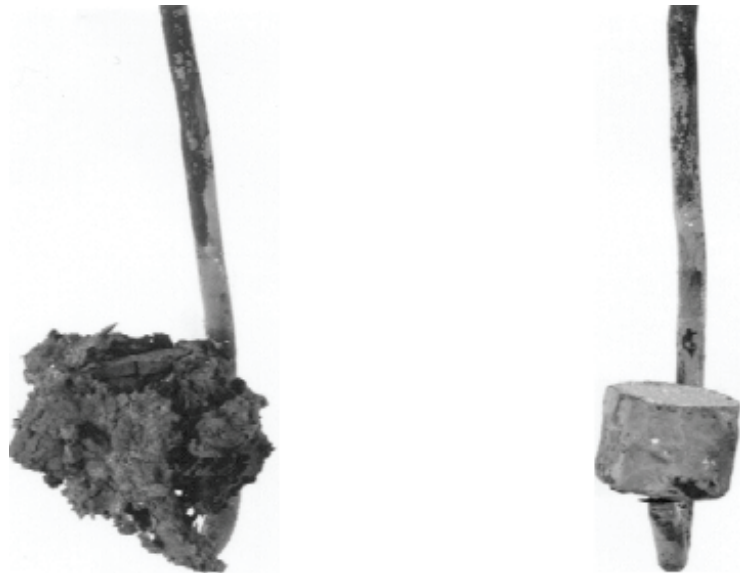

Figure 1

ASTM A615 and DFM steels after ex situ imposed polarization testing.

SUPERELASTICITY-BASED MATERIALS FOR BRIDGE REHABILITATION

NCHRP-IDEA Project 29

Jer-Wen Hsu and Ken Ostowari [Tel.: (517) 349-5653, Fax: (517) 349-5653]
DPD Inc., Lansing, Michigan

Parviz Souroushian

Michigan State University, East Lansing, Michigan

The project developed and demonstrated the application of superelastic shape-memory alloys for the rehabilitation of bridge structures. These materials undergo phase transformation under stress and, after an apparent plastic deformation, return to their original shape when heated (Figure 1). A nickel-titanium-chromium alloy was selected and optimized based on strength and elongation capacity requirements. Structural design procedures for rehabilitation based on superelastic post-tensioning systems as well as rehabilitation schemes using shape-memory and superelastic alloys were developed. Results of tests on concrete beams demonstrated the effectiveness of rehabilitation by shape-memory reinforcement in eliminating excess deformations and crack widths after failure. The beams satisfied all the serviceability and strength requirements under twice the original live load after they were repaired. Work on using superelastic (in place of shape memory) reinforcement for rehabilitation showed that the superelastic reinforcement was able to recover up to 8 percent strain, which is estimated to be adequate for self-repair after substantial cracking and deformation. The superelastic reinforcement system was also processed into polymer matrix composite sheets and glued onto concrete structures for rehabilitation and self-repair. Testing verified applicability of the composite system to the self-rehabilitation technology. Large-scale demonstration of the rehabilitation technology in collaboration with the Michigan DOT was performed in a follow-up IDEA project. The final report is available from the National Technical Information Service (NTIS # PB98-13508).

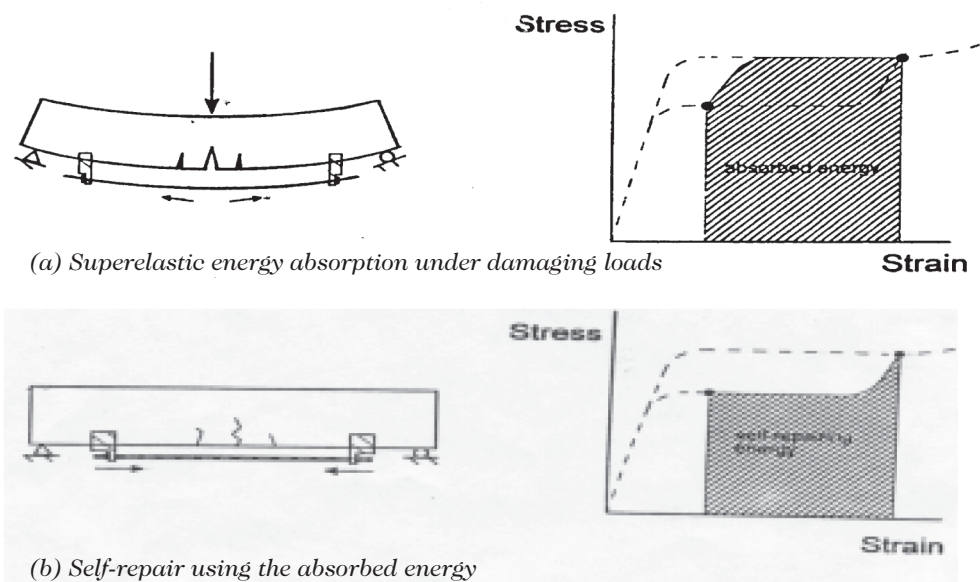

Figure 1

Schematics of the superelasticity-based post-tensioning system.

RAPID REPLACEMENT COMPOSITE BRIDGE NO. 1

NCHRP-IDEA Project 30

Jerry D. Plunkett [Tel.: (913) 483-2589, Fax: (913) 483-5321]

Kansas Structural Composites Inc., Russell, Kansas

This project designed, fabricated, and tested a lightweight composite bridge made of fiberglass-reinforced polymer honeycomb structural panels. The composite bridge was designed in accordance with U.S. Highway Bridge Code HS-25. The key strength requirement was that the span to deflection ratio be 750 under a 40,000-pound load. The bridge was constructed over No-Name Creek in Russell County, Kansas, using three fiberglass honeycomb panels with interlocking edges. Each panel was about 23 feet long and 9 feet wide. The bridge installation time was less than six hours. The bridge performance was tested by driving heavy vehicles onto the bridge panels and measuring the deflections (Figure 1). The performance measurements were within the bridge code requirements. The bridge is now open to traffic. A ribbon-cutting ceremony was performed in December 1996. A supplemental award (NCHRP-IDEA Project 46) was made to prepare specifications and guidelines for installing the composite bridge and for field evaluating the honeycomb panels in bridge decks on highway bridges in Kansas in coalition with the Kansas Department of Transportation. The final report is available through the National Technical Information Service (NTIS # PB97-201511).



Figure 1

Composite bridge under test in Russell, Kansas.

COST-EFFECTIVE MICROWAVE SENSOR TO DETECT HIGHWAY ROAD CONDITIONS

NCHRP-IDEA Project 31

Robert Kubichek [Tel.: (307) 776-3182, Fax: (307) 766-4444] and
Suzanne Yoakum-Stover, University of Wyoming, Laramie, Wyoming

This project developed a method using active microwave sensing technique to measure moisture, snow, and ice accumulation on rural highways (Figure 1). The system uses a low-power microwave transmitter and incorporates neural network and pattern recognition techniques for assessing road surface conditions. The basic system was designed, built, and, after laboratory testing, installed at an outdoor location to collect data. Pattern recognition techniques were applied to the data to identify road conditions based on microwave signatures and yielded 80-90 percent accuracy in detecting ice, snow, wet, and dry road conditions. The classifier's accuracy was improved to over 95 percent by using a neural network technique. Several configuration modifications were made to the system to improve its performance. Field test of the system was conducted in cooperation with the Wyoming DOT during the 1997-98 winter season. Several companies have expressed interest in collaborating in commercializing the technology. However, additional design optimization and field tests are need to implement this technology. The project received media attention through regional newspaper articles, TV and radio segments, and also was described in journal articles including the October 1997 issue of Popular Science. The final report is available from the National Technical Information Service (NTIS # PB98-141187).

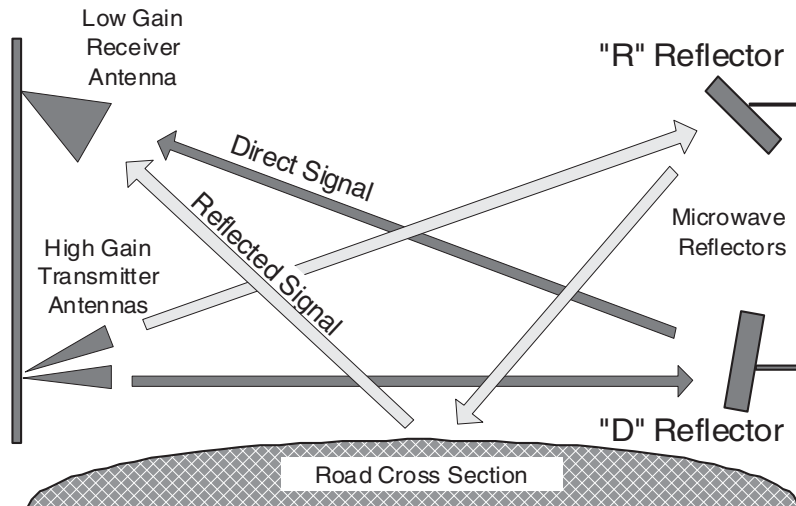

Figure 1

Antenna and reflector geometry, showing reflected and direct paths. Shown is the 10-GHz system; an identical 2-GHz system is implemented using dish antennas.

TESTING AND TRIAL DEPLOYMENT OF A COST-EFFECTIVE AND REAL-TIME ASPHALT PAVEMENT QUALITY INDICATOR SYSTEM

NCHRP-IDEA Project 32

Harry Apkarian [Tel.: (518) 370-5558, Fax: (518) 370-5538], Raymond J. Piasecik, and Frank S. Ralbovsky, TransTech Systems Inc., Latham, New York

The project designed and tested a low-cost pavement quality indicator based on capacitance energy dissipation to measure density of asphalt pavements as a rapid, convenient, and safe alternative to nuclear gauge. A prototype system was designed (Figure 1) and tested on calibrated hot-mix asphalt cores of various thicknesses as well as on a variable-density stack of thin glass plates separated by measured air gaps to verify the system's accuracy, repeatability, temperature stability, sensitivity, and time stability. Also, the effects of various probe configurations and carrier frequencies were investigated. The prototype was subjected to preliminary field tests, and modifications of the system were made that included fine-tuning of the electrical circuit. Three prototype units were fabricated for field evaluation. The field test results were carried out at six sites in Nevada, New York, and Indiana. The field results showed that the instrument measures to a 2.5-in. depth at a speed of about five seconds per reading with good accuracy and reproducibility. The field performance was unaffected by temperature and moisture variations. The probe and the sensor circuit were redesigned to improve their accuracy. A market research study was conducted to determine the competition and demand for the IDEA product. The final report is available from the National Technical Information Service (NTIS #PB97-201503).



Figure 1

Advanced prototype of TransTech System's pavement quality indicator.

EVALUATION OF A NEW REHABILITATION TECHNOLOGY FOR BRIDGE PIERS WITH COMPOSITE MATERIALS

NCHRP-IDEA Project 33

Roberto Lopez-Anido, Rakesh Gupta,
Hota V.S. GangaRao [Tel.: (304) 293-7608, Fax: (304) 293-7609]
Udaya B. Halabe, Sachin Kshirsagar, and Reynold Franklin
West Virginia University, Morgantown, West Virginia

This project evaluated a bridge rehabilitation technology using glass fiber-reinforced fabric encasing on deteriorated bridge columns and piers. Laboratory test results showed significant increase in compressive strengths of concrete cylinders with composite wraps. The composite bond integrity under various environmental conditions was also established. The composite fabric rehabilitation technology was field tested in collaboration with the West Virginia DOT on Pond Creek Road bridge in Wood County, West Virginia. Three columns of the bridge were hand-wrapped with composite fabric (Figure 1) and three additional columns with composite shells. The repaired columns were monitored for durability and bond integrity. Results showed excellent performance. The final report is available from the National Technical Information Service (NTIS # PB2000-103402).



Application of fiber composite wrap on Pond Creek Bridge.



Pier concrete column after wrapping.

Figure 1

Field installation of the composite wrap rehabilitation technology.

HIGHWAY GUARDRAIL INFRASTRUCTURE: SAFER TERMINAL DESIGNS

NCHRP-IDEA Project 34

James F. Wilson [Tel.: (919) 660-5194, Fax: (919) 660-5219]

Duke University, Durham, North Carolina

This project developed a unique class of guardrail terminal retrofits suitable for secondary roads (Figure 1). These new terminal structures do not penetrate errant vehicles but bend upon impact and form sufficient frontal area to mitigate vehicle spearing. Made of mild steel, these terminals curve away from the direction of traffic flow, have variable depth corrugations, have an increasing flare toward the impact end, and have breakaway supporting posts. Low-speed crash tests were performed on half-scale terminal models in which the test car, traveling at about five mph and without bumper shock absorbers, impacted the models head-on. These results showed that the plastic failure zones occurred further toward the tip of impact than for static loading, or at about the two-thirds point from the fixed end.

The ideal final design of a guardrail will incorporate the following features.

- A retrofit that is low cost, simply fabricated, and easily installed.
- A retrofit that buckles plastically near mid-length.
- A retrofit that helps redirect impacting vehicles and minimizes fatalities for their occupants.
- A retrofit that limits the ridedown deceleration of the impacting vehicle to 15 g.

The product is available for potential product developers for licensing to manufacture and commercialize the product. The final report is available from the National Technical Information Service (NTIS # PB98-139058).

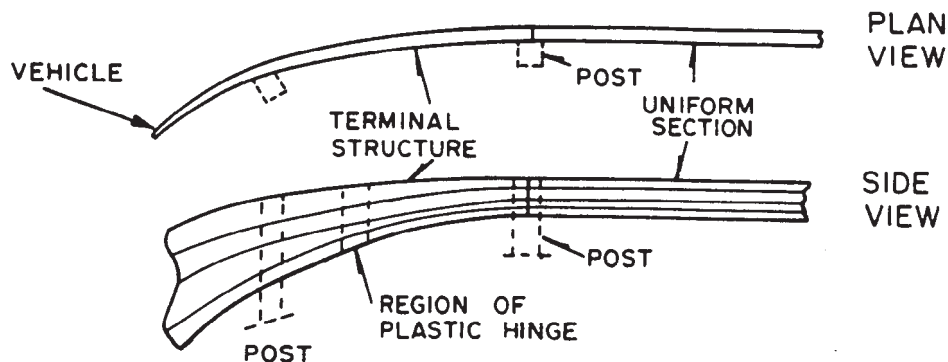

Figure 1

A terminal structure concept designed to avoid vehicle spearing.

IN-SERVICE REPAIR OF HIGHWAY BRIDGES AND PAVEMENTS BY INTERNAL TIME RELEASE OF REPAIR CHEMICALS

NCHRP-IDEA Project 37

Carolyn Dry [Tel.: (217) 333-1913, Fax: (217) 244-2204]

Illinois Universities Transportation Research Consortium, Chicago, Illinois

This project evaluated the concept of self-repairing, concrete-containing fibers filled with adhesives (Figure 1) in large-scale laboratory and field tests. Four specific applications for this concept were explored in the laboratory and field experiments. In frames in the laboratory, it was shown that adhesive release from ruptured fibers helped distribute stress over the entire structure. In four full-scale bridge decks, the adhesive-filled tubes were put near the surface to function as creators of automatically fillable control joints. Surface-shrinkage cracking acted to pull the brittle tubes apart and the sealant/adhesive flowed to fill the cracks. In another application, the adhesive-filled tubes were placed in the body of the deck to break due to shear cracking and repair these cracks. This type of release not only strengthened the decks but also distributed the stress to other locations. In the final application, large beams containing adhesive-filled tubes were tested to failure. The results showed added strength due to release of adhesives. The study also established the survival of adhesive-filled tubes during mixing in the concrete mixer, maintenance of the liquid phase of the adhesive, ease of finishing the concrete containing adhesive-filled fibers. Long-term field evaluation of bridge decks and pavements in a highway environment is needed to implement the rehabilitation technology. The final report is available from the National Technical Information Service (NTIS # PB2001-108551).

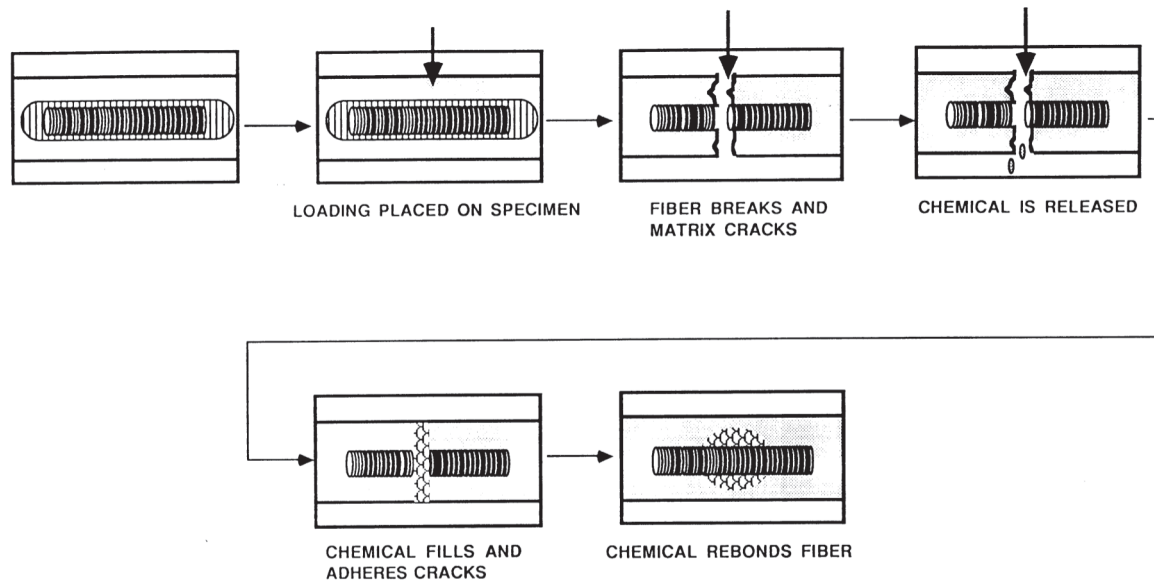

Figure 1

Concept of in situ self-repair of concrete by adhesives in embedded hollow fibers.

PAINT REMOVAL FROM STEEL STRUCTURES: TESTING AND DEMONSTRATION OF ELECTROSTRIP™ PROCESS

NCHRP-IDEA Project 38

Rudolf Keller [Tel.: (724) 335-2666, Fax: (724) 335-8402] and Brian J. Barca
EMEC Consultants, Export, and New Kensington, Pennsylvania

This follow-on IDEA project demonstrated the field application of an electrochemical paint removal process, developed in an earlier IDEA project (NCHRP-IDEA 23). Equipment components to treat up to 50 ft² in one application were acquired and preliminary field tests were performed in Pennsylvania and Virginia. Based on test results, supplies and equipment were selected for a full-scale field demonstration to remove paint from an area of 800 ft² at the I-66 Westmoreland Street overpass in Arlington, Virginia. The field demonstration was successfully carried out in May 1998, in collaboration with Virginia DOT (Figure 1). A showcase event, highlighting the IDEA technology and organized by the Virginia DOT, preceded the field demonstration. The test was completed ahead of schedule, and results were consistent with the targeted removal rate of 40 ft² per hour. Prior to the field demonstration, tests were performed to monitor environmental and occupational exposure. The exposure of personnel was well below the specified OSHA level for particulates and no changes were detected in soil samples.

Cost projections indicate a competitive price of \$7 to \$10 per ft² for full paint removal and repainting and are comparable to quoted average costs for traditional abrasive blasting. However, full commercial implementation will require scale-up equipment and additional process optimization. Additional process demonstrations will also be needed on a non- or near-competitive basis. The final report is available from the National Technical Information Service (NTIS # PB99-117087).



Figure 1

Treated area after initial cleaning.

ESTIMATING TRUCK ATTRIBUTES FROM BRIDGE STRAIN DATA USING NEURAL NETWORKS

NCHRP-IDEA Project 40

Ian Flood [Tel.: (352) 392-7287, Fax: (352) 392-9606]

University of Florida, Gainesville, Florida

This project developed a neural network-based method of estimating truck attributes (such as axle spacing and axle loads) from strain response of the bridge over which the truck is traveling. The research showed that this could be accomplished fairly accurately using a two-layered artificial neural network (Figure 1). In particular, the EHAM (an extended Hamming network) method provided results as reliable as RGIN (a radial-Gaussian network that uses incremental training algorithm) method for classifying trucks and outperformed RGIN in the speed with which it can develop a working model for the bridge. However, work on improving the classification accuracy (and, thus, ultimately the accuracy of estimates of truck attributes such as axle loads and spacing) by allowing a SORG (a self-organizing network) method to develop its own classification system for trucks were inconclusive. The project generated interest from the industry, and an international consortium explored the possibility of adopting and implementing this technology. The final report is available from the National Technical Information Service (NTIS # PB2000-103400).

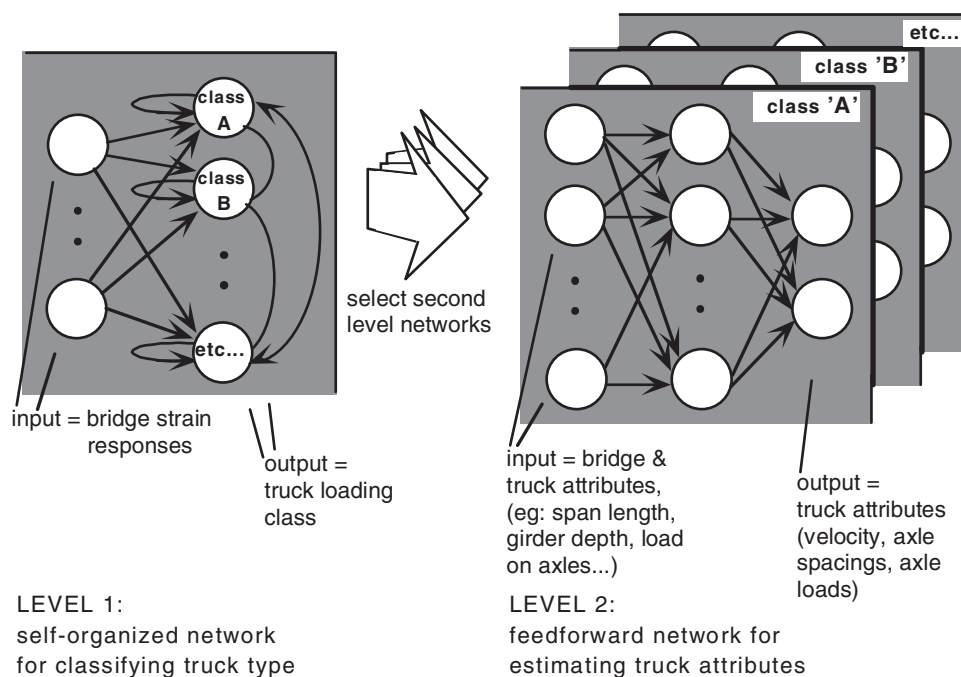

Figure 1

Architecture of proposed networking system.

FIELD TESTING WITH THE DUOMORPH: A SELF-CONTAINED PORTABLE DEVICE FOR SHRP BINDER TESTING

NCHRP-IDEA Project 41

Samuel H. Carpenter [Tel.: (217) 333-4188, Fax: (217) 333-1924]
University of Illinois, Urbana-Champaign, Illinois

This project refined and tested a portable Duomorph Asphalt Rheology Tester (DART) developed in an earlier IDEA project (NCHRP-IDEA 17). The device tests rheological properties of asphalt for pavement construction. The Duomorph is a piezoelectric sensor that can be embedded in a viscoelastic material to determine the modulus and phase angle of the material, the same data required for the Superpave binder grading. A testing program demonstrated that DART provided good stiffness values that compared favorably with dynamic shear rheometer and bending beam test data over the range of temperature of interest. The equipment's data repeatability was better than that of the dynamic shear rheometer. The phase angle data was, however, inconsistent. To address this inconsistency, an analytical scheme based on viscoelastic properties and a three-dimensional finite element analysis was developed. The results show that the analytical approach can model the DART behavior precisely. The system was automated for data collection and reduction capabilities.

The DART has the potential to provide a portable field device that can be used at a plant or refinery to verify the more extensive laboratory testing program used for material certification. It can be used on modified asphalts with particulate matter such as crumb rubber modified binders. It can be used at the plant to test asphalt that has been blended with a polymer to verify the blending process. It can be used on material sampled directly from a tanker to verify that the material is the same as what was specified. This ability to provide a rapid indication of product acceptability before use could result in significant savings by avoiding using materials that later are proven to be unacceptable. This use as a fingerprinting tool for monitoring material variability using the same material properties that are determined in the full grading acceptance scheme provides a unified process in a real-time format not previously possible. Implementation of the system will require a commercial prototype and field trials. The final report is available from the National Technical Information Service (NTIS # PB2001-101279).

DUAL-CORE FIBER OPTIC WIM SYSTEM

NCHRP-IDEA Project 42

Ramesh B. Malla [Tel.: (860) 486-3683, Fax: (860) 486-2298] and Norman W. Garrick
University of Connecticut, Storrs, Connecticut

This project incorporated a new optical fiber design in a weigh-in-motion (WIM) system and tested its performance under simulated highway conditions. The fiber design consisted of a dual-core system using two light-guiding regions of different effective optical path lengths. This design enables us to measure magnitude as well as positions of forces that are applied at multiple locations along a single fiber and to use a single light source and photodetector. A prototype fiber optic WIM system was designed, fabricated, and tested under both static loading and in an actual vehicle (Figure 1). The static loading tests showed good correlation between load and changes in optical signal. The location of the load was also determined fairly accurately. Changes in optical signal under vehicle testing were similar to those under static loading. The system was optimized and refined with attention to the optical set-up, data gathering capability, and fiber optic configuration. The results showed a good potential of the WIM system for determining the magnitude and location of vehicle loads. However, additional refinements and prototype tests are needed before the technology will be ready for field implementation. The final report is available from the National Technical Information Service (NTIS # PB2001-100953).

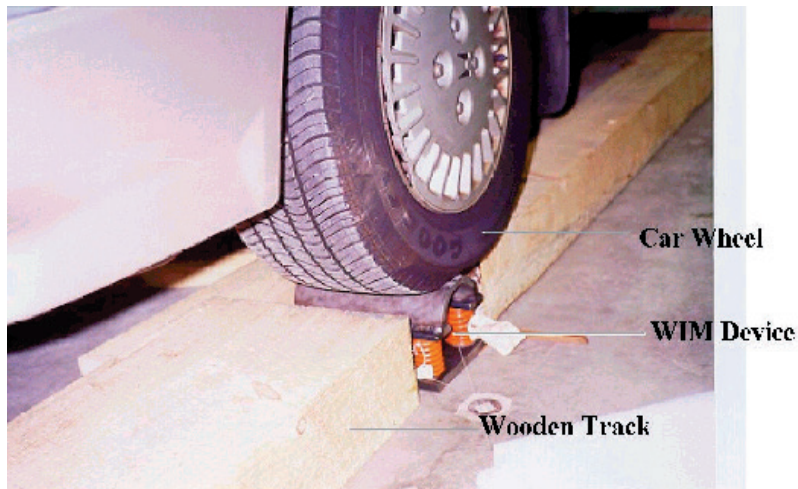

Figure 1

Car wheel testing in progress.

ROBOTIC SYSTEM FOR UNDERWATER BRIDGE INSPECTION AND SCOUR EVALUATION

NCHRP-IDEA Project 43

James DeVault [Tel.: (913) 532-4594, Fax: (913) 532-1188]

Kansas State University, Manhattan, Kansas

The project investigated the feasibility of using a semiautonomous robotic system to position a sensor platform in close proximity to underwater bridge support structures while providing video or other sensory information to support evaluation and documentation of structural condition, including scour. The primary system consists of two or more identical mobile robots designed to travel along opposite surfaces of submerged structures while connected to one another by a cable and winch system (Figure 1). Each robot contacts the surface through cleated rubber tracks (or, alternatively, wheels and rubber tires) that are driven by internal motors. Tensioning the cables that connect the two robots provides traction. In response to an operator's command to move to a new position, the robot team automatically coordinates both movement and cable tension. A graphical user interface provides the operator with status information and control options. This robotic system may be used to augment traditional diver inspections, thereby reducing diver time and cost and enhancing safety.

Two prototype systems were constructed and tested, and the findings applied to development of a third system of significantly different design. This system has a broad array of potential applications for inspection of submerged physical structures, such as bridge substructures, pipelines, water towers, industrial smokestacks, nuclear cooling towers, oil rigs, oil derricks, floating platform support structures, and docks.

Initial estimates of the manufactured costs of the system range from \$25,000 to \$50,000. The final report is available from the National Technical Information Service (NTIS # PB99-130700).

Figure 1

Two mobile robots connected to each other travel opposite sides of a structure to provide video and sensory information to remote users.



ROLLER-MOUNTABLE ASPHALT PAVEMENT QUALITY INDICATOR USING DIFFERENTIAL MICROWAVE SIGNALS

NCHRP-IDEA Project 44

Edward J. Jaselskis [Tel.: (515) 294-5225, Fax: (515) 294-8000]
Iowa State University, Ames, Iowa

This project developed a technique using microwave sensors installed on a pavement roller for real-time measurement of asphalt pavement density. Two microwave antennas, one in the front and the other at the back of a paving roller, measure microwave signals reflected from asphalt, and the difference between the signals is correlated with the degree of compaction of asphalt pavement (Figure 1). Following laboratory evaluation of the interaction of microwaves with asphalt, a prototype system was designed and field tested. The field tests verified a relationship between asphalt pavement density and microwave signal variance. The signal variance decreased with increasing asphalt density, but increased rather abruptly near the point of optimum compaction. These characteristics can be used to develop a non-contact method for a real-time assessment of the degree of compaction of asphalt pavements. However, additional system refinement and field evaluation are necessary to make this technology fully implementable. The final report is available from the National Technical Information Service (NTIS # PB2000-10340).



Figure 1

Prototype system for asphalt pavement density determination.

PERFORMANCE EVALUATION OF BASALT FIBERS AND COMPOSITE REBARS AS CONCRETE REINFORCEMENT

NCHRP-IDEA Project 45

Vladimir Brik [Tel.: (608) 244-1349, Fax: (608) 244-9071]

Research and Technology Inc., Madison, Wisconsin

V. Ramakrishnan

South Dakota School of Mines and Technology, Rapid City, South Dakota

This project evaluated the suitability of basalt fibers and basalt fiber composite rebars in concrete as an economical and durable alternative to reinforcing steel. Concrete specimens reinforced with basalt fiber composite rebars and basalt fibers (up to 2 percent by volume) were tested in accordance with ASTM standard test procedures. The basalt composite rebar exhibited tensile strength three times that of steel rebar. However, the mechanical performance of prestressed specimens was poor because of creep developed at the cement matrix-basalt composite interface. This limits its application for prestressed concrete reinforcement. Use of basalt fibers in fiber-reinforced concrete appears promising. Basalt fiber-reinforced concrete specimens showed a significant increase in toughness and impact strength (Figure 1) and a reduction in crack intensity and size as compared to plain concrete. The overall performance of basalt fibers in concrete was found to be similar to that of polypropylene fibers. It appears feasible to use locally available basalt mineral from northern Wisconsin and Minnesota for manufacturing basalt fibers and basalt fiber composite materials. The final report is available from the National Technical Information Service (NTIS # PB99-145104).

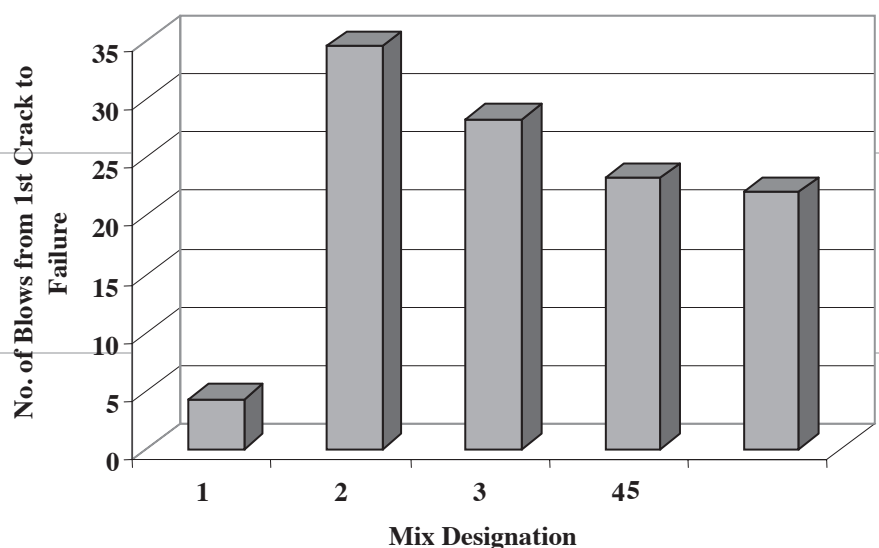

Figure 1

Toughness and impact test results for basalt fiber-reinforced concrete (Mix designations #1, 2, 3, 4, and 5 correspond to basalt fiber contents of 0%, 0.5%, 0.4%, 0.25%, and 0.1%, respectively).

TESTING, EVALUATION, AND INSTALLATION OF FIBER-REINFORCED POLYMER HONEYCOMB COMPOSITE PANELS IN BRIDGE DECK APPLICATIONS

NCHRP-IDEA Project 46

Jerry D. Plunkett [Tel.: (785) 483-2589, Fax: (785) 483-4535] and Stephen R. Gill
Kansas Structural Composites Inc., Russell, Kansas

This follow-on project of a previous IDEA project (NCHRP-IDEA 30) performed field testing of bridge deck panels made from fiber-reinforced polymer (FRP) honeycomb composites. Existing methods of rehabilitating bridge decks are time consuming and create long traffic delays. Using the system developed under this project, it will be feasible to rebuild bridge decks rapidly and to greatly reduce these traffic delays. The project was carried out in collaboration with the Kansas DOT and involve re-decking two highway bridges, each 32 ft wide and 45 ft long, in Crawford County. Lightweight deck panels of FRP honeycomb sandwich construction, approximately 5 in. thick with a 3/8-in. polymer concrete wear surface, were fabricated. The total weight for the deck for each of these bridges was approximately 25 kip and replaced an estimated 88 kip of existing roadbed—a 70 percent reduction in dead load. The decks were supported, with an attachment device, on saddles that are also of FRP honeycomb construction and designed to straddle the existing beam fringes. The attachment device is a clamp that can be installed from the deck surface. The decks were installed on both bridges in the fall of 1999, and the highway was reopened to traffic after installation. The performance of the bridges is being monitored by the Kansas DOT. The composite bridge project has received considerable media coverage and several awards for technology innovation. A Web site (www.ksci.com/crawford.html) was set up to provide updated information on the project.

The technology developed through this project was used for two bridge decks in Missouri and one in West Virginia. The FRP composite technology permits the removal and replacement of damaged bridge deck panels and the removal and re-use of bridge decks from bridges that are no longer in service or that are to be upgraded. Bridges will no longer be torn down but can be removed and re-used easily and cheaply. Thus, bridges using this technology will possess a large salvage/re-use value. The final report is available from the National Technical Information Service (NTIS # PB2000-108042).

PAVEMENT QUALITY INDICATOR: FIELD OPERATIONAL TESTING AND PRODUCT TRANSFER

NCHRP-IDEA Project 47

Harry Apkarian [Tel.: (518) 370-5558, Fax: (518) 370-5538] and Peter Sawchuk
TransTech Systems, Latham, New York

This is a follow-on project for field testing and implementation of a pavement quality indicator (PQI) system developed in a previous IDEA project (NCHRP-IDEA 32) for real-time asphalt pavement density measurements (Figure 1). The project was carried out in collaboration with the New York State Energy Research and Development Authority and the U.S. Army Corp of Engineers. The test program produced several design improvements that included sensing probe design, averaging capability of microprocessor logic, backlit readout screen, and calibration capability enhancement. Test results showed that the equipment performed equal to or better than the nuclear density gauge both in accuracy and reproducibility. The equipment is commercially available. More than 500 units have been sold both in the United States and abroad. The PQI system was also evaluated for field performance by a number of states in a pooled-fund study. The final report is available from the National Technical Information Service (NTIS # PB99-117095).



Figure 1

Pavement quality indicator prototype.

FIELD TRIAL OF SHAPE MEMORY-BASED REHABILITATION SYSTEM

NCHRP-IDEA Project 48

Ken Ostowari [Tel.: (517) 349-5653, Fax: (517) 349-5653]
DPD Inc., Lansing, Michigan

Parviz Soroushian
Michigan State University, East Lansing, Michigan

This project demonstrated the application of superelastic shape memory alloys for the rehabilitation of bridge structure. Shape memory alloys recover deformations induced at lower temperatures upon heating above a transformation temperature; restraint of this shape recovery generates relatively large stresses. These stresses are used here to transfer corrective forces to structural systems for strengthening and repair effects. For this purpose, shape memory rods are pre-elongated, anchored to the structure, and subjected to electrical resistance heating to transfer corrective forces to the structure. The project used iron-based shape memory alloys of relatively low cost; the alloy composition was selected to yield relatively high and stable levels of restrained shape recovery stresses. Laboratory tests verified the ability of pre-elongated rods anchored onto damaged structural systems to restore structural integrity through application of corrective forces. Subsequent damaging effects could also be overcome by electrical resistance re-heating of rods.

A reinforced concrete bridge structure with beams lacking sufficient shear strength at longitudinal bar cut-off locations was selected for field demonstration of the technology. A design methodology was developed and verified through laboratory tests simulating conditions of the selected bridge structure. Subsequently, a detailed design was developed, and the approach was successfully implemented under field conditions (Figure 1). The final report is available from the National Technical Information Service (NTIS # PB2000-105060).



Figure 1

Field implementation of shape memory-based rehabilitation technology (final field set-up for application of local corrective forces).

AUTOMATION OF LEGENDS PAINTING

NCHRP-IDEA Project 49

Duc Huynh [Tel.: (510) 438-9714, Fax: (510) 438-0194]
Pavement Marking Technologies Inc., Menlo Park, California

This project developed and tested an automated, computer-controlled, robotic prototype system (Roadwriter) with multiple axis movement capability to paint patterns and legends on highway pavements (Figure 1). Initially, a prototype system was designed, assembled, and tested. The test performance data were used to define operational algorithm, performance criteria, and system integration guidelines and to develop necessary hardware and software to produce a second-generation prototype. The new prototype showed improved features regarding safety, speed, quality, cost, and versatility and included a laser guidance system that allowed the operator to visually locate and orient the position where the legends were to be painted. Other improvements included a new spray head, a new long-life tip, and a new less temperature-sensitive marking material. The computer system was also miniaturized and additional software was developed to improve the “smoothness” of the system. The Roadwriter system is estimated to cost about \$300,000 and is believed to pay for itself in 18 months time not counting the savings resulting from improved worker, driver, and pedestrian safety and from reduced injuries and property damage. Additional refinement and field testing are needed for a full implementation of this technology.



Figure 1

Truck-mounted RoadWriter™ prototype system in field operation.

DAMPER SYSTEMS FOR SUPPRESSION OF BRIDGE STAY CABLE VIBRATIONS

NCHRP-IDEA Project 50

Habib Tabatabai and Armin B. Mehrabi [Tel.: (847) 965-7500, Fax: (847) 965-8997]
Construction Technology Laboratories Inc., Skokie, Illinois

This project developed and evaluated damper systems for suppression of bridge stay cable vibrations. Three damping approaches—a tuned-mass damper (TMD), a liquid damper, and wrapping cable with damping tape—were tested using various grout mixes and cable models. In addition, a concept based on cable guide pipe filled with polyurethane material was also evaluated. The latex grout improved damping by about 60 percent as compared to the conventional grout. Use of neoprene washers also improved the damping significantly. However, neither of these improvements was adequate to control rain-wind vibrations based on current criteria. Use of a damping tape on the outside surface of the cable produced no significant improvement. The results show the tuned-mass damper (TMD) system, which can be applied anywhere along the length of the cable, to be the most cost-effective temporary or long-term solution to the rain-wind vibration problem (Figure 1). A follow-on project for field evaluation and implementation of the technology was approved by the NCHRP-IDEA Project Committee. The final report is available from the National Technical Information Service (NTIS # PB2000-15409).

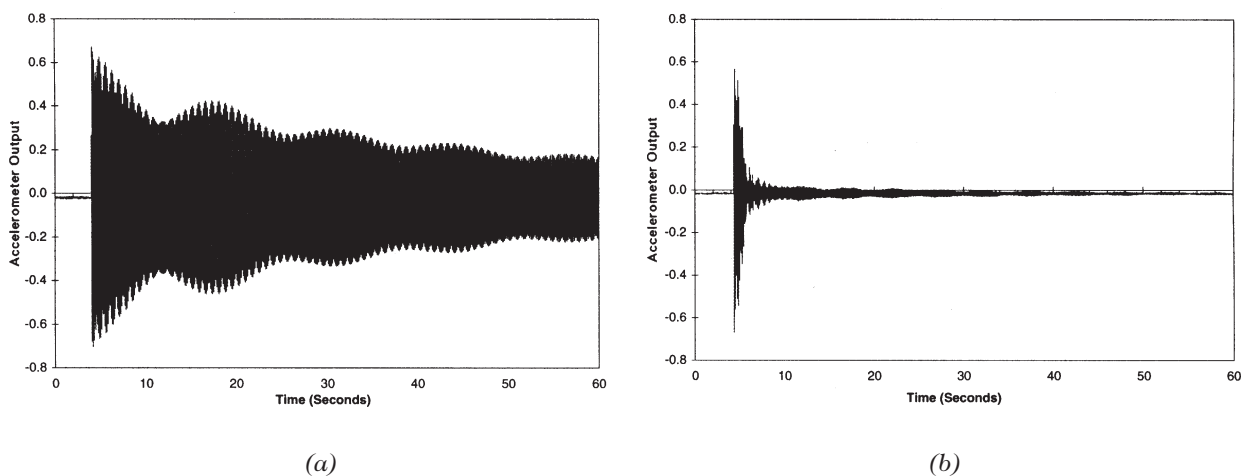

Figure 1

Comparison of cable responses, (a) without TMD; (b) with TMD.

APPLICATION OF ADVANCED COMPOSITES TO STEEL BRIDGE RETROFITTING

NCHRP-IDEA Project 51

Dennis R. Mertz [Tel.: (302) 831-2735, Fax: (302) 831-3640]
University of Delaware, Newark, Delaware

This follow-on project to a previous IDEA project (NCHRP-10) demonstrated the field use of advanced composites to strengthen and stiffen highway steel bridges (Figure 1). An in-service steel bridge was identified for retrofitting and field evaluation in collaboration with the Delaware DOT. Two full-scale steel bridge girders were rehabilitated in the laboratory by bonding carbon fiber-reinforced polymer (CFRP) composite to the top and bottom of the tension flange of the girders. The girders were fatigued and subjected to static tests. Both test data and inspection showed no changes in the overall stiffness or bond integrity after 10 million fatigue cycles. The same girders were also subjected to a sustained load, and strain gauges and load cells were implemented to record any changes over time. After successfully addressing the issues of force transfer, fatigue resistance, and durability, a full-scale rehabilitation of a steel bridge on I-95S over Christina Creek near Newark, Delaware, was carried out using two types of structural adhesives to bond CFRP to steel. Monitoring of the bridge for performance and durability of the CFRP-steel bond will continue for several years. The final report is available from the National Technical Information Service (NTIS # PB2002-103162).



Figure 1

Bridge girders rehabilitated with carbon fiber-reinforced polymer plates.

ENVIRONMENTALLY FRIENDLY PASSIVATING COATINGS FOR STEEL REBARS

NCHRP-IDEA Project 52

James E. Neely, Jr. [Tel.: (724) 482-2163, Fax: (724) 482-2767]
Neely Industries Inc., Butler, Pennsylvania,

Alberto Sagues
University of South Florida, Tampa, Florida,

Rodney Powers
Florida Department of Transportation, Gainesville, Florida, and

Richard Brown
University of Rhode Island, South Kingstown, Rhode Island

This project developed and tested a new class of nontoxic water-based inorganic polymer coatings for corrosion protection of concrete reinforcing steel rebars for highway applications. A.C. (alternating current) impedance spectroscopy and salt fog tests were conducted on polymer coatings applied to steel panels and bars. Based on test results, coating formulations with superior corrosion protection characteristics were identified. Of these, two formulations were selected for evaluation by the ASTM G109 test for corrosion protection. Tests on coated steel reinforcing rebars in concrete were way for over 15 months at the Florida DOT. Initial results showed no noticeable corrosion activity on coated rebars. To accelerate the onset of corrosion, the saline concentration of the test solution was raised. Results to date for coated rebars have been very promising and Florida DOT has decided to continue monitoring of the specimens beyond the completion of this IDEA project.

A number of options for implementing the results within highway practice are possible. Once the passivating coatings are certified for use by the Federal Highway Administration and state departments of transportation, the next step for implementation would be providing commercial quantities of inorganic polymer coatings. One option for Neely Industries Inc. (NI) to provide such quantities would be by licensing the technology to established coating manufacturers a strategy successfully utilized by NI for other product developments. Another option is the formation of a joint venture company to manufacture the coatings. The regional manufacture of coated rebar will be done by licensing individual fabrication and coating companies. The final report is available from the National Technical Information Service (NTIS # PB2001-104274).

NOVEL APPROACH FOR PREDICTING REMAINING LIFE OF CONCRETE BRIDGE STRUCTURES

NCHRP-IDEA Project 54

C. S. Desai [Tel.: (520) 621-6569, Fax: (520) 621-6577], T. Kundu, and M. Keller
The University of Arizona, Tucson, Arizona

This project developed a new approach based on constitutive models and Lamb wave technique that could be used to predict the remaining service life of concrete bridge structures. The prediction is based on the stress-strain response of materials in concrete bridge structures experiencing deterioration due to highway traffic and environmental conditions. The project was focused on establishing the correlation between the Lamb wave data and the disturbance (damage) from the stress-strain, and on the design and integration of the NDT system with a constitutive model. Concrete beams and flat specimens were cast for evaluating stress-strain and Lamb wave propagation characteristics. Tests were performed on specimens under normal conditions and in salt solutions, and data on tension and compression and lamb wave characteristics were collected at various time intervals. A methodology was developed to evaluate stress-strain location, elastic moduli and peak stress (strength) of the material at a given stage during the life of the structure. Results for salt-treated specimens were compared with those for untreated specimens and correlation between mechanical and Lamb wave test data was investigated. It was concluded that the integration of nondestructive testing with constitutive models can form the basis to develop new equipment using Lamb wave technique. The final report is available from the National Technical Information Service (NTIS # PB2002-101163).

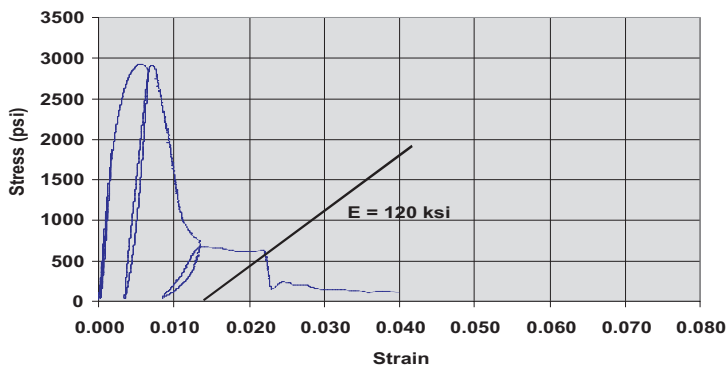

Figure 1

Stress strain response—compression test.

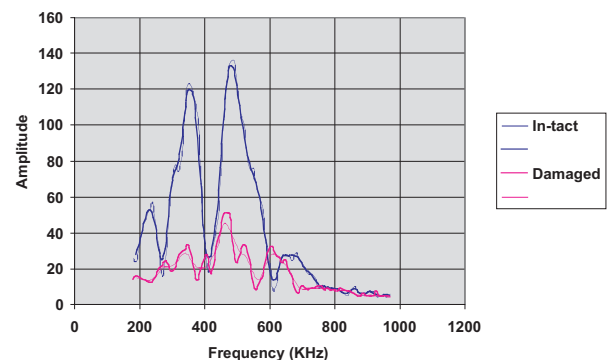

Figure 2

*Voltage amplitude vs frequency:
Incidence angle 25 deg.*

DESIGN, DEVELOPMENT AND VERIFICATION OF AN ADVANCED IN-SITU SHEAR STRENGTH TEST FACILITY FOR ASPHALT CONCRETE PAVEMENTS

NCHRP-IDEA Project 55

A. O. Abd El Halim, [Tel.: (613) 520-5789, Fax: (613) 520-3951], Wael Bekheet, and Yasser Hassan, Carleton University, Ottawa, Canada,

Stephen N. Goodman

Canadian Strategic Highway Research Program, Ottawa, Canada

The project developed a surface plate type method for measuring the in-situ shear strength of asphalt pavements (Figure 1). The device is called the In-Situ Shear Strength/Stiffness Test (InSiSST™). Data collected with the InSiSST™ will provide input for more accurate measurement and performance modelling of in-service pavement performance—the fundamental basis of the SHRP Superpave system. The method involves applying a torque directly to the asphalt pavement surface and relating the maximum applied torque to the shear strength of the asphalt pavement layer. Initially, a preliminary design of a shear test device was developed along with a framework for a set of analytical models to predict pavement performance based on field shear data. Based on test results, the final design of the shear test device was developed and the system was tested to ensure proper functioning of all of its components. Field testing of the prototype system was performed on asphalt pavements at various locations in the United States and Canada.

In addition to IDEA Program funding, the Ontario Ministry of Transportation (MTO) and Regional Municipality of Ottawa-Carleton committed financial and in-kind support for this investigation. Furthermore, a number of independent consultants expressed interest in the potential of the InSiSST™. The final report is available from the National Technical Information Service (NTIS # PB2001-108550).



Figure 1

The in situ shear strength test (InSiSST™) at Carleton University.

BRIDGE INSPECTION WITH SERPENTINE ROBOTS

NCHRP-IDEA Project 56

Howie Choset [Tel.: (412) 268-2495, Fax: (412) 268-3348]
Carnegie Mellon University, Pittsburgh, Pennsylvania

This project developed an automated remote-controlled bridge inspection technology with flexible, jointed, serpentine robotic arms (Figure 1). These new types of robots have multiple joints that enable them to flex, reach, and approach all points on the bridge. Algorithms for the serpentine motion control were developed for a working system. A new method for using roadmaps to perform path planning with snakes, based on density functions, was developed. An inspection of a highway bridge was conducted to determine issues with bridge inspection using serpentine robotic system. The bridge symmetry posed some problem for geometric algorithms that was successfully resolved. A new serpentine robot prototype was designed that represented an improvement over the previous serpentine mechanism developed by the Jet Propulsion Laboratory (JPL). This new design involves an angular bevel joint that utilizes a special kind of angular bevel gear that allows larger ranges of motion and produces a stronger snake robot. A new cellular decomposition suitable for motion planning of serpentine robots was developed. Work on path planning and control of serpentine robot resulted in further improvements. Additional development and testing will be needed for the implementation of this technology in the field.

The developments of this project form the first step towards the envisioned bridge inspection and other similar systems and are critical to the successful transfer to an application program in the field. The technology also holds promise for other applications, such as search and rescue, pipe inspection, and bridge painting. The final report is available from the National Technical Information Service (NTIS # PB2001-104275).

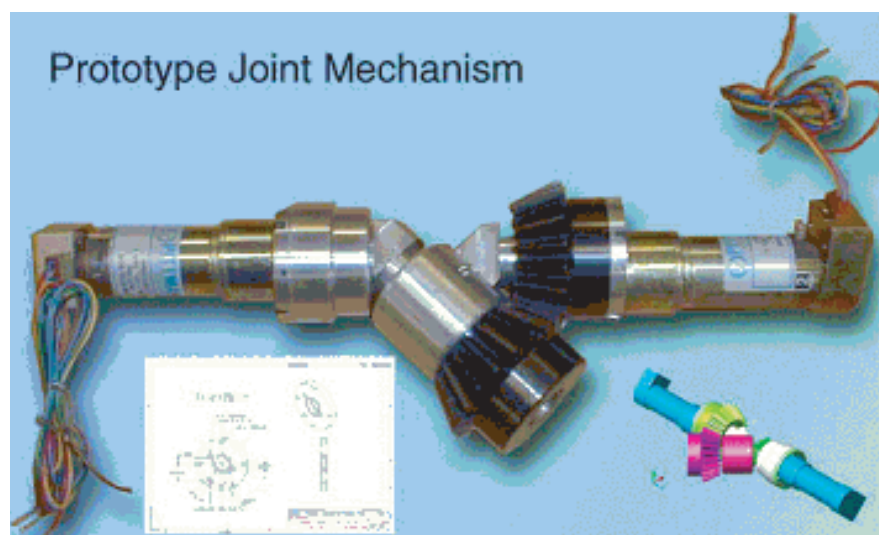

Figure 1

The angular bevel gear provides a wider range of motion and a stronger snake robot than previous designs.

STABILIZATION OF LANDSLIDES USING HORIZONTAL WICK DRAINS

NCHRP-IDEA Project 57

Paul M. Santi [Tel.: (303) 273-3103, Fax: (303) 273-3859]
Colorado School of Mines, Golden Colorado

C. Dale Elifrits
University of Missouri, Rolla, Missouri

This project investigated the use of horizontal wick drains to stabilize slopes and landslides (Figure 1). Several landslide sites, identified with the assistance of the Missouri and Colorado DOTs and the Colorado Geological Survey, were stabilized by wick drains and monitored. The field experience led to several improvements in the design and installation of wick drains. Additional landslides were stabilized in Colorado, and the experience led to further improvements in the installation process. The landslides were monitored for water levels as well as for slope and roadway movements. Simulation and interpretation of rainfall at the test embankment were accomplished, and guidelines for wick layout were developed. The results showed that wick drainage was highly dependent on hydraulic conductivity of shallow soil and that drains significantly lowered the water table and reduced soil settlement. For example, at one of the Colorado sites, the wick drains lowered the water table by 15 feet. A video illustrating the technique for wick drain installation and use was prepared and is available for instructional purposes. The principal investigator has set up a web page that describes and updates the IDEA project activities and illustrates the wick installation process (<http://www.umn.edu/~psanti/wick.html>). The final report is available from the National Technical Information Service (NTIS # PB2002-103444).



Figure 1

Completed landslide drain system in a fan pattern. Note the water exiting the wick drains (inset: closeup of water drainage from a wick drain).

LONG GAUGE-LENGTH INTERFEROMETRIC FIBER-OPTIC SENSORS FOR CONDITION ASSESSMENT OF BRIDGE STRUCTURES

NCHRP-IDEA Project 58

Jeffrey A. Laman [Tel.: (814) 863-0523, Fax: (814) 863-7304], Timothy E. McDevitt, and Karl M. Reichard
Pennsylvania State University, University Park, Pennsylvania

This project developed a long gauge-length sensor system for monitoring the condition of bridge structures (Figure 1). The sensor system was designed and tested to optimize features important for concrete bridge applications and incorporated into a specially designed monitoring system. A concrete test beam was constructed, and techniques for sensor attachment, isolation, entrance, and exit were evaluated for their practicality in field applications. The optical sensors performed well in laboratory tests under dynamic loads responding at all frequencies of interest. The data analysis and correlation showed the system's promise in detecting damage changes in the structure. An in-service concrete bridge near Unionville, Pennsylvania, was identified for instrumenting with the fiber-optic prototype system for field evaluation. The sensor and the data acquisition system functioned well in the field conditions at the bridge. Strain time-history data were successfully collected for several truck passages under normal traffic. The system needs to be made more rugged and further developed for full-scale field deployment with regard to the size of the input and output devices and the sensitivity of the initiation procedure to focus the input light. The final report is available from the National Technical Information Service (NTIS # PB2002-103163).

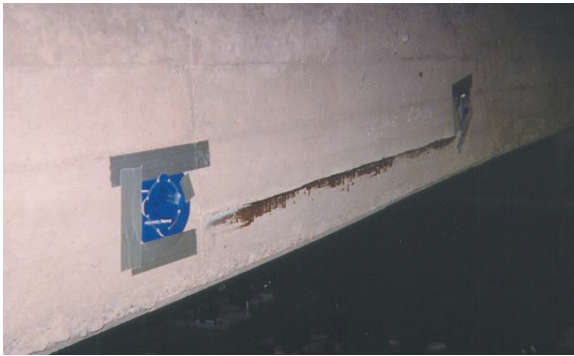

Figure 1

Installed optical sensor.

CONTROL SYSTEMS FOR LIVE LOAD AND LIVE LOAD EFFECTS ON BRIDGES

NCHRP-IDEA Project 59

Andrzej S. Nowak [Tel.: (734) 764-9299, Fax: (734) 764-4292]
University of Michigan, Ann Arbor, Michigan

Funded jointly by NSF and NCHRP-IDEA, this project developed a system for monitoring live load and verifying the live load carrying capacity of highway bridges. The NSF part of the work focused on fundamental work on the development of the truck control system while the IDEA portion dealt with practical applications, field measurements, and integration of the system with the intelligent transportation system (ITS). The field testing program involved verifications of girder distribution factors (GDF), dynamic load factors (DLF), truck load effect on newly applied fiber sheets, and truck load carrying capacity. The individual components of the comprehensive testing program were verified on 17 bridges. The final, multi-objective tests were carried out on a selected structure in Florida. The load was applied in the form of fully loaded (up to the legal limit) trucks. The considered loading combinations include a single vehicle and two trucks side-by-side. The results of these and previous tests indicate that the girder distribution factors (GDF) specified by AASHTO for the spans from 10 to 30m are rather conservative. Dynamic load factors (DLF) were also measured for a single truck and two trucks side-by-side. It was observed that the dynamic load is not related to static load, and therefore DLF (defined as the ratio of dynamic load and static load) decreases for larger static load. Figure 1 shows a plot of DLF against static and dynamic strain recorded for heavy trucks. Deflections due to truck loads are also considerably lower than analytically predicted values. The field tests confirmed that the developed procedures are efficient and can be used as an alternative way to evaluate the adequacy of the bridge.

The control system for highway load effects has already been applied on selected bridges in collaboration with the state DOT's in Michigan, Wisconsin, and Florida. The final report is available from the National Technical Information Service (NTIS # PB2004-102286).

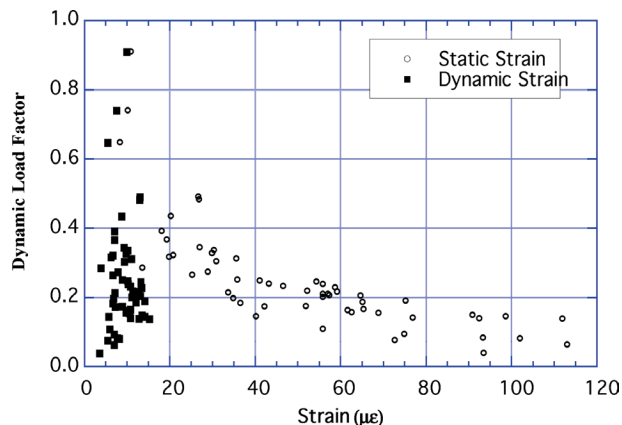

Figure 1

DLF vs. static and dynamic strain.

THE HYBRID-COMPOSITE BEAM SYSTEM

NCHRP-IDEA Project 60

John R. Hillman [Tel.: (847) 722-4072; Email: hillmanjr@hcbridge.com]

Teng and Associates, Inc., Chicago, Illinois

This joint High-Speed Rail/NCHRP IDEA project developed and demonstrated a hybrid-composite beam (HCB) as a structural member for use in railroad and highway bridges (Figure 1). The HCB is comprised of three main subcomponents that are a shell, compression reinforcement, and tension reinforcement. The shell is comprised of a fiber-reinforced plastic (FRP) box beam. The compression reinforcement consists of portland cement concrete, which is pumped into a profiled conduit within the beam shell. The tension reinforcement consists of steel fibers anchored at the ends of the compression reinforcement. The HCB weighs approximately one-tenth of what a typical precast concrete beam weighs for the same span length, improves the speed of construction, and is well suited for modular bridge installation (accelerated bridge construction). In general, HCB is suitable for 50- to 120-ft span bridges for highways and for 30- to 45-ft span bridges for rail.

HCB was successfully tested on a railroad test track in Pueblo, Colorado. Since then, the beams have been installed in 17 highway bridges in nine states (Colorado, Illinois, Kentucky, Maine, Maryland, Missouri, New Jersey, Virginia, and West Virginia) and one Canadian province (British Columbia). At least seven more HCB projects are under consideration for construction in Maine, New Jersey, Washington State, and the provinces of British Columbia, Ontario, and Saskatchewan. The U.S. Army Corp of Engineers used HCB on a bridge in Kentucky. The IDEA inventor has signed licensing agreements with companies in the European Union, Russia, Kuwait, and Brazil. AASHTO's Technology Implementation Group selected HCB as a focus technology for implementation in 2011.



Figure 1

Hybrid composite beam being installed on High Road Bridge in Lockport Township, Illinois.

THE PAVEMENT THICKNESS DENSITY METER

NCHRP-IDEA Project 61

Kenneth R. Maser [Tel.: (781) 648-0440, Fax: (781) 648-1778]
INFRASENSE Inc., Arlington, Massachusetts

This project developed and tested an automated portable device, using a low-power-pulsed electromagnetic wave detection technique, for determining asphalt pavement thickness and density during construction. The work involved antenna evaluation, software development, field data analysis, system specifications, and prototype development. Three different antenna configurations were evaluated, and based on performance data, a horn antenna was selected. Field data on a newly paved road section was collected to further test the antenna configurations, evaluate potential thickness accuracy, and to provide a data set for software development. A real-time prototype software was developed and tested on the field data. The antenna system was further improved with respect to electronic performance and packaging. Laboratory and field tests show that the device with the new horn antenna can accurately determine the dielectric constant of asphalt and can provide pavement thickness accuracy to within 0.2 inch. The test results also show a correlation of asphalt dielectric constant with its air content.

The PTDM will enable agencies to maximize pavement life and minimize life cycle costs by accurately and completely determining, at the time of construction, if pavement has been built according to specifications. With this capability, agencies will be able to save millions of dollars in premature, unplanned, and unnecessary repairs, and rehabilitation caused by inadequately constructed pavement. The final report is available from the National Technical Information Service (NTIS # PB2003-100546).



Figure 1

Portable PTDM.

A NEW TECHNIQUE FOR CHARACTERIZING PAVEMENT SURFACE PROFILES AND TEXTURES

NCHRP-IDEA Project 62

Cam Nguyen [Tel.: (979) 845-7469, Fax: (979) 845-6259] and Tom Scullion
Texas A&M University, College Station, Texas

This project investigated developing a high-resolution millimeter sensor and demonstrating its use in real-time measurements of transverse and longitudinal profiles and micro/macro textures of pavements. A millimeter-wave sensor prototype (Figure 1) was designed, integrated, and tested. The compact and low-cost sensor was completely realized using millimeter-wave integrated circuits. Laboratory tests provided promising results on the feasibility of the system in mapping surface profiles. In one test, the prototype measured the surface profiles of a metal foil deposited on top of a foam block. The measured contour resembled very closely the shape of the actual sample. In another test, the sensor system imaged several tiles placed next to each other at different heights. Again, the sensor produced a profile closely resembling the actual surface.

The results indicate that the system can map surface profiles with sub-millimeter resolution. The prototype is ready for laboratory and field evaluations to measure macro and micro textures of pavement. However, a redesign of the sensor and a new horn antenna should further improve the performance of the system. The final report is available from the National Technical Information Service (NTIS # PB2002-103443).

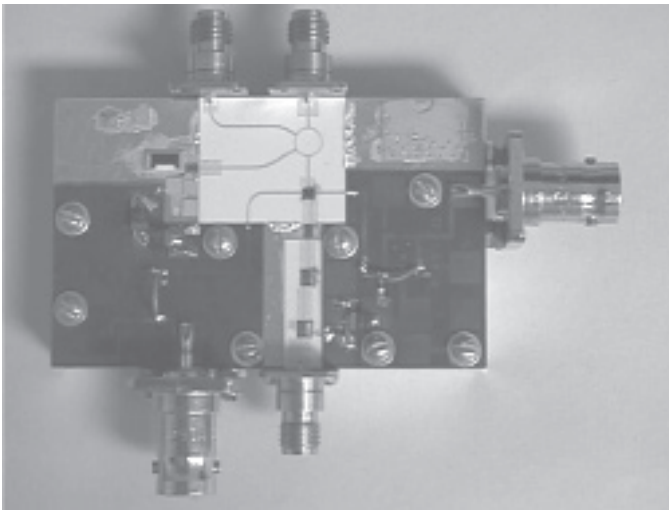

Figure 1

The millimeter-wave sensor prototype.

MANUFACTURE AND TESTING OF A FILAMENT WOUND COMPOSITE BRIDGE SUPERSTRUCTURE

NCHRP-IDEA Project 63

Dennis Parsons [Tel.: (217) 333-2690, Fax: (217) 333-9464] and Scott White
University of Illinois, Urbana-Champaign, Illinois

The project investigated the manufacturability and structural performance of filament-wound, fiber-reinforced plastic composite bridge structures (Figure 1). The bridge structure consists of two components: a series of inner cells, lying parallel to the direction of traffic, and an outer shell. Following preliminary specimen calculations and the mandrel and fixture designs, finite element analyses were conducted to determine the physical dimensions of the prototype bridge superstructure. Specifications and geometry of the prototype were finalized and designs for the inner cell mandrel and fixtures needed to wind the outer shell and test on the bridge superstructure were completed. Laboratory tests were performed to determine the accuracy of finite element models with promising results. Tests were then performed on three model bridges. Results indicate that the finite element models provide good predictions of the stiffness and strength of the models. These finite element models were refined by incorporating the results of material tests. The findings of this project need to be further verified with full-scale, actual size bridges in the field. The final report is available from the National Technical Information Service (NTIS # PB2002-104355).

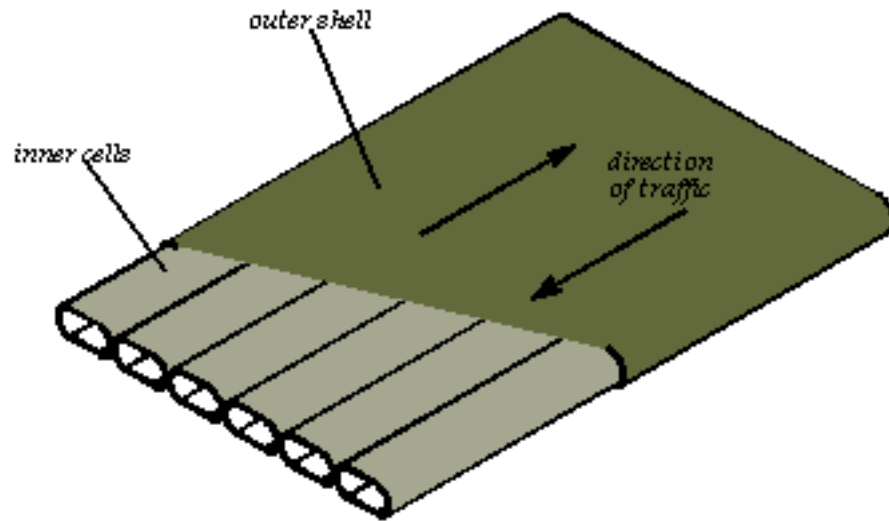

Figure 1

Bridge structural system.

QUANTITATIVE CHARACTERIZATION OF ASPHALT CONCRETES USING HIGH-RESOLUTION X-RAY COMPUTED TOMOGRAPHY (CT)

NCHRP-IDEA Project 64

Richard A. Ketcham [Tel.: (512) 471-0260, Fax: (512) 471-9425] and William D. Carlson
University of Texas, Austin, Texas

The project develops an asphalt pavement evaluation methodology based on high-resolution X-ray computer tomography (CT) to obtain three-dimensional imagery of asphalt concrete. The thrust of the project was to develop a software application called “Blob3D” which utilizes industrial high-resolution X-ray computed tomography data to provide quantitative, nondestructive evaluation of asphalt concrete pavements (Figure 1). The project accomplished the initial conception, design, and development of the software program to obtain the required analysis. During the first phase, the program architecture was laid out and the data analysis was divided into three stages: segregation, separation, and extraction. Software to accomplish each of these tasks was developed in parallel and successively improved and tested to achieve a working package. Once a CT data volume has been segmented and separated, it can be mined to get the desired data. The data that can be extracted from the system includes particle (or void) volume, center of mass, surface area, aspect ratio, long axis orientation, and location, direction, and surface area of all particle-particle contacts. A series of controlled tests was performed to verify that the information produced by the analysis was correct. In all cases, the test results met expectations.

The techniques developed in this project can aid in the formulation of mixing methods by comparing experimentally mixed cores; poor-performing mix designs can be identified and eliminated. Such an analysis can also be used as a forensic tool to investigate pavement failures. These investigations should allow for the building of higher-quality and more durable pavements, with large indirect savings from reduced need for maintenance and replacement. Five hundred million tons of asphalt concrete is laid down each year as overlays, full-depth pavements, and other applications, at a cost of up to \$15 billion. Any incremental savings enabled by improved pavement design should result in considerable savings. Reduced wear on vehicles due to better pavements also constitutes an indirect but potentially large payoff. The final report is available from the National Technical Information Service (NTIS # PB2001-102198).

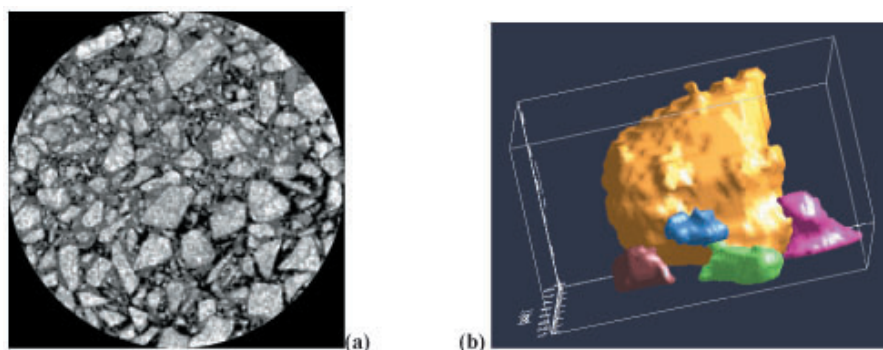

Figure 1

(a) Example CT scan of an asphalt concrete core. Field of view is 145 mm. (b) Sample Blob3D program view showing 3D processing to extract aggregates from scan data.

APPLICATION OF SHAPE MEMORY ALLOYS IN SEISMIC REHABILITATION OF BRIDGES

NCHRP-IDEA Project 65

Reginald DesRoches [Tel.: (404) 385-082, Fax: (404) 894-0211]

Georgia Institute of Technology, Atlanta, Georgia

This project demonstrated the feasibility of using shape memory alloy (SMA) devices (restrainer cable and core elastomeric bearings) for seismic rehabilitation of highway bridges (Figure 1). By concentrating energy dissipation in controlled locations, these devices can be used to limit the relative hinge displacement and reduce the demand on individual frames in typical bridges. The research evaluated the characteristics of nickel-titanium shape memory alloy rods and wires under compression-tension cycles as a function of diameter size, loading frequency and temperature in order to establish their suitability for bridge rehabilitation. SMA restrainer bars, one inch in diameter, were subjected to uniaxial tension, in full-scale tests. The bars were also subjected to cyclical strains up to 8 percent with minimum residual deformation. The effectiveness of SMA restrainer bars in bridges was further evaluated by an analytical study of a simply supported multi-span bridge. The relative hinge displacement in a bridge was compared for retrofits for conventional steel restrainer cables and SMA restrainer bars. The comparison showed that the SMA restrainers reduced the relative hinge displacements at the abutment much more effectively than conventional steel cable restrainers. In addition the superelastic properties of the SMA restrainers resulted in energy dissipation at the hinges. Finally, the evaluation of the multi-span, simply-supported bridge subjected to near-field ground motion showed that the SMA bars were very effective in limiting the response of bridge decks to near-field ground motion. The increased stiffness of SMA restrainers at large strains provided additional restraint to limit the relative openings in a bridge.

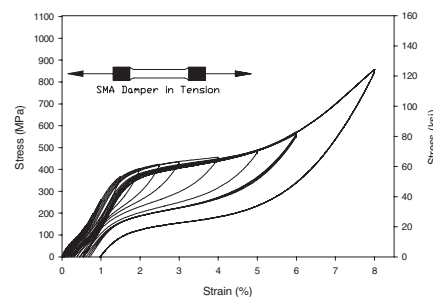

Figure 1

(left) Proposed SMA damper, and (right) Stress-strain relationship for nitinol shape memory alloy damper.

There are thousands of bridges in the United States that are in need of seismic retrofit. Should this technology prove effective and cost efficient, it can become a widely used seismic retrofit technology. Collaboration with Shape Memory Alloy manufacturers and end-users is essential to ensure the transfer of the research results to practice. The final report is available from the National Technical Information Service (NTIS # PB2002-103441).

DEVELOPMENT OF AN INNOVATIVE CONNECTOR SYSTEM FOR FIBER-REINFORCED POLYMER BRIDGE DECKS TO STEEL STRINGERS

NCHRP-IDEA Project 66

Julio F. Davalos [Tel.: (304) 293-3031, ext. 2632, Fax: (304) 293-7109] and Karl E. Barth
West Virginia University, Morgantown, West Virginia, and

Pizhong Qiao

The University of Akron, Akron, Ohio

This project developed and tested a connector system (Figures 1 and 2) for attaching fiber-reinforced polymer (FRP) bridge decks to support steel stringers. The connector dimensions were defined through finite element analyses. The connector design was experimentally evaluated first, by, testing a single connector between a section of the FRP deck and a steel wide-flange beam. The ultimate strength of the connector was obtained, and the loads-slip response was defined along with an evaluation of the failure modes. The results were used to redesign the connector and make it simpler and more economical. The performance of the connector-stringer design was evaluated for a number of loads to establish the required number of connectors for adequate deck restraint, percent of composite action, and effective flange width for a deck/stringer system. The contractor worked with West Virginia and Kansas DOTs to implement this concept in their bridge projects. The final report is available from the National Technical Information Service (NTIS # PB2004-100134).



Figure 1

Photo of steel-sleeve connector.

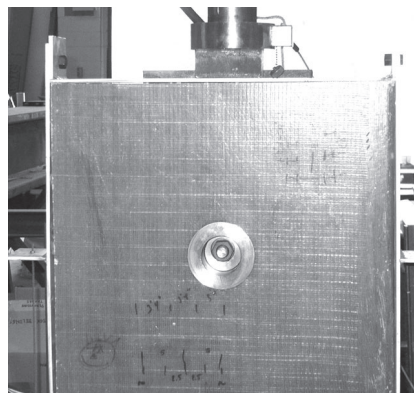

Figure 2

Photo of FRP panel and connector.

ALL COMPOSITE BRIDGE SIDEWALK

NCHRP-IDEA Project 67

D. Thomson [Tel.: (781) 622-5505, Fax: (781) 890-0488] and T. Campbell
Foster-Miller Inc., Waltham, Massachusetts, and

G. E. Johansen
E.T. Techtonics Inc., Philadelphia, Pennsylvania

This project developed and tested a lightweight cantilevered, fiber-reinforced composite sidewalk for roadway bridges (Figure 1). Work performed in collaboration with the Vermont Agency of Transportation (VAOT) defined performance specifications for the sidewalk with reference to material and mechanical properties for bridge application, including specific strength and deflection requirements for cantilevered sidewalk system design. The system has a single molded component for cantilevered support. The cantilevered support, which consists of carbon fabric and epoxy resin, is a constant cross section I-beam with an overall height of 18 in. and weighs approximately 125 lb. The length of the cantilevered support is 11 ft and the width of the walkway portion of the sidewalk system is 6 ft. The flange width, flange thickness, and web thickness are 12.75, 0.5, and 0.25 in. respectively. The composite sidewalk system was sized for a minimum factor of safety (FS) of 3. Validation of design was performed through the use of static and creep tests at the University of New Hampshire. The composite I-beam developed in this project was displayed at the Smithsonian Cooper-Hewitt National Design Museum's exhibit, Extreme Textiles: Designing for High Performance, in New York in 2005. The final report is available from the National Technical Information Service (NTIS # PB2002-1000006).



427-P-98595-7

Figure 1

E. T. Techtonics composite pedestrian bridge.

GEOCOMPOSITE CAPILLARY BARRIER DRAIN FOR LIMITING MOISTURE CHANGES IN PAVEMENT SUBGRADES AND BASE COURSES

NCHRP-IDEA Project 68

John Stormont [Tel.: (505) 277-6063, Fax: (505) 277-1988]
University of New Mexico, Albuquerque, New Mexico, and

Karen Henry
US Army Cold Regions and Research Engineering Laboratory
Hanover, New Hampshire

This project developed and evaluated the effectiveness of a geocomposite capillary barrier drain (GCBD) system (Figure 1) in preventing pavement damage by controlling moisture movement in pavement subgrade and base course. A number of geotextiles were evaluated for their suitability as a transport layer using a series of tests that included capillary rise, moisture retention, function measurements, siphoning, and transmissivity under suction. At infiltration rates that occur in the field, the GCBD drained water from overlying base material that was not saturated. Furthermore, the GCBD prevented the moistening of the subgrade at many of the filtration rates tested. This allows the design of unsaturated soil drainage to help extend pavement life by limiting the time the bases are saturated and by diverting large volumes of water to a drainage system before it reaches the subgrade. In the specific GCBD tested, water drained from overlying base soil when subjected to suction head of 100 mm and greater. Furthermore, at long term infiltration rates of 0.1 to 0.15 mm/hr, the GCBD prevented infiltrating water from reaching the subgrade. Finally, the GCBD recovered its function and protected the subgrade following a test in which a small amount of water had broken through the GCBD into the subgrade. Further development is needed before the technology can be implemented and before a transport layer—more economical than the one tested in this project—would make GCBD more affordable and implementable. The project was highlighted in a recent issue of *Progressive Engineer*, an on-line engineering magazine and information source. The final report is available from the National Technical Information Service (NTIS # PB2003-101349).

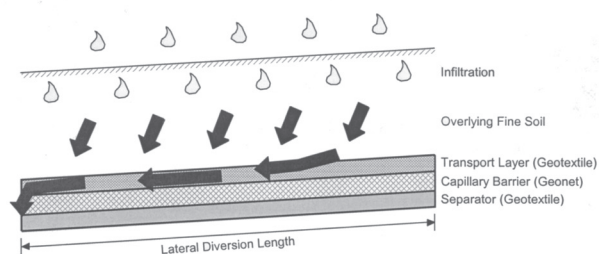

Figure 1

Geocomposite capillary barrier drain.

DEVELOPMENT OF A CONDUCTIVITY SPECTRUM PROBE (CSP) FOR PREDICTING CHLORIDE PERMEABILITY IN CONCRETE

NCHRP-IDEA Project 69

Kenneth R. Maser [Tel.: (781) 648-0440, Fax: (781) 648-1778]
INFRASENSE Inc., Arlington, Massachusetts

This project developed and tested a portable conductivity spectrum probe (CSP), for in situ determination of chloride permeability of concrete (Figure 1). Laboratory equipment for conductivity and dielectric measurements was assembled and calibrated with known reference materials. A number of concrete specimens, covering a range of mix design parameters and chloride concentrations, were prepared and characterized for chloride contents using standard methods. Following a preliminary testing of these specimens, the CSP was tested on a number of additional well-characterized samples obtained from the W.R. Grace laboratories in Cambridge, Massachusetts, that covered a range of concrete mix formulations, rebar configurations, and chloride exposures. The tested samples were soaked in water for six days and retested in saturated state followed by testing in a partially dried state. The test data were correlated with chloride permeability that was determined independently using standard test methods. Known relationships between conductivity and chloride permeability were used to establish a functional form for relating the measured CSP data to the chloride permeability data. Additional development and refinement of the equipment is needed for its field application and implementation. The final report is available from the National Technical Information Service (NTIS # PB2003-102867).

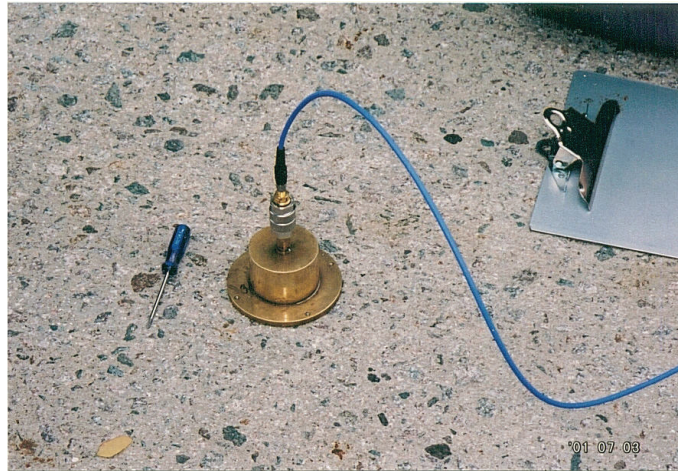

Figure 1

CSP probe.

FLAMESPRAY COATING AS AN ENVIRONMENTALLY ACCEPTABLE PAVEMENT MARKING TECHNIQUE

NCHRP-IDEA Project 70

Anthony L. Andradý [Tel.: (919) 541 6713, Fax (919) 541 8868]

Chemistry and Life Sciences, Research Triangle Institute, Durham, North Carolina

This project tested an environmentally safe flamespray coating technique using new polymer formulations for pavement marking. Initial investigations of commercially available alkyd thermoplastic resins suggested their suitability for flamespray applications. However, the resins contained premixed glass beads that made them unsuitable for flame spray applications. Also, the resin particle size was found to be too large to allow a uniform flame spraying. These problems were addressed by custom blending the alkyd resin without glass beads, melt extruding, and cryogenic grinding to reduce particle size. However, the process produced very fine dust-like particles and the nonresin components in the mix tended to separate when the material was fluidized. Two new formulations with different levels of solid plasticizer in base resin were compounded via extrusion followed by cryogenic grinding to reduce the particle size of the product. These formulations, which, could be flamesprayed onto concrete substrates showed good adhesion and abrasion resistance. The approach appears feasible but will require modification of the spray gun to obtain better edge definition. Also, the glass beads will have to be used as a "drop on" application immediately following the resin spraying. Further work is necessary to optimize the resin formulations and to evaluate their long-term weather durability. The final report is available from the National Technical Information Service (NTIS # PB2003-102865).

IMPLEMENTATION OF TUNED DAMPERS FOR SUPPRESSION OF BRIDGE STAY CABLE VIBRATIONS

NCHRP-IDEA Project 71

Armin B. Mehrabi [Tel.: (847) 965-7500, Fax: (847) 965-8997]
Construction Technology Laboratories Inc., Skokie, Illinois

Habib Tabatabai
University of Wisconsin, Milwaukee, Wisconsin

Niket M. Telang
Construction Technology Laboratories Inc.

This project was a follow-on activity for an earlier IDEA project (NCHRP-50) to demonstrate the effectiveness of tuned mass dampers (TMD) in minimizing stay cable vibrations in a full-scale field trial on an actual highway bridge. Several visco-elastic materials and model configurations were investigated to identify models that could be considered for full-scale prototype adaptation. Simultaneous to experimenting with various models, analytical investigations were conducted to calculate required properties and dimensions of the full-scale versions of the models. The analytical evaluation identified a problem in adapting the scaled models to full-scale sizes due to low-frequency vibrations of the actual bridge stay cables. This problem was addressed by using a hybrid of impact and tuned damper. Laboratory tests, conducted on model cables using two types of tuned impact dampers (TID), showed the TID to be more effective than the TMD. The TID was also found to be effective at low frequencies. Using the evaluation results, a full-scale refined TID system was designed and fabricated. The prototype system was installed on experimental basis on the Talmadge Bridge in Savannah, Georgia. The field test results confirmed the efficiency and applicability of the TID system for increasing the cable apparent damping ratios and suppression of excessive vibrations. The final report is available from the National Technical Information Service (NTIS # PB2003-102863).

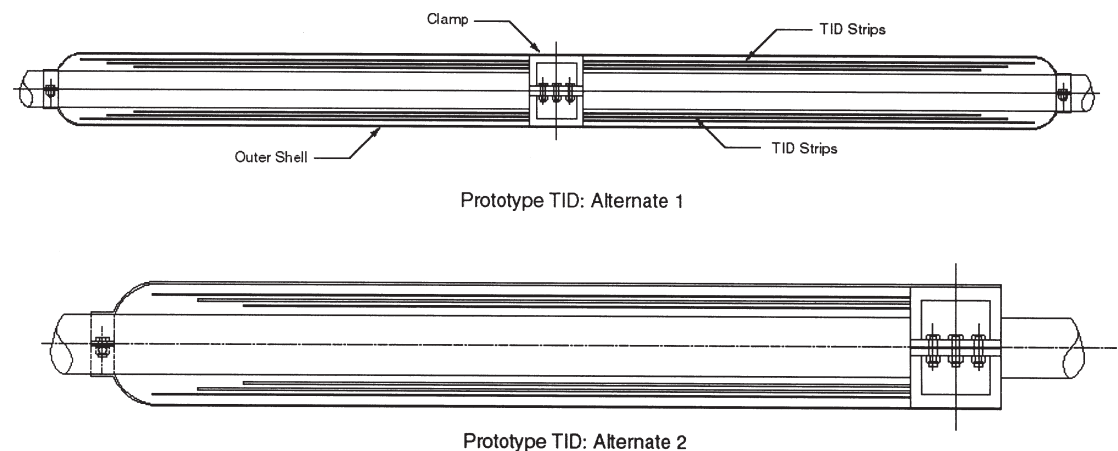

Figure 1

Tuned Induced Damper (TID) system.

IMPROVED FILTRATION OF WASH WATER GENERATED DURING BRIDGE MAINTENANCE PAINTING

NCHRP-IDEA Project 72

Robert Lewallyn [Tel.: (404) 894-0281, Fax: (404) 894-2481]
Georgia Tech Research Institute, Atlanta, Georgia, and

Theodore Hopwood

Kentucky Transportation Center, University of Kentucky, Lexington, Kentucky

This project designed and tested a filtration system (Figure 1) for removing both particulate and soluble lead from wash water generated by pressure washing lead-based paint from highway bridges during painting operations. The filtration system relies on a granular compound capable of chemically binding free lead into an insoluble lead mineral. A literature search identified several commercial hydroxypyromorphite compounds suitable for binding lead in an aqueous environment along with many apatite minerals that appeared to stabilize lead. Bench-scale testing of three commercial filter media containing lead-stabilizing compounds, based on aluminum silicate and calcium phosphate, were conducted under simulated field conditions.

All three systems performed adequately in removing both total and dissolved lead from the synthetic effluent. Based on test results and cost considerations, LeadX was selected as the primary medium for lead removal. A full-scale prototype filtration system capable of handling 400 gallons of water per hour was designed and fabricated. It consisted of a flow equalization tank followed by a trickling sand filter (to remove large particulates) and an upflow filter column containing the filter medium. The prototype was tested on two bridge washing projects at two locations in Kentucky. In both instances, the filtration system proved effective in removing lead from the washwater. The total lead concentrations were reduced to 20 ppb or less from 10 ppm. The final report is available from the National Technical Information Service (NTIS # PB2003-102869).



Figure 1

Wash water filtration system.

DEVELOPMENT OF A SCREED TO DETECT AND MEASURE SEGREGATION OF HMA PAVEMENTS

NCHRP-IDEA Project 73

Mary Stroup-Gardiner [Tel.: (334) 844-6280, Fax: (334) 844-6290]
Auburn University, Auburn, Alabama

This project developed and tested an infrared sensor-based screed attachment for asphalt paving equipment to monitor temperature differentials as a method for detecting and measuring segregation during construction. The prototype system consists of a transverse line of infrared sensors, signal conditioners, computer data acquisition system, and a global positioning system (GPS). The system is capable of continuously monitoring temperature differentials during construction. Real time transverse temperatures are plotted on a computer screen for use by the paving crew. The software produces a summary of potentially segregated areas by level of segregation (i.e. low, medium, and high) as well as the number of paver stops over one minute for use by the state agency. Preliminary testing with the system on existing pavement surfaces shows that the system can adequately evaluate the transverse temperature differential (Figure 1). The low-budget GPS system is found to be reasonably accurate over multiple runs for locating pavement anomalies. The software is easy to use and automatically prepares a report that locates all nonuniform transverse temperature areas. The final report is available from the National Technical Information Service (NTIS # PB2003-102864).

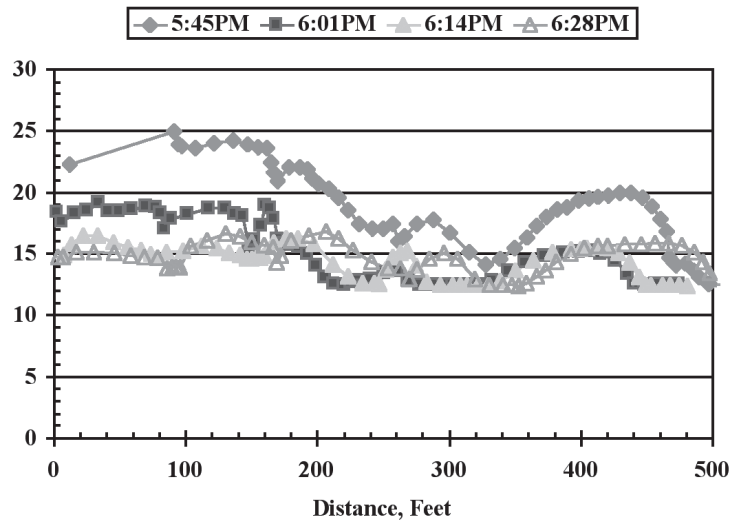

Figure 1

Temperature ranges for four runs on an existing pavement.

ADHESION TOOL FOR OVERCOATING RISK-REDUCTION ANALYSIS

NCHRP-IDEA Project 74

Moavin Islam [Tel.: (703) 679-9220, Fax: (703) 679-9220]

Corrpro Companies Inc., Chantilly, Virginia, and

James A. Ellor

Corrpro Companies Inc., Arlington, Virginia

This project's goal was to develop a new coating adhesion test that is based on induced stress to determine the suitability for overcoating of an existing highway structure. Laboratory test procedures for measuring coating stresses were explored that included deflection measurements using a capacitive sensor and direct measurements using a miniature surface, mounted fiber-optic strain gage. Based on test results, the direct measurement method using miniature strain gages was selected since it provided more reliable and reproducible data than the deflection measurement test. Two types of prototype testers were then fabricated for laboratory and field evaluation: prestressed elastic material adhesion tester and the mechanical shear stress adhesion tester. The tests were performed on a number of overcoating materials that included a polysilicone enamel, an acrylic, a moisture-cured urethane, and two different epoxies. The results showed the elastomeric device to be most promising for adhesion testing. It maintained a near constant level of stress on test panels throughout the monitoring period and appeared to be most suitable for time-dependent failure evaluation. The present device, however, is not capable of producing 10 MPa stresses over test panels representative of an existing structure and needs further refinement and evaluation in order to make it into a field tester for coating adhesion. The final report is available from the National Technical Information Service (NTIS # PB2003-102866).

AUTOMATED MOBILE HIGHWAY SIGN RETROREFLECTIVITY MEASUREMENT

NCHRP-IDEA Project 75

Norbert H. Maerz [Tel.: (573) 341-6714, Fax: (573) 341-4368]
University of Missouri, Rolla, Missouri

This project developed and tested a prototype digital video image analysis system (Figure 1) to measure highway sign retroreflectivity. A literature review was conducted to obtain additional relevant information on highway sign retroreflectivity. The image processing hardware was procured and checked. An image-processing algorithm to perform real time analysis was developed. Signs were obtained from the Missouri DOT to calibrate the system. An outdoor measuring range with interchangeable sign mounted on a signpost was set up for experimental development. Following laboratory and outdoor evaluations, a prototype system to measure highway sign reflectivity was developed and tested under highway conditions. The results show the feasibility of developing a mobile vision-based system to classify and measure the visibility of road signs. The results also showed a rather poor correlation between retroreflectivity and visibility. Retroreflectivity was found to be a poor predictor of the visibility of white, yellow and—to a lesser extent—orange signs. It is, however, a relatively good predictor of the visibility of red and—to a lesser extent—of green and blue signs. Brown signs were found to be of low retroreflectivity and visibility. The method developed in this project is the closest possible analog to what the eye sees when looking at signs under the normal illumination provided by the headlights. The method should be used at night and may be limited to use with high beams. The final report is available from the National Technical Information Service (NTIS # PB2003-102868).



Figure 1

Imaging equipment mounted in a vehicle.

STABILIZATION OF LANDSLIDES USING HORIZONTAL WICK DRAINS

NCHRP-IDEA Project 76

Paul M.Santi [Tel.: (303) 273-3108, Fax: (303) 273-3859]
Colorado School of Mines, Golden, Colorado, and

C. Dale Elifrits
University of Missouri, Rolla, Missouri

This project was a follow-on activity of an earlier IDEA project (NCHRP-57) for field testing and implementing the horizontal wick drains technology for stabilizing landslides. Work in this follow-on project involved installing and evaluating new field sites and completing the monitoring of the field sites stabilized with horizontal wick drains that had been previously installed in the NCHRP-57 project. The work also addressed technical and economic issues related to the clogging of the drains. In total, more than 170 drains totaling over 8,600 feet in length were installed in eight sites in Missouri, Colorado, and Indiana. The drain installation rates averaged over 60 feet per day for cost estimated at approximately \$2.50 per foot. Laboratory experiments conducted over a period of two years to assess the potential clogging of wick drains showed varying amounts of fine particles coating the inside strands of the drain fabric. However, the drain's ability to transmit water was not affected. Finally, a procedure was developed to estimate the shape of the water table surface for drained landslides, using parameters easily measured in the field and laboratory. The wick drain technology to stabilize landslides is now available for implementation. The final report is available from the National Technical Information Service (NTIS # PB2003-102861).



Figure 1

Completed set of drains near Boonville, Missouri. Water flow out of center drain is being measured.

THE DEVELOPMENT OF A COMPUTER CONTROLLED IMAGE ANALYSIS SYSTEM FOR MEASURING AGGREGATE SHAPE PROPERTIES

NCHRP-IDEA Project 77

Eyad Masad [Tel.: (509) 335-9147, Fax: (509) 335-7632] and Tom Papagiannakis
Washington State University, Pullman, Washington

This project developed and tested an automated image analysis system (AIMS) for measuring aggregate shape characteristics (Figure 1). The work involved development of both software and hardware systems. The software incorporated several image analysis procedures and its application to measure the texture of a wide range of fine and coarse aggregates. The hardware for the image analysis system incorporated a computer-controlled mechanism to allow capturing different projections of aggregate particles and describing their shape properties rapidly and accurately. Further software refinement produced a user-friendly version of the original software that facilitated data presentation and manipulation. The hardware and software were then integrated to produce a prototype of the automated aggregate analysis system. The system was tested on a range of fine and coarse aggregates and the results were compared with hot mix asphalt performance data. The image analysis procedure provided detailed information on shape properties of aggregates in a relatively short time. The shape measurements also showed a good correlation with the resistance of asphalt mixes to permanent deformation measured in the laboratory using different wheel tracking devices. AIMS was further evaluated and refined with support from FHWA's Highways for LIFE Program. The system is now commercially available and is being used by FHWA in its mobile laboratory for demonstration and training. Two test procedures based on AIMS have been adopted by AASHTO for determining aggregate shape properties (TP 81 and PP 64). (NTIS Report # PB2003-102870).

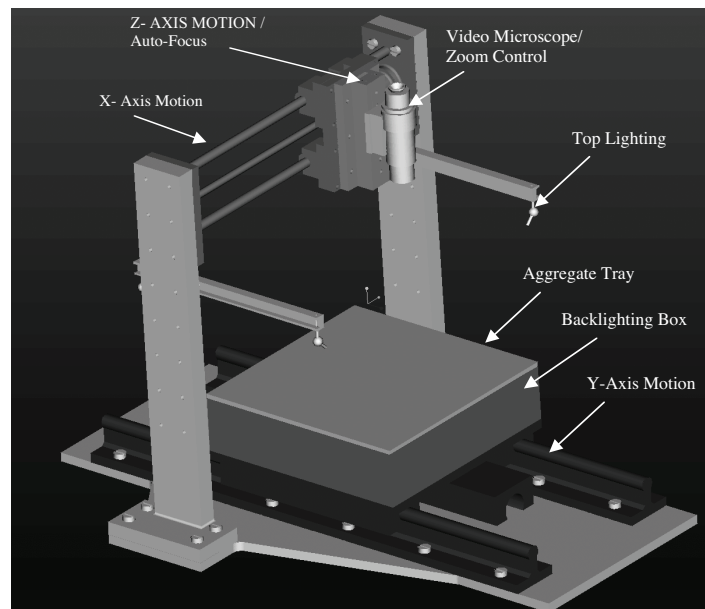

Figure 1

3-D graphical model of AIMS.

AGGREGATE SHAPE CHARACTERIZATION USING DIGITAL IMAGE PROCESSING

NCHRP-IDEA Project 78

Norbert H. Maerz [Tel.: (573) 341-6714, Fax: (573) 341-4368] and David N. Richardson,
University of Missouri, Rolla, Missouri

This project developed and tested a rapid method based on automated digital imaging technology to characterize aggregate shapes. A prototype automated imager analyzer (Figure 1) was developed and evaluated. Over 150 aggregate samples procured from the Missouri DOT and a private quarry were used for evaluation. The imaging hardware was modified to use backlighting to reduce errors from dark aggregates and upgraded to allow rapid and accurate measurements. The software was also modified to enable particle angularity measurements in terms of curve radius. Control samples of various configurations with known or uniform characteristics were prepared and tested. Image-measured flat and elongation ratios were found to be fairly close to matching caliper results, and the repeatability of measurements was found to be better than with manual tests. Results also show that image-measured angularity can be correlated with void tests. Analysis of flat and elongation measurements as a function of crusher type showed that impact type crushers tended to produce more cubical particles even when rock type is not accounted for. The equipment needs additional development, refinement, and testing for its implementation. The final report is available from the National Technical Information Service (NTIS # PB2004-105016).



Figure 1

New flat and elongated image analyzer.

CONCRETE ROAD RECYCLER—HAMMER-ANVIL TEST RIG

NCHRP-IDEA Project 79

Deems Pfaff [Tel.: (970) 476-6577, Fax: (970) 476-0504]

Road Processing Resources, Inc., Vail, Colorado, and

Robert Burggren [Tel.: (651) 388-6179, Fax: (651) 388-6179]

Red Wing, Minnesota

This project involves designing, building, and demonstrating the practical feasibility of a mechanical system based on the anvil-hammer concept for removing, fragmenting, and recycling concrete pavement. Figure 1 shows the schematic diagram of the system. The designs of the hammer, anvil, feed system, and other components of the prototype system were developed and evaluated and various technical and operational issues were identified and resolved. A trailer test rig was fabricated for mounting and using the prototype road recycler system. The prototype system was integrated and mounted on the trailer at a test facility in Iowa. The present set-up uses a gravity-drop hammer but can be adapted to pneumatic hammers. The tests to-date show a capacity to separate concrete from steel to satisfy useable and saleable scrap. The aggregate composition will require more testing with feed bite, hammer stroke, and hammer face variables to suit the nature of the material being processed. After in-house tests, the system will be further improved and demonstrated in the field on actual pavement slabs. The contractor is working with several heavy equipment manufacturers in the design and assembly of the final prototype system. Kansas and Iowa DOTs have collaborated in testing of the prototype system.

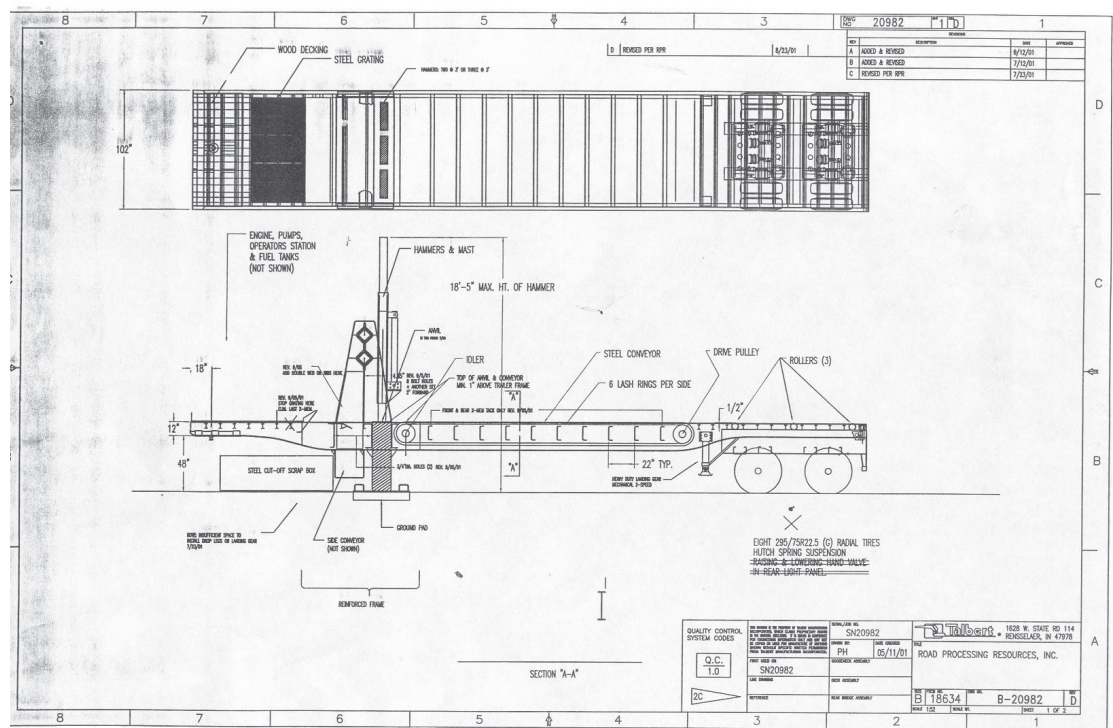

Figure 1
Schematic diagram of road recycling machine.

DEVELOPMENT OF A GENERIC CONNECTOR SYSTEM FOR ATTACHING CONVENTIONAL BRIDGE RAILS TO FIBER-REINFORCED POLYMER COMPOSITE BRIDGE DECKS

NCHRP-IDEA Project 80

Jerry D. Plunkett [Tel.: (303) 773-7790, Fax: (303) 733-2901, Email: <vrlp@earthlink.net>],
Kansas Structural Composites Inc., Russell, Kansas

This project developed and tested a generic attachment system that permits the use of standard steel railings and posts on commercial fiber-reinforced polymer (FRP) composite bridge decks. Following analysis and connector design for both steel bridge railings and concrete barriers, static tests were performed that indicated a high probability of the connector system successfully passing the mandatory crash test. Based on test results, a multi-bolt design for the plate system was developed. In static tests using 12-bolt plate, the post failed in plastic bending, but no damage occurred to the deck and no serious strain in the area of the connector plates. In tests using 6-bolt plate, the railing post failed similarly, and there was some strain on the deck. Tests with a concrete barrier connected to the deck with 6 bolts showed no strain and no failure in the deck panel. The project achieved its goal of developing and testing a connector system that allows the attachment of standard steel post and rail, as well as standard concrete barrier systems, to most currently manufactured FRP composite bridge decks and superstructures. Two bridges with FRP superstructures in the states of Missouri and New York were built. Both successfully passed the required TL-2 static test and have been performing satisfactorily with no evidence of any failure or any serious loading in the superstructure. The project team also installed bridge decks for two detour bridges in Kansas in 2004 that continue to perform satisfactorily.

AUTOMATED REAL-TIME PAVEMENT CRACK DETECTION AND CLASSIFICATION SYSTEM

NCHRP-IDEA Project 81

Heng-Da Cheng [Tel.: (435) 797-2054,
Fax: (435) 797-3265]
Utah State University, Logan, Utah, and

Chris Glazier [Tel.: (801) 965-4551],
Utah Department of Transportation,
Salt Lake City, Utah

This project developed an automated real-time crack detection and analysis system based on image processing and computer vision techniques. The system consists of a personal computer, a frame grabber with two on-board processors, a distance sensor and a video camera mounted on top of a van. The images from the video camera are captured and converted to digital images by the frame grabber, while the images are recorded by the video camera for future reference. Over 20,000 images were obtained under different vehicle speeds and light conditions and digitized. Processing algorithms were developed and applied to the collected images. The effectiveness and speed of the algorithms were improved for features such as segmentation, enhancement, noise removal, Hugh transformation and morphology, and so forth for crack detection and classification applications. Three evaluation criteria were used: performance for different pavement types, including cracks, sealed cracks and shadows, performance under different light conditions and circumstances, and performance when there are some tars (bleeding) or other non-crack scenes on the images. Pavement images were obtained with vehicle speeds of 35 mph to 75 mph under different lighting conditions, including both cloudy and sunny days. The results demonstrate that the proposed system can accurately process the images of different types of pavements and under different lighting conditions, including the shadows (Figures 1 and 2). The final report is available from the National Technical Information Service (NTIS # PB2003-101350).

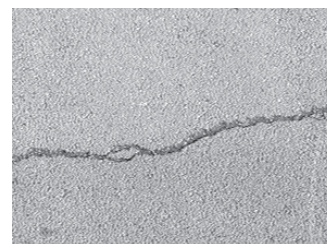

(a)

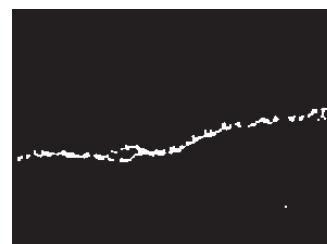

(b)

Figure 1

(a) The original image with a transverse crack. (b) The resulting image.

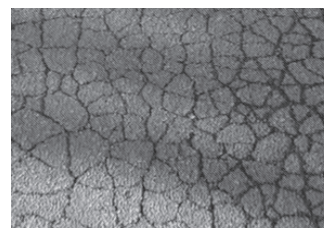

(a)

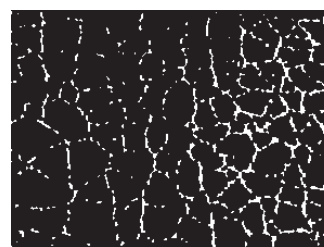

(b)

Figure 2

(a) The original image with an alligator crack. (b) The resulting image.

DEVELOPMENT AND FIELD VERIFICATION OF TORSIONAL CYLINDRICAL IMPULSE SHEAR TEST

NCHRP-IDEA Project 82

Wanda Henke [Tel.: (410) 252-4474, Fax: (410) 252-4474] and Robert Henke
Dynamic In Situ Geotechnical Testing Inc. Lutherville, Maryland

This project developed and tested an in situ torsional cylindrical impulse shear test for shearing deformation characteristics for geotechnical earthquake engineering analysis applications (Figure 1). The work involved rebuilding and improving an existing FHWA impulse shear testing system. All main components of the FHWA probe were assembled or reassembled and bench tested. These components included the testing module, the hydraulic module (containing a new sensing system for measuring the advance of the probe cylinder into the test soil), and a newly devised axial load cell. The bench tests indicated satisfactory performance of all the components and equipment. The components of the accessory equipment were also repaired, reassembled and bench tested. These components included a manually operated simple probe bed, a hydraulic pump, an electric generator, and a hydraulic system control panel. Bench tests indicated satisfactory performance of each of the components. Work is now underway on the consolidation of the data acquisition and control systems. This IDEA project was being complemented by a FHWA/State DOT-sponsored pooled-fund study for further development and implementation of the impulse shear test. The final report is available from the National Technical Information Service (NTIS # PB2004-100132).

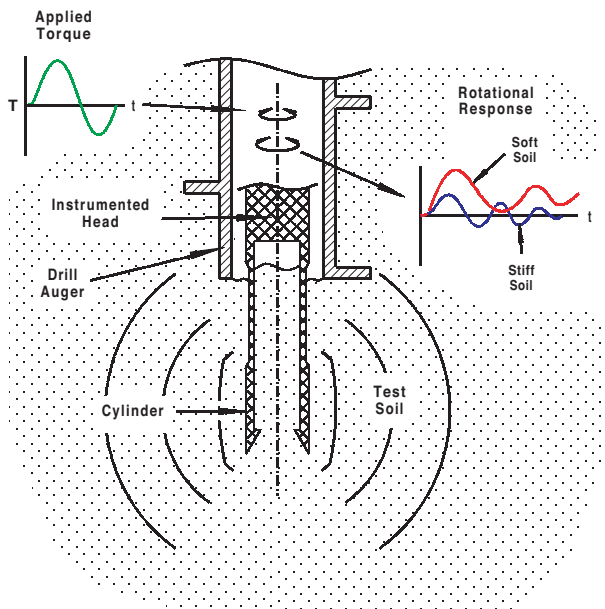

Figure 1

Basic idea of impulse shear test.

TESTING OF A WIDE AREA OPTICAL SURFACE CONTAMINATION DETECTION SYSTEM FOR PUBLIC TRANSPORTATION APPLICATIONS

NCHRP-IDEA Project 83

Paul Schmokel [Tel.: (952) 892-4888, Fax: (952) 892-4430]

Sensor Systems, Goodrich Corporation, Burnsville, Minnesota

This project developed a laser-based remote sensing technology for detecting ice on road surfaces. The system is an adaptation of a wide area ice detection system (IceHawk) that utilizes laser polarization properties and has been applied successfully to detect ice on typical aircraft surfaces (Figure 1). The work involved analysis of target materials, improvement of range performance, and detection of wet surfaces. The existing IceHawk system was modified to allow for stationary mount and remote operation. Target materials (concrete, asphalt, etc.) were evaluated for polarization reflection behavior, and test data collected during winter was used to improve and refine the system. A station pole-mounted IceHawk system was found adaptable to detect ice and snow on roadway surfaces. Test results showed a distinguishable difference between a clean surface and one covered with snow or ice. Data to determine the minimum thickness threshold settings for ice, snow, and wet roadway conditions was collected and a pixel-filtering technique was evaluated to determine the ice, snow, and wet area criteria necessary to alert the operator of unacceptable conditions. Work on range improvement enhanced the signal-to-noise ratio and led to an increase of 25 percent in the detection range for ice, snow, and wet surface. Additional improvements involved creating larger collecting optics and increasing the amount of light energy delivered to the photodetector. Further research, development, and testing, however, will be needed before the technology can be applied to the highways. The final report is available from the National Technical Information Service (NTIS # PB2004-105015).



Figure 1

Prototype ice detection system.

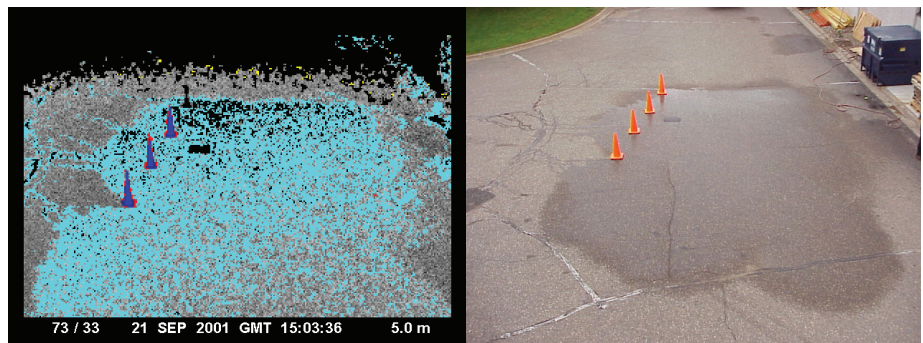

Figure 2

Areas of wet and dry pavement can be detected by the system.

DEVELOPMENT OF A FRACTURE MECHANICS-BASED ASPHALT BINDER TEST METHOD FOR LOW-TEMPERATURE PERFORMANCE GRADING

NCHRP-IDEA Project 84

Simon A.M. Hesp [Tel.: (613) 533-2615, Fax: (613) 533-6669,
Email: simon@chem.queensu.ca]
Queen's University, Kingston, Ontario, Canada, and

Mihai O. Marasteanu
University of Minnesota, Minneapolis, Minnesota

This project developed a test method based on fracture mechanics for predicting low temperature performance of asphalt binders. A low-temperature yield test was developed and validated using asphalt binders modified with commercial polymer modifiers. A simple and accurate low-temperature fracture toughness test for asphalt binders was also developed. The test measures fracture toughness and fracture energy values on three-point bend specimens with aluminum inserts. The use of inserts significantly reduced the sample amount requirement (less than 3 grams) and showed an improvement over the current SHRP procedures. The effect of sample width on fracture toughness was investigated to ascertain the plane strain condition. A survey of Highways 118 and 17 test section data on pavement cracking for use in establishing tests and asphalt binder performance in the field was conducted, and fracture tests on unaged binders and aged binders from these highways were performed. Results indicated a significant improvement of the IDEA test over SHRP tests for fracture and cracking predictions. The final report is available from the National Technical Information Service (NTIS # PB2004-103344).

WATERPROOFING CONCRETE HIGHWAYS

NCHRP-IDEA Project 85

John L. Massingill, Jr. [Tel.: (512) 245-9618, Fax: (512) 245-1892,
Email: john.massingill@txstate.edu]
Texas State University, San Marcos, Texas, and

David W. Fowler

International Center for Aggregates Research, The University of Texas, Austin, Texas

This project evaluated the concept of waterproofing concrete using soybean oil-based phosphate ester polyol (SOPEP) formulations and the effect of these additives on the physico-mechanical properties of fresh and hardened concrete. A number of SOPEP formulations and concentrations for optimum performance in concrete were evaluated through a series of laboratory tests. The different formulations affected mixing and dispersion in concrete differently. They also exhibited the properties of air entraining, water reducing, set retarding, and workability additives, producing reduced slump, reduced water requirement, and increased strength of concrete. Water absorption tests using 2 percent SOPEP showed a decrease of only about 7 percent in water absorption by the concrete indicating the need for higher dosages for waterproofing concrete. The effect of phosphate on oil absorption and dispersion in concrete was also investigated. Results showed the potential of SOPEP dispersions as suitable concrete curing compounds and that of polymerized SOPEP as inexpensive polymers for polymer modified concrete. However, additional research is needed to improve the concrete waterproofing ability of SOPEP formulations. The final report is available from the National Technical Information Service (NTIS # PB2004-103339).

ADVANCED CONCEPT CONCRETE USING BASALT FIBER/BF COMPOSITE REBAR REINFORCEMENT

NCHRP-IDEA Project 86

Dr. Vladimir Brik [Tel.: (608) 244-1349, Fax: (608) 244-9071, Email: v_brik@hotmail.com]
Research & Technology Corp., Madison, Wisconsin

This project evaluated basalt fiber composite rebars as an alternative to steel rebars as concrete reinforcement. Work in the initial stage focused on fabricating basalt fiber composite rebars using U.S. basalt and evaluating and optimizing the properties of rebars for use as concrete reinforcement. Initial tests for concrete-rebar bond strength were conducted with plain, 4-slot, and 8-slot basalt fiber rebars, as well as single-, double-, and triple-twisted cables using ASTM C-234 procedure. The results showed improved bond and no slippage between concrete and rebars with slots. Similar results were obtained for twisted cables. The concrete failure was not caused by bond failure or slippage. Additional laboratory testing of concrete beams and slabs reinforced with basalt fiber composite rebars verified the initial results and provided specifications for rebar parameters for use as concrete reinforcement. The final report is available from the National Technical Information Service (NTIS # PB2003-102862).

AN IN SITU SHEAR TEST FACILITY FOR ASPHALT CONCRETE PAVEMENTS

NCHRP-IDEA Project 87

A. O. Abd El Halim [Tel.: (613) 520-2600 ext.5789, Fax: (613) 520-3951,
Email: ahalim@ccs.carlton.ca]
Carleton University, Ottawa, Canada

This project, a follow-on activity for an earlier IDEA Project (NCHRP-55), focused on the application of an in situ shear strength testing (InSiSST™) facility through theoretical development, field testing, and laboratory verification (Figure 1). The InSiSST™ facility was upgraded to add a rotary displacement transducer to directly measure the angular displacement during field testing to avoid problems due to strain rate variation during testing. A special set up of blanket heaters was devised to control pavement temperature to allow field testing in all types of weather conditions. To avoid epoxy bond failure between pavement surface and steel plate, the system was modified using steel plates with vertical blades that were driven into the pavement surface, thus eliminating the need for the epoxy. This modification also shortened the testing time since waiting time is required for epoxy to harden. The upgraded InSiSST™ facility was tested on several sites along with laboratory tests to confirm the correlation between field and laboratory results. Work on a finite element analysis was completed to establish the optimum evaluation criteria based on the theoretical analysis of the InSiSST™ loading condition. This analytical study included the effects of viscoelasticity, plasticity, and large displacements. The successful completion of these tasks provided correlations between shear parameters measured by the InSiSST™ and field performance of asphalt pavements. The final report is available from the National Technical Information Service (NTIS # PB2004-106776).

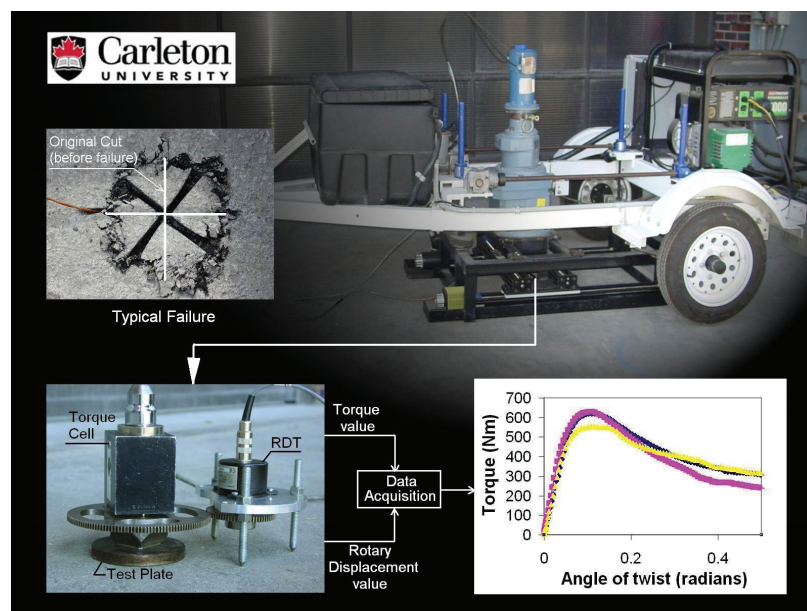

Figure 1

The InSiSST™ system.

AUTOMATED PAVEMENT DISTRESS SURVEY THROUGH STEREOVISION

NCHRP-IDEA Project 88

Kelvin C.P. Wang [Tel.: (470) 575-8425, Fax: (479) 575-7168]

University of Arkansas, Fayetteville, Arkansas

This project developed an automated and mobile high-speed and high-resolution pavement distress survey system for detecting cracks, rutting, and roughness in three dimensions (Figures 1 and 2). Images of pavement surface were obtained through the simultaneous use of two cameras, each with a resolution of 1300 by 1024, and then combined to potentially achieve higher accuracy. Algorithms for 3-D pavement surface were developed. A computer code was written that included a calibration program, distortion adjust program, matching program, and some user interface. The algorithms needed further improvement to enhance accuracy. Initial tests showed accuracy to be within 5 mm. After establishing 3-D geometric mode and necessary image resolution, algorithms for pavement cracks, rutting, and roughness were implemented. Issues with accuracy of the pavement survey parameters and the hardware and software requirements for a real-time pavement survey system capable of traveling and collecting data at highway speeds still need to be fully addressed for the successful field implementation of this technology. The final report is available from the National Technical Information Service (NTIS # PB2004-106775).



Figure 1

The dual-camera subsystem.

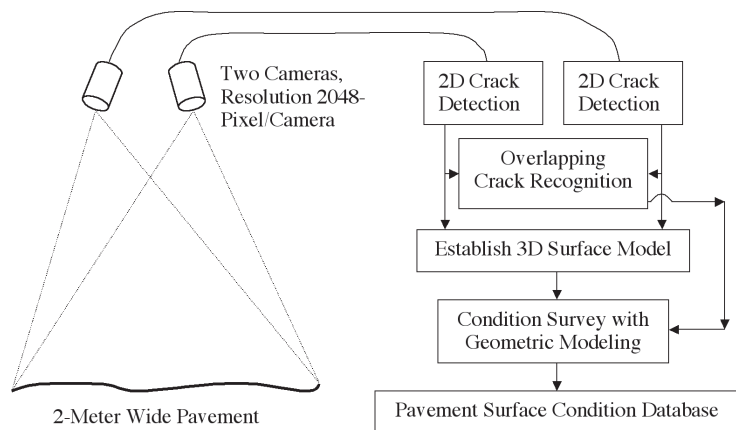

Figure 2

General procedures for automated condition survey with stereovision.

U.S.-SPECIFIC SELF-CONSOLIDATING CONCRETE FOR BRIDGES

NCHRP-IDEA Project 89

Andrzej S. Nowak [Tel.: (734) 764-9299, Fax: (734) 764-4292, Email: nowak@umich.edu]
University of Michigan, Ann Arbor, Michigan

This project was aimed at adapting the self-compacting concrete technology for the U.S. market using domestic concrete materials and practice for use in highway structures. The experimental work focused on designing self-compacting concrete mix formulations with desired workability, segregation resistance, and deformability, as well as testing for standard mechanical properties of the hardened concrete. Following a literature review, materials and equipment were selected and laboratory tests were performed to determine formulations that satisfied the filling and passing requirements for self-compacted concrete. All selected formulations contained fly ash and a superplasticizer. Tests on fresh mixes confirmed the flowability required for self-compacting concrete (Figure 1). However, the concrete mixes showed sensitivity to the mixing sequence. Consequently, tests were conducted to establish a mixing sequence for producing the most reliable and consistent results. Compressive strength tests showed rapid gain in strength: 3-day strengths approximated 80 percent of the 28-day strengths. The 28-day compressive strengths were almost 100 percent higher than those for conventional concrete. The modulus of elasticity tests showed an increase of about 30-45 percent over conventional concrete. The freeze-thaw resistance tests showed durability factors in the range of 87-98 percent. The segregation tendency of self-consolidating concrete can be controlled by controlling the amount of superplasticizers. The higher unit cost of self-consolidating concrete (about 50 percent higher than conventional concrete) is largely offset by the use of less material and increased durability. The final report is available from the National Technical Information Service (NTIS # PB2005-109494).

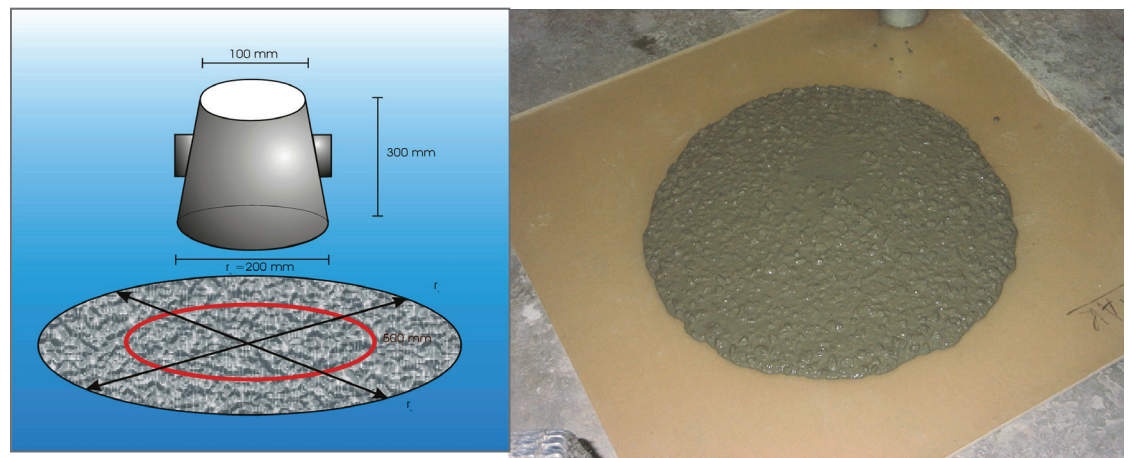

Figure 1

Slump flow test, typical range of diameters for SCC is 26-32 inches and the time to reach 20 inches is 2-5 seconds.

ROBOTIC HIGHWAY SAFETY MARKERS

NCHRP-IDEA Project 90

Shane Farritor [Tel.: (402) 472-5805, Fax: (402) 472-1465

Email: sfarritor@unl.edu, Web: [Http://robots.unl.edu](http://robots.unl.edu)]

University of Nebraska, Lincoln, Nebraska

This project was aimed at developing a robotic safety marker system consisting of mobile signs, cones, and other safety devices to provide safety to workers in the work zone (Figure 1). A robotic safety marker system was designed along with a global laser-based sensor system capable of locating barrels up to 80 meters away with an accuracy of a few centimeters. Software was developed to integrate the sensor with the system, and a mathematical-matching algorithm was developed to determine the location of the barrel robot relative to the global sensor. Following the design and fabrication of a robot safety sign to complement the safety barrel robots, a functional system was produced by full integration of the global planning, sensing and communication systems. Both the global and local control schemes were tested without involving a human in the loop. The desired and actual paths for each robot showed good agreement and the tests took less than two minutes to complete (Figure 2). The control algorithm was successfully used for the relative movements of the robots and the global sensor. A new tracking system software was created to allow the global sensor to track the location of the barrels in real time, and an initial test successfully tracked a group of five robots in a realistic environment. The new tracking software should help develop a new control algorithm that will allow continuous motion of the barrel robots. Movies on project results showing moving safety robots can be viewed at <http://robots.unl.edu/projects/current/barrelrobots/index.html>. The project has received considerable national and international media attention. The final report is available from the National Technical Information Service (NTIS # PB2005-106347).

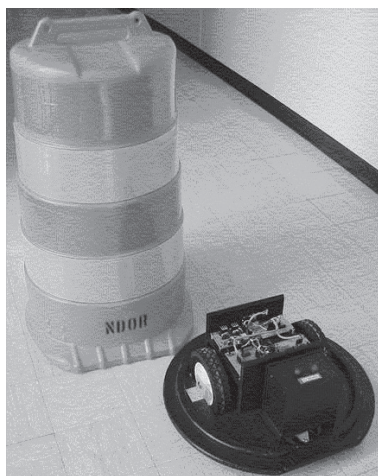

Figure 1

A robotic highway safety marker.

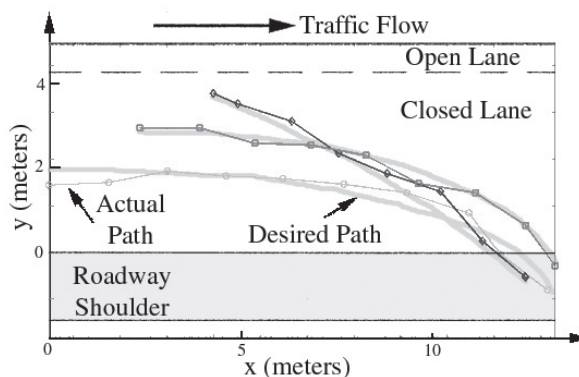

Figure 2

Desired and actual paths during field test.

APPLICATION OF SHAPE MEMORY ALLOYS IN SEISMIC REHABILITATION OF BRIDGES

NCHRP-IDEA Project 91

Reginald DesRoches [Tel.: (404) 385-0826, Fax: (404) 894-0211]

Georgia Institute of Technology, Atlanta, Georgia

This project, a follow-on activity of an earlier IDEA project (NCHRP-65), focused on the application of shape memory alloy (SMA) restrainers to improve the resistance of highway bridges to seismic damage. Work in the initial stage involved developing cost-effective and mechanically stable SMAs for bridge rehabilitation that included ternary alloys of Ni and Ti doped with Fe or Cr. The results show that the binary form of SMAs (NiTi) exhibited superior performance as compared with the ternary NiTiCr or NiTiFe alloys. The performance of SMAs was optimized by thermo-mechanical processing. The effect of temperature on the superelastic cyclic properties of selected alloys was also evaluated in order to establish the optimum performance temperature range.

SMA-based prototype restrainers were fabricated and evaluated in dynamic laboratory and shake table tests. The restrainers were found to be superior to steel restrainers in limiting relative hinge displacements, with maximum hinge displacement being about half of steel restrainers (Figure 1). The restrainers also showed minimal residual strain after repeated cycling and, unlike steel, could undergo many loading cycles with little degradation of properties. Further, with equivalent restrainers under identical earthquake motion, the SMA restrainers produced lower block acceleration as compared to steel restrainers and reached only their yield level while the steel restrainers failed. Full-scale tests on bridges are needed to demonstrate the applicability of the technology in the field. The final report is available from the National Technical Information Service (NTIS # PB2005-109518).

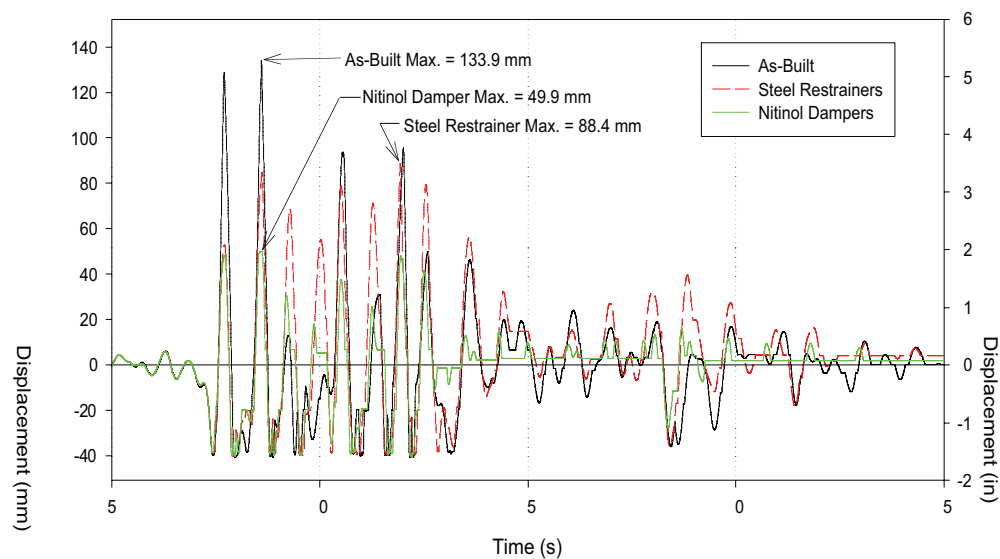

Figure 1

Results of analysis showing relative hinge opening with steel cable restrainers and SMA restrainers.

DEVELOPMENT OF AN ADAPTIVE DAMPER FOR CABLE VIBRATION CONTROL

NCHRP-IDEA Project 92

Steve C. S. Cai [Tel.: (225) 578-8898, Fax: (225) 578-8652, Email: cscai@lsu.edu]
Louisiana State University, Baton Rouge, Louisiana

This project developed and tested a tuned mass damper (TMD) system capable of adapting automatically to control cable vibrations in stayed-cable bridges. Figure 1 illustrates the proposed concept. Following a review of background information on TMD system and evaluating the performance of the magnetorheological (MR) fluids, a cable system was built to test the concept feasibility using parameters developed for a preliminary model that was based on the scaling theory. Data from laboratory experiments showed that the MR damper effectively reduced cable vibration by adding supplementary damping to the cable system with or without current and that there was an optimal current for producing optimal damping. This optimal current value depended on the properties of the cable system and the MR damper. The reduction in cable vibration showed dependence on the closeness between the TMD system frequency and the cable natural frequency and on the nature of the dissipative liquid. The closer the two frequency values, the easier the transfer of cable vibration energy to the TMD. Also, the more viscous the dissipative liquid, the easier the dissipation of TMD vibration energy. The results indicate that an adaptive TMD-MR damper system can be developed by choosing appropriate stiffness, mass, and MR damper. After the design and fabrication of dampers on the scaled prototype, testing and evaluation of both single and multi MR-TMD systems was carried out with promising results. The best effect of the TMD-MR damper on cable vibration reduction was shown when the natural frequency of TMD-MR is closer to that of the cable. The final report is available from the National Technical Information Service (NTIS # PB2005-106346).

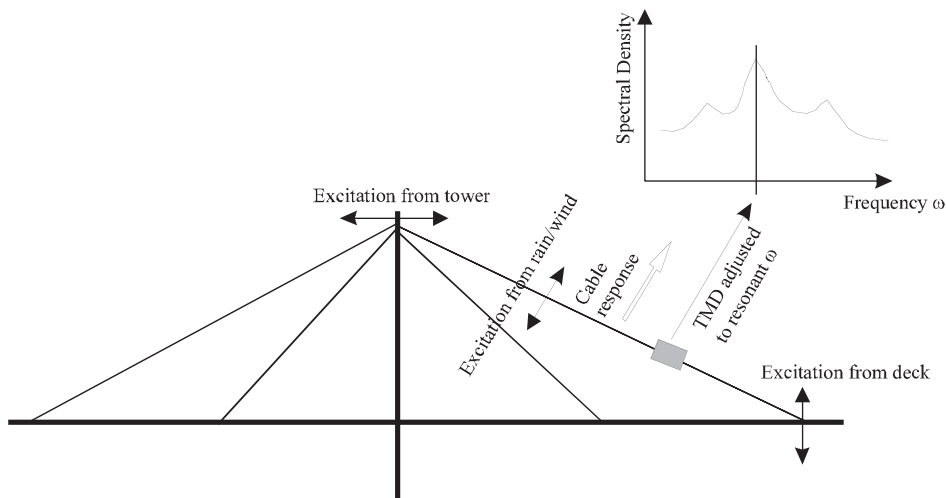

Figure 1

Sketch of cable vibration control strategy.

ADVANCED RELOCATABLE TRAFFIC SENSOR SYSTEM (ARTS)

NCHRP-IDEA Project 93

Eddie Neal [Tel.: (703) 276-3377, Fax: (703) 276-0996, Email: eddieneal@scientextcorp.com]
The Scientex Corporation, Alexandria, Virginia

This project developed and tested a portable advanced relocatable traffic sensor (ARTS) system based on microwave radar technology and wireless communication for improving the accuracy and effectiveness of work zone ITS systems (Figure 1). The system components included Doppler microwave radar, digital compass, solar portable power system, GPS positioning subsystem, satellite packet data terminal, palm-size single board computer, and electronic interface board. The components were designed or purchased and integrated into a compact prototype system that satisfied the requirements for portability, low cost, self-power, built-in satellite communication links, self-diagnostics, self-configuring, modularity, and ability to provide accurate measures of traffic counts, speed, volume, and headway. Laboratory tests using a tuning fork to simulate vehicle speeds were performed that validated the satellite communications and speed data acquisition aspects of the system. Limited field tests were performed to test the satellite communications and speed acquisition in actual traffic. Observed data accuracy and communications transmission durations of a few seconds provided encouraging indication of the potential for using ARTS in real time applications for work zone safety and incident management applications. However, further improvements, such as using ultraband radar instead of Doppler microwave transceiver, and hardware enhancement to reduce the system's size and additional field tests are needed before it can be implemented by highway agencies. The final report is available from the National Technical Information Service (NTIS # PB2005-109517).

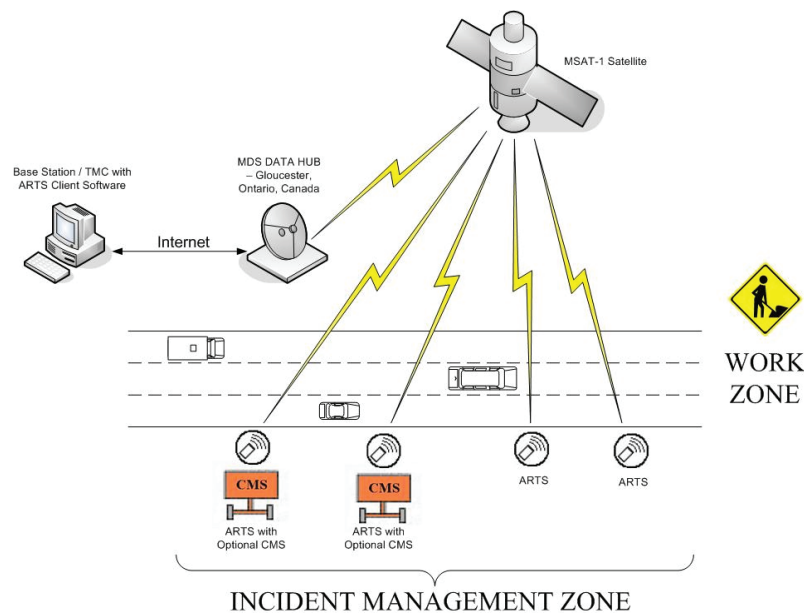

Figure 1

Advanced relocatable traffic sensor for work zone and incident management systems.

LIQUEFACTION MITIGATION USING VERTICAL DRAINAGE: FULL-SCALE TESTING

NCHRP-IDEA Project 94

Kyle M. Rollins [Tel.: (801) 422-6334, Fax: (801) 422-0159, Email: rollinsk@byu.edu]
Brigham Young University, Provo, Utah

In this project, full-scale field tests were performed to investigate the use of vertical composite drains (EQ-Drains) in dissipating pore pressure to prevent liquefaction during an earthquake. The EQ-Drains were evaluated at a test site in Vancouver, British Columbia, using controlled blasting technique to liquefy loose sand. Installing EQ-Drains using high vibration typically increased relative density by about 10 percent and produced volumetric strains of 2.5 percent. This effectively reduced the amount of settlement and increased the rate of pore pressure dissipation relative to untreated sites. Controlled blasting also showed the potential to produce significant densification of liquefiable soils. Settlements of 2 to 4 percent of volume were produced for small charge masses and relative density was typically increased by 7-10 percent. The presence of EQ-Drains significantly increased the rate of excess pore water pressure dissipation relative to untreated areas (Figure 1). Even though drains did not prevent liquefaction for the high stress levels imposed by the blast tests, settlements in areas where drains were installed using conventional procedures was reduced to only about 60 percent of the settlement measured in untreated areas. With minor input parameters modifications, computer analyses were successful in matching measured pore pressure and settlement response during blasting. Results of the computer model analysis indicate that the drains can prevent liquefaction and excessive settlement when drain diameter and spacing are properly designed for the expected earthquake. The committee approved a follow-on project for additional field tests at the Treasure Island site in California. The final report is available from the National Technical Information Service (NTIS # PB2004-103340).

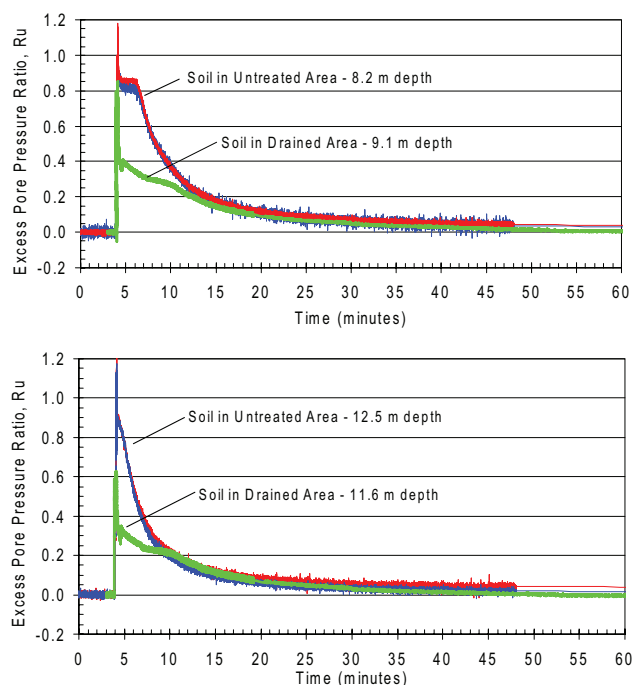

Figure 1

Comparison of time histories of excess pore pressure for areas with and without drains.

pore pressure

CONCRETE ROAD RECYCLER—HAMMER-ANVIL TEST

NCHRP-IDEA Project 95

Deems Pfaff [Tel.: (970) 476-6577, Fax: (970) 476-0504]

Road Processing Resources Inc., Vail, Colorado

This project upgraded and tested a gravity drop hammer of a prototype mechanical system developed in NCHRP-79 project for removing, fragmenting, and recycling concrete pavement (Figure 1). A detailed engineering study was conducted to develop the final configuration of the power hammer. The hammer retaining guides were redesigned using high-density plastics to provide longer life than the presently used metal-to-metal system. The gravity drop control system was evaluated for multi-hammer operational sequencing. Following system analysis and refinement, the design of a pneumatic power hammer was finalized to operate in a 6-hammer sequence on a 12-foot wide lane. A prototype pneumatic hammer system was built for testing including controls that can perform in a group of six hammers. The gravity drop hammers were installed on a mobile rig and tested. The process successfully worked on concrete slabs of thickness up to 8 inches thick, producing a 40 percent recyclable aggregate mix for use in concrete. A commercial version of the stationary machine is now available. Further development and improvement of the system with private industry support has continued with a goal to produce the final mobile version of the road-recycling machine.

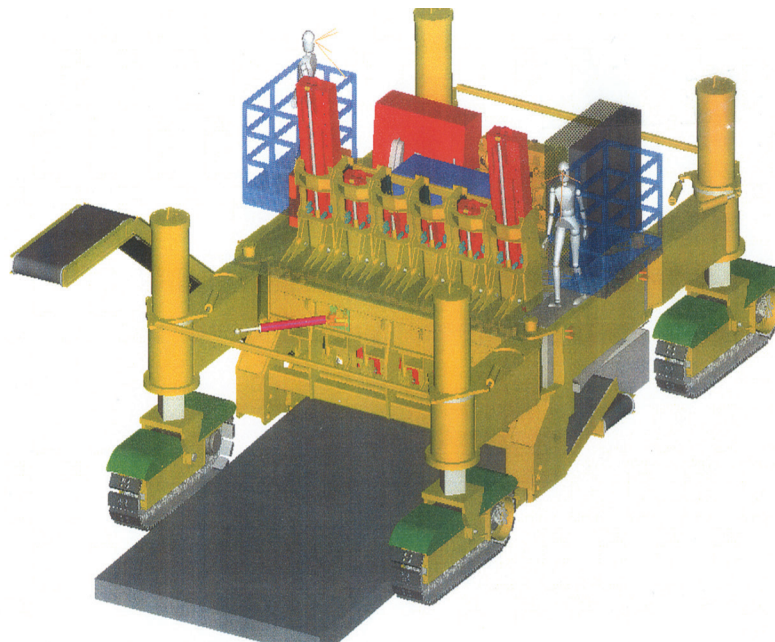

Figure 1

USING ULTRASOUND OF MHZ FREQUENCY FOR TESTING CONCRETE

NCHRP-IDEA Project 96

Sandor Popovics [Tel.: (610) 623-0116 and (215) 895-2345, Email: popovics@coe.drexel.edu]
OPTIMUM Engineering Research, Lansdowne, Pennsylvania

This project developed and demonstrated the feasibility of a nondestructive ultrasonic technique based on modified split spectrum processing (SSP) and its rationalization using a statistical spectral histogram technique (SHT) for field evaluation of highway concrete structures. SSP enhances the signal-to-noise ratio by reducing the intensive background noise accompanying high-frequency ultrasound in concrete, and SSP rationalization eliminates the time-consuming trial and error approach, greatly improving the method for practical applications. Following the selection, evaluation and optimization of the initial instrumentation, a new algorithm was developed that allowed automatic selection of optimum or near optimum parameters for split spectrum processing and performing the split spectrum processing using the selected parameters. A software system was developed that allowed spectral histogram analysis for the direct determination of the frequency region without trial and error. The software was successfully tested for several cases, including the determination of thickness and internal defects of a concrete slab. The combination of SSP with SHT reduced the noise, thereby significantly improving the interpretation of the received high frequency ultrasound. Also, the computerized form made the application simple and rapid. The improved process can further be extended to produce two-dimensional images for improved diagnosis of concrete structures. The researcher collaborated with Pennsylvania and Delaware DOTs for field testing and implementation. The researcher also worked with the American Concrete Institute's Committee 228 on Nondestructive Testing of Concrete to publicize the innovation. The final report is available from the National Technical Information Service (NTIS # PB2005-100682).

FIBER-REINFORCED PLASTICS FOR SEISMIC BRIDGE RESTRAINERS

NCHRP-IDEA Project 97

M. Saiid Saiidi and E. Manos Maragakis [Tel.: (775) 784-4839, Fax: (775) 784-1390,
Email: saiidi@unr.edu]
University of Nevada, Reno, Nevada

This project evaluated the use of fiber-reinforced plastic (FRP) fabrics as restrainers in the seismic rehabilitation of highway bridges as an alternative to steel for restrainer construction to reduce bridge hinge movement during earthquakes. Glass, carbon, and glass/carbon hybrid restrainers were constructed and evaluated in large-scale dynamic laboratory tests. The research effort included (i) tensile tests on FRP strips and on FRP/concrete bond at various loading rates, (ii) FRP restrainer development and dynamic testing, (iii) shake table tests, data analysis, performance comparison for FRP, steel, SMA restrainers, and (iv) development of a FRP restrainer design method.

The results showed that the FRP strength was insensitive to strain rate and that the FRP/concrete bond was a function of concrete shear strength but insensitive to strain rate. The results also demonstrated methods for flexible restrainer construction and restrainer/concrete bonding. A simplified FRP restrainer design method, considered more realistic than that of AASHTO was proposed (Figure 1) that takes into account the dynamic characteristics of a bridge structure. The final report is available from the National Technical Information Service (NTIS # PB2007-100047).

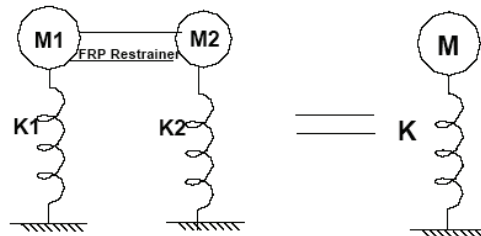

Figure 1

New restrainer design method.

VOID DETECTION IN POST-TENSIONING DUCTS USING TIME-DOMAIN REFLECTOMETRY

NCHRP-IDEA Project 98

Robert Hunsperger [Tel.: (302) 831-8031,
Email: robert_hunsperger@usa.net or hunsperg@eecis.udel.edu]

Michael Chajes [Tel.: (302) 831-2442, Email: chajes@ce.udel.edu]
University of Delaware, Newark, Delaware

This project developed and evaluated a nondestructive method, based on time domain reflectometry (TDR), to determine the presence of voids in post-tensioned ducts in highway structures. Figure 1 shows the TDR measurement apparatus setup. The voids were detectable using a single sensor wire in conjunction with an existing tensioning cable to form the two-wire transmission line. The voids could also be detected by using commercially available transmission lines, such as lamp cord or 300 ohm TV cable. Factors affecting the void detection signal were identified, and their effects quantified. The presence of sand, water, or moisture tended to decrease the positive amplitude of the reflected TDR signal but the void was still detectable. Work on using external sensors for void detection showed much weaker signals as compared to internal sensors, indicating a need for a more powerful pulse generator and pulses of high magnitude and short rise time. While higher output voltage with high rise time did not lead to any improvement, a rise time of 40-100 ps appeared satisfactory. Parameters for TDR meters for field application with external sensor detection were identified and several commercial portable TDR meters were evaluated. Further refinement and evaluation of the technique is necessary before it can be implemented for field applications. The final report is available from the National Technical Information Service (NTIS # PB2007-105524).

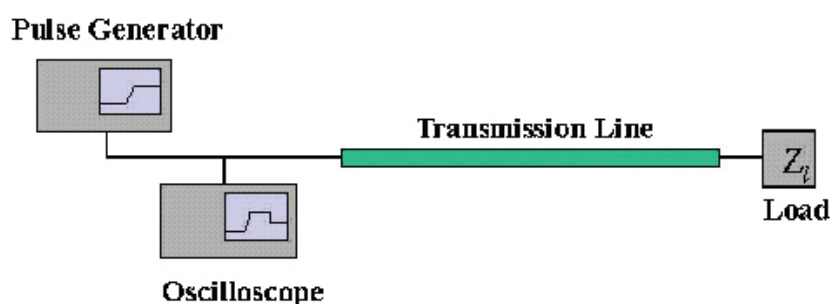

Figure 1

Time domain reflectometry measurement apparatus.

DEVELOPMENT OF ASPHALT BINDER CRACKING DEVICE

NCHRP-IDEA Project 99

Sang-Soo Kim [Tel.: (740) 593-1463, Fax: (740) 593-0625,

Email: skim@bobcat.ent.ohiou.edu] Ohio University, Athens, Ohio

This project developed a simple asphalt binder cracking device (ABCD) to determine the thermal cracking temperature of asphalt binders. In initial experiments, cracking temperatures determined by using ABCD with aluminum molds and rings appeared much lower than those determined by Superpave procedures (MP1 and 1a). Consequently, the ABCD setup was modified using silicone molds and invar and steel rings that produced more accurate and repeatable results (Figure 1). A computer program was developed to calculate theoretical thermal stress developed during ABCD tests. When appropriate coefficients of thermal expansion (CTEs) of ABCD ring and binders were used, the theoretical and experimental values of thermal stress agreed satisfactorily. When compared with AASHTO MP1 and 1a tests, the ABCD test showed best correlation with the thermal stress restrained specimen test (TSRST) for cracking temperature. The test also revealed a significant effect of polymer content on cracking temperature and fracture strength as compared to AASHTO M320 test. Additional work was carried out to improve the ABCD ring design and the data acquisition system. A ring with a biaxial strain gauge, a temperature sensor, and a Ni-chrome spot-welded connector bracket significantly improved the accuracy. The test method was further refined and evaluated with support from FHWA's Highways for LIFE Program. A test procedure based on ABCD for determining the thermal cracking temperature of asphalt binders has been adopted by AASHTO as a provisional standard (TP 92). (NTIS Report # PB2008-106867)

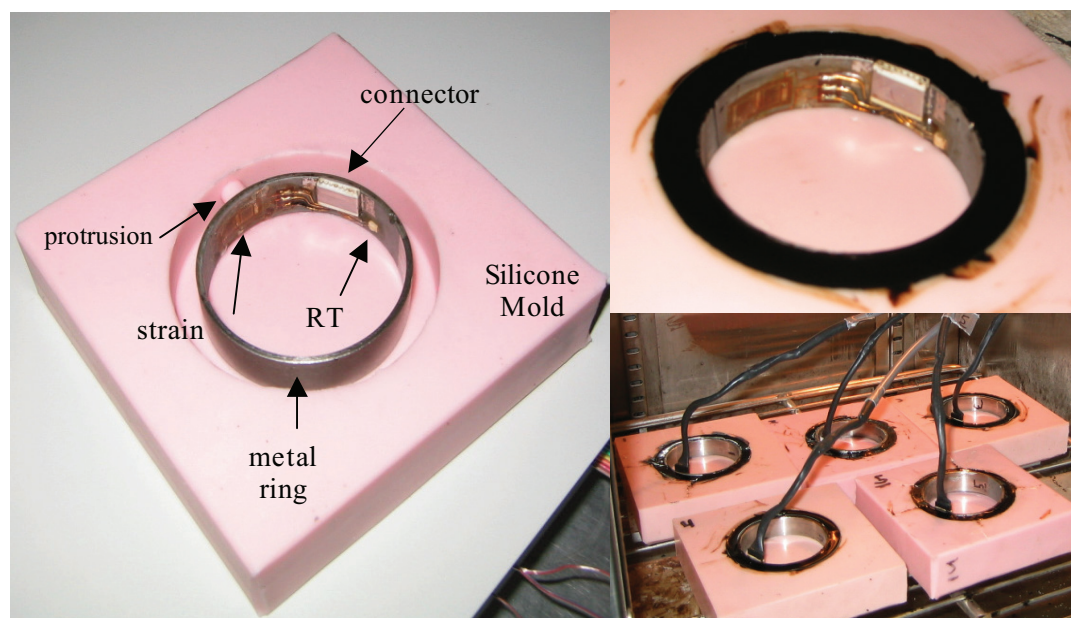

Figure 1

ABCD ring in a silicone mold (left); binder specimens prepared for ABCD test (right).

EVALUATION OF AL-ZN-IN ALLOY FOR GALVANIC CATHODIC PROTECTION OF BRIDGE DECKS

NCHRP-IDEA Project 100

W. Young [Tel.: (610) 344-7002, Fax: (610) 344-7092, Email: wyoung@corrpro.com]
Corrpro Companies Inc., West Chester, Pennsylvania

An alloy was developed under FHWA Project FHWA-RD-96-171 for use as a galvanic anode for the protection of steel-reinforced concrete bridge substructures. The alloy consists of 20 percent zinc, 0.2 percent indium, with the balance aluminum. Indium, the key component, keeps the anode active even in dry environments. The anode is applied to concrete substructures using thermal spray technology, typically electric arc spray. The objective of project NCHRP-100 was to develop a galvanic anode mesh for bridge deck application. The concept was to develop an expanded mesh or perforated sheet that meets the following criteria:

1. The galvanic anode material is sufficient to last a minimum of 25 years.
2. The anode mesh is durable for construction application.
3. The mesh openings are sufficiently large not to hinder the concrete overlay bonding.
4. The sheet size is practical for transportation and field installation.

An anode consisting of aluminum mesh with the Al-Zn-In alloy thermally sprayed onto an aluminum mesh was successfully applied to a bridge deck on Interstate 44 in Cuba, Missouri, in July 2005. This anode was tested periodically since then and found to be effective in protecting the rebar in the area it was installed. A further test installation using aluminum mesh with a thermally sprayed Al-Zn-In alloy coating is planned. Difficulties were encountered in obtaining the correct alloy to produce the anode. Some disbonding of the anode on the Cuba, Missouri bridge deck was noted at the last inspection. Localized delamination of the anode on the bridge deck has been observed. Testing in October 2008 revealed additional delamination and a significant reduction in anode current output. Material supply problems and the implementation of this task have delayed the installation of additional test installations. While this does not preclude the use of this technology, further work is needed to evaluate and resolve these issues. If this galvanic anode is successfully developed, a virtually maintenance-free CP system for bridge decks is expected to be developed. As a result, hundreds of millions of dollars could be saved repairing damage caused by corrosion of the nation's bridge decks. (NTIS # PB2010-101385)

ACTIVE HEATING INFRARED THERMOGRAPHY FOR DETECTION OF SUBSURFACE BRIDGE DEKTERIORATION

NCHRP-IDEA Project 101

Kenneth R. Maser [Tel.: (781) 648-0440, Fax: (781) 648-1778, Email: kmaser@infrasens.com]
Infrasense Inc., Arlington, Massachusetts

This project developed a method based on the technique of active heating infrared thermography for detecting delamination and deterioration in bridge decks. The method involves briefly heating the deck with high-intensity pavement heaters and then detecting the temperature differentials at delaminations using infrared thermography. Analytical studies employing a thermal/mechanical model showed that detectable differentials can be produced using the output of a standard pavement heater with 5-10 seconds of heating application. Laboratory studies on slabs with simulated delaminations incorporated at different locations and depths with 10-second heating confirmed detectable temperature differentials at the delaminated locations (Figure 1).

A cost analysis estimate shows that for a standard overpass bridge, the infrared method is less than half the cost of the conventional chain dragging method and occupies the structure for one tenth of the time. For a four-lane bridge, 180 ft long and with a surface area of about 8,600 sq ft, the chain drag method cost over \$7,200, required 42 hours of the field technician's time and 21 hours of lane closure. The infrared heating method cost about \$3,600, requiring only four hours of the technician's time and two hours of moving lane closure. Further field testing and demonstration is needed to implement this technology for highway application. The final report is available from the National Technical Information Service (NTIS # PB2005-100681).

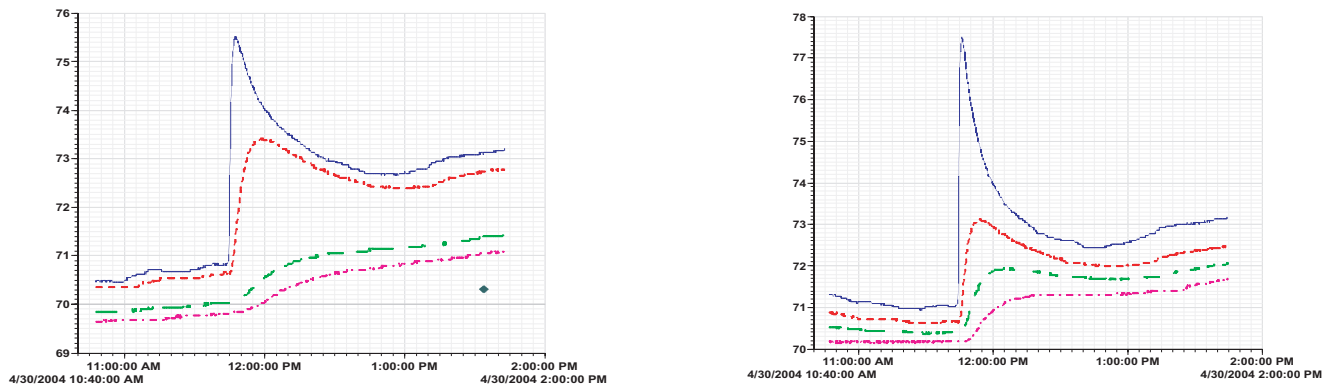

Figure 1

Temperature profiles: (left) at delamination and (right) in sound area at various sensor depths.

NONDESTRUCTIVE EVALUATION METHOD FOR DETERMINATION OF INTERNAL GROUT CONDITIONS INSIDE BRIDGE POST-TENSIONING DUCTS USING ROLLING STRESS WAVES FOR CONTINUOUS SCANNING

NCHRP-IDEA Project 102

Yajai Tinkey and Larry D. Olson [Tel.: (303) 423-1212, Fax: (303) 423-6071,
Email: yajai@olsonengineering.com, ldolson@olsonengineering.com]
Olson Engineering Inc., Wheat Ridge, Colorado

This project developed a nondestructive method based on impact-echo technique with continuous scanning features (Figure 1) and spectral analysis of surface waves for determining the grout condition inside post-tensioned bridge ducts. Work in the first phase focused on evaluating and establishing the accuracy/reliability of the impact echo scanning test. The impact echo scanner hardware was modified by incorporating a rolling transducer into the prototype to overcome the problem of variable thickness. The scanner software was also improved to provide three-dimensional display of impact echo results. Data on a mock-up slab fabricated with defects of different types and sizes and collected using the modified instrument was analyzed. Visualization from three-dimensional surface plots helped interpret the data. The presence of a tendon duct and grouting discontinuities appeared to cause an increase in the apparent slab thickness. The contractor procured two U-shaped precast bridge girders with four ducts on each wall from Colorado Department of Transportation for a full-scale test. Impact echo tests using a rolling scanner at different times after the grouting process were performed on the walls of the girders. The results showed good agreement with the actual defect design. The clearest indication of the presence of grouting defect was given by the apparent increase in slab thickness due to a reduction in the impact echo resonant frequency (caused by a decrease in stiffness associated with a defect). Work in the second and final stage focused on building and refining a prototype. The equipment is now ready for implementation and is commercially available. The final report is available from the National Technical Information Service (NTIS # PB2007-107314).

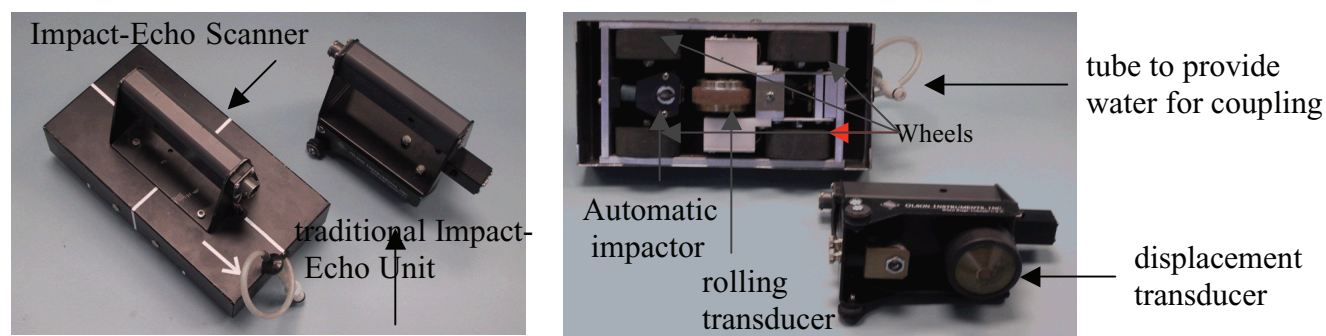

Figure 1

Impact Echo Scanning Unit and Traditional Impact Echo Unit.

LIQUEFACTION MITIGATION USING VERTICAL COMPOSITE DRAINS: FULL-SCALE TESTING FOR PILE APPLICATIONS

NCHRP-IDEA Project 103

Kyle M. Rollins [Tel.: (801) 422-6334, Fax: (801) 422-0159, Email: rollinsk@byu.edu]
Brigham Young University, Provo, Utah

This follow-on project to an earlier IDEA project (NCHRP-94) involved full-scale field tests to evaluate the liquefaction mitigating effect of vertical composite drains for pile applications (Figure 1). Work in the first phase focused on site characterization and blast testing in an untreated area. A pattern of small explosive charges was established for detonation to simulate the liquefaction process produced by an earthquake, and pilot tests were performed with various charge weights and delays to better simulate the duration and intensity of an earthquake and to determine the energy required to induce liquefaction. The contractor had to change the location of the field test because California withdrew permission for the initially approved Treasure Island site. The new test site is near Vancouver, British Columbia. Beginning with the pilot blast liquefaction testing, all tests were completed by the end of summer 2006. The tests also included pile-load testing before and after blast testing in areas treated and untreated with drains. The field test results were complemented with modeling analysis to determine likely

pore pressure response in the area treated with drains. The test results and modeling analysis verified the effectiveness of the proposed approach. The final report is available from the National Technical Information Service (NTIS # PB2007-109590).



Figure 1

Installation of slotted drain pipe within vibrating mandrel.

IMPROVED LOW-TEMPERATURE AND FATIGUE-PERFORMANCE GRADING OF ASPHALT BINDERS

NCHRP-IDEA Project 104

Simon Hesp [Tel.: (613) 533-2615, Fax: (613) 533-6669, Email: simon@chem.queensu.ca]
Queen's University, Kingston, Ontario, Canada

This project refined and evaluated a test method developed in an earlier IDEA project (NCHRP-84) based on fracture mechanics for predicting the low temperature performance of asphalt binders. Fracture performance properties of selected asphalt binders from various pavement trial sections in Canada (particularly from Highway 655), along with additional commercial materials were determined using the developed tests. The ductile fracture properties varied by a significant amount; the mixture that showed the highest essential work of fracture performed well in the field, while those with lower works of fracture performed poorly. In contrast, the mixture that performed best in the repeated compression tests at both 25°C and 40°C, performed worst in service, suggesting that this test measures properties that show little relevance for fracture performance. Failure properties at low temperatures in both creep tests and in controlled-crack-opening displacement tests were determined. Based on research results, the Ontario Ministry of Transportation has approved two additional pavement trials, one on Highway 417 and the other on a new section of Highway 655. These and other test sections are being used in the validation tests for the laboratory standards developed under the two IDEA projects. Several other agencies (Ontario Ministry of Transportation, Imperial Oil of Canada, and the Science and Engineering Research Council of Canada) have collaborated in this IDEA effort. The key deliverables from the proposed effort are as follows:

- LS-296 (draft)–Asphalt Cement Grading for Fracture Performance using Single-Edge-Notched Bend Procedure;
- LS-298 (draft)–Asphalt Cement Grading for Fracture Performance using Compact Tension Procedure;
- LS-299 (draft)–Asphalt Cement Grading for Fracture Performance using Double-Edge-Notched Tension Procedure; and
- LS-308–Determination of Performance Grade of Physically Aged Asphalt Cement using Extended Bending Beam Rheometer (BBR) Method.

These four methods provide practical and improved low-temperature and fatigue binder specification tests. The research team is working closely with the Materials Engineering and Research Office of the Ministry of Transportation of Ontario and with users and producers in the Canadian asphalt industry to get the specification test method included in all future hot mix contracts. The final report is available from the National Technical Information Service (NTIS # PB2007-107317).

EVALUATION OF NEW METHODS TO MEASURE WATER-TO-CEMENT RATIO OF FRESH CONCRETE

NCHRP-IDEA Project 105

Art Crotzer [Tel.: (405) 372-9595, Fax: (405) 372-9537, Email: acrotzer@nomadics.com]
Nomadics Inc., Stillwater, Oklahoma

Steve Trost [Tel.: (405) 412-7879, Email: steve@ssi.us]
Strategic Solutions International, LLC, Stillwater, Oklahoma

Michael Fox [Tel.: (405) 533-3770, Email: mfox@engius.com]
Engius, LLC, Stillwater, Oklahoma

This project explored new methods to determine the water-to-cement ratio of fresh concrete. Several new approaches for measuring the water/cement ratio of fresh concrete based on the principles of turbidity and unit-weight/specific-gravity, fluorescence, and radiographic attenuation were initially evaluated. Of all these methods, the approach based on unit weight/specific gravity measurements appeared to be most promising provided certain physical properties of concrete were known in advance. Consequently, work focused on the design, fabrication, and testing of a prototype water/cement meter based on unit weight measurements.

Two systems were developed that involved the measurements of the specific gravities of fresh concrete, cement, flyash as well as the ratios of flyash to cementitious materials and sand, and mathematical equations were derived to calculate the water-to-cement ratio based on these ratios. Results showed good predictive capability of water/cementitious materials ratio with a coefficient of determination of 99.89% and a standard error of 0.77%. A modified microwave oven drying method provided results with a coefficient of determination of 98.7% and a standard error of 2.2%. Efforts have been initiated for marketing, manufacturing, and commercialization of the results of this research and licensing and intellectual property agreements with all involved parties are already in place, which will allow a smooth transition from development and validation to commercialization. The final report is available from the National Technical Information Service (NTIS # PB2008-106868).

AUTOMATED REAL-TIME PAVEMENT CRACK DETECTION AND CLASSIFICATION

NCHRP-IDEA Project 106

Heng-Da Cheng [Tel.: (435) 797-2054, Fax: (435) 797-3265, Email: hengda.cheng@usu.edu]
Utah State University, Logan, Utah

This follow-on project to an earlier IDEA project (NCHRP-81) refined and evaluated in the field an automated high resolution imaging system to detect and classify pavement cracks in real time at highway speeds. The integrated pavement crack analysis and detection system with camera and accessories was installed on a vehicle (Figure 1). While field tests demonstrated the system's capability of recording and processing of images at speeds up to 80 miles per hour, the camera performed unsatisfactorily for the desired resolution. Consequently, a line camera with necessary specifications was procured and used to collect additional data. However, the line camera showed problems with synchronization, white light calibration, and interruption in image capture with change in scan rate. Use of wide angle lens with area cameras produced distortion in the captured images. While an interpolation method appeared to help correct the distortion, it greatly increased the processing time. A satisfactory solution was to use two cameras without the wide-angle lens. This approach was used in field testing by the Utah Department of Transportation (DOT). The testing program used five descriptive statistics (accuracy, sensitivity, specificity, positive predictive value, and negative predictive value) to objectively evaluate the system's performance. The tests results and feedback from Utah DOT were used to refine and upgrade the system. The final integrated system is ready to survey pavement distress on highways. The detailed list of test images and results can be downloaded from the website <http://cvprp.cs.usu.edu/idea>. The final report is available from the National Technical Information Service (NTIS # PB2007-107318).



Figure 1

Integrated pavement crack analysis system installed on a vehicle.

MOBILE GEOPHYSICAL TECHNOLOGY: A SUBSURFACE SCOPING TOOL FOR REDUCING UNFORESEEN ROADBLOCKS IN PROJECT DELIVERY

NCHRP-IDEA Project 107

John A. Lopez [Tel.: (707) 678-2330, Fax: (707) 471-6502, Email: johnlopez@ argustec.com]
Argus Technologies Inc., Dixon, California

This project demonstrated the application of a new mobile geophysical technology, based on electromagnetic induction technology, to detect subsurface features and objects for highway-related projects (Figure 1). Two highway projects were identified in collaboration with Caltrans for evaluating the mobile geophysical technology. The first project was a road-widening Donner Road Rehabilitation Project along highway I-80 (Nevada County). The IDEA work in this project investigated the geological composition of the soils beneath I-80. The second project was a bypass Cherry Avenue Project between Taft and Bakersfield (Western Kern County). The IDEA work determined soil texture density differences, identified plumes, and selected geotechnical boring locations. The electromagnetic signatures were correlated with soil conditions and used to identify differences in geology, landform, and roadbed materials. In both projects, the data obtained by the geophysical equipment provided a more complete understanding of the subsurface conditions and allowed construction plans to be updated and their accuracy improved. The final report is available from the National Technical Information Service (NTIS # PB2007-109638).



Figure 1

Mobile geophysical subsurface scoping equipment.

PILOT STUDY OF 3D-CENTRIC MODELING PROCESSES FOR INTEGRATED DESIGN AND CONSTRUCTION OF HIGHWAY BRIDGES

NCHRP-IDEA Project 108

Stuart S. Chen [Tel.: (716) 645-2114, Fax: (716) 645-3733, Email: Stuartschen@hotmail.com]
State University of New York (SUNY), Buffalo, New York

This project developed and tested a 3D-centric model for an integrated design and construction process for highway bridges. An integrated design of the 3D-centric model was developed. Workflow aspects that were addressed include the following: parametric data entry and management, line girder analysis under AASHTO LRFD (Load and Resistance Factor Design) loadings, AASHTO LRFD design checks, database maintenance and augmentation as the work progresses, 3D CAD modeling, selected contract plan and “shop drawing” generation, extraction of quantity takeoffs for cost estimating, material procurement and shop material management, and export of Computer Numerical Control instructions for automated fabrication by suitably configured shop equipment. Examples of bridge models that were generated are shown in Figure 1. From the single central 3D model current project information relevant to a given project stakeholder (e.g., owner, designer, contractor, fabricator, detailer, precaster, erector) can be extracted at any given time. A pre-stressed concrete bridge provided by Pennsylvania Department of Transportation was modeled parametrically in 3D and was evaluated to record lessons learned about how parametric 3D modeling should be conducted for a real bridge design and construction project. The final report documents the requirements for needed standards and “best practices” pragmatics for 3D-centric approaches and accompanying electronic data interchange for streamlining construction and design processes. The final report is available from the National Technical Information Service (NTIS # PB 2007-107319).

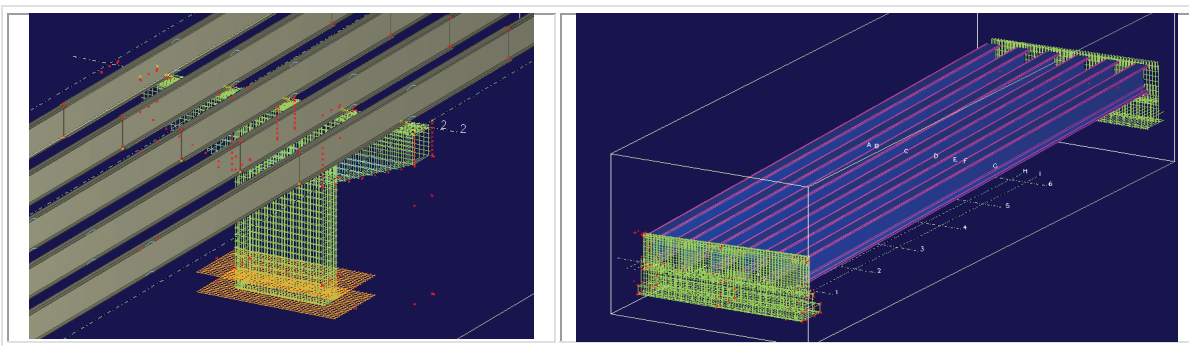

Figure 1

Portions of steel and concrete bridge models.

SMART ARRAY ANTENNA FOR NONDESTRUCTIVE EVALUATION OF FIBER-REINFORCED POLYMER-WRAPPED CONCRETE BRIDGE MEMBERS

NCHRP-IDEA Project 109

Maria Feng [Tel.: (949) 378-8666, Fax: (949) 824-0187, Email: mfeng@newport sensors.com]
Newport Sensors Inc., Irvine, California

This project developed a nondestructive method for the condition evaluation of fiber-reinforced polymer (FRP) concrete bridge members using a smart antenna array to detect microwave signals (Figure 1). The system consisted of three modules: a controller and a power supplier, a transceiver, and array antennas with a feed network. The system was subjected to several modifications and refinements. An embedded single board computer with a data acquisition board was used as the controller. The power supply design was modified to minimize its size. The housing was also redesigned and a transceiver with several RF parts was assembled. Software for system operation and real-time data processing and image visualization was developed and integrated with the hardware. The software verified that the feed network was working well and the control parameters were correct. The software program controlled the parameters for the transceiver operation and beam scanning and could also diagnose the status of the system. The performance of the prototype was evaluated on a variety of concrete-FRP specimens. Debonds of various areas and gaps were artificially created between the FRP and concrete. The prototype was shown to be effective in detecting and even quantifying debonding at the concrete-FRP interface. Based on evaluation results, a final design of the smart antenna system was developed. The final report is available from the National Technical Information Service (NTIS # PB2007-107337).

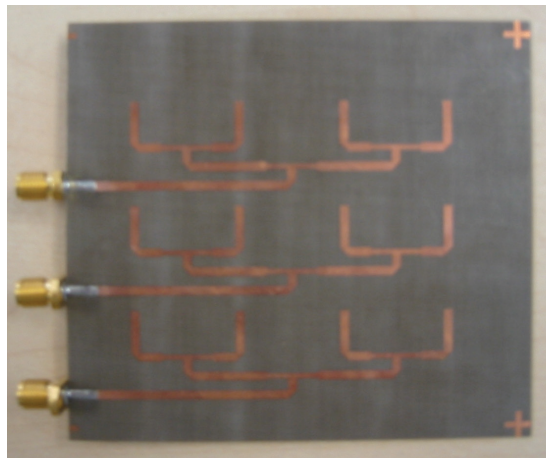

Microstrip feed

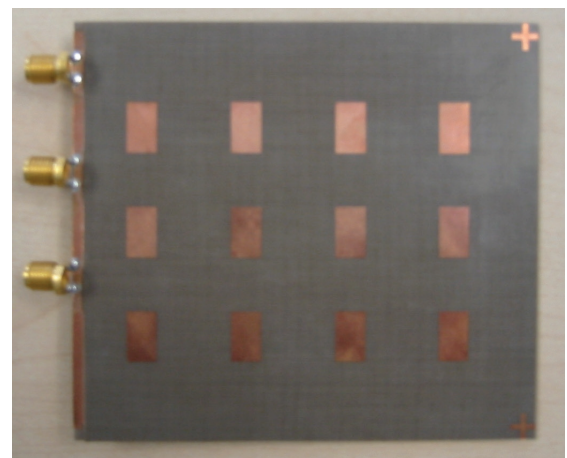

Patch

Figure 1

One of the six array antennas.

AUTOMATED PAVEMENT DISTRESS SURVEY THROUGH STEREOVISION

NCHRP IDEA Project 111

Kelvin C.P. Wang [Tel.: (479) 575-87425, Fax: (479) 575-7168, Email: kew@uark.edu]
University of Arkansas, Fayetteville, Arkansas

This follow-on project was aimed at refining and field testing a computer vision technique that was investigated in an earlier IDEA project (NCHRP-88) using multiple cameras for automated condition survey of highway pavements. A new vehicle for collecting digital highway data was procured, and four cameras were mounted in the rear of the vehicle to collect pavement surface images across a 4-m wide pavement. However, calibration work to correct camera distortion for 3D surface reconstruction showed the inadequacy of the Direct Linear Transformation (DLT) method for the purpose, and further work indicated that the Tsai method provided better accuracy than the DLT method. The space relationship between the two cameras also affected the calibration accuracy. While efforts were directed at improving the accuracy by adjusting each camera's angle and the space between the cameras, a new laser-based illumination imaging system was also investigated with promising results. Figure 1 demonstrates the working principles of the laser imaging system. The system allows image acquisition without the influence of sunlight or shadows, providing a 1-mm resolution of both longitudinal and transverse cracks at speeds up to 60 miles per hour. However, with the line-scan camera, the stereovision technology is not directly applicable and additional work is needed to establish the 1-mm level resolution of 3D pavement surface models with multiple laser imaging devices. The final report is available from the National Technical Information Service (NTIS # PB2008-106866).

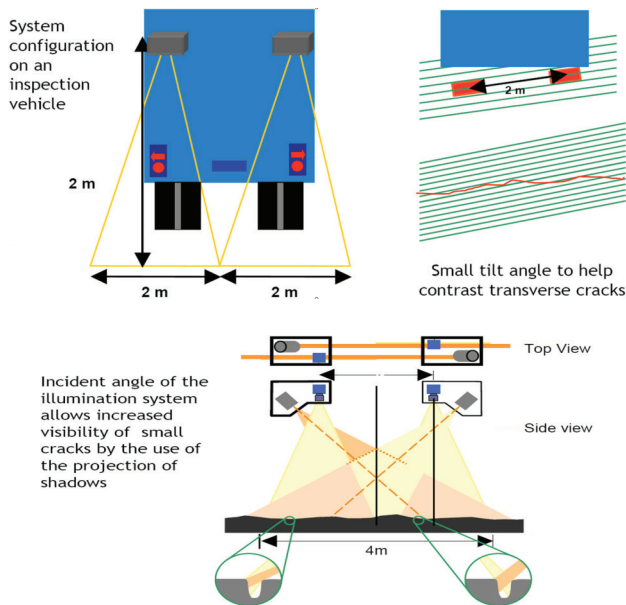

Figure 1

Working principle of the Laser Road Imaging System.

CONE PENETROMETER EQUIPPED WITH PIEZOELECTRIC SENSORS FOR MEASUREMENT OF SOIL PROPERTIES IN HIGHWAY PAVEMENT

NCHRP-IDEA Project 112

Xiangwu (David) Zeng [Tel.: (216) 368-2923, Fax: (216) 368-5229, Email: xxz16@cwru.edu]
Case Western Reserve University, Cleveland, Ohio

This project developed a mobile and robust cone penetrometer prototype with piezoelectric sensors (Figure 1) to measure soil properties in highway pavement. Sensors for the cone penetrometer were procured and tested, and the instrument design was modified to enhance its ruggedness and sensitivity. Software based on the theory of wave propagation in granular materials was developed for field data analysis. Laboratory tests on the system using two different types of soils, one fine-grained and the other coarse-grained, showed good results and repeatability for resilient modulus, shear modulus, and Poisson's ratio. The shear moduli of the soils agree well with that which was calculated by Hardin and Richard's equation. Work in the second stage focused on design improvement and field testing of the prototype equipment. Final design modifications to the prototype were made, and the equipment was fabricated. The modifications were aimed at making the equipment lightweight for easy handling and making the sensors waterproof to allow its use in wet soils. A vibration system was also introduced to help drive the penetrometer in the ground smoothly. The Ohio Department of Transportation provided a test site in Delaware County for field evaluation of the equipment. An equipment manufacturer is exploring commercialization of the instrument. The final report is available from the National Technical Information Service (NTIS # PB2007-107339).



Figure 1

The cone penetrometer equipped with piezoelectric sensors.

GEOCOMPOSITE CAPILLARY BARRIER DRAIN FOR LIMITING MOISTURE CHANGES IN PAVEMENTS

NCHRP-IDEA Project 113

John Stormont [Tel.: (505) 277-6063, Fax: (505) 277-1988, Email: jstorm@unm.edu]
University of New Mexico, Albuquerque, New Mexico

Karen Henry [Tel.: (603) 646-4188, Fax: (603) 646-4640,
Email: karen.s.henry@erdc.usace.army.mil]
US Army Cold Regions and Research Engineering Laboratory, Hanover, New Hampshire

Andrew Eller [Tel.: (651) 366-5524, Fax: (651) 366-5461, Email: andrew.eller@dot.state.mn.us]
Minnesota Department of Transportation, Minneapolis, Minnesota

This follow-on project evaluated and demonstrated the field application of a geocomposite capillary barrier drain (GCBD) technology developed in an earlier IDEA project (NCHRP-68) to improve pavement subsurface drainage. When placed between a base and subgrade, the GCBD can drain the unsaturated base and reduce its water content as well as prevent water from reaching the subgrade. In contrast to the GCBD, conventional drainage is designed for saturated flow, even though the positive pore water pressures required for saturated flow reduce strength and lead to rutting, heaving, and failure. The GCBD comprises three layers from top to bottom: a transport layer (a specially designed geotextile), a capillary barrier (a geonet), and a separator (geotextile). Figure 1 illustrates the principal function of the GCBD.

After selecting materials for the field test, developing a method for terminating the GCBD in an edge drain trench, and establishing specifications for field installation, a prototype GCBD was installed in a full-scale test section of MnRoad project. The MnRoad test data showed the pavement section with GCBD to be considerably drier compared to a control section. Falling weight deflectometer data from the section with the GCBD and the control section were compared, and design calculations for the performance of the GCBD in specific climate, geometry, and material properties were made. A geosynthetic manufacturing company in Atlanta, Georgia, has developed a new material that may work well as a transport layer in the GCBD configuration. (NTIS Report # PB2009-113226)

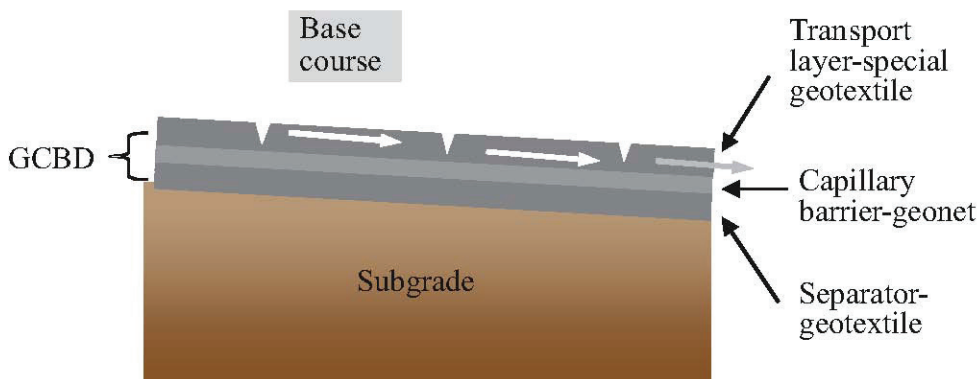

Figure 1

GCBD between base course and subgrade illustrating how water laterally drains in transport layer.

RELATIONSHIP OF ASPHALT PAVEMENT MICROTTEXTURE USING IMAGE ANALYSIS OF AGGREGATE SHAPE

NCHRP-IDEA Project 114

Eyad Masad, Texas A&M University [Tel.: (979) 845-8308, Fax: (979) 845-0278,

Email: emasad@civil.tamu.edu]

Department of Civil Engineering, Texas A&M University, College Station, Texas

This follow-on project further evaluated and refined a methodology based on the Aggregate Imaging System (AIMS), an image analysis technique developed in an earlier NCHRP-IDEA project (NCHRP-77) to measure and differentiate multiscale components of aggregate shape characteristics and to relate these characteristics to asphalt pavement microtexture and skid resistance. Initial efforts were focused on improving the image analysis methodology and identifying the shape scales that best correlated with aggregate resistance to polishing. The AIMS was used in conjunction with the Micro-Deval abrasion test to evaluate the aggregates' characteristics after different levels of polishing. Based on results, an empirical equation relating texture to time in the Micro-Deval was proposed. As a general trend, the texture and angularity of the aggregate decreased with an increase in time in the Micro-Deval machine. An evaluation of available skid data on Texas DOT test sections also showed a trend between aggregate type, mix type, and skid resistance. The asphalt pavement skid resistance also appeared to be related to aggregate average texture and the variability of texture within the aggregate source. A testing protocol for aggregate shape characteristics was also developed for aggregates commonly used in pavements.

As part of technology transfer efforts, the method developed under the NCHRP-IDEA project 144 was used to analyze more than 100 aggregate samples in Texas. The results were used to revise the Texas DOT classification of aggregates in order to improve the frictional resistance of asphalt pavements. The work is based on measuring the skid resistance of many asphalt pavements and measuring the texture of aggregates used in these pavements. Consequently, a large database will be available to classify aggregates based on their contribution to asphalt pavement skid resistance. AIMS was further evaluated and refined with support from FHWA's Highways for LIFE Program. The imaging system is now commercially available and is being used by FHWA for demonstration and training in its mobile laboratory. Two test procedures based on AIMS have been adopted by AASHTO for determining aggregate shape properties (TP 81 and PP 64). The final report is available from the National Technical Information Service (NTIS # PB2008 109819).

DEVELOPMENT OF A SECOND GENERATION DETECTION-CONTROL SYSTEM FOR SAFER OPERATION OF HIGH-SPEED SIGNALIZED INTERSECTIONS

NCHRP-IDEA Project 115

Karl Zimmerman [Tel.: (979) 458-2835, Email: k-zimmerman@ttimail.tamu.edu]

Texas Transportation Institute, College Station, Texas

This project improved and evaluated a detection-control system (D-CS) for enhanced traffic safety at high speed signalized intersections. Drivers approaching a traffic signal at high speed must decide whether to proceed or stop when presented with a yellow indication. This decision is based on each driver's perception of whether it is safe (or possible) to stop prior to entering the intersection. This decision is illustrated in Figure 1. A driver in the shaded area in Figure 1 is said to be in the "dilemma zone," where there is a range of driver reactions to the yellow indication. The Detection-Control System (D-CS), developed at the Texas Transportation Institute (TTI), was designed to reduce the likelihood of vehicles being in the dilemma zone. A literature review was conducted to identify potential enhancements to D-CS control algorithm required to create the "second generation" D-CS algorithm. The needed enhancements included dilemma zone protection based on vehicle size, real-time dilemma zone changes, coordination, and real-time measures of effectiveness reporting. After selecting the most feasible enhancements, the control algorithm was modified and tested in the laboratory. Based on laboratory test results, a "second generation" D-CS control algorithm was developed capable of providing dilemma zone protection specific to vehicle type using a modified system to prevent max out during "Stage 2" operation. The new algorithm showed improvement over the original algorithm and could provide real time information to engineers about intersection operation. The software was downloaded to intersections where D-CS had been installed during earlier field trials. At the first installation, it was discovered that shortening the D-CS protection zone to improve efficiency (the third installment) caused increased red light violation by vehicles. Therefore, prior to the second field trial, the third enhancement was removed from the enhanced control algorithm. The second trial was more successful as a result, indicating that the enhanced algorithm is successful at improving safety at isolated high-speed intersections. The final report is available from the National Technical Information Service (NTIS # PB2007-107338).

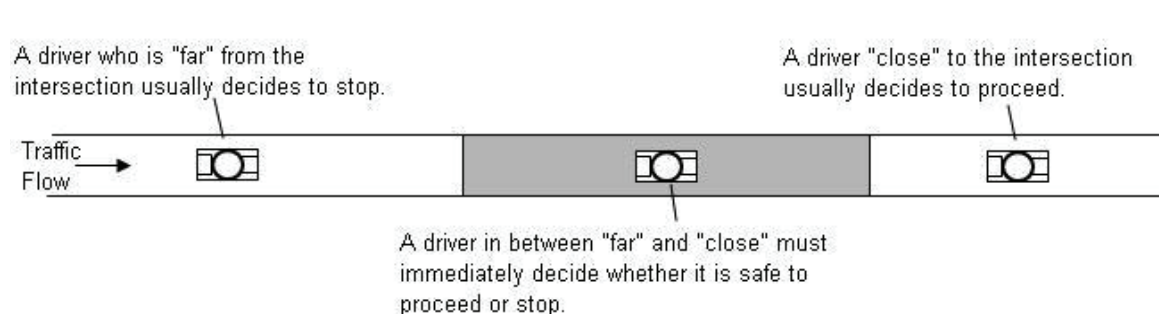

Figure 1

Driver decisions approaching an intersection.

SEISMIC RESPONSE OF BRIDGE COLUMNS WITH ENGINEERED CEMENTITIOUS COMPOSITES AND SHAPE MEMORY ALLOYS IN PLASTIC HINGE ZONE

NCHRP-IDEA Project 116

S. M. Sadrossadat-Zadeh [Tel.: (775) 784-4482, Fax: (775) 784-1390, Email: smsz@unr.edu],
and

M. Saiid Saiidi [Tel.: (775) 784-4839, Fax: (775) 784-1390, Email: saiidi@unr.edu]
University of Nevada, Reno, Nevada

This project evaluated the application of superelastic shape memory alloy (SMA) reinforcement in combination with engineered cementitious composites (ECC) in bridge columns to minimize earthquake damage. Based on initial evaluation, Nitinol SMA and ECC compositions were selected for application in bridge columns. An analytical study was performed to determine optimum material properties and configuration for the concrete column. Bridge columns incorporating a combination of SMA and ECC or conventional concrete were constructed and subjected to quasi-static cyclic tests. The first column (RSC) used conventional concrete and steel reinforcement; the other two, RNC and RNE, respectively, used conventional concrete with Nitinol and engineered cementitious composites (ECC) with Nitinol in the plastic hinge (Figure 1). The average ratios of residual to maximum displacement in RSC, RNC, and RNE were 0.82, 0.27, and 0.14, respectively, indicating the substantial benefits of using innovative materials. RNE experienced the least damage and highest drift capacity among the three columns. The test results showed the promise of SMA and ECC in improving serviceability of bridges after earthquakes. The final report includes important experimental and analytical data and provides design guidelines for improving the seismic response of bridge columns using SMA and ECC materials. The final report is available from the National Technical Information Service (NTIS # PB2007-109640).

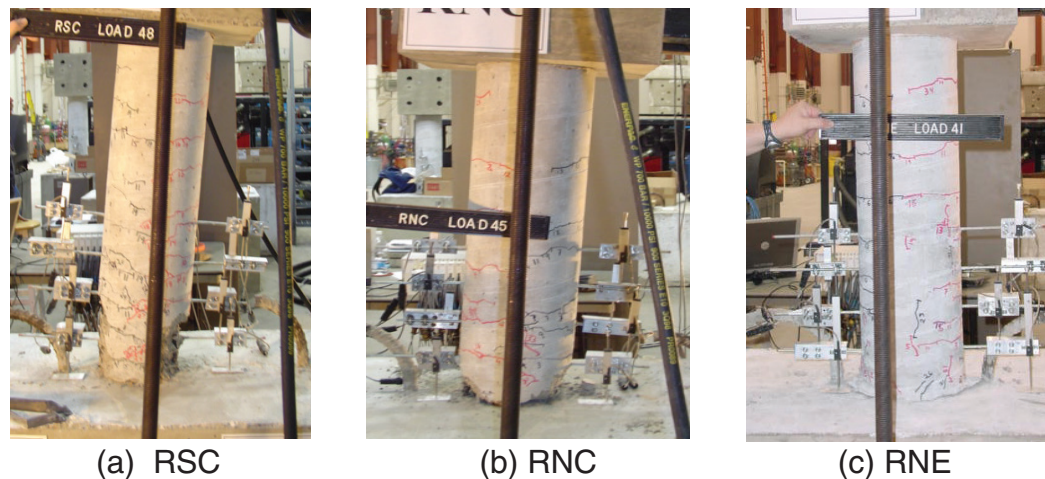

Figure 1

Residual displacement and damage after 10 percent maximum drift.

SELF-POWERED SENSORS AND ACTUATORS FOR BRIDGES

NCHRP-IDEA Project 117

Edward Sazonov [Tel.: (315) 268-3914, Email: esazonov@ieee.org or esazonov@clarkson.edu]

Pragasen Pillay [Tel.: (315) 268-6509, Email: pillayp@clarkson.edu]

Clarkson University, Potsdam, New York

Life-cycle monitoring of civil infrastructure, such as bridges, is critical to the long-term operational cost and safety of aging structures. Localized monitoring of bridge structural elements may require placement of a dense sensor array on the structure that would also require power. This project developed a micro-power electromechanical energy harvester and energy conversion unit for generation of electrical power from ambient vibration of bridges. Energy generated by the harvesting device powers wireless sensors that measure and wirelessly transmit bridge information, such as temperature and vibration, to a central location for analysis. A prototype linear generator was assembled, characterized, and tested in the laboratory and on a bridge (Figure 1). The prototype utilized a spring-mass approach. The stator was attached to a vibrating structure while spring stiffness was tuned to a resonant frequency of the bridge structure. An adaptive tracking algorithm to allow harvesting energy at the maximum power point was also developed. The electromagnetic energy harvester was integrated with energy conversion and storage circuitry and wireless sensor for testing on an actual bridge. The generator successfully harvested the bridge vibration energy to power the sensor. The self-powered wireless sensor technology was licensed to startup company AmbioSystems, LCC (www.ambiosystems.com). The research team is working in conjunction with AmbioSystems, New York State DOT, and other companies to bring self-powered sensors into practice. (NTIS Report # PB2008-113777)

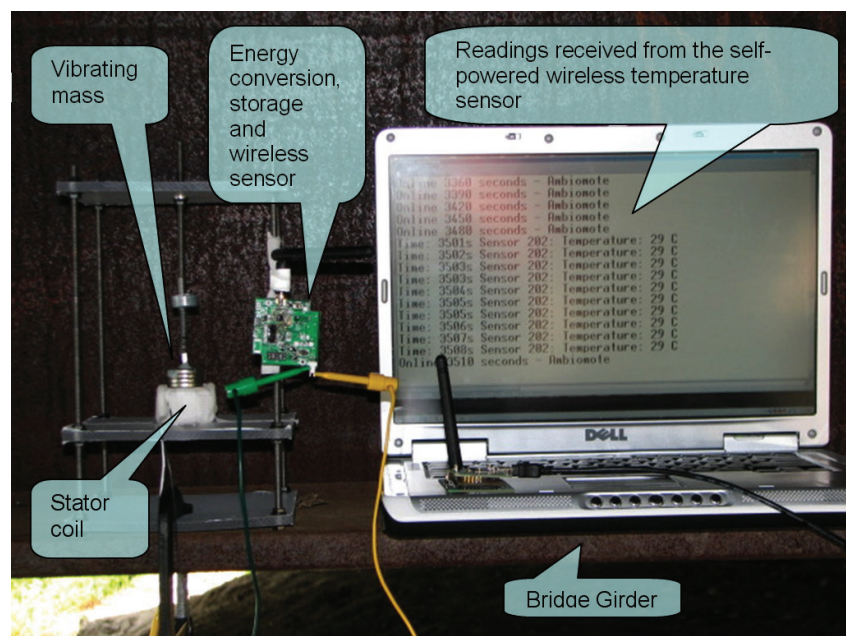

Figure 1

Prototype of the self-powered wireless sensor.

THE BCD: A NEW INSTRUMENT FOR COMPACTION CONTROL

NCHRP-IDEA Project 118

Jean-Louis Briaud and Keunyoung Rhee [Tel.: (979) 845-3795, Fax: (979) 845-6554,
Email: briaud@tamu.edu] Texas A&M University, College Station, Texas

This project developed and tested the Briaud Compaction Device (BCD), a portable device for measuring the soil modulus for compaction control in the field and establishing a target value in the laboratory (Figures 1 and 2). The BCD consists of a thin steel plate, 6 inches in diameter, at the bottom of a rod. When the operator leans on the rod handle, the plate bends and the strain produced in the plate is recorded. Use of a wet sand cushion between the plate and the soil significantly reduced the effect of an uneven surface and minimized variation in field test readings. Based on numerical simulations, the BCD can measure the modulus of soils in the range of 3 to 300 MPa and measure the modulus within a depth of influence of about 6 inches for a soil with a modulus between 5 and 100 MPa. Tests using a rubber block showed a linear relationship between the load applied on the BCD and the hoop strain recorded on the steel plate. Repeated testing on the same block showed very good repeatability of the test. Plate tests, performed in parallel with the BCD tests, showed good correlation between the plate and the BCD moduli. The diameter of the rod connecting to the plate was reduced to 1 inch to extend the range of the BCD to harder soils. A calibration procedure was developed using calibrated rubber blocks of known moduli; this allowed each BCD unit to be calibrated independently of the manufacturing variables. Resilient modulus tests and parallel BCD tests were performed in the laboratory on silty clay samples, 6 inches in diameter and 8 inches high, at various water contents. The data show a good correlation between the resilient modulus and the BCD modulus for different water contents for a given soil. The product is now commercially available, and several DOTs have already purchased it for further evaluation and implementation. The final report is available from the National Technical Information Service (NTIS # PB2009-113227).

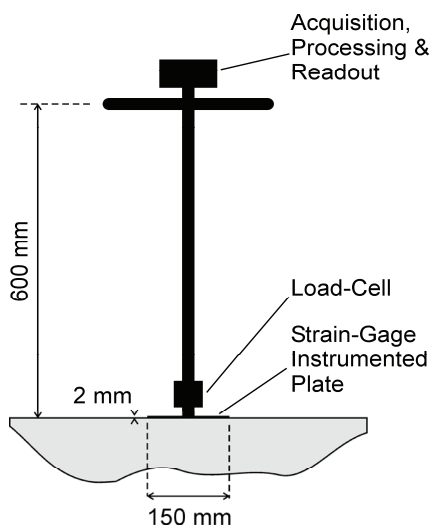

Figure 1
Conceptual Sketch of a BCD.



Figure 2
BCD-4.

THREE-DIMENSIONAL DIGITAL IMAGING FOR THE IDENTIFICATION, EVALUATION, AND MANAGEMENT OF UNUSABLE HIGHWAY SLOPES

NCHRP-IDEA Project 119

John Kemeny [Tel.: (520) 621-4448, Email: kemeny@spliteng.com, Web: www.spliteng.com]
Split Engineering LLC, Tucson, Arizona

James Donovan [Tel.: (801) 585-3029, Email: james.donovan@mines.utah.edu]
University of Utah, Salt Lake City, Utah

This project developed and field tested software for using ground-based LIDAR (also called 3D laser scanners) and digital imaging to analyze rockfall. This includes assessing rock faces for the likelihood of rockfall (rockfall ratings) and determining information on rockfalls that actually occur (rockfall locations, rate, and volume). Software development will be made through improvements to Split Engineering's Split-FX software for processing point clouds and associated digital images. Several sites were identified for field testing of the software, and LIDAR scans were conducted at locations where rock fall was likely to occur. The most important field site was a site chosen along Interstate 70 near Georgetown, Colorado where fatalities due to rockfall are known to occur (Figure 1). Further improvements to the software were made along with the incorporation of major features to the Split-FX program, including photo draping and the ability to extract fracture orientations from the 3-D photos, a change detection algorithm to detect and analyze the size and volume of rockfall, and a built-in rockfall hazard rating system to quickly and accurately evaluate rockfall and slope stability hazards. Additionally, Georgetown and Utah sites were rescanned to determine rockfall locations and volumes and the rockfall rating using the newly developed software. Also, a 'rolling rock' field test was conducted on Mount Lemmon, Arizona, to determine the smallest rockfall that could be detected and the overall accuracy and usefulness of the rockfall detection software. The product of this project is being further evaluated for implementation in a pooled-fund study supported by FHWA and eight state highway agencies. (NTIS # PB2010-101386)



(a)

(b)

Figure 1

LIDAR field site along Interstate 70 near Georgetown, Colorado, (a) rocky, steep rockfall source area above Interstate 70 and (b) Lidar scanning using an Optech scanner.

ACTIVE SENSING FOR ONLINE HIGHWAY BRIDGE MONITORING

NCHRP-IDEA Project 120

Hoon Sohn [Tel.: (412) 268-2077, Fax: (412) 268-7813, Email: hsohn@cmu.edu]
Carnegie Mellon University, Pittsburgh, Pennsylvania

This project developed a sensor-based nondestructive testing (NDT) method for online monitoring of highway bridges without using any past baseline data. The concept is illustrated in Figure 1. A theoretical framework of the proposed technique was developed along with a time reversal process (TRP) and an NDT methodology for detecting cracks in bridge steel girders. To prove concept feasibility, the following key questions were addressed: What is the practical sensing range of TRP for damage detection? Can different types of defects be selectively detected and quantified? Do sensor conditions affect damage detection? Do undesirable operational and environmental conditions affect damage detection? Is the proposed TRP applicable to more complex structural geometries? The sensing range of TRP was found to be significantly larger than that achieved by conventional NDT methods, and the active sensing device was able to propagate up to 40 m. Results also indicated that different types of defects could be distinguished, and adverse conditions, such as debonding and cracking of the sensing device, did not severely affect the TRP used for structural damage detection. Experiments also demonstrated that the technique was not significantly affected by (i) ambient temperature variations, (ii) imperfect sizing and positioning of the active sensing device, (iii) ambient background vibration of test specimens, (iv) changes in test specimen's boundary conditions, and (v) surface debris or additional paint layer on steel girders. Field tests at a steel bridge near Pittsburgh further established the robustness of the proposed approach against operational and environmental variations of the bridge. Further refinement of the technique is needed to address issues with automating data collection and interpretation and with hardware and transducer devices for long term continuous monitoring. The final report is available from the National Technical Information Service (NTIS # PB2007-109637).

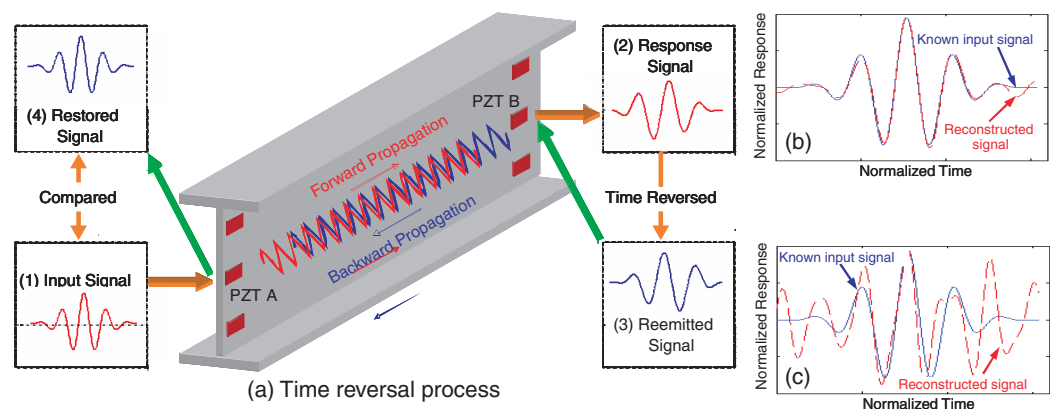

Figure 1

In the proposed baseline-free NDT, a time reversal process will be applied to crack detection within a steel girder: (a) a schematic sketch of time reversal process; (b) comparison between the original input signal (solid line) and the reconstructed signal (dotted line) before crack; (c) comparison between the original input (solid line) and the reconstructed signal (dotted line) after damage. Note that this method does not require any past baseline signals.

USING IMAGE PATTERN RECOGNITION ALGORITHMS FOR PROCESSING VIDEO LOG IMAGES TO ENHANCE ROADWAY INFRASTRUCTURE DATA COLLECTION

NCHRP-IDEA Project 121

Yichang (James) Tsai [Tel.: (912) 963-6977, Email: james.tsai@ce.gatech.edu]

Georgia Institute of Technology, Atlanta, Georgia

Collecting roadway infrastructure data, including roadway signs at each location is essential for asset management and for state departments of transportation (DOTs) to submit highway performance monitoring system data annually. Currently, this data collection is a manual process that is costly, time-consuming, and dangerous. This project developed an algorithm to automate sign inventory data collection and to make sign image recognition algorithms applicable for real-world video log images under different lighting, sign, and roadway conditions. The development was done in two parts: sign detection and sign recognition. A robust algorithm based on multifeature fusion was proposed for detecting signs. The algorithm performed both training and testing. In the training step, characteristics of MUTCD signs (including shape, color distribution, location distribution, and width-height ratios) in video log images were analyzed. For each feature, one or more sign detectors were designed, and their parameters (such as threshold values) were adjusted. Next, a sign recognition algorithm capable of classifying a variety of sign images was developed. This algorithm also consisted of training and testing steps and was tested with video log images collected on I-75 from Macon to Atlanta, Georgia, covering 140 km of rural and urban roadways. The algorithm successfully recognized 28 of 31 speed limit signs (a 90.3% recognition rate) and had only 5 false positives out of 136 speed limit sign images. With sufficient image training data sets, the proposed algorithm should also be applicable to other types of signs. The algorithms show a high promise for developing an intelligent sign inventory system that would help reduce the cost and time spent by state DOTs to acquire roadway infrastructure data through the use of video images. Louisiana and Georgia DOTs and the city of Nashville collaborated in this work and provided needed data for testing. Implementation of the IDEA product is under way through an FHWA-funded national demonstration project. The U.S. Coast Guard is exploring the technology for maritime applications. (NTIS Report # PB 2010-101387)

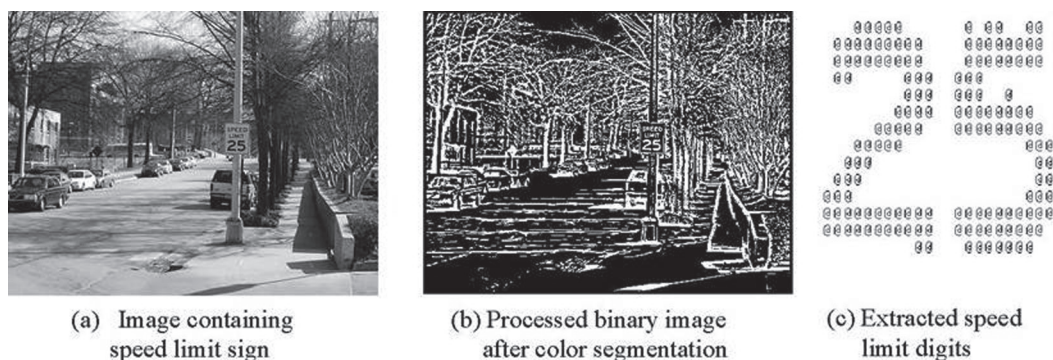

Figure 1

Speed limit sign extraction.

DIGITAL SPECIMEN AND MULTI-FUNCTION DIGITAL TESTER TECHNIQUE FOR PERFORMANCE EVALUATION OF ASPHALT MIXES

NCHRP-IDEA Project 122

Linbing Wang [Tel.: (540) 231-5262, Fax: (540) 231-7532, Email: wangl@vt.edu]
Virginia Polytechnic Institute & State University, Blacksburg, Virginia

Recent developments in x-ray computerized tomography (XCT) imaging and computational simulation have made it possible to characterize the properties of asphalt concrete through reconstruction of its three-dimensional (3-D) microstructure and computational simulation based on the 3-D microstructure. This project developed a 3-D digital representation of the microstructure of asphalt concrete and evaluated the performance of the 'digital specimen' using modeling and simulation techniques. A computer program to represent the microstructure of cylindrical specimens of asphalt concrete in digital format (digital specimen) was created, and modules to link the microstructure to a finite element code for simulating the indirect tensile test and dynamic modulus test (digital test) were developed (Figure 1). The simulation used elastic and viscoplastic material models for aggregate and asphalt respectively.

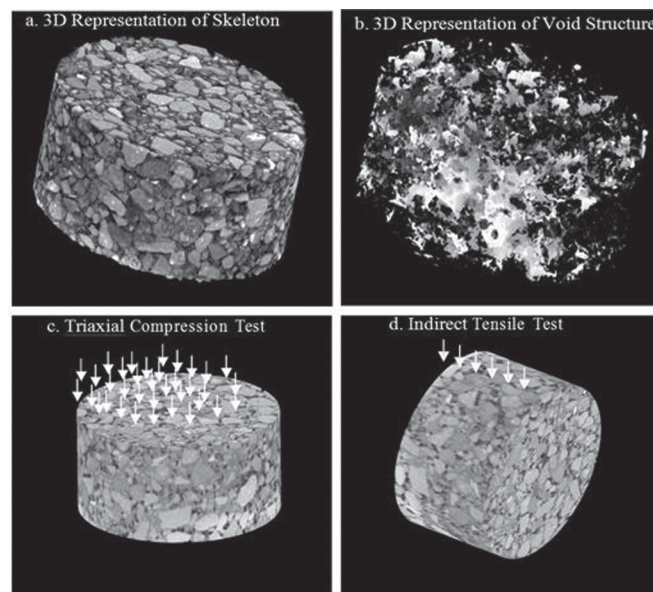

Figure 1

Illustration of the concepts of digital specimen and digital test.

By using rate dependent material model for asphalt binder, the numerical simulation of the indirect tensile test provided realistic response for asphalt mixture when compared qualitatively with experimental results. The model successfully captured stress variations due to both aggregates and voids, and the test was able to distinguish performance differences of different mixes. In addition, a set of compression tests on asphalt mixture specimens with different aggregate contents were conducted together with their digital counterparts. The actual and digital test results were in agreement at both microscopic and macroscopic levels. Additional development is needed before the digital specimen and digital test techniques can be implemented by highway agencies. (NTIS Report # PB2009-102139)

LONG-TERM REMOTE SENSING SYSTEM FOR BRIDGE PIERS

NCHRP-IDEA Project 123

Glenn Washer [Tel.: (573) 884-0320, Fax: (573) 882-4784, Email: washerg@missouri.edu]
University of Missouri, Columbia, Missouri

Paul Fuchs [Tel.: (703) 737-3871, Fax: (703) 737-6381,
Email: paul.fuchs@fuchsconsultinginc.com] Fuchs Consulting Inc., Leesburg, Virginia

Scour and other natural hazards have the potential to undermine the structural stability of highway bridges and the piers that support them. However, there remains a lack of reliable, cost-effective, long-term monitoring devices capable of determining the structural stability of bridge piers. This IDEA project developed a prototype tilt and displacement sensor (TDS) system for long-term remote monitoring of bridge piers. The system utilizes arrays of tilt sensors located on the pier and superstructure of a bridge to monitor long-term movements including tilt and vertical displacements (Figure 1). The system measures both changes in rotations (tilt) and vertical displacement of a pier, allowing for a more complete understanding of the behavior of the pier than is possible using currently available technologies. Following successful laboratory testing on a model pier, a fieldable system was developed and installed on an in-service bridge in upstate New York. Low-cost sensor arrays were installed on a central pier and on the superstructure of the bridge to evaluate tilt and vertical displacement of the pier over time. The online system is monitoring long-term motions of the pier and providing summarized, processed data over the web. The system results are being monitored to evaluate its performance and to assess the long-term displacements at the bridge. The system of sensors, data acquisition, and data processing algorithms comprise a commercial-ready product for monitoring bridge piers and other transportation structures. (NTIS Report# PB2011-105275)

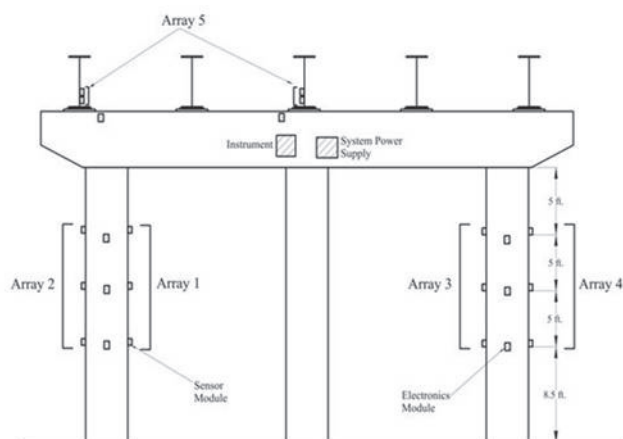

Figure 1

Schematic diagram of the tiltmeter system on a bridge in New York.

NOVEL OPTICAL FIBER SENSORS FOR MONITORING BRIDGE STRUCTURAL INTEGRITY

NCHRP-IDEA Project 124

Maria Feng [Tel.: (949) 378-8666, Fax: (949) 856-2082, Email: info@newportsensors.com]
Newport Sensors Inc., Irvine, California

This project developed a robust sensor system with high sensitivity based on novel integration of the moiré phenomena and fiber optics for monitoring bridge structural integrity. The system is easy to install and immune to electromagnetic interference and lightning strikes. With simple modification, the sensor can measure how a bridge responds to dynamic loads such as traffic acceleration, traffic displacement, and earthquakes. The measured structural vibration data then can be used to enhance the safety of highway bridges in real time by identifying structural damage and evaluating remaining capacity. The system's sensor head consisted of a pair of parallel grating panels, a pendulum, and two pairs of fibers with collimators (Figure 1). A special signal processing algorithm was developed to further broaden the dynamic bandwidth and enhance the measurement sensitivity of the accelerometer. A portable prototype multi-channel accelerometer system was also developed that included multiple sensor heads, a low-cost signal box (for sensor interrogation), and a PC (for signal processing). The system was tested in the laboratory and the field under a variety of dynamic excitations (including earthquakes). Two of the field tests were conducted at highway bridge sites under traffic excitations. The tests demonstrated superior performance of the new sensor system over its conventional electrical counterparts, including (1) total immunity to electromagnetic interference and lightning strikes, (2) high sensitivity and accuracy, (3) a large measuring range with particularly high performance in low frequencies, (4) a small sensor head with a lightweight optical fiber cable facilitating installation on long-span bridges, (5) robustness against environmental changes, and (6) a much lower cost than most optical fiber sensors. When integrated with the software system developed by the IDEA researchers, this sensor system can be easily installed on highway bridges for real-time structural health monitoring, post-event damage assessment, and capacity estimation. (NTIS Report # PB 2009-102139)

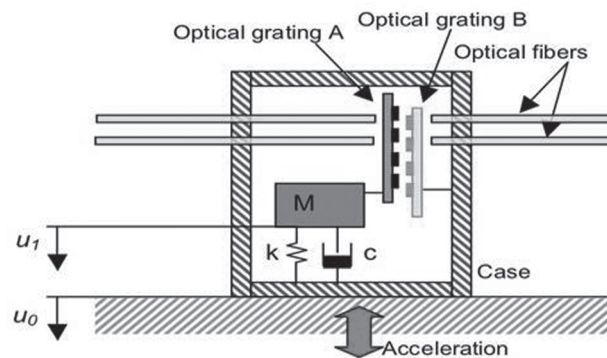

Figure 1

Design of fiber optic accelerometer.

AN AUTONOMOUS AND SELF-SUSTAINED SENSING SYSTEM TO MONITOR WATER QUALITY NEAR HIGHWAYS

NCHRP-IDEA Project 125

Xianming Shi [Tel.: (406) 994-6486, Fax: (406) 994-1697, Email: xianming_s@coe.montana.edu]
Western Transportation Institute, Bozeman, Montana

Monitoring water quality on a continuous basis is necessary for assessing the impact of highway runoff on bodies of water adjacent to highways. This project developed an autonomous and self-sustained sensing system for in-situ monitoring of environmental parameters (such as chloride, pH, dissolved oxygen, and temperature) in water bodies near highways (Figure 1). The system uses a novel microbial fuel cell (MFC) with a safe type of bacteria from the environment (*L. discophora*). After selecting sensors, communication devices, and a microcontroller and analyzing their voltage, current, and power requirements, an MFC was designed and tested under various conditions. Subsequently, an array of MFCs was built for preliminary testing, and improvements to the design of both the single MFC and the array of MFCs were made based on test results.

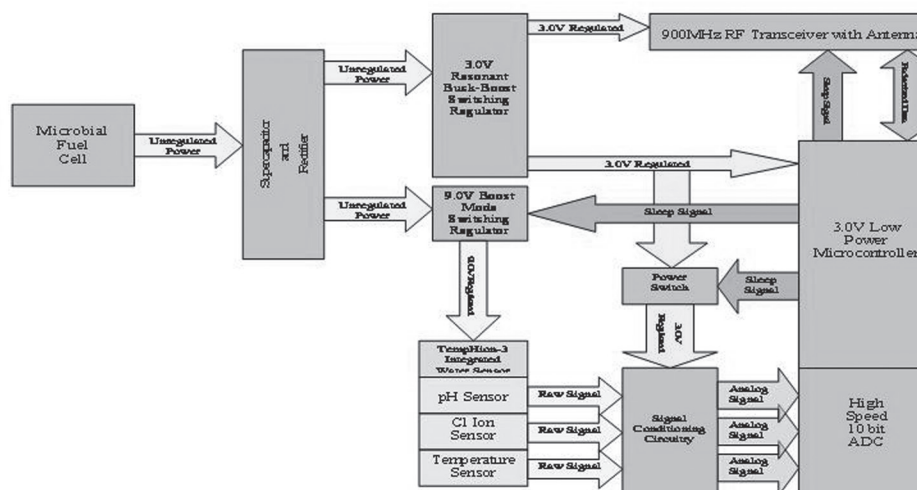

Figure 1

System block diagram

The system was tested in a local stream during varied weather conditions. The MFC array provided enough power to sustain circuitry function over a test period that included both temperature and sunlight fluctuations. The microcontroller successfully executed proper system functions based upon the measured output power of the MFC array. The data was transmitted on a 60 second interval over a period of several hours and was within acceptable tolerances for the chosen sensors. The system can save highway agencies time and labor by providing an efficient self-sustained tool to identify seasonal trends in real time for water quality parameters along highways, to assess the impact of various highway activities on water quality, and to evaluate the performance of various highway-runoff management practices over time. A patent for the technology was filed by Montana State University. (NTIS Report # PB 2010-112450)

DEVELOPING A TIME DOMAIN REFLECTOMETRY INSTRUMENT FOR FRESH CONCRETE AND EARLY-STAGE CONCRETE

NCHRP-IDEA Project 126

Xiong (Bill) Yu [Tel.: (216) 368-6247, Fax: (216) 368-5229, Email: xxy21@cwru.edu]
Case Western Reserve University, Cleveland, Ohio

This project developed a new instrument based on time domain reflectometry (TDR) for measuring properties of fresh and early-stage concrete as an alternative to traditional quality control methods that rely on slump value and compressive strength and do not always produce durable concrete. A prototype sensor system was designed (Figure 1) and tested on several concrete specimens used in highway construction. TDR signals were collected on concrete specimens subjected to different curing conditions, including early freezing, and the results were correlated with data obtained by standard test methods. The results indicated that the TDR sensor system could reliably measure or estimate concrete properties, such as free water content, density, air void content, initial and final setting times, and mechanical strength. New test results also showed promise of advancing this technology to estimate the thermal properties of concrete, such as the thermal conductivity and heat capacity. Experiments conducted on several soil types to verify the testing methodology provided promising results. The technology was found not only suitable to measure the physical and thermal properties of materials, but it also worked nondestructively under freeze-thaw cycles. Consequently, the system was refined to measure the thermal properties in nonintrusive fashion. The researchers received U.S. patents on the technology and on the flat strip design in addition to submitting several invention disclosures to the University. Durham Geo Slope Indicator, a manufacturer and distributor of engineering testing instruments, is interested in commercializing the developed TDR technology. (NTIS Report # PB 2010-112451)



(a)



(b)

Figure 1

(a) TDR package for field use (courtesy Durham Geo Enterprises);
(b) Example of laboratory experiment.

INSTRUMENTATION TO AID IN STEEL BRIDGE FABRICATION

NCHRP-IDEA Project 127

Paul Fuchs [Tel.: (703) 737-3871, Fax: (703) 737-6381,

Email: paul.fuchs@fuchsconsultinginc.com] Fuchs Consulting Inc., Leesburg, Virginia

The goal of this project was to develop a complete laser measurement system that would eventually eliminate the shop assembly process of steel bridges and provide a complete permanent record of the as-built condition of each girder. This system is built around an established commercial laser scanner and can provide features not found using any other commercial instrument or collection of instruments. The system measures girders in a fabrication shop, produces documentation, and can provide data to virtually assemble girders (Figure 1). The project work began with testing the proposed laser-based system in laboratory conditions. A three-week testing program was successfully completed at the Federal Highway Administration (FHWA) Turner-Fairbank Highway Research Center (TFHRC). These tests helped prepare the laser system and develop measurement algorithms for testing at a steel bridge fabricator. The system was then tested at a steel bridge fabricator's facility in Lancaster, Pennsylvania, where it was used to measure a pair of straight girders for a bridge job for the Maryland State Highway Administration. Data was taken on separate girder sections, fit virtually together, and compared to CAD shop drawings. Other curved girders and more complex structural shapes were also measured. The testing demonstrated the laser system's ability to work in a typical bridge fabrication shop environment. Several improvements in measurement algorithms and system configurations were identified. The research team is collaborating with the steel bridge fabrication industry to promote implementation of the system. A pooled-fund study involving several state DOTs is being planned to evaluate and implement the IDEA product. The final report is available from the National Technical Information Service (NTIS # PB2009-109001).

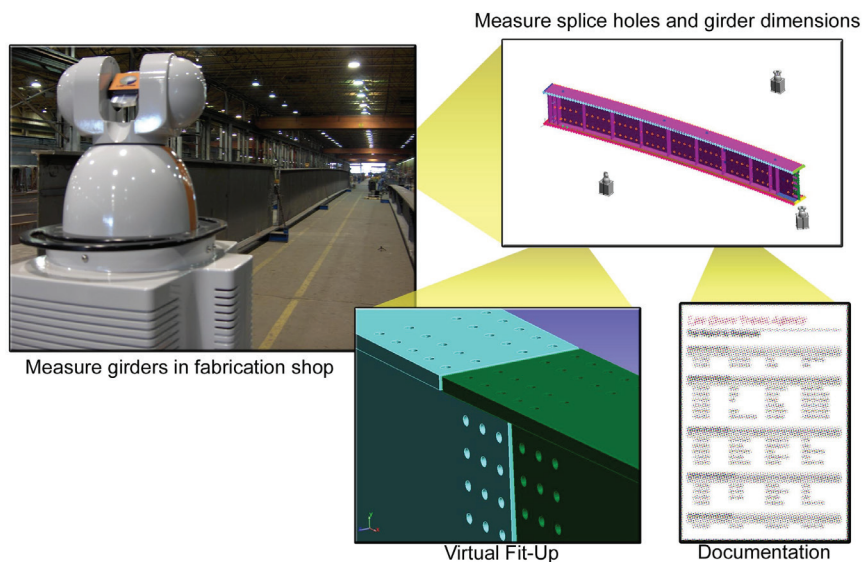

Figure 1

System concept for laser measurements of steel bridge girders.

UNDERWATER FIBER-REINFORCED POLYMER REPAIR OF CORRODING PILES INCORPORATING CATHODIC PROTECTION

NCHRP-IDEA Project 128

Rajan Sen [Tel.: (813) 974-5820, Fax: (813) 974-2957, Email: sen@eng.usf.edu]
University of South Florida, Tampa, Florida

Cathodic protection (CP) is a proven corrosion protection method for chloride-contaminated concrete; and the light weight, high strength, and corrosion resistance of fiber-reinforced polymer (FRP) make it the ideal repair material. This study incorporates CP within a bonded FRP repair to develop a new system that takes advantage of both technologies. This project developed and tested a hybrid FRP-CP system for the repair and corrosion protection of underwater piles. Initially, tests were performed on new systems that were developed to allow several partially submerged piles to be simultaneously pressure/vacuum bagged. Results from over 400 pullout tests showed that these new systems led to significant improvement in the FRP-concrete bond both above and below the waterline. Subsequently, the systems developed in the laboratory were implemented in the field. An embedded anode system was installed in four piles supporting the Friendship Trail Bridge in Tampa Bay in which the FRP wrap was pressure bagged (Figure 1). Preliminary results were found encouraging. However, several data loggers damaged by water intrusion were replaced and installed in a specially designed waterproof enclosure. Field monitoring of the CP system continues. The final report documents all data and developments of the FRP-CP system along with an assessment of the technology for implementation and commercialization. The capital costs for using pressure bagging systems and implementing embedded anodes are relatively small and are unlikely to be an important factor. (NTIS Report # PB 2010-112452)



Figure 1

Pressure bagging for enhancing FRP-concrete bond.

DEVELOPING AN EMBEDDED WIRELESS STRAIN/STRESS/TEMPERATURE SENSORS PLATFORM FOR HIGHWAY APPLICATIONS

NCHRP-IDEA Project 129

Kun Lian [Tel.: (225) 578-9341, Fax: (225) 578-6954, Email: klian@lsu.edu]
Louisiana State University, Baton Rouge, Louisiana

Zhongjie “Doc” Zhang [Tel.: (225) 767-9162, Fax: (225) 767-9108, Email: zzhang@dotd.la.gov]
Louisiana Transportation Research Center, Baton Rouge, Louisiana

This project developed and tested a radiofrequency (RF) wireless embedded sensor platform for monitoring material responses to traffic flow, such as deformation, pressure, temperature and acceleration inside asphalt, soil, and concrete structures. A prototype platform was designed that consisted of three main modules: sensor system, measurement/control/RF transmission, and Faraday/piezoelectric power harvesting devices (Figure 1). The sensor components were calibrated with the sensor control/RF data acquisition boards developed in the project and the calibration of strain sensors for asphalt and concrete material deformation was completed using MTS 810. The sensor was tested against measurements from a standard asphalt extensometer (Model 3910). The results showed that the strain sensor was able to measure accurately the asphalt strain level as a function of loading profile. It measured strain changes that matched results obtained from the conventional methods. Furthermore, the developed strain sensors met the asphalt strain measurement requirements with rapid enough response time. Similar strain calibration tests were also performed for concrete. The results showed that the embedded sensor had the same strain response behavior as the extensometer, suggesting that these sensors could reveal the true deformation behavior of concrete material under dynamic loading conditions. Additional work is needed before the system can be implemented in the field. (NTIS Report #PB 2011-114171)

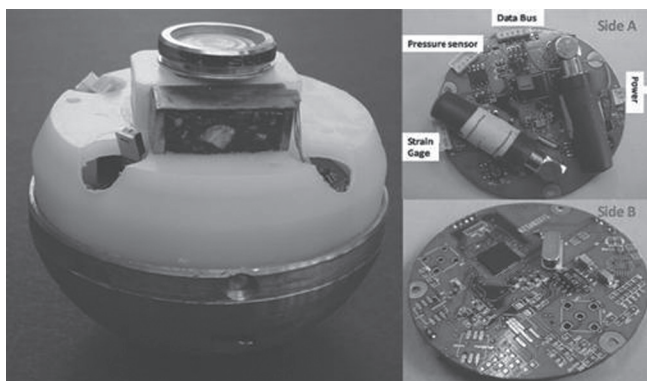

Figure 1

Prototype sensor platform with pressure, strain, acceleration, moisture, and temperature sensors integrated (left); the OEM RF control board (right).

RAPID, SELF-CONTAINED IN SITU PERMEAMETER FOR FIELD QC/QA OF PAVEMENT BASE/SUBBASE MATERIALS

NCHRP-IDEA Project 130

David J. White [Tel.: (515) 294-1463, Fax: (515) 294-8216,

Email: djwhite@iastate.edu] Iowa State University, Ames, Iowa

Recent studies show the coefficient of variation of in-situ permeability to be as high as 50 to 400 percent, making base/subbase permeability the most variable engineering parameter in the pavement system. This project developed an automated in situ permeability test (APT) based on a gas-pressurized system that takes less than 30 seconds per test location, allowing for statistical/spatial analysis of the results (Figure 1). Spatial maps of the in situ permeability can be used as field QC/QA criteria for pavement base/subbase to identify field problems such as segregation and particle degradation. Comparison permeability measurements demonstrated that the APT was within one order of magnitude of laboratory and another in-situ permeameter test device that use water. Measurements at test sites on US 63 in Iowa, I-94 in Michigan, and US 22 in Pennsylvania indicated strong correlations between APT measurements and fines content. The use of in situ permeability measurements will allow greater precision in the design, construction, and field QC/QA of pavement bases/subbases. It could also reduce over-design or improve long-term performance due to improved quality control of the drainage layer and, specifically, uniformity. Other applications of the device include measuring the permeability of pervious concrete materials and stabilizing open-graded drainage layers and hot-mix asphalt joints. (NTIS Report # PB2011-100029)

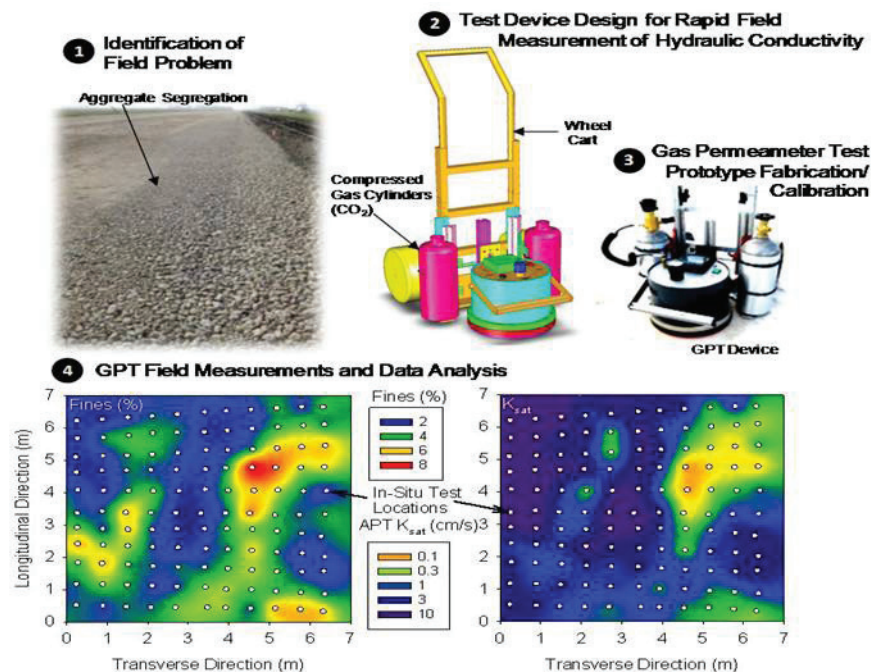

Figure 1

Primary steps involved in the development and validation of the gas permeameter test device.

SMART SENSOR FOR AUTONOMOUS NOISE MONITORING

NCHRP-IDEA Project 131

Douglas Meeġan [Tel.: (303) 795-8106, Fax: (303) 795-8159, Email: dmeeġan@ara.com]
Applied Research Associates Inc., Littleton, Colorado

This project developed a low-cost sensor system for autonomously monitoring and wirelessly reporting highway traffic noise data. The smart sensor for autonomous noise monitoring (SSAM) reports noise measurements periodically (for example, hourly, daily, or as desired) to a receiver located up to 1.2 miles away. The technology incorporates embedded processing software developed to provide capability to measure sound in averaging modes, apply frequency weightings, and compute octave band analyses consistent with ANSI standards for Type 1 ratings. The sensor enclosures are readily mounted to a simple post or tripod and wireless transmission ranges of more than 1 mile were demonstrated through controlled testing. Working with Ohio DOT, a total of 20 SSAM systems were tested. In field tests, 16 SSAM units operated simultaneously and transmitted noise data wirelessly. The field work included noise barrier testing for the Ohio DOT and wayside measurements (statistical pass-by) for California DOT. The developed prototype hardware was capable of performing low-cost noise monitoring at several locations simultaneously with wireless data transfer to a remote base station. The sensors are expected to cost less than \$100 each (in large quantities), making them cost-effective to monitor many locations simultaneously (Figure 1). The SSAM is now available for demonstration or use in noise studies. (NTIS Report # PB 2010-115380)

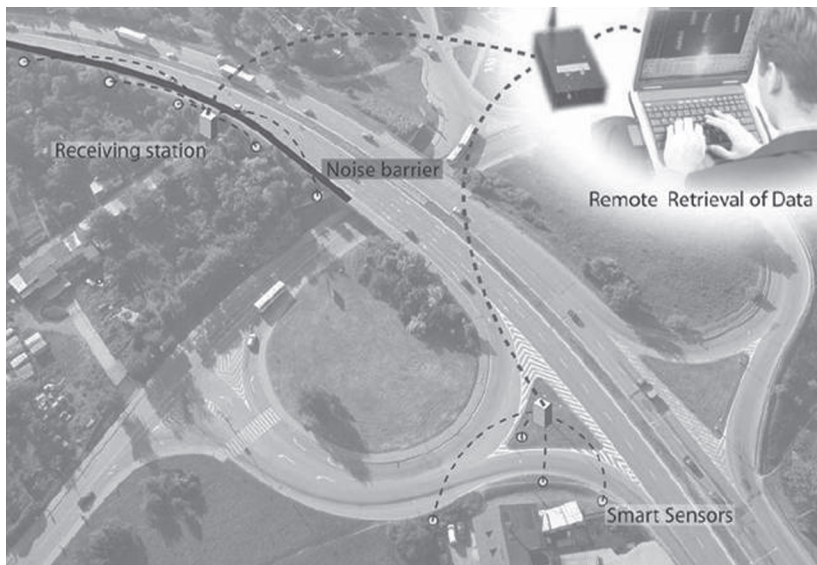

Figure 1

General concept of operation of a network of wireless smart sensors for autonomous noise monitoring.

VEHICLE-MOUNTED BRIDGE DECK SCANNER

NCHRP-IDEA Project 132

Yajai Tinkey and Larry D. Olson [Tel.: (303) 423-1212, Fax: (303) 423-6071,
Email: yajai@olsonengineering.com] Olson Engineering Inc., Wheat Ridge, Colorado

This project developed a vehicle-mounted bridge deck scanner (BDS) system based on non-destructive evaluation (NDE) technologies for the rapid and quantitative internal evaluation of reinforced concrete bridge decks, using a combination of the impact echo (IE), automated acoustic sounding, spectral analysis of surface waves (SASW), and slab impulse response (SIR) methods. This research explored and implemented rolling contact and noncontact transducers used by all four test methods in the BDS. The final product was a vehicle-mounted prototype system with multiple rolling contact sensors and/or airborne noncontact transducers with different types of sources to perform IE, automated sounding, SASW, and SIR tests. The BDS system was easily attachable and detachable from any vehicle (e.g., from the ball on a truck hitch). Results from the four NDE test methods address different aspects of the internal conditions of concrete decks. Attaching the BDS system to a vehicle during scans expedites the field-testing process and allows near-continuous testing along the bridge deck by the BDS system. The prototype was tested in Wyoming on Douglas Bridge in Douglas and the bridge on First Street in Casper to determine bridge deck conditions along with other traditional evaluation methods, such as ground penetrating radar, impact echo (point by point) and infrared thermography, for comparison. The tests showed excellent results from the rolling IE component (the sensor and impactor wheel). The delamination map of the bridge deck obtained from the impact echo wheels and the chain drag results also showed good agreement. (NTIS Report # PB2011-100030)

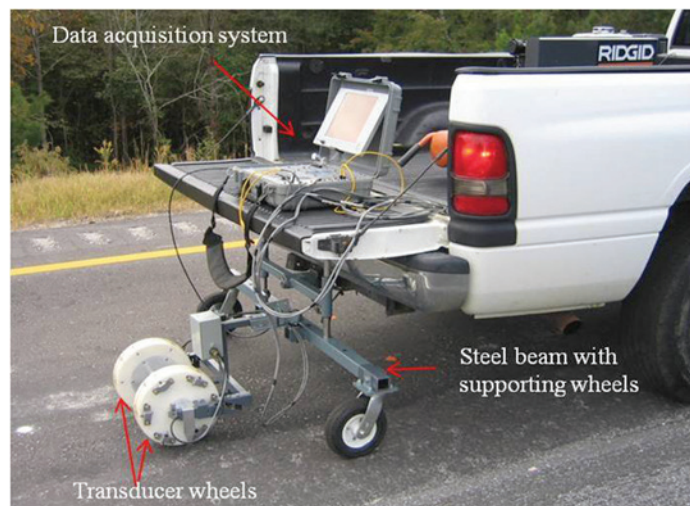

Figure 1

Bridge deck scanner (BDS) prototype.

DEVELOPMENT OF A SIMPLE TEST TO DETERMINE THE LOW-TEMPERATURE CREEP COMPLIANCE OF ASPHALT MIXTURES

NCHRP-IDEA Project 133

Mihai Marasteanu [Tel.: (612) 625-5558, Fax: (612) 626-7750, Email: maras002@umn.edu]
University of Minnesota, Minneapolis, Minnesota

Good fracture resistance is critical for asphalt pavements in cold regions where the predominant failure mode is low-temperature cracking. The current Superpave specifications for asphalt binders and mixtures address thermal cracking through the use of strength and creep tests. This IDEA project developed a simple bending creep test as a rapid, convenient, and versatile alternative to the tedious and time-consuming indirect tension test (IDT). The new test uses thin beams of asphalt mixtures and is performed on the bending beam rheometer (BBR) currently used as part of the asphalt binder performance grading specifications (Figure 1). A methodology for sample preparation and testing was developed. Thin mixture beams were cut using a simple tile saw. The loading protocol of the existing bending beam rheometer (BBR) device was modified to accommodate higher load levels. The simplest test method avoided testing at low temperature levels and predicted creep stiffness from data obtained at higher temperatures. The current AASHTO standard for IDT and the proposed BBR test method were followed to perform creep tests on laboratory prepared asphalt mixtures and cored field samples. The results indicated that IDT and BBR creep compliance are slightly different, but tests on homogenous polymer specimens showed no significant differences. Additional tests on asphalt mixture beams of different sizes gave similar creep stiffness results suggesting that the differences between IDT and BBR results are due to sample geometry effects and testing artifacts. Based on composite materials models and finite element method simulations, a back calculation procedure was developed to obtain asphalt binder creep compliance from mixture experimental data. Based on the IDEA work, a method for determining the flexural creep stiffness of asphalt mixtures using the bending beam rheometer was drafted for review by AASHTO. Utah and Minnesota DOTs have expressed interest in implementing the test method as part of their routine testing program. (NTIS Report # PB 2010-101388)

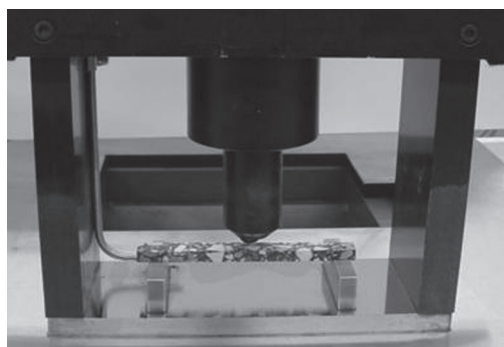

Figure 1

Bending Beam Rheometer (BBR) with thin asphalt mixture.

INVESTIGATION OF A FULL-LANE ACOUSTIC SCANNING METHOD FOR BRIDGE DECK NONDESTRUCTIVE EVALUATION

NCHRP-IDEA Project 134

John S. Popovics [Tel.: (217) 244-0843, Fax: (217) 265-8040,

Email: johnpop@illinois.edu] University of Illinois, Urbana-Champaign, Illinois

Alex Gibson [Tel.: (+61) 0437 159 774, Fax: (+61) 8 9467 9172,

Email: alex@chased.com.au] Chased Technologies Pty Ltd., Perth, Australia

Of the nearly 600,000 bridges in the United States, 27 percent were rated as structurally deficient or functionally obsolete in 2003. Timely renewal of service life is facilitated if rapid, accurate, and reliable nondestructive scanning technologies are applied to assess various transportation infrastructure components (such as bridge decks) with minimal disruption to structure service. This project developed an acoustic scanning method for nondestructive condition evaluation of bridge decks. The prototype included data acquisition and analysis hardware and noncontact sensors, and its design considered issues such as impact source type, trigger mechanism, background noise, rolling vibrations, spatial tracking and mapping, and self-contained power source, among others. The prototype was further optimized in terms of sensor type and source sensor configuration, and its performance was confirmed by preliminary experimental tests carried out on a controlled reinforced concrete slab that contained artificial delamination defects. Two sets of delaminations were cast at two different depths: approximately 1 in. and 2 in. in the test slabs. The delaminations varied in size to represent a wide range of delamination defects in terms of area, angle, and depth-to-size ratio. The delamination defects were simulated by a double-layer of polyethylene sheeting cut to appropriate size. Air-coupled impact-echo data collected across the test slab unambiguously and accurately identified the locations of all defects. Technical problems with the rolling impactor system were principally caused by the rough surface of the pavement site. This issue and the field robustness of the system need to be addressed before the system can be implemented in the field. (NTIS Final # PB2011-105276)

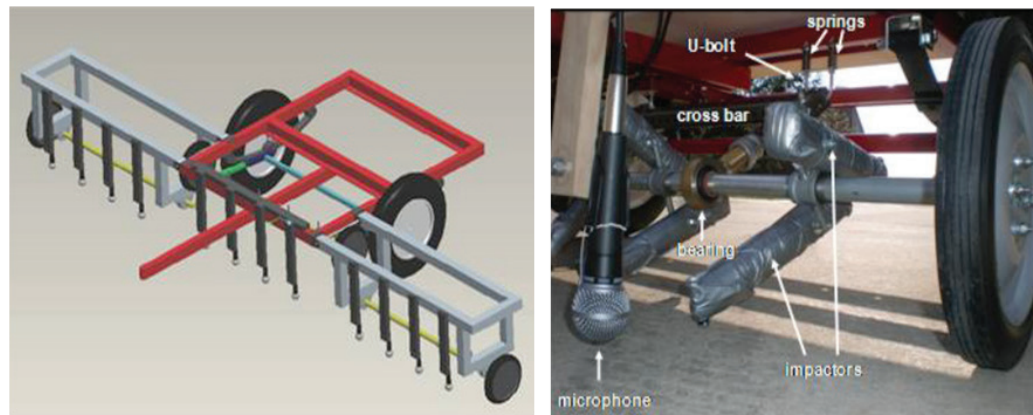

Figure 1

Area scan trailer prototype: concept of testing configuration (left) and photo showing detail of excitation axle and sensors (right).

ACTIVE CONFINEMENT OF BRIDGE PIERS USING SHAPE MEMORY ALLOYS

NCHRP-IDEA Project 135

Bassem Andrawes [Tel.: (217) 244-4178, Fax: (217) 265-8039,

Email: andrawes@illinois.edu] University of Illinois, Urbana-Champaign, Illinois

This project developed a system for the active confinement of reinforced concrete bridge piers using shape memory alloys (SMAs). A material testing program determined the stress-strain behavior of concrete cylinders actively confined with SMAs. Figure 1 illustrates the procedure for applying active confinement on bridge piers using SMAs and one of the SMA retrofitted columns that was tested in this project. The approach is expected to facilitate the application of active confinement and provide a more desirable retrofitting method, which would enhance the performance of reinforced concrete bridges during earthquakes. SMA spirals were evaluated for their thermo-mechanical characteristics and effectiveness in enhancing the concrete compressive strength and ductility. Recovery stress of the SMA wires and its stability at various ambient temperatures was also examined. The tests revealed a reliable behavior for the SMA wires, which were able to develop a recovery stress of 75 kip per square inch that was stable at room temperature. A series of concrete compression tests were conducted to compare the effectiveness of the SMA spirals with glass fiber-reinforced plastic (GFRP) wraps. Results showed that the SMA spirals increased the concrete ultimate strain (ductility) by 24 times as much as unconfined concrete. The behavior of the SMA-confined concrete was much superior to GFRP-confined concrete. In quasi-static lateral cyclic tests on reduced-scale reinforced concrete circular bridge columns, SMA spiral-wrapped columns were able to sustain 12 percent drift ratio with no significant signs of damage, while the GFRP wrapped column started experiencing major damage starting at 4 percent drift ratio. The new SMA spirals/wraps product could be easily installed and removed in bridges without the need for adhesive material between the columns and the spirals and with minimal labor and hardware. Using active confinement will increase the ductility capacity and shear strength of bridge piers and hence reduce the extent of damage sustained by the piers during strong earthquakes. This would make bridges more resilient to earthquakes and enhance their functionality after major seismic events. (NTIS Report # PB2011-105277)

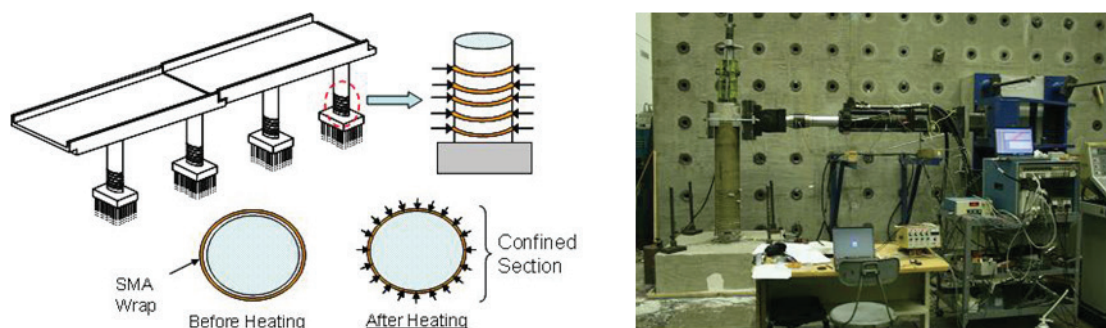

Figure 1

Schematic illustrating the concept of using SMA wraps for the retrofitting of bridge columns (left) and a picture of SMA wrapped concrete column during testing (right).

DEVELOPMENT OF A SECOND GENERATION NEUTRON-BASED DETECTOR FOR CHLORIDE IN CONCRETE

NCHRP-IDEA Project 136

Mohamad Al-Sheikhly [Tel.: (301) 405-5214, Fax: (301) 314-2029;

Email: mohamad@umd.edu] University of Maryland, College Park, Maryland

The project was undertaken to develop and test a neutron-based detector system for detecting and measuring chloride in in-service concrete (Figure 1). The nondestructive test method is based on prompt gamma neutron activation (PGNA). Neutrons from a portable source are used to irradiate the concrete structure. The neutrons are captured by atoms in the material, and in this process gamma rays are emitted with characteristic energies. The gamma rays travel out of the concrete and are then counted by detectors. The size of each gamma ray peak in the spectrum is proportional to the concentration of the element in the concrete. The original work plan involved three stages: 1. Numerical modeling and simulations to optimize the design of the system; 2. Instrument assembly and calibration in the laboratory on test specimens with known chloride concentrations; and 3. Field testing on actual concrete bridges. Work on the design calculations (Stage 1) was satisfactorily completed. This consisted of specifying the dimensions of the planar gamma ray detector, selecting the type of neutron generator, and modeling the moderator using the Monte Carlo N-Particle (MCNP) software. However, a major obstacle to the completion of Stages 2 and 3 was the lack of a thermal neutron source in the timeframe of this project. The nuclear reactors at the University of Maryland and at the National Institute of Standards and Technology (NIST) were not operable. Consequently, most of the work proposed in Stage 2 of the original work plan, which involved calibration of the system in the laboratory, could not be accomplished. Still, some experimental investigations were carried out using radio-isotope gamma ray sources, which confirmed the principle of electronic collimation and verified the improved directionality of the system. In addition, experiments using the cold neutron PGNA station at NIST provided data that can be used to estimate the performance of a portable field PGNA system. A number of state departments of transportation have expressed interest in using the PGNA system when it becomes available. Current plans are to continue the research on laboratory testing of the system using the portable neutron generator at NIST. (Final Report NTIS # PB2016-100666)

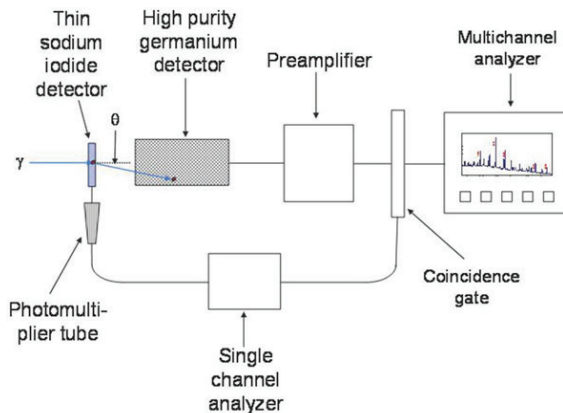

Figure 1

Schematic diagram of the HPGe gamma-ray detector in the electronic collimation configuration.

REAL-TIME REMOTE EVALUATION OF POST-EVENT RESIDUAL CAPACITY OF HIGHWAY BRIDGES

NCHRP-IDEA Project 137

Maria Feng [Tel.: (949) 378-8666, Fax: (949) 856-2082, Email: info@newportsensors.com]
Newport Sensors Inc., Irvine, California

Lack of rapid information about the post-event structural integrity of bridges can cause safety hazards to the traveling public, halt mobility of the transportation network, and disrupt emergency response. The current practice relies mainly on visual inspection for damage detection, which is time consuming and requires physical presence of inspection crews on a structure that is potentially hazardous after events such as earthquakes, hurricanes, and terrorist attacks. This project developed and demonstrated the application of a baseline-free monitoring methodology for real-time assessment of post-event integrity and safety of highway bridges. The method is illustrated in Figure 1. Four different methods were developed for post-event bridge structural damage assessment based on vibration responses measured during the event and structural stiffness and damping identification and validated through seismic shaking table tests of a large multi-span concrete bridge model. One of the methods was based on nonlinear damping and the others on structural stiffness identification. The damping method performs quick damage screening. If damage is detected, a more detailed assessment is carried out based on structural stiffness analysis, which identifies damage locations and extents. Based on measured bridge dynamic responses, changes in structural stiffness were identified and the occurrence, locations, and extents of structural damage assessed. These damage assessment results were used to develop a method to estimate the post-event remaining capacity of a bridge. The identified post-event structural stiffness was used to update the structural model for push-over analysis to allow determination of the remaining capacity of the bridge. The methods for post-event damage assessment and capacity estimation were packaged into efficient computer algorithms and into an exploratory software package named "Bridge Doctor." The software was integrated with an instrumented test bed bridge in California for long-term performance evaluation and demonstration. The software is capable of rapid damage screening, detailed damage assessment, and remaining capacity estimation, and it can serve as a useful tool to assist decision making in post-event bridge operations and repair/retrofit. (NTIS Report # PB2011-105278)

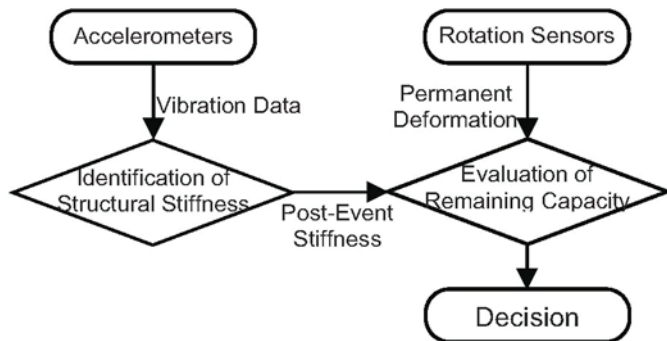

Figure 1

Proposed damage assessment and capacity estimation method.

SCANNING CAPACITIVE ARRAYS FOR REAL-TIME, IN-SITU IMAGING OF DENSITY AND THICKNESS IN HMA ROADWAYS

NCHRP-IDEA Project 138

Yanko Sheiretov [Tel: (781) 642-9666 Fax: (781) 642-7525 E-mail: jentek@shore.net]
JENTEK Sensors, Inc., Waltham, Massachusetts

Hot-mix asphalt (HMA) density is one of the best predictors of pavement quality and durability. The goal of this project was to develop a method for measuring HMA density via an array of sensors capable of rapidly inspecting large areas (Figure 1). Research performed in the project demonstrated desired measurements with a working prototype. The prototype sensor was designed to be one element of the multiple-element sensor array. It was about 2.5 inches high, had an active element length of 12 inches, and was equipped with wheels. The active area of the sensor included electrodes for generating the electric field (drive electrodes) and four sets of sensing electrodes, sensitive to material properties at varying depths (patents issued and pending). In the demonstration, this prototype sensor was used to scan four 1.5 inch thick lab-produced Superpave HMA-lift specimens (two at about 86% density and two at about 91% density). Data from two sensing electrodes acquired at 10 MHz were used to estimate the effective dielectric permittivity of the HMA specimens, using Jentek multivariate inverse methods. The estimated permittivity exhibited strong correlation with the HMA density, and the measurements were repeatable. The prototype sensor is designed to be a part of a 19-sensor array—enabling rapid, wide, detailed, full coverage of a 10-foot-wide scan path. Jentek's parallel-architecture 39-channel instrument can simultaneously acquire single-frequency data from all sensors in the array at a rate higher than 100 measurements per second. Additional work is needed to transition this prototype to a commercial product. (NTIS Report # PB 2010-112453)

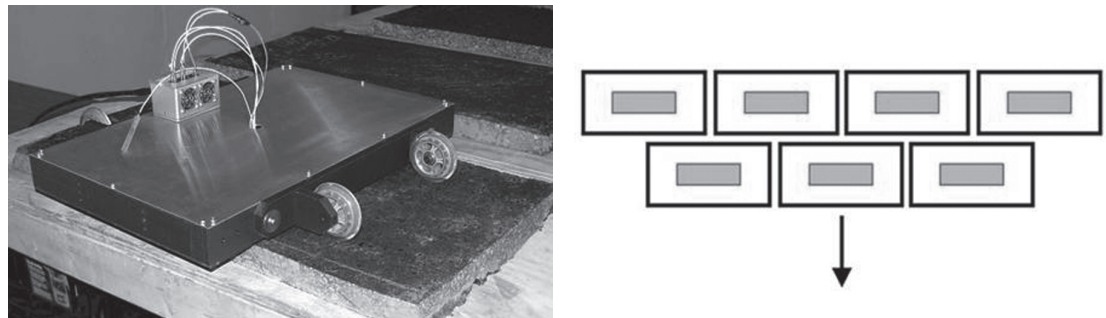

Figure 1

Prototype rolling capacitive HMA density sensor atop an HMA slab (left) and schematic of seven such sensors in a staggered array designed to be rolled down a roadway to generate a rapid image (right).

DEVELOPMENT OF A SENSING METHODOLOGY FOR INTELLIGENT AND RELIABLE WORK-ZONE HAZARD AWARENESS

NCHRP-IDEA Project 139

Yichang (James) Tsai [Tel.: (912) 963-6977, Email: james.tsai@ce.gatech.edu]

Georgia Institute of Technology, Atlanta, Georgia

The project developed a vision-based sensing methodology that has two features: (1) It can detect a vehicle intruding into work-zone areas and provide early warning to improve safety of workers; and (2) it can detect missing work-zone channelization traffic control devices (e.g., cones) to ensure the safety of drivers and workers, and to prevent lawsuits against state departments of transportation. The objective was to maximize the detection of potential work-zone hazards without excessively triggering false alarms. Figure 1 shows how a protection zone with the proposed awareness system could be established by using an intelligent vision and sensing system. The system could be located behind the barrel taper or along the shoulder.

The system was developed in four steps. In the first step, a reliable vehicle detection, recognition, and tracking algorithm was developed. This algorithm provided accurate computation for minimizing false negative and false positive rates. In the second step, a vehicle trajectory and intrusion likelihood (e.g., safe, cautious, and dangerous) analysis algorithm was developed to track all approaching vehicles and their intrusion likelihood. In the third step, a work-zone hazard decision-support model was established, based on the vehicle intrusion likelihood for each approaching vehicle to determine the adequate timing to trigger an alarm. In the final step, a surveillance system, including a 30-ft surveillance tower and cameras, was developed and successfully tested on an actual pavement resurfacing work zone on I-95 near Savannah, Georgia. The final report is available from the National Technical Information Service (NTIS Report # PB2012-110781).

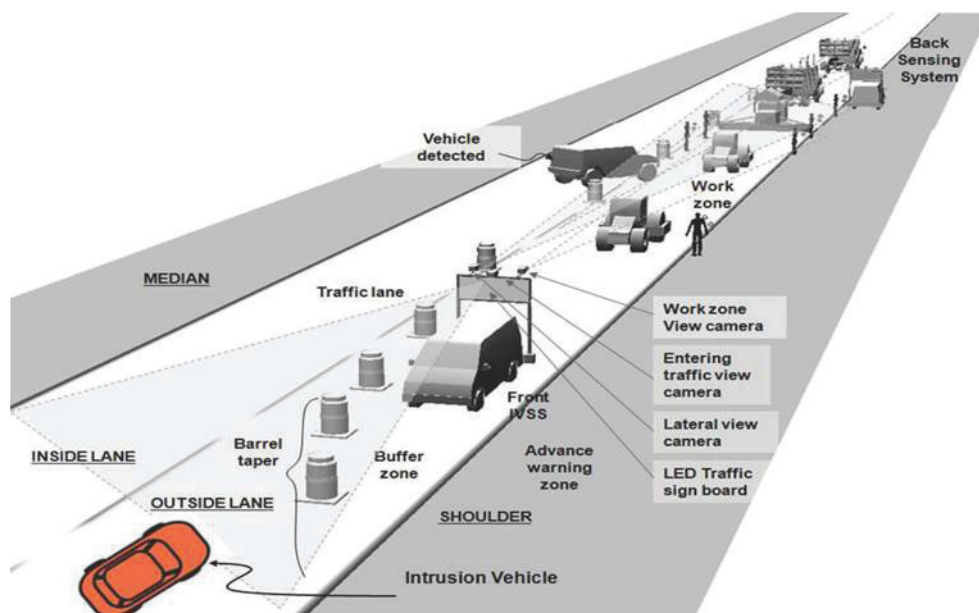

Figure 1

Intelligent vision and sensing system to detect hazard conditions in the work zone.

COMPUTER VISION TRAFFIC SENSOR FOR FIXED AND PAN-TILT-ZOOM CAMERAS

NCHRP-IDEA Project 140

Stan Birchfield [Tel.: (864) 656-5912, Fax: (864) 656-5910, Email: stb@clemsun.edu]

Wayne Sarasua [Tel.: (864) 656-3318, Fax: (864) 656-2670, Email: sarasua@clemsun.edu]
Clemson University, Clemson, South Carolina

This project developed and tested a next generation vision-based traffic sensor to collect traffic parameters such as volume, classification, and speed using both fixed and pan-tilt-zoom (PTZ) cameras. Figure 1 shows the system's versatility in a variety of camera configurations, road characteristics, lighting conditions, and weather conditions. The developed sensor is quick and easy to calibrate using just six clicks in the image. The sensor also has the ability to dynamically recalibrate itself when the camera undergoes PTZ changes. Two prototype sensors were tested at two locations (Maryland and New York) for more than 15 months. The sensor's accuracy in terms of vehicle count was comparable under various traffic, weather, and lighting conditions and often slightly better than that of the loop detectors present at the corresponding sites. The improvement was particularly noticeable in congested traffic conditions encountered at the New York test site. The project also helped make significant progress toward developing a Traffic Management Center solution using existing pan-tilt-zoom cameras. The architecture of the software was redesigned to enable the processing of multiple (up to 32) videostreams simultaneously on a single server. An automatic calibration algorithm to handle user pan and tilt was developed to further augment the system. A patent for the developed sensor technology has been filed, and the IDEA product has been commercialized with involvement of a local software company. (NTIS Report # PB2011-100031)

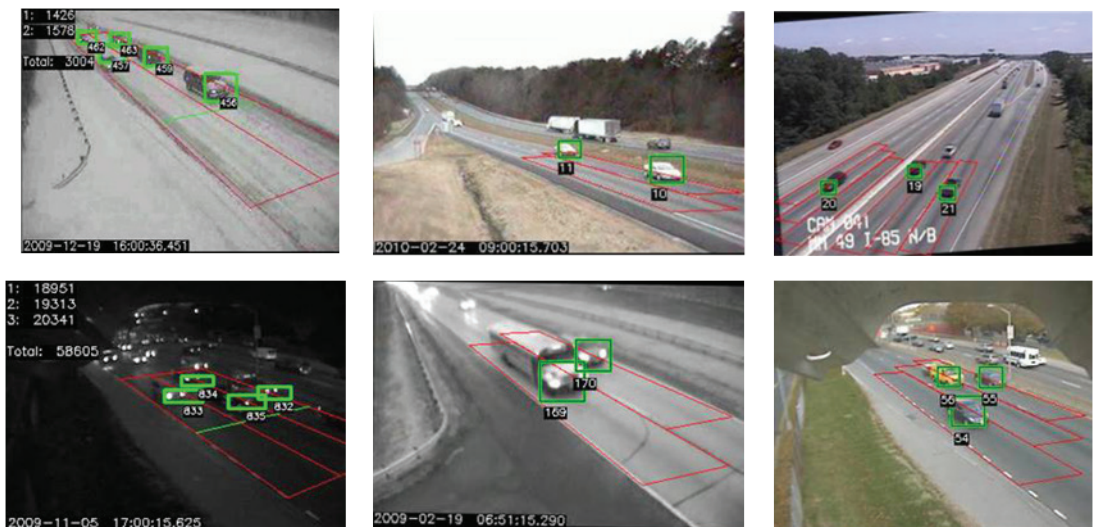

Figure 1

Detection and tracking of vehicles in a variety of scenarios, demonstrating the versatility of the system.

REDUCING FATIGUE IN WIND-EXCITED TRAFFIC SIGNAL SUPPORT STRUCTURES USING SMART DAMPING TECHNOLOGIES

NCHRP-IDEA Project 141

Richard Christenson [Tel.: (860) 486-2270, Fax: (860) 486-2298,
Email: rehriste@enr.uconn.edu] University of Connecticut, Storrs, Connecticut

This project developed a vibration absorbing system to reduce fatigue in traffic signal support structures exposed to excessive wind-induced vibration. A prototype smart vibration absorber was designed for installation onto a full-scale traffic signal support structure in the laboratory (Figure 1) and free and forced vibration tests were conducted. Three different damper types were tested including a magneto-rheological (MR) fluid damper, an air damper, and a permanent magnet damper. The final prototype design used the permanent magnet damper because of the linear viscous damping achieved and simplified mechanics of the device. The prototype was evaluated by measuring damping level in the structure from free vibration response and measured steady state accelerations from forced vibration tests. Damping in the traffic signal support structure increased from 0.1% to 10.1%, reducing free vibration time for the response to attenuate from over 5 minutes to just under 5 seconds. The system is expected to significantly reduce the wind-induced vibrations of traffic signal support structures, thereby reducing fatigue and increasing the safe life of the structure. For signal support owners, this means that fewer resources will need to be committed to replacing and repairing fatigued signal support structures. The retrofit would be applied to only those signal structures that exhibit vibration problems in the field, thus making the application and use of resources more efficient. The vibration absorber is relatively cheap, easy to install, and would provide savings in the form of increased life of the structure and supplemental information for signal support inspection. The monitoring capabilities would supplement visual inspections. Connecticut DOT's Technology Transfer Center will help in implementing the IDEA technology. (NTIS # PB2011-113455)

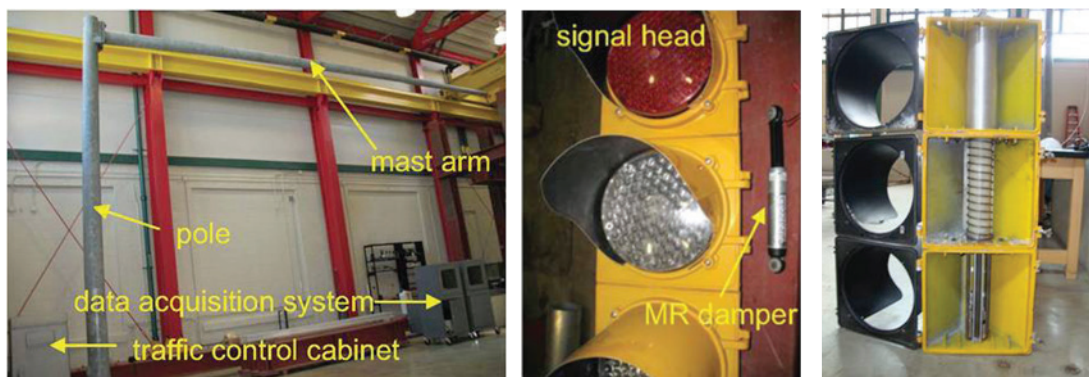

Figure 1

Traffic signal mast arm and pole in structures laboratory and signal head vibration absorber.

A SHAPE MEMORY POLYMER-BASED SELF-HEALING SEALANT FOR EXPANSION JOINTS

NCHRP-IDEA Project 142

Guoqiang Li [Tel.: (225) 578-5302, Fax: (225) 578-5924, Email: guoli@me.lsu.edu]
Louisiana State University, Baton Rouge, Louisiana

This project developed a shape memory polymer-based sealant for expansion joints in pavements and bridges that can help prevent adhesive and cohesive failures through a self-healing mechanism, thereby minimizing the need for replacing sealant. The proposed sealant was fabricated by dispersing glass microballoons into a thermosetting shape memory polymer. Through a programming or educating process, the foam sealant can be tailored to self-seal both adhesive and cohesive damage by a confined shape recovery process. Laboratory testing showed that shape memory polymer, after 2-D programming, can prevent the accumulation of excessive compressive stress in compression-sealed sealant and prevent sealant from being squeezed from a channel when concrete walls expand during the summer. Figure 1 shows the shape recovery process of the sealant after the 2-D programming. The tests also showed that the sealant had sufficient strength and stiffness under simulated traffic loading, thermal stress, and cyclic loading. The sealant was found to be functionally stable (i.e., maintaining its shape memory functionality when subjected to various combinations of environmental attacks) and showed negative Poisson's ratio at normal working temperature, which facilitates integrity of the sealant. The research also showed that the one-step 2-D programming can be replaced by a two-step 1-D programming and that thermosetting shape memory polymer can be cold-compression programmed. These findings lay a foundation for implementation of the smart sealant in practice. Shape memory polymer-based sealant was fabricated, programmed, and installed in two joints on a concrete pavement. Monitoring of the sealant's performance has continued beyond the IDEA project by the Louisiana Department of Transportation and Development. Extensive field testing is needed before the technology can be implemented in the field in actual highway environment. The final report is available from the National Technical Information Service (NTIS # PB2013-100223).

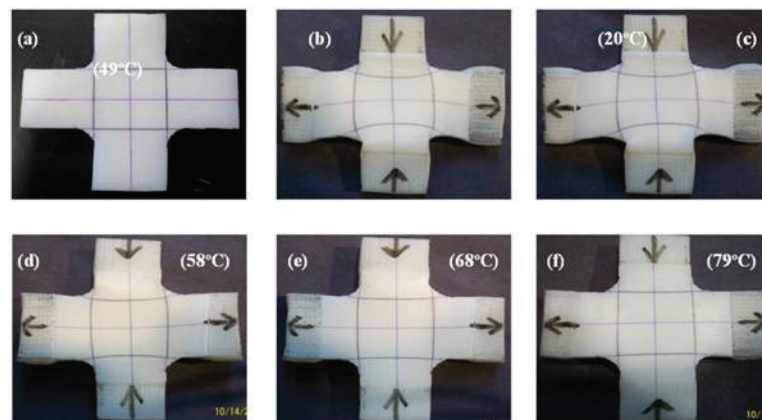

Figure 1

(a) Original and (b) programmed cruciform foam sealant specimen; and (c-f) its recovery process under various temperatures.

THE GUAYULE PLANT: A RENEWABLE, DOMESTIC SOURCE OF BINDER MATERIALS FOR FLEXIBLE PAVEMENT MIXTURES

NCHRP-IDEA Project 143

David N. Richardson [Tel.: (573) 341-4487, Fax: (573) 341-4729, Email: richardd@mst.edu]

Mike Lusher [Tel.: (573) 341-4457, Fax: (573) 341-4729, Email: smlush@mst.edu]

Missouri University of Science and Technology, Rolla, Missouri

This project explored the feasibility of using materials derived from the guayule (pronounced 'why-YOO-lee') plant in flexible pavement mixtures (FPMs). From several guayule-based materials, the most viable recycling (softening) agent in high-reclaimed asphalt pavement (RAP)/reclaimed asphalt shingles (RAS) content FPMs was an acetone-extractable resin that is present as a residue in the commercially produced, bulk guayule rubber. Binder-blends were evaluated for temperature-dependent stiffness parameters with different proportions of reclaimed RAP and RAS, and a virgin binder—either a petroleum-based recycling agent (CyclogenL or CycL) or the guayule rubber resin (RR). Tests showed that the RR-RAP/RAS blends performed similarly to the CycL-RAP/RAS blends in terms of high-temperature stiffness although slightly less effective in cold-temperature cracking resistance. The blend met all PG64-22 specifications, except mass change. For final testing, a high-reclaimed-binder-content FPM was designed according to Missouri DOT specifications. This FPM utilized only 5.5% (by weight) virgin petroleum-based binder and contained either the RR or the CycL. The results of Hamburg wheel-track testing on these two FPMs showed that the RR-based FPM performed as well as the CycL-based FPM in terms of rutting and stripping or moisture-susceptibility resistance. The results show that the RR can be used as a recycling agent in FPMs with high contents of RAP and/or RAS. The final report is available from the National Technical Information Service (NTIS # PB2013-104859).

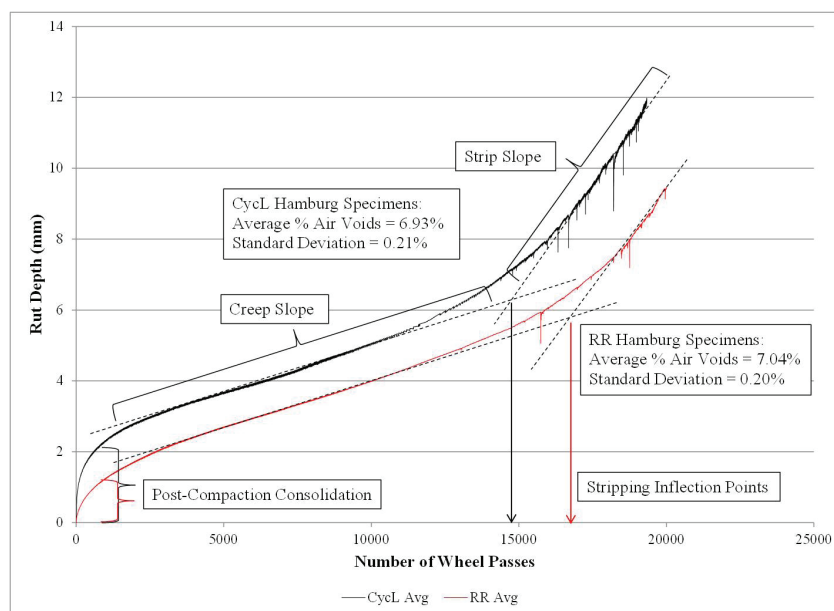

Figure 1

Hamburg Test: Rubber resin (RR) vs. Cyclogen L (CycL) flexible pavement mixture.

AN ACOUSTIC EMISSION-BASED TEST TO DETERMINE ASPHALT BINDER AND MIXTURE EMBRITTLEMENT TEMPERATURE

NCHRP-IDEA Project 144

William G. Buttlar [Tel.: (217) 333-5966, Fax: (217) 333-1924, Email: buttlar@illinois.edu]

Henrique M. Reis [Tel.: (217) 333-1228, Fax: (217) 244-5705, Email: h-reis@illinois.edu]

Behzad Behnia [Tel: (217) 721-4842, Email: bbehnia2@illinois.edu] University of Illinois, Urbana-Champaign, Illinois

This project developed an acoustic emission-based test method for characterizing the embrittlement temperature of asphalt binders and mixtures. An acoustic emission-based measurement system complete with signal processing and data analysis algorithms, along with a compact and low maintenance thermoelectric-based cooling device, was developed. Test results on asphalt concrete mixtures were very promising; microcracking of the asphalt mastic was easily detectable with the new method and highly correlated to binder test results. Figure 1 schematically shows the asphalt binder sample bonded to the granite substrate during the test. Testing of samples from the MnRoad Program also showed a good correlation between acoustic emission-based mixture embrittlement temperature and low temperature binder grade mixture fracture energy obtained from the Disk-shaped Compact Tension test, and field performance. The developed acoustic emission system was also successfully used to detect the presence and the effect of recycled asphalt pavement in asphalt mixtures. Further validation of the new testing system with field specimens was completed, including specimens obtained from the Asphalt Institute (airfield pavement durability study) and Michigan Technological University. Strong correlations between the results of acoustic emission tests and industry standard low temperature binder tests were obtained. The researcher is working with a local company, TE Technologies, Inc., to commercialize the IDEA product. The product is expected to yield significant payoff for both up-stream and down-stream suppliers and producers for material formulation, material compatibility assessment, mix design, assessment of warm-mix designs, quality assurance of binders and mixtures, optimization of mixtures using recycled asphalt pavement and assessment of pavement condition and scheduling of preventive maintenance and rehabilitation treatments. (NTIS Report # PB2012-104699)

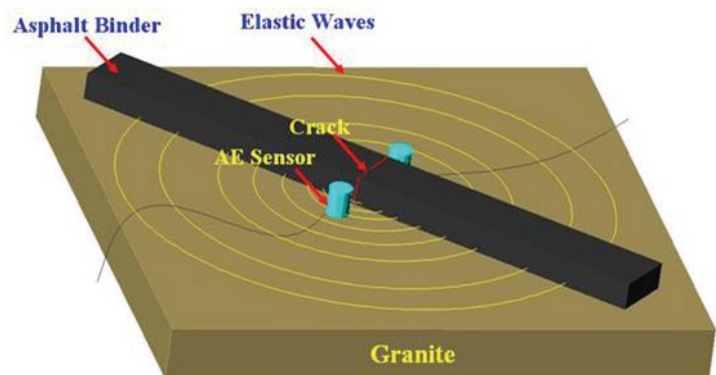

Figure 1

Schematic representation of AE asphalt binder sample during the test.

EXTRACTION OF LAYER PROPERTIES FROM INTELLIGENT COMPACTION DATA

NCHRP-IDEA Project 145

Mike Mooney [Tel.: (303) 384-2498, Fax: (303) 273-3602, Email: mooney@mines.edu]
Colorado School of Mines, Golden, Colorado

This project developed a methodology to extract layer elastic modulus/stiffness from composite soil stiffness and GPS-based position provided by currently available vibratory intelligent compaction (IC) rollers. The developed methodology combines two key components that were advanced in this investigation, namely, forward modeling and inverse analysis. Forward modeling efforts focused on finite element and boundary element method techniques to predict roller-measured composite stiffness values for ranges of layer elastic moduli and layer thickness expected in practice. Inverse analysis or back-calculation works in reverse and provides an estimate of individual layer elastic modulus using IC data. The investigation demonstrated that layered elastic modulus can be estimated from IC data over a wide range of layered earthwork configurations (layer thickness and ratio of layer moduli). The methodology can be implemented via software algorithms that can be integrated into any commercially available IC software offered by roller manufacturers, consultants, and third-party vendors (e.g., navigation system providers). The implementation of this latter approach could be performed by any interested party. The generated methodology is generic and can be applied to any currently available proprietary measures of ground stiffness from vibratory rollers. The final report is available from the National Technical Information Service (NTIS # PB2013-108441).

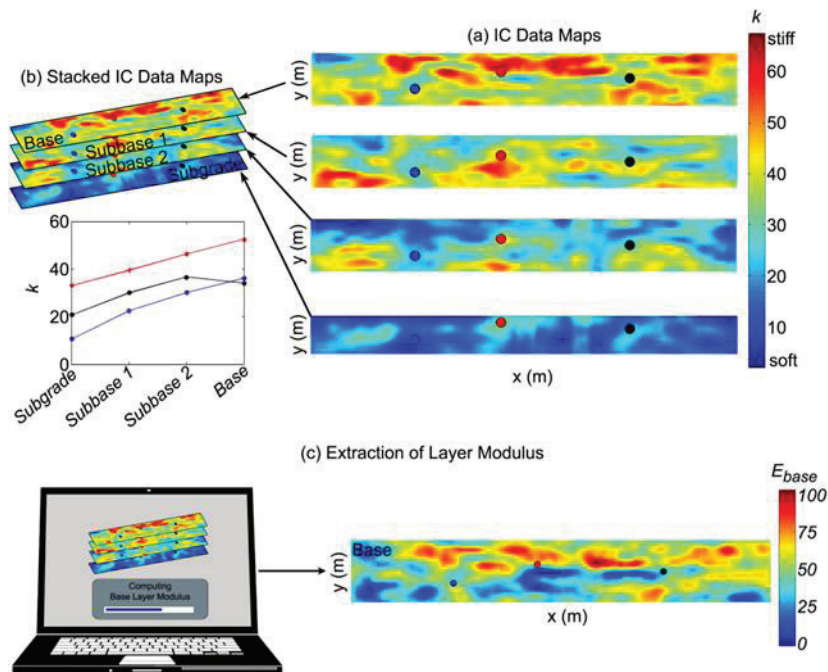

Figure 1

Conceptual illustration of the proposed process: extracting layer moduli from composite stiffness measured during construction of a pavement support structure.

ADVANCED METHODS FOR MOBILE RETROREFLECTIVITY MEASUREMENT ON PAVEMENT MARKING

NCHRP-IDEA Project 146

Terry Lee [Tel.: (603) 369-2785, Fax: (303) 600-4121, Email: leetronvision@gmail.com]
Leetron Vision, Concord, New Hampshire

This project developed a prototype mobile unit for a rapid and reliable measurement of pavement marking retroreflectivity. The unit consisted of a retroreflectivity measurement system, tracking system, geometry measurement system, neural network system, and speed simulator system. The unit's repeatability of the measurement on a sample strip at simulated highway speeds was satisfactory, and tests showed close correlation between hand-held and mobile units under stationary conditions (Figure 1). Road tests indicated that the results are repeatable (Figure 2). After additional refinements were implemented on the tracking system, road test results achieved a repeatability error under 1.5%. Because of the success of the prototype, more engineering and financial resources are being applied toward commercializing the system. A beta production version of the system has been designed and built. Currently, the system is in the testing and refinement phase. The final report is available from the National Technical Information Service (NTIS # PB2012-110782).

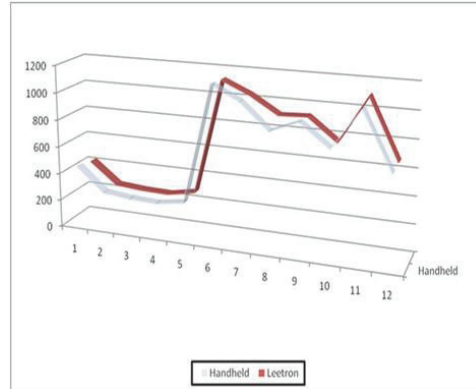

Figure 1

Measurement comparison between handheld unit and Leetron unit on 12 sample marking strips.

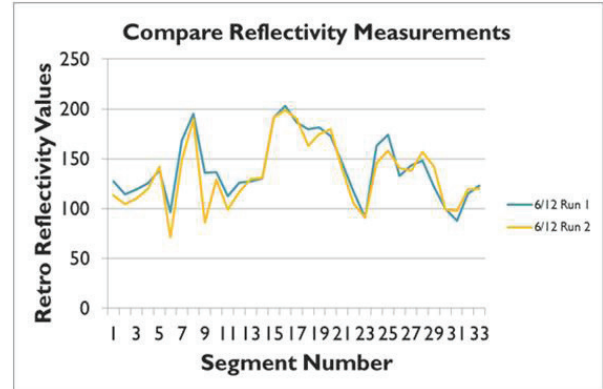

Figure 2

Repeatability road test at 60 mph.

SHAPE MEMORY ALLOY ENHANCED SMART BRIDGE EXPANSION JOINTS

NCHRP-IDEA Project 147

Jamie E. Padgett [Tel.: (713) 348-2325, Email: jp7@rice.edu] Rice University, Houston, Texas

Reginald DesRoches, Georgia Institute of Technology, Atlanta, Georgia

This project provides a new type of bridge expansion joint, referred to as a SMART joint using shape memory alloys (SMAs), that can accommodate not only service loads but also larger displacement demands required during extreme events like earthquakes. The system offers an intermediate alternative between commonly installed service level expansion joints and dedicated seismic expansion joints that generally add to costs and complexity. The SMART expansion joint integrates nickel titanium SMAs to modify a commonly installed modular bridge expansion joint. Through strategic placement within the bridge joint, advantageous and unique SMA behaviors are introduced into the expansion system, such as recentering and energy dissipating characteristics (improving seismic behavior) and corrosion resistance (alleviating joint maintenance costs). A full-scale SMART expansion joint prototype was developed and tested (Figure 1). Through limited alteration of the existing joint configuration, up-front costs are minimized (less than 15% increase over a basic service level joint).

The validity and benefits of this new expansion joint system were evaluated through a systematic research program including component and full-scale joint experimental testing, analytical modeling of the joint, reliability assessment of the joint within a bridge system, and subsequent life-cycle cost-benefit analyses. The SMART joint design preserves existing desirable service load behavior of the joint, but can accommodate significant increases in longitudinal displacement capacity under dynamic loads, while limiting internal load transfer that would otherwise lead to failure of joint components. These improvements translate into reduced joint repair and replacement costs and improved post-event functionality of bridges, offering systems that are capable of accommodating traffic passage after a hazard event. Furthermore, advanced performance and functionality were afforded without changing the field construction requirements in order to provide easy transfer of the technology. The minimal increase in cost makes the SMART joint a cost-effective solution even in regions of moderate seismicity, given the significant reduction in joint failure probability across a range of hazard levels. The coupled reduction of expected life-cycle costs and preservation of current field construction requirements eases future transfer of the smart joint technology into practice. (NTIS Repot # PB2014-100623)

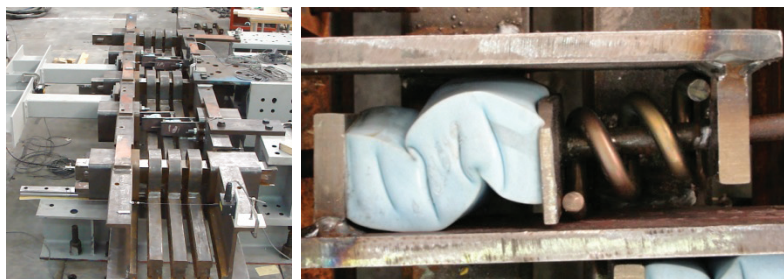

Figure 1

SMART expansion joint and close up of expansion system incorporating SMA spring.

CLEANING DEVICE TO REMOVE DEBRIS AND CHEMICALS FOR CRACK/JOINT SEALING

NCHRP-IDEA Project 148

Yong Cho [Tel.: (402) 554-3277, Fax: (402) 554-3850, Email: ycho2@unl.edu]

University of Nebraska, Lincoln, Nebraska

Debris and foreign materials left in a crack (resulting from sawing, routing, or pavement use) contaminate the sealing or filling material and reduce cohesion. Deicing chemicals left in cracks during winter present an especially critical problem related to early failure of sealed cracks. To avoid these contamination-related failures, cracks must be cleaned prior to being treated. This project developed a low-cost and effective mechanical tool to prepare random cracks and joints for sealing (Figure 1). The system incorporates two traditional crack cleaning methods (wire brushing and air blasting) into one device. The device uses a pneumatically driven rotary wire brush to clean cracks of mid- to large-sized debris and vegetation. Directly behind the rotary brush, variable direction air blasting nozzles are used to further expel fine grained particulate like concrete dust, fine sand, and—most importantly—winter deicing chemicals from the walls and surfaces of the pavement cracks. The prototype was evaluated in the laboratory for mechanical durability, brush effectiveness, air blast effectiveness, ergonomics, and equipment adaptability. Following necessary improvements, the prototype was further tested in the field at two highway crack sealing sites in collaboration with the Nebraska Department of Roads. The device was also successfully demonstrated to the City of Omaha street maintenance group in Nebraska. A pavement repair equipment company, Crafcro, Inc., has expressed interest in further development of the device and in its commercialization. (NTIS Report # PB2011-114172)

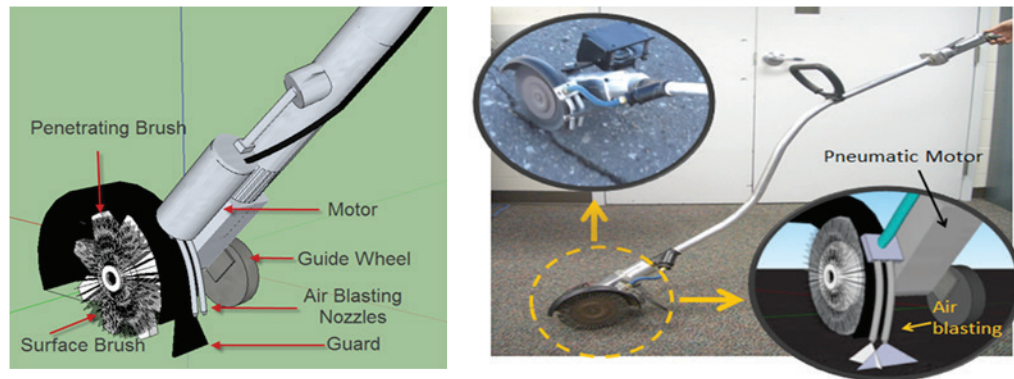

Figure 1

Crack cleaning device concept and product.

USE OF ENERGY-ABSORBING BREAKAWAY POSTS FOR W-BEAM GUARDRAILS IN FROZEN SOIL CONDITIONS

NCHRP-IDEA Project 149

King Mak [Tel./Fax: (210) 698-0556, Email: kingkmak@sbcglobal.net]

John Rohde [Tel.: (402) 554-3049, Fax: (402) 554-3288, Email: jrohde@unl.edu]

Safety by Design Co., Lincoln, Nebraska

The goal of this project was to develop, test, and demonstrate the application of breakaway posts with energy absorbing capability to enhance the safety performance of W-beam guardrails in frozen soil conditions. From the four initial concepts, two designs were selected for further evaluation based on potential impact performance, manufacturability, and cost. The bent-plate design (Figure 1) showed the desired failure mechanism, although the force level was lower than that required for proper impact performance. The bogie test was then simulated using the LS-DYNA computer simulation program. Based on the calibrated simulation model, the thickness of the bent plate was optimized to increase the force level while maintaining the manufacturability. Additional bogie tests were conducted on the optimized design, and the results showed acceptable force levels. Computer simulation of a guardrail system with breakaway posts was then conducted with satisfactory results indicating that implementation of this new guardrail post could potentially reduce the severity of guardrail crashes and the associated serious and fatal injuries. The next step was to conduct a full-scale crash test at the Midwest Roadside Safety Facility. The post manufacturer, Road Systems, Inc., had agreed on the finalized design and to contribute to the cost for the full-scale crash test. However, after reevaluating the potential market for the new posts, Road Systems, Inc. determined them to be not viable in the current market and withdrew support from the full-scale crash test. Implementation of the new posts requires fabrication and full-scale crash testing followed by field tests in collaboration with state Departments of Transportation. (Final Report NTIS # PB2016-100667)

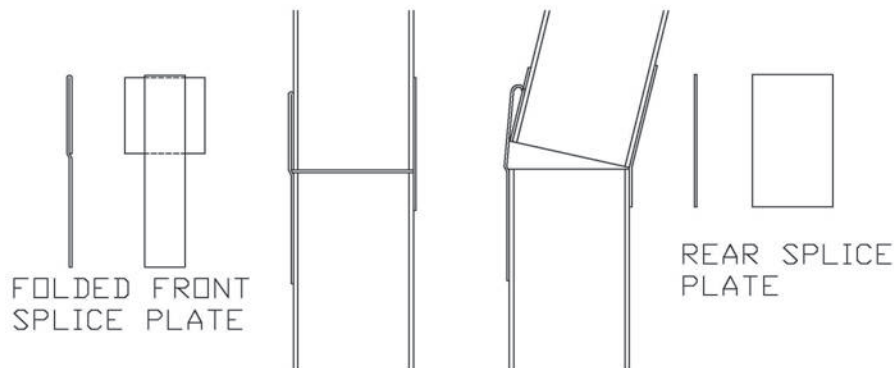

Figure 1

Schematic of bent plate design.

AUTOMATED LASER SPECTROGRAPHIC PATTERN MATCHING FOR AGGREGATE IDENTIFICATION

NCHRP-IDEA Project 150

Warren Chesner [Tel.: (516) 431-4031, Fax: (516) 717-2621, Email: wchesner@chesnerengineering.com] Chesner Engineering, P.C., Long Beach, New York

This project evaluated the feasibility of using laser-induced breakdown spectroscopy (LIBS) technology as a quality-control tool to conduct real-time scans of aggregates that are used in highway construction applications. LIBS is a rapid method laser-scanning technique in which a very quick pulse of energy from a high-powered laser is optically focused to a point, instantaneously heating the target sample to vaporize and atomize nanograms of material within a microplasma with a corresponding release of light. To identify the specific target material, the intensity of the wavelengths of light released in this process is spectrally and temporally resolved.

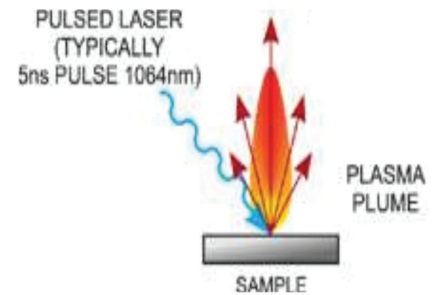

In this project, aggregates were targeted with a high-powered laser, and multivariate statistical modeling techniques were used to determine whether aggregates of interest exhibit definable spectral patterns that could be correlated with selected engineering properties of the target samples. In tests, mineral aggregates were found to exhibit unique spectral fingerprints or spectral patterns when subjected to a high irradiance, which was induced by focusing a high-powered laser onto very tiny spot on a target aggregate material. These spectral patterns were successfully correlated with engineering material properties of the targeted material. The acid insoluble residue content, the presence of D-cracking susceptibility, and alkali-silica reactivity were accurately predicted using multivariate determinant models on aggregates supplied by the New York, Kansas, and Texas departments of transportation (DOTs), respectively. A prototype system for field use in an actual quarry is being developed in NCHRP-IDEA Project 168, and a pooled-fund study involving several state DOTs with Kansas as the lead state will further evaluate the technology for implementation. (NTIS Report # PB2012-111107)

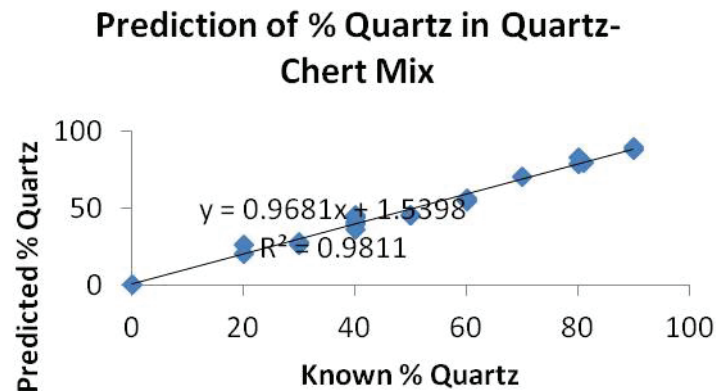

Figure 1

Calibration for percent quartz in quartz-chert mixtures of samples from Texas DOT.

DEVELOPMENT OF A SIMPLE TEST TO DETERMINE THE LOW-TEMPERATURE STRENGTH OF ASPHALT MIXTURES AND BINDERS

NCHRP-IDEA Project 151

Mihai Marasteanu [Tel.: (612) 625-5558, Fax: (612) 626-7750, Email: maras002@umn.edu]
University of Minnesota, Minneapolis, Minnesota

In NCHRP-IDEA Project 133, a simple bending creep test on thin beams of asphalt mixtures was developed. However, mixture creep compliance only represents one of the two parameters required to predict low-temperature performance; strength is the other critical parameter needed in the American Association of State Highway and Transportation Officials pavement design guide low temperature algorithm. This follow-on project developed a strength test for asphalt mixtures using the same bending beam rheometer (BBR) device from Project 133. The product is a BBR that can run low-temperature creep and strength tests for both asphalt binder and mixture specimens.

Using a modified BBR with a new proportional valve system and a heavier loading frame, beam replicates for asphalt binders and mixtures were tested. There was a significant difference between BBR and direct tension test (DTT) asphalt binder strength results. It was found that ethanol significantly reduced the strength values, most likely due to environmental stress cracking. Further investigation concluded that testing in air represented the best option for mixture testing, for which the results are less sensitive to small temperature fluctuations. Given the smaller dimension of the BBR beam compared to the RVE size of asphalt mixture, a mathematical model for reconstructing the material RVE was proposed. The RVE model was validated through histogram testing on larger specimens. The good agreement between the predicted strength obtained from the RVE model and the experimental results indicated that BBR could provide a simple alternative to asphalt mixture strength testing (Figure 1). This research, thus, may provide the asphalt industry with a simple test method to determine asphalt materials properties that are critical in material specification and selection processes. The reduced specimen thickness makes this method an ideal candidate for investigating aging effects in real pavements. The smaller size of test specimen also allows for investigating the properties of thin and ultra thin layers made with premium materials, a technology that has seen considerable growth in recent years. (NTIS Report # PB2013-108442)

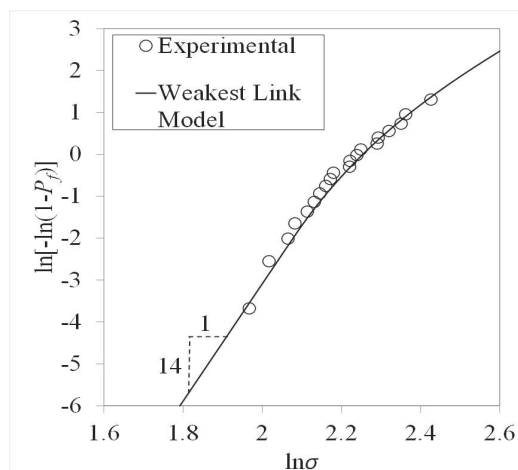

Figure 1

Bending beam rheometer (BBR) strength histograms and weakest link model prediction for asphalt mixture.

BRIDGE CABLE INSPECTION WITH LONG-RANGE ULTRASOUND

NCHRP-IDEA Project 152

Thomas R. Hay [Tel.: (814) 237-1031, Fax: (814) 237-1031,

Email: thomhay@wavesinsolids.com] WavesinSolids LLC, State College, Pennsylvania

This project developed and demonstrated the application of a rapid and reliable non-destructive method, based on long-range ultrasound, of inspecting bridge cables for corrosion, wire breaks, and other structural flaws (Figure 1). Cable inspection tests, performed in controlled laboratory environment by inserting artificial flaws at a suspender rope-cable socket interface showed the long-range ultrasound was sensitive to those small flaws and that the change in data relative to baseline data on a structurally sound cable could be used to track damage at this interface. Cable inspection was also performed in the field on the suspender ropes on the Manhattan Bridge. Changes in cross-sectional area (CSA) of all five ropes tested were identified using guided wave ultrasound. Visual inspection of these ropes confirmed these findings. The project also explored the feasibility of inspecting the main cable of a cable-stay bridge. From a single sensor position, the technology scanned approximately 120 feet of cable. The results showed, for the first time, that main cables could be inspected with the proposed technology and that the technology is sensitive enough find changes in CSA as small as 3%, as it showed a strong correlation between changes in select waveform features and increases in CSA loss. Based on an initial estimate, the cost for retrofitting a bridge and periodic inspection appear to be \$34,000 and \$8,000, respectively, for a 200 cable bridge. The final report is available from the National Technical Information Service (NTIS # PB2012-110783).

Handheld instrument is used to download data from bridge



Data is uploaded to database for damage tracking



Cable ID	Damage Level
West Side 1	3% CSA at socket
West Side 2	None
West Side 3	25% CSA at socket
West Side 4	None

Figure 1

Suspender rope correlation coefficient with increasing percent cross-sectional area (CSA) loss.

BRIDGE RETROFIT LASER SYSTEM

NCHRP-IDEA Project 153

Paul Fuchs [Tel.: (703) 737-3871, Fax: (703) 737-6381,

Email: paul.fuchs@fuchsconsultinginc.com] Fuchs Consulting, Inc., Leesburg, Virginia

This project developed laser metrology instrumentation to aid in the bridge retrofit process. The complete system can make measurements that are difficult or impossible to make with manual string-line or tape measurements. It can measure with minimal impact at the bridge site, including measurements over water or other difficult access conditions, such as rail lines. A noncontact laser system measures the sections of a bridge structure that are involved in a retrofit process. These laser measurements produce CAD design drawings of retrofit parts. The laser system can measure the shape, position, and dimension of members on the bridge. The complete system is driven to a bridge site in a vehicle, quickly setup, and used to make measurements. No special targets are needed on the bridge, and the system can make highly accurate measurements over very large distances directly on the bridge members, including the exact dimensions and spatial location of bridge details. It has the potential to replace currently used manual measurements that use string lines and conventional survey equipment. Work was performed with retrofit fabricators and state departments of transportation to determine measurement requirements and application areas. A number of field measurements were made that included measurements on a bridge struck by an over-height load (Figure 1). Measurements were made quickly and efficiently on multiple lanes in traffic without lane closures. The system accurately measured localized damage, and it can also measure global change in an entire girder. The system has been used to evaluate steel truss bridges to measure vertical and diagonal members, and localized damage in gusset plates. The researcher is working with several key partners in the bridge retrofit process with the intent of producing a system to immediately benefit the current retrofit process. (NTIS Report # PB2013-108642)

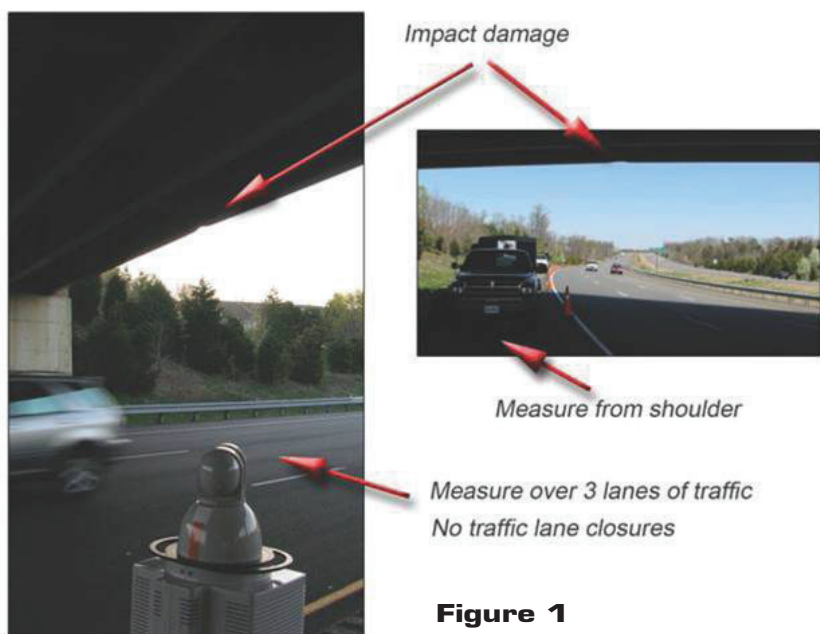

Figure 1

Measurement of impact damage on a steel girder bridge over a roadway without altering traffic.

AN INNOVATIVE HYBRID SENSOR FOR RAPID ASSESSMENT OF SULFATE INDUCED HEAVING IN STABILIZED SOILS

NCHRP-IDEA Project 154

Anand J. Puppala [Tel.: (817) 272-5821, Fax: (817) 272-2630, Email: anand@uta.edu]
The University of Texas, Arlington, Texas

The concept of this project was to develop a sensor (Figure 1) that uses both time-domain reflectometry and bender element technologies to detect the stiffness and moisture contents of soils. This sensor could be used to conduct a quick assessment of sulfate heaving problems in chemically treated sulfate soils or it could be used to conduct continuous measurements of water content, shear wave velocities, and compression wave velocities in a soil sample.

The developed sensor was embedded in lime- and cement-treated soils to monitor changes in both moisture content and shear wave velocity at various time periods. Laboratory assessments indicated that cement-treated soils experienced higher stiffness losses as compared with lime-treated soils. For field implementation and validation, a test section was chosen in the median area between Highway 114 and International Parkway near the Dallas/Fort Worth airport. Sulfate tests conducted on the natural soils indicated that the sulfate content was in excess of 30,000 ppm. A 25-ft. x 60-ft. section was built in this area and the subgrade was treated with 6% lime. The developed hybrid sensor was embedded at a depth of 8 in. in the treated section. The treated section was watered three times a day to keep continuous supply moisture for uninhibited sulfate reactions in the treated soil. Field test results indicated a reduction in shear modulus with time in the lime-treated test section. The results also reconfirm the laboratory findings that the shear modulus decreased in chemically treated sulfate rich soils owing to the deleterious reactions among soils and mineral and chemical stabilizers. Additional field testing and evaluation is needed before this technology can be implemented by highway agencies. (NTIS Report # 2014-100624)

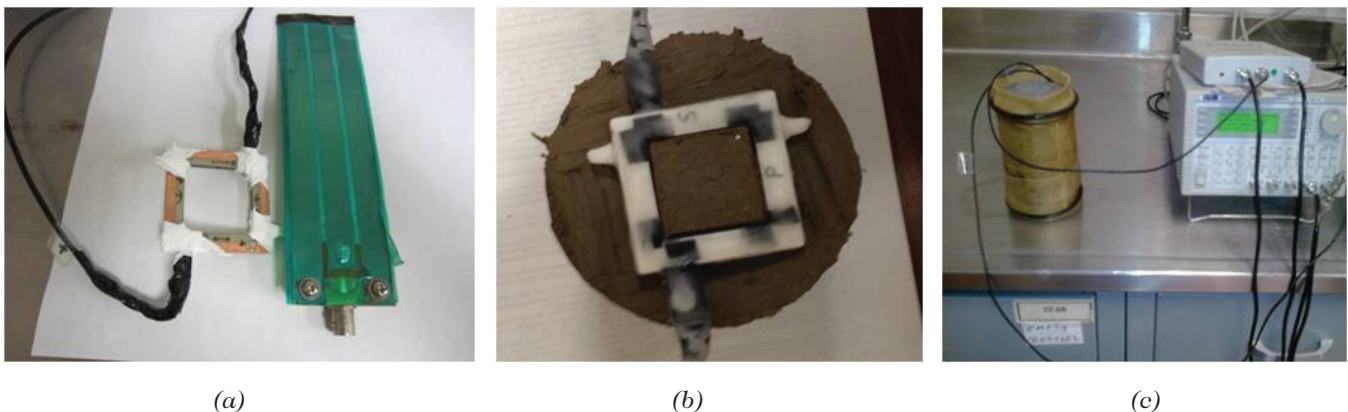

Figure 1

(a) Present bender element sensor with time-domain reflectometry strip; (b) embedment of sensor in a treated soil specimen; and (c) stiffness measurements.

CORROSION RESISTANT, STRUCTURALLY REINFORCED, THERMAL SPRAY COATINGS FOR IN-SITU REPAIR OF LOAD-BEARING STRUCTURES

NCHRP-IDEA Project 155

Sanjay Sampath [Tel.: (631) 632-9512, Fax: (631) 632-7878,

Email: Sanjay.Sampath@stonybrook.edu] Stony Brook University, Stony Brook, New York

This project was aimed at developing and demonstrating the feasibility of in-situ reclamation of corroded components in load-bearing infrastructures (such as bridges) to provide robust corrosion protection with high-velocity thermal spray coating (Figure 1). A high-velocity oxy-fuel (HVOF) thermal spray process was used to deposit iron (Fe) or nickel (Ni) as the reclaimed materials. Process optimization with in-situ monitoring of residual stresses demonstrated that compressive residual stresses could be achieved in HVOF reclamation material. Mechanical testing showed that the addition of the coating resulted in load recovery and enhancement in yield stress, suggesting good coupling between the reclaimed material and the parent metal, as well as demonstrating load-bearing capability of the HVOF coating. Thin Ni coatings presented a better performance compared to Fe coating since they were able to endure excessive loads and displacements without delamination. Still, both coatings presented an increased load-bearing capacity compared to virgins, uncoated tensile test specimens. At thick coatings, new spraying parameters were required in order to produce more compressive coatings as they were showing premature failure. The new compressive Ni coatings presented the highest load-bearing capacities, compared to all coatings and virgin tensile specimens. The composite repaired structure with Ni overlay also showed excellent corrosion resistance. These results represent a good transition opportunity to further and implement the technology on larger-scale structural components in collaboration with state departments of transportation. The final report is available from the National Technical Information Service (NTIS # PB2013-108643).

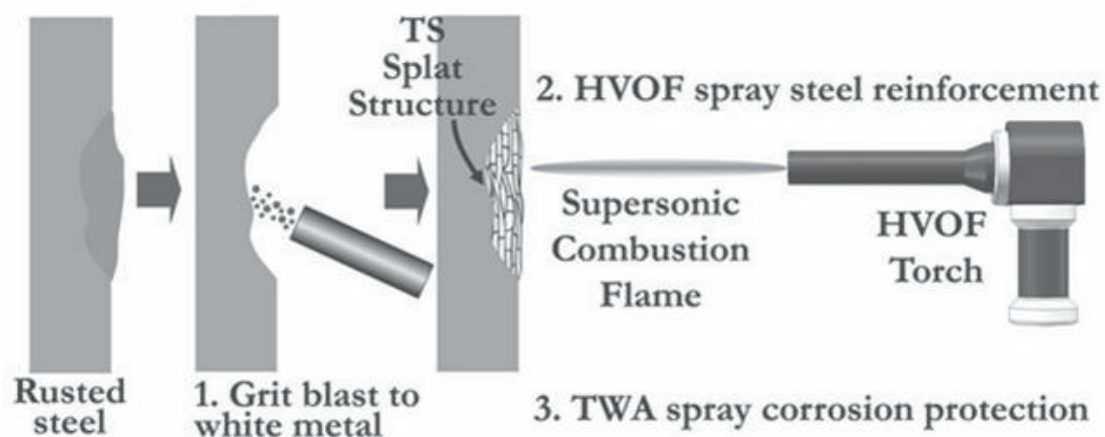

Figure 1

Schematic of the proposed thermal spray reclamation process (HVOF = high-velocity oxy-fuel; TWA = twin wire arc).

NOVEL COATING TECHNOLOGY FOR IMPROVING THE CORROSION RESISTANCE AND MECHANICAL PROPERTIES OF REINFORCING STEEL IN CONCRETE

NCHRP IDEA Project 156

Leonardo Caseres [Tel.: (210) 522-5538, Fax: (210) 522-5122,

Email: leonardo.caseres@swri.org] Southwest Research Institute, San Antonio, Texas

The goal of this project was to develop a new solution-based diamond-like carbon (s-DLC) coating with improved corrosion and mechanical performance as compared with commercially available coatings for concrete-reinforcing steel. The s-DLC synthesis process differs from traditional techniques in that it does not require high temperature or vacuum conditions. Work in the initial stage involved optimizing the coating performance prior to application to reinforcing steels. For coating optimization, scanning electron microscopy (SEM), Raman spectroscopy, and electrochemical techniques [such as electrochemical impedance spectroscopy (EIS), and linear polarization resistance] were used to characterize the coating applied to flat steel coupons. After coating optimization, several coated bars were embedded in mortar samples admixed with various amounts of chloride (from 0 to 5% wt. of mortar) and partially immersed in simulated seawater for up to 140 days. For comparison, additional reinforcing steel samples were vacuum deposited with DLC coatings such as standard DLC, multilayer Si DLC, Si-F-O DLC, and thick DLC coatings, and tested in mortar in a way similar to the s-DLC samples. SEM analysis revealed microcracks in the s-DLC films deposited on the rebar surface. To mitigate cracking, changes in pyrolysis process parameters such as the heating and cooling rates were investigated along with exploring alternative wet-coating techniques. Multiple layers of s-DLC films were also applied to the rebars in efforts to mitigate cracking. Both approaches appeared successful in mitigating cracks. The corrosion properties of the coated mortar samples were examined using the linear polarization technique.

The results showed that for 0% chloride corrosion rates were negligible/low (<0.1 mpy) for the s-DLC, Si-F-O DLC, and thick DLC coatings, but moderate (0.65–0.90 mpy) for standard DLC and multilayer Si DLC coatings. The corrosion rates increased with an increase in chloride content, which was more notable for the s-DLC coating. By the end of the 140-day exposure, the corrosion rate for 0.5% chloride was high (1.9 mpy) for the s-DLC coating, moderate (0.55 mpy) for the standard DLC and multilayer Si DLC coatings, and negligible (<0.07 mpy) for the Si-F-O DLC and thick DLC coatings, indicating that coating defects are likely to be present in the s-DLC, standard DLC, and multilayer Si DLC coatings. Similar trends were recorded for the 1% and 3% chloride contents. For the 5% chloride content, all of the DLC coatings showed high corrosion rates (>1.4 mpy) except for the thick DLC coating, which exhibited a moderate corrosion rate (0.75 mpy). The linear polarization results were in agreement with the EIS measurements. Further research is needed to improve the corrosion protection of s-DLC coating if it is to be viable for use on reinforcing steel. The Southwest Research Institute is working on this issue and, once this is resolved, will formalize teaming arrangements through negotiated business agreements to support technology integration and transition. The Institute intends to involve small businesses for scaling up synthesis from the pilot synthesis to larger production (500–2,000 gallons) of s-DLC coatings. Additional potential technical transfer teaming partners include large chemical and coatings companies. (Final Report NTIS # PB2016-100668)

DEVELOPMENT OF AN INTRINSICALLY CONDUCTING POLYMER-BASED LOW-COST, HEAVY-DUTY, AND ENVIRONMENTALLY FRIENDLY COATING SYSTEM FOR CORROSION PROTECTION OF STRUCTURAL STEELS

NCHRP-IDEA Project 157

Tongyan Pan [Tel.: (312) 567-5860, Fax: (312) 567-3519, Email: tpan@iit.edu]
Illinois Institute of Technology, Chicago, Illinois

The project was aimed at developing and demonstrating the application of a low-cost, environmentally safe, polymer-based coating system for the corrosion protection of structural steel in highway facilities. A promising π -conjugated polymer, which was also an intrinsically conducting polymer (ICP), was developed and incorporated in the primer layer of the proposed two-layer coating system. The ICP-based primer demonstrated three major anti-corrosion mechanisms: (i) ennobling substrate surface, (ii) reducing coating delamination, and (iii) smart self-healing initiated corrosion. The two-layer coating system was made by coating the primer with a robust polyurethane layer and subjected to ASTM tests B117 (Salt Spray Test), D5894 (Cyclic Salt Fog and UV Exposure Test), and D4541 (Pull-Off Strength of Coatings). Results indicated that this two-layer system possessed long-term durability, was able to provide long-term corrosion protection to steel substrate, and had strong long-term adhesion to the substrate steel surface. Two best-performing coating systems, each with an ICP-based primer layer, were then selected for field evaluation. Two field sites were selected for evaluating the performance of the selected coatings. Coated steel panels were exposed to the field corrosive conditions on a wooden stand at a 45° angle with respect to the ground surface. Figure 1 shows the field testing stacks and the SEM images of the substrate-primer-topcoat interfaces for two of the systems after 12 months of field exposure. After 12 months of field testing, the coating system including an ICP-based primer (made by mixing ICP in a regular epoxy matrix) and a polyurethane topcoat continued showing anti-corrosion performance comparable to that of the system with a zinc-rich primer and a polyurethane topcoat. (NTIS Report Number: PB2017-101834)

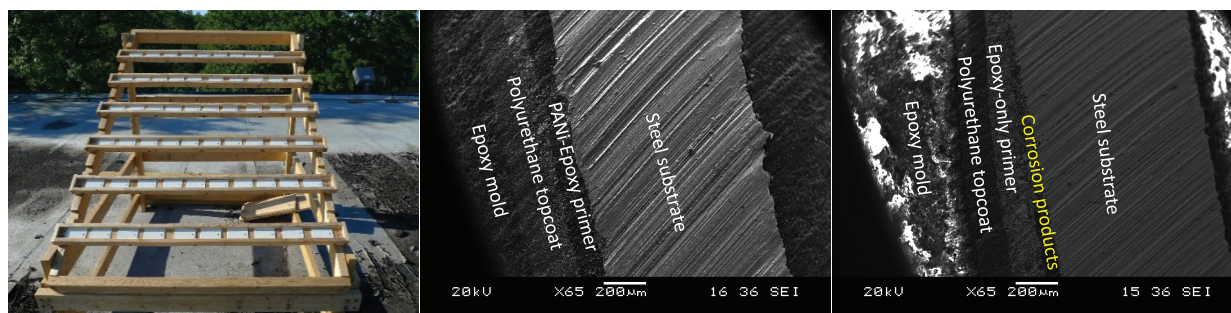

Figure 1

Field testing scheme (left) and SEM images of substrate-primer-topcoat interfaces of (middle): PANi Epoxy primer with a polyurethane topcoat, and (right): epoxy-only primer with a polyurethane topcoat.

USING NONLINEAR ACOUSTICS TO IDENTIFY THE STRESS STATE OF CRITICAL BRIDGE COMPONENTS

NCHRP-IDEA Project 158

Didem Ozevin [Tel.: (312) 413-3051, Fax: (312) 996-2426, Email: dozevin@uic.edu]
University of Illinois at Chicago, Chicago, Illinois

This project was aimed at developing and demonstrating the application of a nonlinear acoustics-based technique (Figure 1) for identifying the stress state of critical highway bridge components through laboratory-scale and field testing. Currently, there is no rapid, cost-effective method for measuring actual loading on structural elements as a result of the dead load of existing structures. Increasing transportation demand as well as fatigue and corrosion may lead to critical bridge components reaching an overstressed state. The proposed approach can serve as a rapid inspection method for bridge inspectors to obtain the stress level of critical bridge components. Theoretical and numerical models were developed to identify the most sensitive ultrasonic waves to the level of stress on structural steel. The selected ultrasonic waves were tested on an L profile loaded uniaxially and a gusset plate loaded uniaxially and bi-axially. The method was tested on two bridges located in Illinois (a fracture critical bridge spanning the Calumet River allowing access to Halsted Street) and Virginia (Norris Bridge). Work has continued with support from the National Science Foundation. Communications have been initiated with a manufacturer of hand-held ultrasonic testing devices. Once the algorithm is finalized, it can be easily embedded into the integrated circuit FPGA (field-programmable gate array) for automated stress measurement. The approach has been successfully demonstrated on two actual highways, which is a critical step in proving the readiness of this technology. (Final Report NTIS # PB2016-100669)

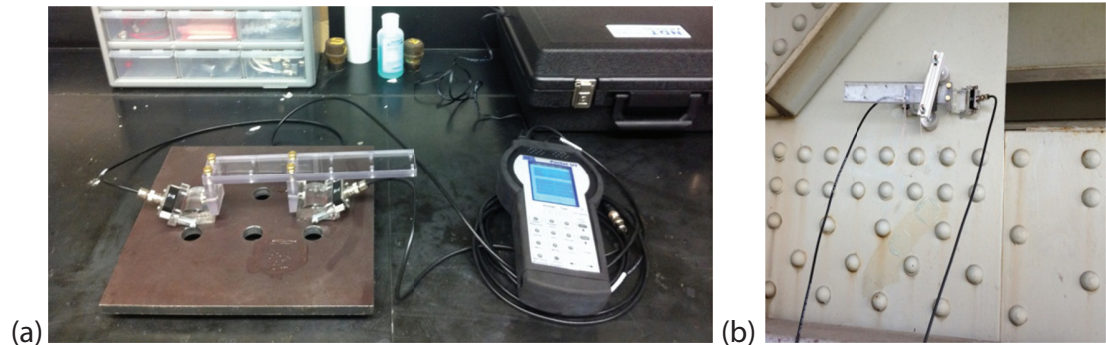

Figure 1

Fixture designed for ultrasonic wave transmitter and receiver with variable angle and distance: (a) on a laboratory sample and (b) on a gusset plate at a fracture critical bridge in Illinois.

ADVANCED CLEANING DEVICE TO REMOVE DEBRIS AND CHEMICALS FOR CRACK/JOINT SEALING

NCHRP-IDEA Project 159

Yong Cho [Tel.: (402) 554-3277, Fax: (402) 554-3850, Email: yong.cho@ce.gatech.edu]
Georgia Institute of Technology, Atlanta, Georgia

The aims of this project were to improve and retrofit the design of a pavement crack cleaning device (CCD), developed in the previous IDEA project (NCHRP-148), to make it more practical and functional by adding functions such as routing, hot air blasting, and vacuuming (Figure 1). As an outcome of the previous research, a conceptual prototype of a CCD was designed, utilizing pneumatic power for air blasting and abrasive wire brushing to simultaneously remove debris or de-icing chemicals that were used in cold winter and remained in cracks. In the current project, a router, an electric heat lance, and a vacuum system have been incorporated as possible options for the CCD. An electrical heat lance was designed to properly warm the pavement and expel moisture to promote bond adhesion. In addition, a vacuum system was developed as a means of collecting debris and dust to remove road hazards and improve operator safety while conforming to OSHA and EPA guidelines. Routing and saw cutting functions were also added to the CCD. For field validation of the CCD and to gain industry acceptance of the technology, several industry demonstrations and field tests were conducted. CCD units were provided to the Nebraska Department of Roads (NDOR) for use during the full sealing season in 2012–2013. Also, demonstrations were conducted at the Crafcro, Inc. manufacturing facility in Chandler, Arizona, and at the City of Omaha, Nebraska, road maintenance division. Productivity data along with the crews' feedback were collected during the field tests. The analyzed results showed the CCD design concepts to be well received by all participating industries for the CCD's positive impact highway on road maintenance and for improving productivity, safety, and maintenance cost. Crafcro, Inc. has shown strong interest in the commercialization of the CCD. Successful commercialization and industry adoption of the CCD for crack and joint preparation would lead to an increase in overall quality of pavement maintenance, an increase in the useful life of pavements, and a reduction in the costs of rehabilitation or new construction of roadways. (NTIS Report # PB2014-100625)



Figure 1

The latest versions of heat lance (left) and vacuum attachments (right).

SUPER-WEATHERING STEEL FOR INFRASTRUCTURE APPLICATIONS

NCHRP-IDEA Project 160

Semyon Vaynman [Tel.: (847) 491-4475, Fax: (847) 491-7820,

Email: saynman@northwestern.edu] Northwestern University, Evanston, Illinois

This project developed and tested the mechanical, fracture toughness, weathering, and welding properties of a new “super” weathering (SW), cost-competitive steel for transportation infrastructure applications. The new steel’s compositions were modifications of the composition of an ASTM A710 Grade B 70-ksi-yield, copper-precipitation-strengthening, hot-rolled, and air-cooled steel, previously developed at Northwestern University, that showed excellent fracture properties at low temperatures and a corrosion loss about 40% less than that in A709 HPS70W steel (as measured in automotive accelerated SAE J2334 test at Bethlehem Steel/Arcelor Mittal). To increase the weatherability of steel phosphorus appears to be the most potent element to enhance the corrosion resistance of steel. However, phosphorus also increases the steel’s brittleness. Consequently, addition of phosphorus to A710 Grade B steel (developed previously at Northwestern University) and mitigation of the steel embrittlement by addition of a specific amount of titanium to keep phosphorus from migration to the grain boundaries was the approach taken in this IDEA project. Other elements, such as chromium and molybdenum, which enhance steel weathering, were also added. Four SW steels were designed and tested. The steels were very ductile and fracture-tough to -100°F , thus significantly outperforming the requirements of ASTM A709 bridge steel standard (Figure 1). No brittle heat-affected zone was formed as a result of high-power laser welding simulation, thus indicating that the steels could be easily welded without pre- or post-welding heat treatment. Accelerated studies indicated that the developed steels have better weathering characteristics than A588 weathering steels that are currently used for bridge construction. The production of these new steels does not require special processing or thermal treatment; therefore, these steels can be produced by any steel manufacturer in any steel plate sizes. (Final Report NTIS # PB2015-100844)

Figure 1

Charpy absorbed fracture energy of experimental super-weathering steels.

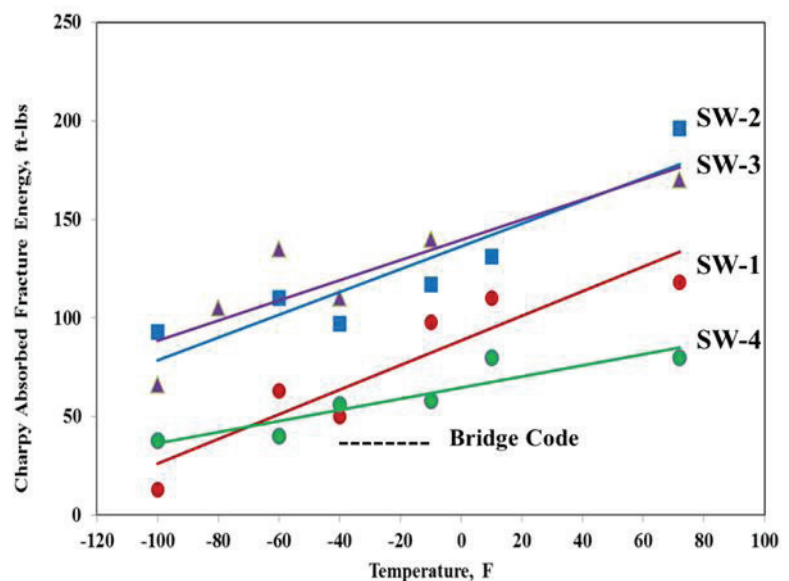

TOOLS FOR DETERMINING YIELD STRESS OF IN-SERVICE GUSSET PLATES

NCHRP-IDEA Project 161

Therese Pflaum and Christopher Higgins [Tel.: (541) 737-8869, Fax: (541) 737-3052, Email: chris.higgins@oregonstate.edu] Oregon State University, Corvallis, Oregon

The project developed and tested a prototype device to nondestructively assess the yield stress of steel gusset plates for use in bridge evaluation and rating. The prototype device is fabricated from titanium, which has very high strength and relatively low weight to facilitate field portability. The hand-held device uses a manually actuated hydraulic cylinder to apply an out-of-plane load to the free edge of a steel plate. The applied load, measured with a load cell, creates bending deflection of the plate that is measured with a displacement sensor. The applied load and plate displacement measurements are collected with a portable data acquisition system. Both the prototype device and data collection system are self-contained and require no external power source. This portability allows a bridge inspector to collect and analyze data in the field. The acquired load and deformation data are used to estimate the yield stress as the deflections become nonlinear at the onset of plate yielding. The load and deformation responses are calibrated to finite element (FE) analyses and empirical reference tests. Based on statistical analysis of results with the prototype device over a range of plate materials and thicknesses, a yield stress reduction factor of 0.85 was developed to ensure that the predicted yield stress would not exceed the actual yield stress with 1/10,000 probability when three (3) replicate tests are performed. The device is capable of testing mild steel plates up to 1 in. thick. After testing, there are imperceptible residual displacements on the plate at the defined yielding threshold. These characteristics provide a nondestructive method to estimate the yield stress of bridge steel plates in the field, which was previously not possible and as such may be a technological breakthrough. (Final Report NTIS # PB2015-102648)

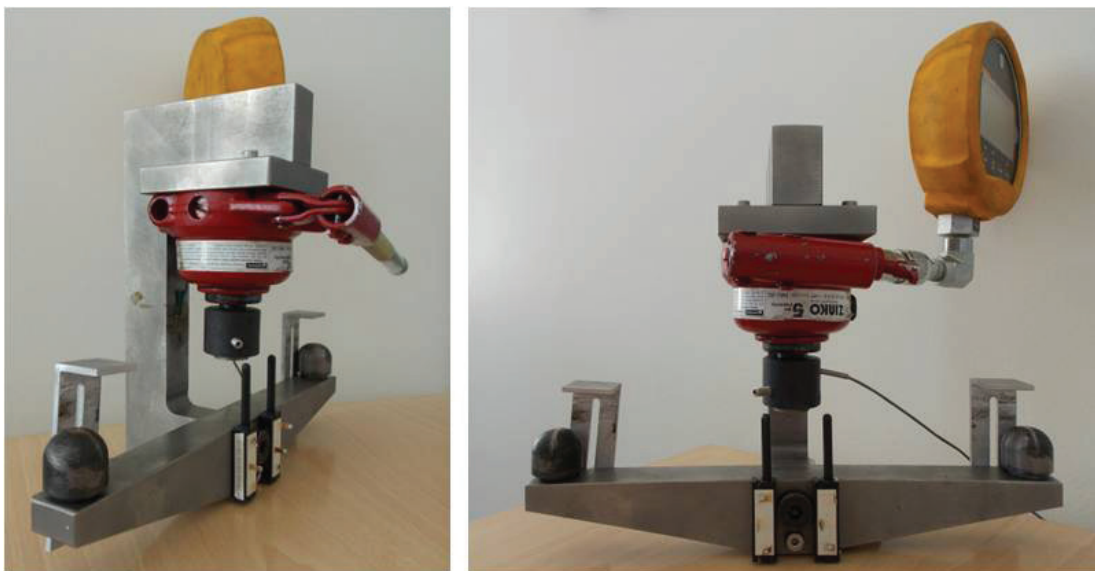

Figure 1

Prototype device used to bend plates at free edge.

FULL-SCALE PROTOTYPE TESTING AND MANUFACTURING AND INSTALLATION PLANS FOR NEW SCOUR-VORTEX-PREVENTION scAUR AND VorGAUR PRODUCTS FOR A REPRESENTATIVE SCOUR-CRITICAL BRIDGE

NCHRP-IDEA Project 162

Roger L. Simpson [Tel.: (540) 961-3005; Email: rogersimpson@aurinc.com]
Applied University Research (AUR), Inc., Blacksburg, Virginia

This project tested and developed manufacturing and installation plans for scAUR and VorGAUR products for scour-critical bridges to demonstrate their effectiveness in preventing scour-causing vortical flow characteristics at piers and abutments. Plans were developed and refined for the manufacture and installation of full-scale scAUR and VorGAUR products on a scour-critical bridge in Virginia, representative of scour-critical bridges across the United States. Reynolds number and bridge pier and abutment size effects were examined using computations that showed that scAUR with VorGAUR was effective in preventing scour-causing vortical flow at both model and full scale. Data on the performance of these products with several smaller size sediments at model scale were obtained in the AUR flume. No scour was observed around the scAUR with VorGAUR model for any gravel in this range. The performance of scAUR and VorGAUR concepts for a larger class of abutments was examined in model scale AUR flume tests. Wing-wall (Figure 1) and spill-through abutment flume models, with and without scAUR and VorGAUR features, were tested to show that the product features prevented scour for these abutments. A full-scale scAUR and VorGAUR pier model was constructed and tested under various conditions in the large flume at the Iowa Institute for Hydraulic Research (Figure 2) with results comparable to results for 1/7 size models in the AUR flume. Manufacturing methods and installation processes for scAUR and VorGAUR products were refined and plans and cost estimates for manufacturing full-scale products were developed. A cost-effective manufacturing alternative for a scAUR retrofit bridge pier or abutment fairing is to use stainless steel (SS) or weathering steel rather than shotcrete or precast concrete. Its corrosion resistance gives it a lifetime of 100 years even in seawater environments. The present value cost of these products over the life of a bridge is an order of magnitude cheaper than current scour countermeasures. (NTIS Report # PB2014-104002)

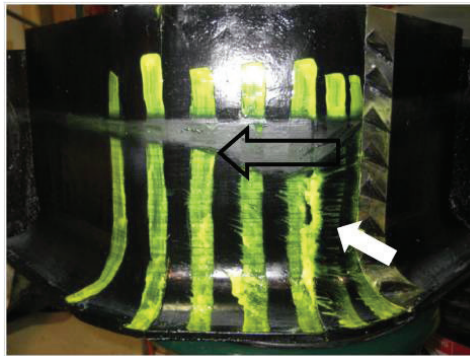

Figure 1

Wing-wall abutment with a scAUR fairing with VorGAUR™ vortex generators that move lower speed flow up the abutment.



Figure 2

Full-scale scAUR with VorGAUR vortex generators model in the Iowa Institute for Hydraulic Research Flume facility.

DEVELOPMENT OF AN ASPHALT PAVEMENT RAVELING DETECTION ALGORITHM USING EMERGING 3-D LASER TECHNOLOGY AND MACROTEXTURE ANALYSIS

NCHRP-IDEA Project 163

Yichang (James) Tsai [Tel.: (404) 894-6950, Email: james.tsai@ce.gatech.edu]

Georgia Institute of Technology, Atlanta, Georgia

Raveling is one of the pavement distresses that deteriorates in an exponential manner and requires identification at its earliest stage so that pavement preservation can be programmed in a timely manner. This project developed algorithms to automatically detect raveling using emerging 3-D line laser imaging technology (Figure 1). The algorithm was tested and validated using Georgia DOT pavement condition survey protocol on Interstates I-85 and I-285 near Atlanta, Georgia. The 3-D pavement data were collected on four test sections on I-85 (each 1 mile long) and on the entire outer lane of asphalt pavement (61 miles) on I-285. Tests on I-285 also showed promising results for automatic raveling detection, classification, and measurement. All pavements (with or without raveling) were 100% correctly detected and classified at the segment level (each segment 1 mile long). However, due to the difficulty of correctly labeling all the raveling areas using videolog images and 3-D pavement data and due to the impact of cracking and flat-tire scratches, the raveling extent showed some variation in comparison with the manually labeled ground truth. However, the differences between the surveyed results and the automatically detected and measured results were less than 15%. While the developed algorithms show much promise, further field evaluation is needed for implementation of the method by the departments of transportation. (Final Report NTIS # PB2017-101835)

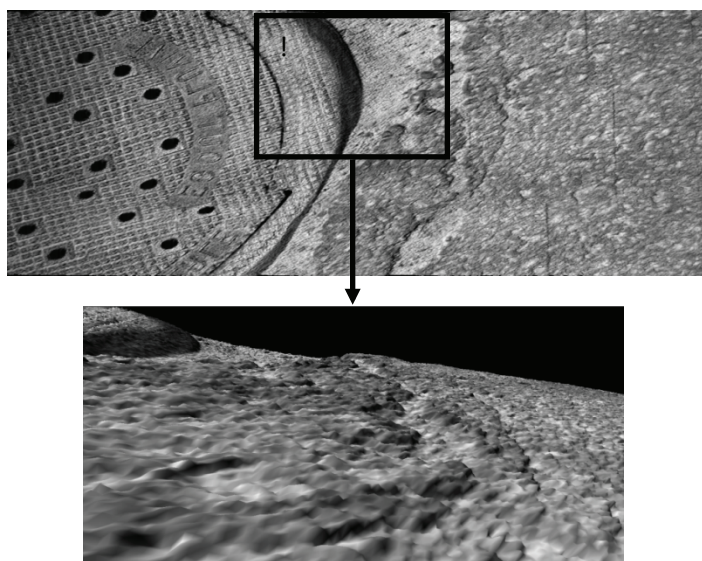

Figure 1

Visualization of 3-D pavement surface data for analyzing loss of stones.

LASER SPECTROSCOPY FOR RAPID PROFILING OF STEEL BRIDGE COATING, CORROSION, AND HEAVY METALS

NCHRP-IDEA Project 164

Warren Chesner [Tel.: (516) 431-4031, Fax: (516) 717-2621, Email: wchesner@chesnerengineering.com] Chesner Engineering, P.C., Long Beach, New York

The project was designed to develop and demonstrate the application of a laser scanning technology to rapidly identify and profile the presence of heavy metals (Pb, Cd, and Cr) and titanium (Ti) in paint coatings. In addition, the potential for using laser scanning to identify the type of coating used and the presence and the severity of corrosion under layers of coatings on steel structures was investigated. Finally, special testing was undertaken to evaluate the use of laser equipment to drill through and depth-profile coating layers. Findings have shown that laser spectroscopy readily distinguishes coatings with high levels of Pb, Cd, and Cr from coatings with minimal levels. The presence and concentration of titanium present in coatings is readily identifiable. Zinc-rich coatings are easily distinguishable from other coatings and epoxies. Study findings also showed that it is possible to distinguish between degrees of corrosion. The research team developed and successfully tested a combined drilling and laser ablation tool to achieve a high-resolution depth profile of coating layers (Figure 1). Such a tool has applicability as a research tool as well as a field inspection tool to assess the presence of coatings containing high levels of heavy metals, the thickness of the coatings, the type of coating, and level of corrosion at the surface and under the coating layers. The depth profiling technology featured in this research has the potential for use as a diagnostic tool in a variety of structures including concrete, asphalt, and steel surfaces.

Future activities will require further development of the design basis for the fabrication and deployment of a commercial prototype, and testing the depth profiling capacity of the system using other materials. (Final Report NTIS # PB2016-100670)

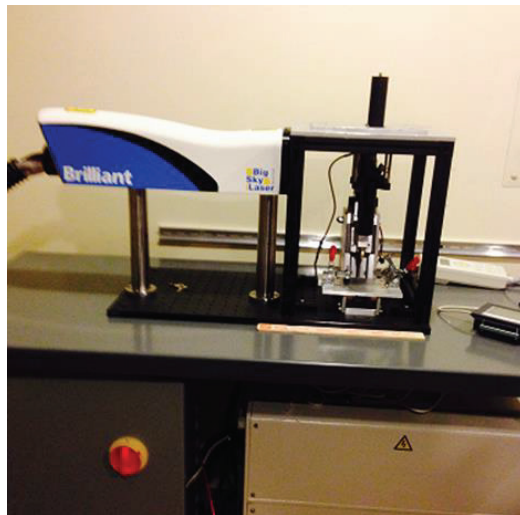

Figure 1

Micro-drill depth profiling laser system.

BATTERY-LESS WIRELESS WEIGH-IN-MOTION SENSOR

NCHRP-IDEA Project 165

Rajesh Rajamani [Tel.: (612) 626-7961, Fax: (612) 625-4344, Email: rajamani@me.umn.edu]
University of Minnesota at Twin Cities, Minneapolis, Minnesota

The goal of this project was to develop a battery-less wireless weigh-in-motion (WIM) sensor and a smart phone app that wirelessly received information from the sensor to display the weight of each passing vehicle. The WIM sensor utilized a previously developed vibration energy harvesting system that obtained all energy required for its operation from the vibrations of each passing vehicle. Building on previous work, this project developed two new rigid WIM sensor designs, an all-metal casing for sensor operation, and a smart phone app for wireless access to the sensor signals. Figure 1a shows the open sensor enclosure box and Figure 1b shows the sensor inside the box grouted to the asphalt pavement.

The sensor was evaluated at the Minnesota Road Research Facility (MnRoad) in an asphalt pavement using a number of different types of vehicles. The WIM system provided weight measurements that increased monotonically with increasing axle weights, but showed significant variability from one test to another for the same vehicles and the same axle loads. Vibrations measured on the truck axles showed low vibrations at 10 mph and high vibration levels reaching up to 500 mg rms at 50 mph. Since significant variability in measured axle weights was seen even at 10 mph, it was concluded that the measurement variability was not purely the result of truck suspension vibrations. The variability was diagnosed to be due to the sensor enclosure box, which provided variability in load depending on the lateral position of the vehicle in the lane. The variability issue made the sensor unreliable for field testing and therefore further work on the project was discontinued. (Final Report NTIS # PB2016-100671)



Figure 1a

A box enclosure for installation of sensor inside pavement.

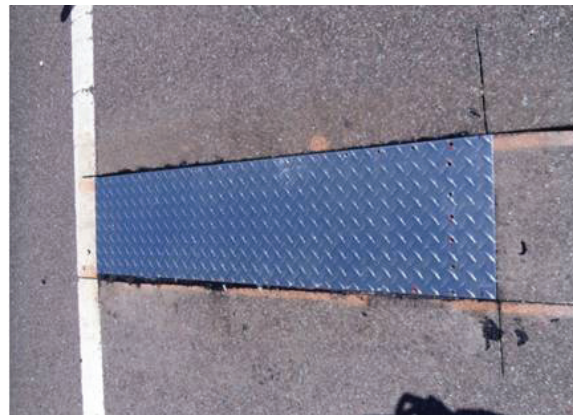

Figure 1b

Photograph of sensor in external box that has been grouted in asphalt pavement.

GUIDELINES FOR THE USE OF WASTE CONCRETE FINES

NCHRP-IDEA Project 166

Julie Vandebossche [Tel.: (412) 624-9879, Fax: (412) 624-0135, Email: jmv7@pitt.edu]
University of Pittsburgh, Pittsburgh, Pennsylvania

Donald Janssen [Tel.: (206) 543-9655, Fax: (206) 543-1543, Email: dnjan@msn.com]
University of Washington, Seattle, Washington

This project developed guidelines for using waste concrete fines (and the associated wastewater) in concrete by developing methods to rapidly characterize fines samples and evaluating the performance of concrete using these recycled materials. Unfortunately, a considerable amount of wastewater with high pH, as well as dissolved and suspended solids, is associated with concrete production (clean-up), the rehabilitation of concrete structures, and the recycling of concrete at the end of the structure's life (Figure 1). Sources of recycled fines were identified and the fines were characterized after mixing them with water to create solutions and suspensions and their indices of refraction, pH, and conductivity determined. Mortar samples were prepared and their setting times and strengths measured for a range of fines particle sizes and contents. Correlations were established from the collected data to help develop a performance-prediction model for different recycled fines materials. This model was used to develop guidelines for using recycled concrete fines in new concrete mixtures. In the next step, a water recirculation system was constructed, which incorporated in-line (continuous reading) sensors for measuring the index of refraction, conductivity, and pH. Waste materials were added to the recirculation system and evaluated using the in-line sensors to validate the implementation plan and the model. The implementation plan for ready-mix concrete producers when upgrading plants with in-line sensors was finalized along with instructions on applying the guidelines for using recycled fines. Work has continued beyond the IDEA project with support from Northwest Regional Transportation Center. Sensors were installed in the recycled water recirculation system at the Stoneway Concrete plant in Seattle, Washington. Mixtures with recycled and "city water" were tested and strength test results compared with predictions from the IDEA developed models. Results were presented to the Seattle Department of Transportation (DOT), City of Seattle Department of Planning and Development, and Washington State DOT as part of the implementation effort. (Final Report NTIS # PB2017-101836)

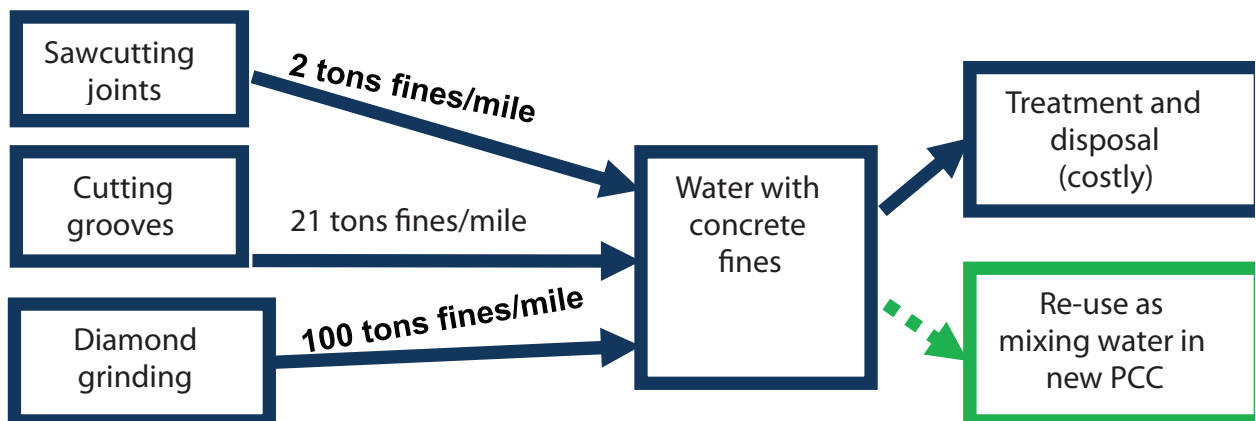

Figure 1

Sources of recycled concrete fines and the rate at which they are generated.

EXPLORATORY ANALYSIS OF AUGMENTED REALITY VISUALIZATION FOR RIGHT-OF-WAY EXCAVATION SAFETY

NCHRP-IDEA Project 167

Vineet R. Kamat [Tel.: (734) 764-4325, Fax: (734) 764-4292, Email: vkamat@umich.edu]
University of Michigan, Ann Arbor, Michigan

This project developed a prototype system for georeferenced augmented reality visualization of buried utility geospatial data and real-time monitoring of an excavator's proximity to buried utilities in its vicinity (Figure 1). A graphics algorithm to place virtual 3D buried utility models in an augmented scene was designed as well as 3D machine control system for monitoring an excavator's pose in real time during excavation operations. The research methodology involved three stages: tracking, representing in 3D, and analysis. The technical feasibility of a fiducial marker-based end effector pose estimation system was experimentally evaluated for excavators, and its performance demonstrated to consistently estimate bucket tooth position within 2.5 cm (1 in.) of absolute error. The accuracy of the pose estimation was primarily dependent on camera calibration, marker corner detection, and marker rig precision. A multi-plane 3D camera calibration method using an affine transformation model was designed. A stereo marker rig was also designed along with a method to compare the camera pose estimation with the ground truth. Finally, algorithmic optimizations were designed to overcome some of the factors that contribute to the uncertainty of corner detection in fiducial markers. It was also found that in the outdoor environment the bright sunlight illuminance complicates the marker detection, but its negative effect can be canceled by automatic exposure. These improvements lead to significant performance improvements in stereo fiducial marker detection at large scales. A working prototype was tested on several active construction sites with positive feedback from excavator operators confirming the solution's effectiveness. (NTIS Report Number: PB2017-101837)

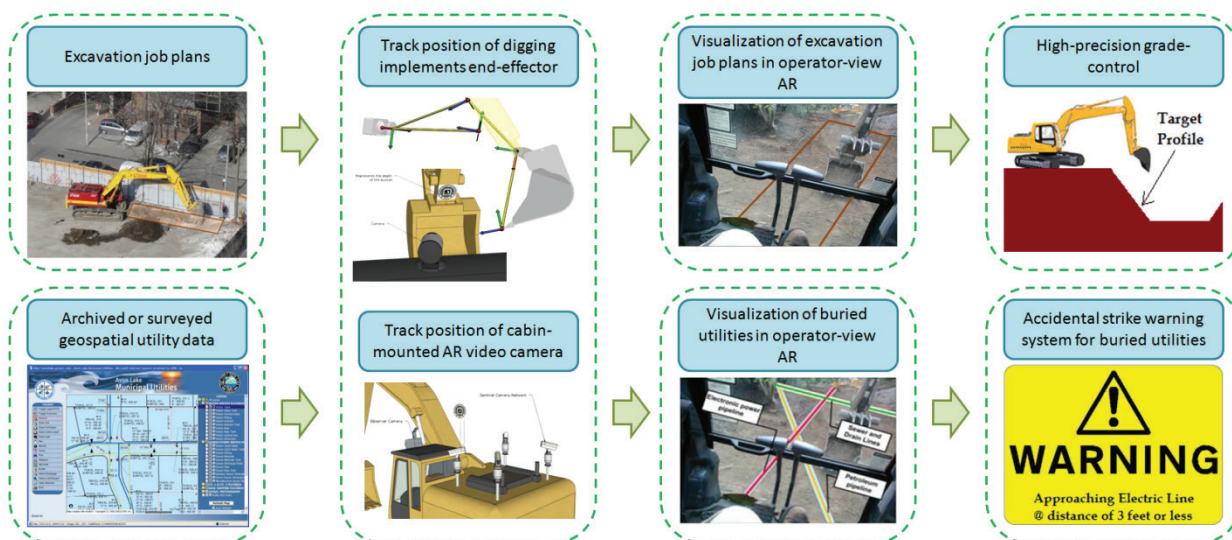

Figure 1

Augmented reality visualization of geospatial utility data: precise grade-control (above) and utility avoidance (below).

AUTOMATED AND CONTINUOUS AGGREGATE SAMPLING AND LASER TARGETING SYSTEM: PROTOTYPE DEVELOPMENT

NCHRP-IDEA Project 168

Warren Chesner [Tel.: (516) 431-4031, Fax: (516) 717-2621, Email:

wchesner@chesnerengineering.com] Chesner Engineering, P.C., Long Beach, New York

This project was aimed at developing and demonstrating the field application of an automated real-time, quality control, aggregate laser scanning monitoring system developed in an earlier project (NCHRP-150). Figure 1 illustrates the concept. The system, referred to as the sampling and laser targeting system (SLT), consists of a laser, a spectrometer, a fiber optic cable, mirrors and lenses, a housing with a ventilation system, and a laptop computer to monitor aggregate materials introduced into the system. The SLT system works by focusing a high-powered laser at flowing aggregate materials and recovering and analyzing the light generated in this process. The recovered light provides a unique fingerprint of the target material. Aggregate materials received from several state departments of transportation, including Kansas, Oklahoma, Pennsylvania, Ohio, and New York, were scanned. A special software was developed to analyze spectral data generated during laser scans. The results suggest that laser scanning and multivariate analysis of spectra generated using the SLT could predict values of acid insoluble residue, specific gravity, micro-Deval, D-cracking, and percent chert in the aggregates tested. A key conclusion of this research is that laser scanning of aggregate is a technology capable of altering the manner in which aggregate quality control procedures are employed by the industry in the future. The system, which has been granted a U.S. patent, is being demonstrated at a quarry near Albany, New York, and is further evaluated in a pooled fund study sponsored by several states (Ohio, New York, Kansas, Oklahoma, and Pennsylvania). A draft Standard of Practice or a Test Method on the laser scanning technology has been prepared for consideration by AASHTO. (Final Report NTIS # PB2017-101838)

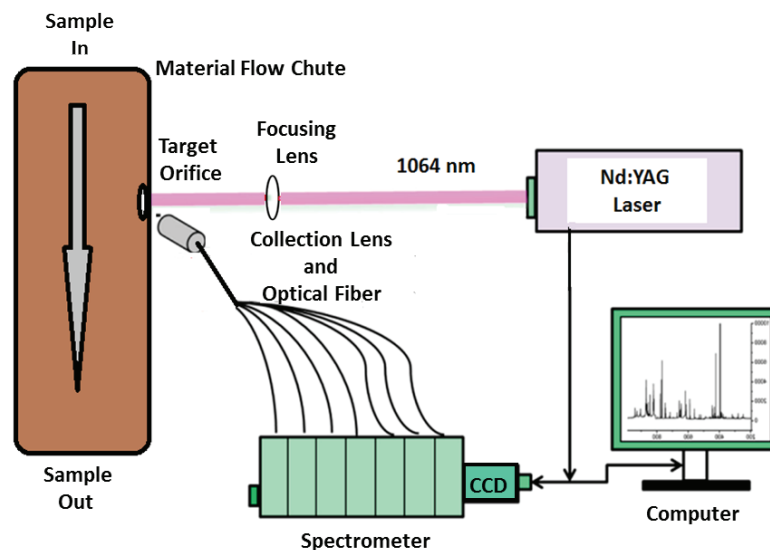

Figure 1

Sampling and laser targeting system concept.

AN INEXPENSIVE VISION-BASED APPROACH FOR THE AUTONOMOUS DETECTION, LOCALIZATION, AND QUANTIFICATION OF PAVEMENT DEFECTS

NCHRP-IDEA Project 169

Burcin Becerik-Gerber [Tel.: (213) 740-4383, Fax: (213) 744-1426, Email: becerik@usc.edu]

Sami F. Masri [Tel.: (213) 740-0602, Fax: (213) 744-1426, Email: masri@usc.edu]
 University of Southern California, Los Angeles, California

Mohammad R. Jahanshahi [Tel: (765) 494-2217; Fax: (765) 494-0395;
 Email: jahansha@purdue.edu] Purdue University, West Lafayette, Indiana

The goal of this project was to develop and demonstrate the application of an imaging system based on inexpensive sensors for an automated detection and quantification of pavement defects, including cracks and potholes. Figure 1 provides an overview of the imaging/inspection system. The approach used off-the-shelf Microsoft Kinect, costing under \$200, to collect color images and 3D point clouds of roadway surfaces. A compact-size pavement data collection system was built that could be easily installed on a car and collect data at highway speeds. The system used multiple Microsoft Kinect sensors to cover a lane width and was designed to reach scanning speed. It also included 3-axis accelerometers to record orientations of the system and Global Positioning System to obtain location and velocity. Several road tests were performed on local streets and freeways. The tests presented a few challenges. The main challenges were sunlight interference, motion blur, and rolling shutter distortion. A top cover was designed to reduce the sunlight interference. A stroboscopic technique was used to solve the motion blur problem for Kinect's color image acquisition and capture slow motion pictures. A rectification algorithm was developed to correct distorted images. These improvements enabled the pavement data collection system to obtain good imaging results when moving at less than 30 mph (residential speed limit in most states). Furthermore, pavement crack detection using a hybrid algorithm based on anisotropic diffusion filtering and eigenanalysis of Hessian matrix showed a promising outcome in segmenting the cracks as compared with a modified bottom-hat morphological method. Further improvement and evaluation are needed before the system would be implementable by the state departments of transportation. (Final Report NTIS # PB2017-101839)

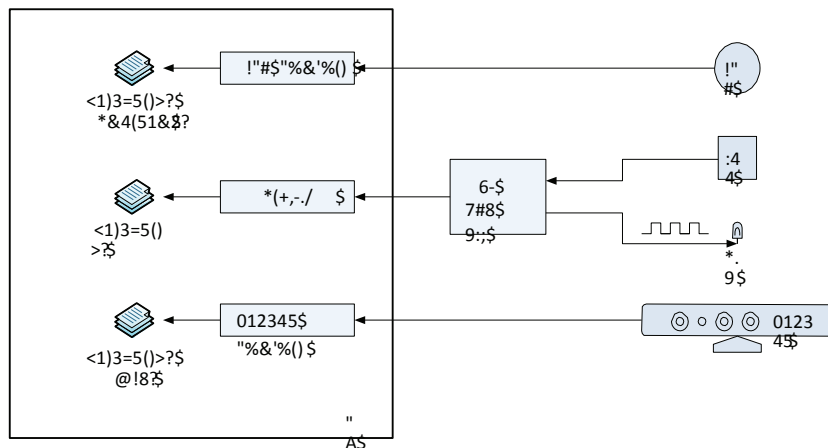

Figure 1

Overview of the 3D scanning system for pavement inspection.

DEVELOPMENT AND IMPLEMENTATION OF THE ASPHALT EMBRITTLEMENT ANALYZER

NCHRP-IDEA Project 170

William G. Buttlar [Tel.: (217) 333-5966, Fax: (217) 333-1924, Email: buttlar@illinois.edu]
University of Illinois, Urbana-Champaign, Illinois

Henrique M. Reis [Tel.: (217) 333-1228, Fax: (217) 244-5705, Email: h-reis@illinois.edu]
University of Illinois, Urbana-Champaign, Illinois

Behzad Behnia [Tel.: (217) 7214842, Fax: (413) 782-1576, Email: behzad.behnia@wne.edu]
Western New England University, Massachusetts

This project developed an asphalt embrittlement temperature detection system, referred to as the asphalt embrittlement analyzer (AEA), to rapidly and reliably characterize the asphalt material embrittlement threshold at various pavement depths using small-diameter field cores (Figure 1). Working with collaborating industrial partners (Troloxer, Inc., Road Science, and Asphalt Institute), a temperature-controlled device coupled with multi-channel AEA and software was completed to calculate T_{EMB} vs. depth and a prototype AEA system for commercialization was designed. A series of maintenance strategies and an expert system to guide designers toward an optimally designed rehabilitation strategy were also developed.

The prototype AEA device, now capable of measuring graded in situ embrittlement characteristics, is ready for final commercialization. This will likely involve field validation across a broad range of materials and climates across the United States, vetting through the FHWA mixtures expert task group, development of an AASHTO test standard, round robin testing, and finalization of commercial equipment based data and experience from these subsequent efforts. (Final Report NTIS # PB2016-100672)

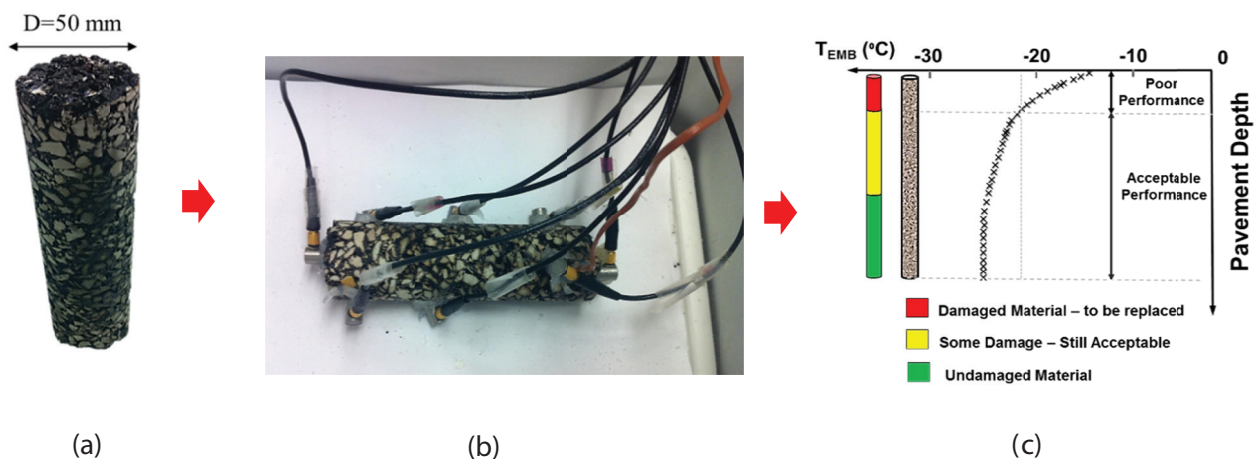

Figure 1

Continuous embrittlement temperature property characterization of age-graded field core materials: (a) 50-mm diameter field core sample, (b) AEA sensing system mounted on mixture sample, and (c) real-time graphical display of embrittlement temperature profile throughout the pavement thickness.

PRODUCING A SUSTAINABLE AND BIO-BASED ALTERNATIVE FOR PETROLEUM-BASED ASPHALT

NCHRP-IDEA Project 171

Elham Fini [Tel.: (336) 285-3676, Fax: (336) 334-7126, Email: efini@ncat.edu]

Shahrzad Hossein Nezhad [Tel.: (336) 809-2121, Email: sh.hosseinnezhad@yahoo.com]

Amadou Bocoum [Tel.: (336) 334-7737, Email: ambocoum@aggies.ncat.edu]

North Carolina A&T State University, Greensboro, North Carolina

The project was aimed at developing and characterizing a bio-asphalt based on swine manure and crumb rubber for highway construction application. The bio-binder reacts with the surface of rubber particles. Bio-asphalts with higher percentages of bio-adhesive overall showed enhanced rheological properties and the level of improvement was highly dependent on the rubber content. Addition of bio-adhesive to rubberized asphalt involved three phases: lubrication, surface treatment, and dilution. To optimize the use of bio-adhesive, its content needed to be designed to maximize rubber surface treatment while avoiding dilution. The most suitable bio-modified rubber (BMR) asphalt studied in this project was when 20% rubber was treated by 20% bio-binder (by weight of asphalt binder). Mechanical tests showed significant improvement in BMR properties as compared to non-modified specimens both at low and intermediate temperatures. Also, the level of compaction energy required for BMR specimens was relatively lower than those of non-modified specimens indicating better mixture workability of BMR specimens. BMR mixtures had lower mixing and compaction temperatures with the same mixture design (aggregate gradations, compaction energy and target air void). BMR and crumb rubber modified without bio-binder (CRM) samples showed better rutting resistance in Hamburg wheel tester compared to neat asphalt mixture samples. BMR samples took more energy to fracture during DC(T) fracture tests compared to both CRM and neat samples (Figure 1). The indirect tensile IDT modulus of BMR samples was also found to be lower than CRM samples. During creep tests at low temperatures (0°C, -12°C, and -24°C), BMR samples were found to have higher creep compliance than both neat and CRM samples. (NTIS Report Number: PB2017-102160)

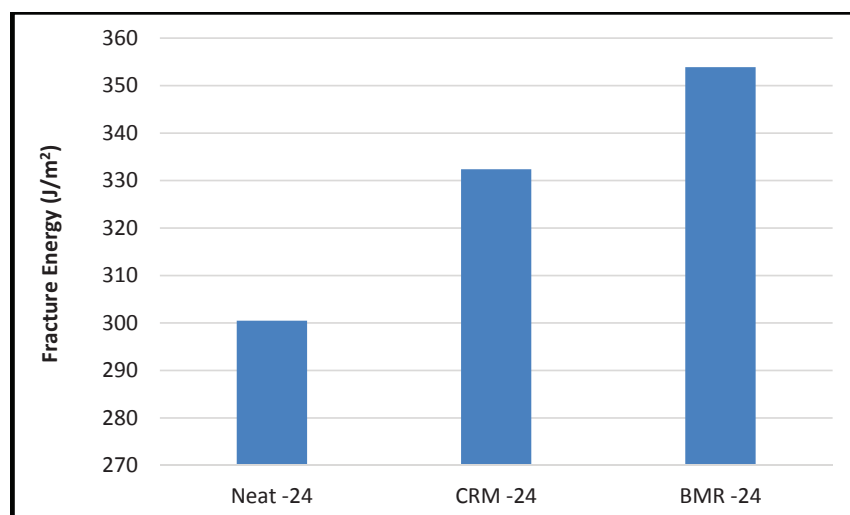

Figure 1

Comparison of DC (T) fracture energy results among neat, CRM, and BMR mixtures at -24°C.

BIDIRECTIONAL-DUCTILE END DIAPHRAGMS FOR SEISMIC PERFORMANCE AND SUBSTRUCTURE PROTECTION

NCHRP-IDEA Project 172

Michel Bruneau [Tel.: (716) 645-3398, Fax.: (716) 645-3733, Email: bruneau@buffalo.edu]

Xiaone Wei [Email: xiaonewe@buffalo.edu]

Luna Ngeljaratan [Email: lunangel@buffalo.edu] University at Buffalo, Buffalo, New York

This project developed bi-directional ductile diaphragms for straight and skewed bridge superstructures to provide resistance to bidirectional earthquake excitations (Figure 1). The proposed ductile end diaphragm systems (EDS) were designed for benchmark skew and nonskew bridges and analyzed using nonlinear time history analysis to examine their seismic performance. A design procedure for the EDS in skew bridges was developed based on the analysis results. The long-term service life of EDS installed across expansion joints and subjected to bridge thermal expansion histories was also investigated and a minimum ratio of the Buckling Restrained Brace (BRB) length over the whole bridge length was recommended. Quasi-static experiments were conducted to subject BRB to a regime of relative end-displacements representative of the results predicted from parametric analytical studies. A test set-up was developed, which consisted of connecting the BRB from the strong floor to a shake table in the SEESL. All BRB specimens tested developed a cumulative inelastic displacement of more than 200 times the BRB's axial yield displacement, which is the threshold of inelastic performance specified by the AISC as part of its acceptance criteria for BRBs. The specimens could also sustain multiple years of severe temperature cycles while meeting the prequalification criterion. No end-plate failure or instability was observed. Following the tests, some BRBs were opened. It was found that fracture typically occurred where the BRB's core plate locally buckled the most. (NTIS Report Number: PB2017-102161)

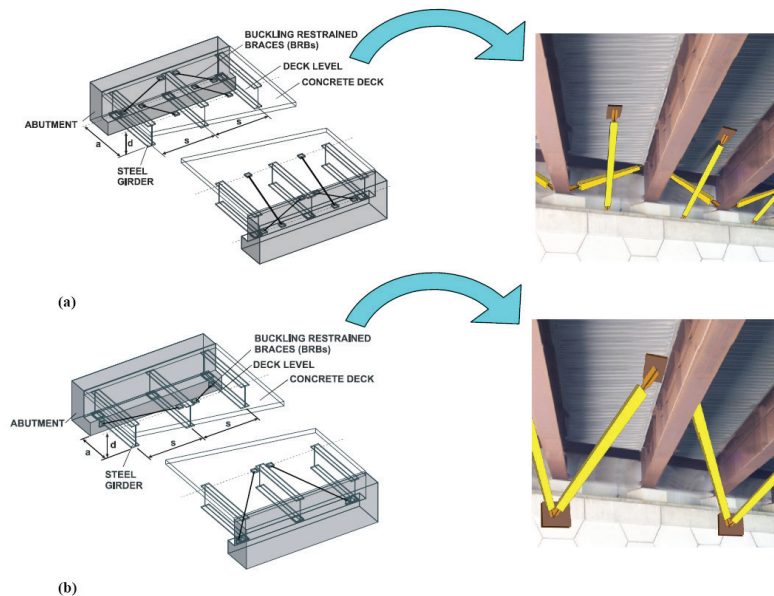

Figure 1

Proposed schemes for bridge ductile end diaphragms: (a) end diaphragm system-1 (EDS-1); (b) end diaphragm system-2 (EDS-2).

GRAPHENE NANO-PLATELET (GNP) REINFORCED ASPHALT MIXTURES: A NOVEL MULTIFUNCTIONAL PAVEMENT MATERIAL

NCHRP-IDEA Project 173

Jialiang Le [Tel.: (612) 625-0752, Fax: (612) 626-7750, Email: jle@umn.edu]

University of Minnesota, Minneapolis, Minnesota

This project developed and tested asphalt binders and mixtures reinforced with graphene nano-platelets (GNP) as a multifunctional pavement material. Mechanical properties of GNP-reinforced asphalt binders and mixtures were evaluated. A detailed method for material preparation and a quantitative analysis of the effect of GNP on the mechanical properties of asphalt binders and mixtures was developed. GNP was found to mix with asphalt binders without major dispersion problems. Binder and mixture specimens prepared with different amounts of GNP were subjected to complex modulus test, indirect tension creep and strength tests, and fracture test at low temperature. The tests showed that the addition of GNP greatly enhanced the flexural strength of asphalt binders at low temperatures, moderately improved the creep stiffness, and had no adverse effects on relaxation properties. It was also observed that, compared to conventional asphalt mixtures, GNP-reinforced asphalt mixture specimens exhibited better cracking resistance in terms of strength and fracture energy. However, GNP addition did not improve the electrical conductivity of the asphalt materials. Compaction process of GNP-reinforced asphalt mixtures was also investigated. The addition of GNP significantly reduced the number of gyrations needed to compact the mixtures to a target air void ratio. The reduction ranged from 15% to 40% for different mix designs. Furthermore, the GNP allowed successful compaction at a lower temperature. A series of rut experiments was also performed on GNP-reinforced asphalt mixtures in collaboration with the Minnesota DOT. GNP addition improved the rut performance of the mixtures (Figure 1). A patent for the GNP-based product has been obtained. Work on implementation GNP in actual pavement application is to be done in collaboration with Minnesota DOT. (Final Report NTIS # PB2017-102162)

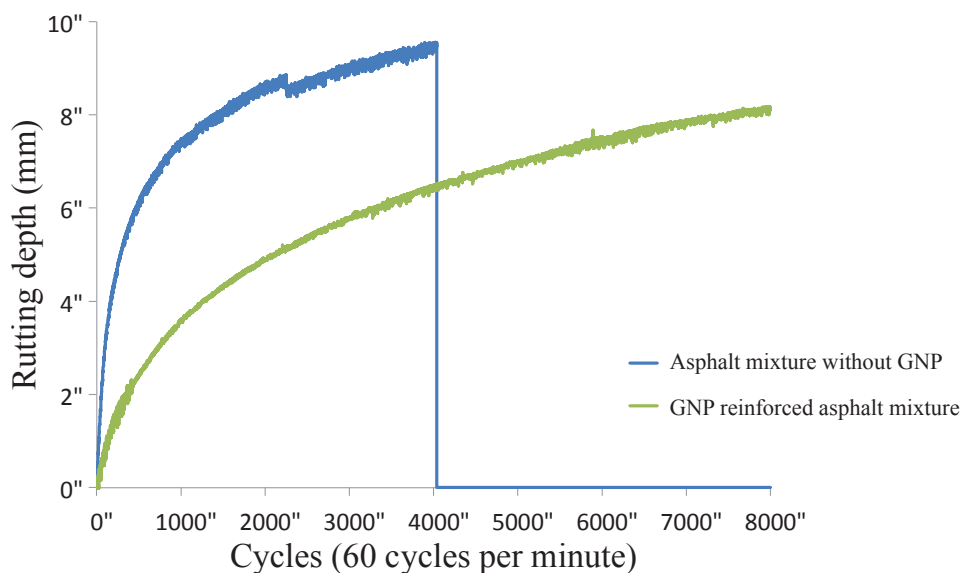

Figure 1

Rutting performance of GNP-reinforced asphalt mixtures.

ENHANCED PERFORMANCE ZINC COATING FOR STEEL IN CONCRETE

NCHRP-IDEA Project 174

Neal Berke [Tel.: (269) 384-9980, Fax: (269) 384-9981, Email: nberke@tourneyconsulting.com]
Tourney Consulting Group, LLC, Kalamazoo, Michigan

The objective of this project was to evaluate thermal zinc diffusion (TZD) coatings for improved corrosion resistance for concrete reinforcing bar as compared with commercial coatings currently in use. Corrosion performance was determined, using standard ASTM test methods, in good quality concrete [lower water-to-cement ratio (w/c) and higher cover] cracked in flexure with periodic loading to abrade the coatings, in order to capture the two predominant failure mechanisms for coated steels. Both straight and bent bars were evaluated, as well as another set of U-bend specimens for stress corrosion. Steels evaluated were black steel, hot-dipped galvanized (HDG) steel, epoxy-coated steel (ECR), 2304 Stainless Steel (SS), low-chromium ASTM 1035 steel, and the TZD-coated steel. An epoxy coating was manually applied to the TZD bars to evaluate a coated version of the product (TZE). The performance of the corrosion-resistant reinforcing bars was significantly better than the control black bars. The overall relative corrosion resistance ranking in the cracked beam test was:

Black Steel Bar < HDG < A1035 Low-Chromium < TZE \approx TZD < ECR, 2304 SS

The results indicate that TZD reinforcing steel could improve the corrosion performance of steel in concrete. For the U-bend specimens the HDG performed better than TZD, which may be due to higher w/c of concrete and lower cover that let chloride in too fast, preventing the TZD specimen to adequately form a protective passive coating. The HDG coating was thicker and had a chromate treatment, which helped it to passivate. The TZE bars had lower corrosion currents. The damage on the bars was comparable to the TZD in the beam test but did help in the U bend tests. The coating was not optimized (brushed versus fusion bonded, not formulated for concrete use), which implies that performance could improve with a commercially applied suitable coating. Based on the results of this study, further work with departments of transportation is recommended to initiate trial testing in the field. The cracked beam method (Figure 1) looks promising as a test method to evaluate corrosion-resistant reinforcing bars, high-performance concrete, surface treatments, and a combination of these. It might be useful to develop this flexural cracked beam test into an AASHTO provisional test method specification. (Final Report NTIS # PB2018-100050)



Figure 1

Large cracked beam corrosion specimens. Specimens are 6 x 6 x 20 in.

RAPID DETECTION OF FATIGUE CRACKING IN STEEL ANCHOR RODS USING THE IMPULSE RESPONSE METHOD

NCHRP-IDEA Project 175

Stephen Pessiki [Tel.: (610) 758-3494, Fax: (610) 758-5902, Email: pessiki@lehigh.edu]

Wesley Keller [Tel.: (610) 758-3525, Fax: (610) 758-5902, Email: wjk207@lehigh.edu]

Shamim Pakzad [Tel.: (610) 758-6978, Fax: (610) 758-5902, Email: pakzad@lehigh.edu]

Lehigh University, Bethlehem, Pennsylvania

This project developed a nondestructive impulse response test procedure for detection of fatigue cracks in steel anchor rods in auxiliary highway structures. This could serve as a rapid screening test able to detect the presence of a fatigue crack with greater reliability than visual inspection. A full-scale structure foundation anchorage assembly was constructed. To perform a test, an accelerometer was coupled to the top surface of an anchor rod, and the surface was struck with an instrumented hammer. Evaluation of the results for the purpose of damage identification involved measuring the variation in the normalized response signal from a known baseline (healthy or uncracked condition). To identify indicators of fatigue cracking, several damage sensitive features extracted from univariate and multivariate regression models were evaluated, including alpha-based regression coefficients, angle coefficients, cosh spectral distances, and regression residuals. Of these, alpha-based regression coefficients were found to be the most reliable indicators of anchor rod cracking. Autoregressive models (AR) that relate the current value of a predicted time series to past values of the same series were used to fit accelerometer recordings normalized by the applied impulse. From the test results, it was found that by establishing a baseline measurement for an uncracked rod and evaluating the change in Mahalanobis distance between the alpha coefficients ($D_m\alpha$) of regression models fitting the test data (Figure 1), the test method could identify artificial cracks at the base of the leveling nut (a region known to be susceptible to fatigue cracking), extending 1/4 and 1/2 of the rod diameter in depth, with at least 95% confidence. Repeatability was influenced by transducer-to-rod coupling conditions and by the consistency of the mechanical impact. (Final Report NTIS # PB2018-100051)

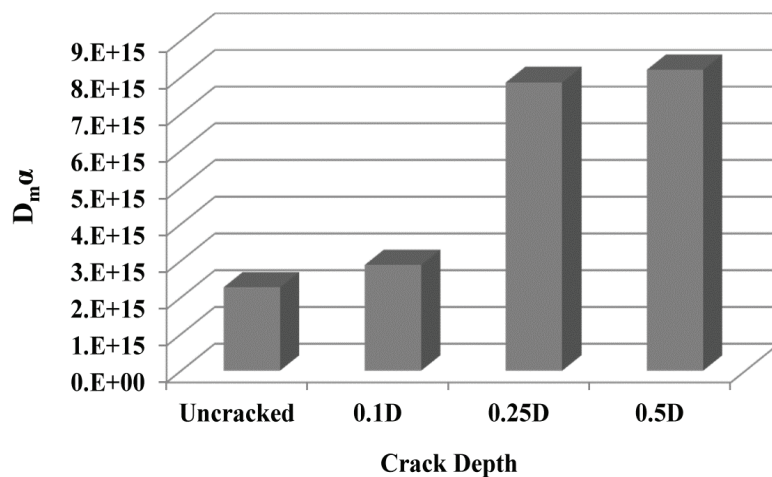

Figure 1

Mean Mahalanobis distance between the alpha coefficients of regression models fitting the P6 test data for various crack depths.

CONTACTLESS ELECTRODE FOR FAST SURVEY OF CONCRETE REINFORCEMENT CORROSION

NCHRP-IDEA Project 176

Alberto A. Sagüés [Tel.: (813) 974 5819, E-mail: sagues@usf.edu]
University of South Florida, Tampa, Florida

The project developed and demonstrated a Kelvin Probe (KP) electrode device for rapid and stable electrode potential mapping for early corrosion detection in concrete steel reinforcement in highway structures. An existing stationary miniature proof-of-concept version of a KP electrode device was scaled up to a mobile and practical large size unit suitable for realistic field conditions (Figure 1, left). Operation of the scaled up contactless vibrating probe on a mobile platform was demonstrated on an outdoor reinforced concrete slab. The acquired probe data created a potential map of the slab surface that successfully identified the position of the anodic spot (Figure 1, right). The rapid probe operation was validated against data obtained on the same surface using the traditional and slower contact electrode method. Performance parameters needed to acquire useful data under various vehicle speeds were analyzed, and a conceptual approach using an alternative non-vibrating translating disk to operate at even greater scan speeds was analyzed. A duplicate vibrating unit for testing the coordinated operation was constructed, incorporating an advanced distance transducer and consolidation of the digital processing units into a powerful signal acquisition unit. A post-scanning deconvolution of the KP output was implemented to sharpen the resulting surface potential map to allow for faster travel speeds. Evaluation of the mobile units was conducted in two field tests on a pier deck that had previously served as the Sunshine Skyway Bridge access. The tests demonstrated the practical feasibility of the concept of using a rapidly scanning contactless surface probe to conduct potential mapping of a highway bridge surface for corrosion detection. (Final Report NTIS # PB2018-100052)

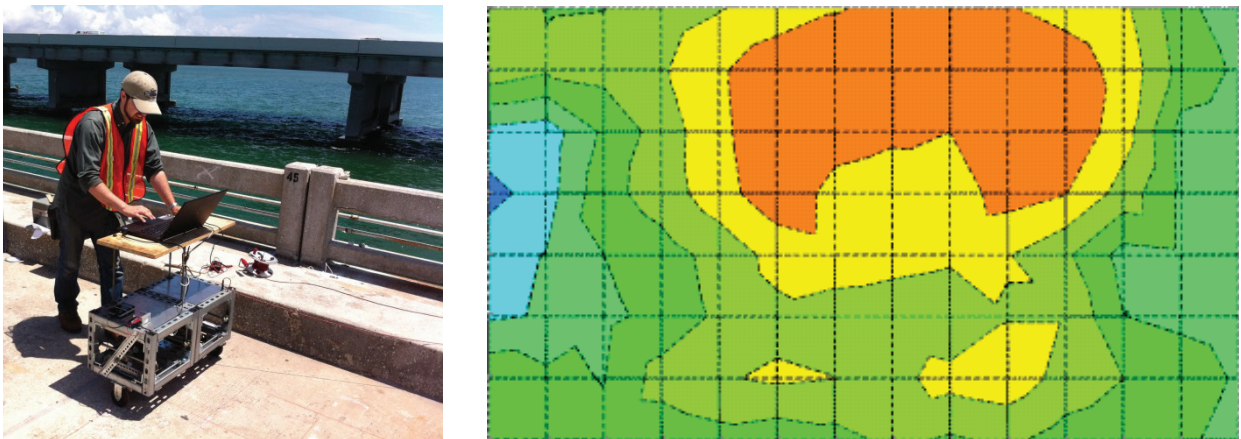

Figure 1

Left: Dual probe prototype (Patent Pending) in field tests on an aged Florida reinforced concrete bridge deck. Right: Potential map obtained by the contactless probe successfully spots rebar corroding region (roughly the orange area, with steel potential hundreds of mV more negative than places further away) on an $\sim 3 \times 5$ m deck portion. Results are consistent with traditional contact electrode measurements on the same portion.

AUTOMATED TURNING MOVEMENT COUNTS FOR SHARED LANES USING EXISTING VEHICLE DETECTION INFRASTRUCTURE

NCHRP IDEA Project 177

David A. Noyce [Tel.: (608) 265-1882; Fax: (608) 262-5199; Email: noyce@engr.wisc.edu]

Madhav Chitturi [E-Mail: mchitturi@wisc.edu]

Kelvin R. Santiago [Email: ksantiago@wisc.edu]

University of Wisconsin, Madison, Wisconsin

This project was aimed at demonstrating how vehicle trajectory data can be obtained from an existing radar-based vehicle detection system and used to produce turning movement count reports at signalized intersections with both exclusive and shared lanes. The most noteworthy impact of this work is the possibility of transforming every intersection equipped with radar-based detection (or any other system capable of monitoring vehicle trajectories) into an automatic traffic recorder that can log vehicle movements regardless of lane configuration. Vehicle trajectory data and video recordings were obtained at a main location in Appleton, WI and at two supplemental locations (Appleton, WI and Madison, WI). The supplemental locations were used to better understand how the data collection and algorithms developed perform under varying geometric conditions. An algorithm that processes vehicle trajectory data collected from a radar device and generates turning movement counts was developed and implemented in the R programming language. The algorithm relies on vehicle trajectories downstream of an automatically detected stop bar to classify vehicle movements into left, thru, and right movements. The actual number of vehicles was obtained by performing manual turning movement counts using intersection video. The stop bar position plays a key role in removing noise in the dataset such as vehicles in nearby parking lots. When the number of vehicles detected by the algorithm is compared with the number of vehicles from a manual count the results indicate an average accuracy of over 99%. A more detailed analysis suggests that the average difference between the number of vehicles classified as making a specific movement during a 15-minute period and the actual number of vehicles in the same period is ± 2 in over 60% of the periods evaluated. The evaluation of the algorithm performance in 15-minute intervals, regardless of traffic volumes, provides a more intellectually-honest evaluation of the results by moving away from the standard practice of reporting vehicle detection system performance using large volumes and ignoring turning movement breakdown. Coincidentally, when the performance of the developed algorithm is evaluated under volume conditions that approach 100 vehicles per movement during a 15-minute period, the results approach accuracy levels greater than 90%. Since the algorithm relies on data from a vehicle detection system, the performance can degrade (as was found in the supplemental data collection sites) when the line of sight between vehicles and the detection system is interrupted (vehicle not visible). The transfer to practice can be achieved through improvements to the algorithm and by creating a market-ready solution. Turning movement data will have the most direct effect on signal retiming while enabling diverse applications in transportation operations, planning, and safety domains. (NTIS Report Number: PB2017-102163)

DEVELOPMENT OF RENEWABLE POLYMERS FOR USE IN ASPHALT PAVEMENTS

NCHRP-IDEA Project 178

R. Christopher Williams [Tel.: (515) 294-4419, Fax: (515) 294-8216,
Email: rwilliam@iastate.edu]
Iowa State University, Ames, Iowa

This project was aimed at developing and demonstrating the application of biorenewable polymers synthesized from soybean oil for use in asphalt pavements (Figure 1, left). Triglyceride molecules from vegetable oils have been considered as important renewable resources that can be used as biomonomers and be polymerized into biopolymers with properties similar to petroleum-derived monomers and polymers. Biopolymers with various polymer formulations were synthesized to investigate their effects in asphalt modification. Chemical characterization of biopolymers and rheological testing of biopolymer modified asphalt binders were conducted to better understand the materials properties. The results of the evaluations were subsequently used for statistical analysis and modeling to identify the significant polymer formulation parameters that affected the modification results, allowing researchers to optimize the biopolymer formulation for use in asphalt binders. The best-performing biopolymer formulation was produced in the laboratory, and the grading results confirmed its effectiveness in asphalt modification.

A cost comparison between the biopolymer and the styrene-butadiene (SB) based polymer was made to evaluate the economic benefits of biopolymer in the polymer production and the hot mix asphalt (HMA). The comparison indicated that the biopolymer could save about \$2,800 per lane mile in the HMA than the SB polymer. A newly constructed biopolymer pilot plant in Iowa was able to produce more than 600 gallons of the biopolymer for paving a National Center for Asphalt Technology (NCAT) Test Track section (Figure 1, right). Production of the biopolymer at the pilot plant demonstrated the biopolymer polymerization reaction could be scaled up from the laboratory to the pilot plant level. The success of the biopolymer asphalt mixture paving construction proved that the biopolymer could be blended at existing asphalt blending and production facilities, and the mixture could be mixed and compacted as easily as other commercial polymer modified binders in mixtures, working at the same dosage level and delivering similar or even better modification effects. These biopolymers are sustainable, cost-effective, and environmentally friendly. The overall research effort demonstrated the feasibility of implementing the biopolymer into construction practices. The final report is available from the National Technical Information Service (NTIS # PB2019-101386).



Figure 1

Biorenewable polymer (left) and construction of biopolymer NCAT Test Track (right).

DEVELOPMENT OF A PORTABLE TOTAL-STRESS MEASUREMENT INSTRUMENT

NCHRP-IDEA Project 179

Glenn A. Washer [Tel.: (573) 884-0320, Fax: (573) 882-1365, Email: washerg@missouri.edu]
University of Missouri, Columbia, Missouri

This project developed a portable field instrument for in situ measurement of total stress (both dead and live loads) in steel bridge members (Figure 1). Currently, no other tool can perform a total stress measurement on a highway bridge. The developed instrument utilizes the acoustoelastic effect in steel to measure stresses based on ultrasonic wave velocity. The developed technology could be used for safety assessments of bridges by detecting overloaded members, such as gusset plates, at risk of failure. Initial work focused on laboratory testing and development of the ultrasonic technology. This testing included assessment of ultrasonic properties of different types of steel and development of system components. These components were integrated into a self-contained, portable, battery-powered instrument suitable for field operation on a typical highway bridge. Components of commercial instruments were modified to provide unique performance characteristics necessary to support the stress measurement technology, including integrated position encoders necessary to enable automated acoustoelastic measurements. Specific software for processing the ultrasonic signals and providing total stress measurements was developed. Field verification of the new technology (which consisted of making key measurements on a truss bridge to demonstrate the instrument's capability to assess shear stresses in gusset plates and testing the system under real-world conditions) was performed. The test successfully demonstrated the system's capability to determine shear stresses in gusset plates nondestructively. Measurements were verified using destructive methods that confirmed the accuracy of the ultrasonic stress measurements. The instrument, now commercially available, could be used in a variety of applications for highway bridges, including the assessment of gusset plates, primary load bearing members, jointless bridges, pin-and-hanger connections, and force distribution in trusses. (Final Report NTIS Number: PB2018-101352)

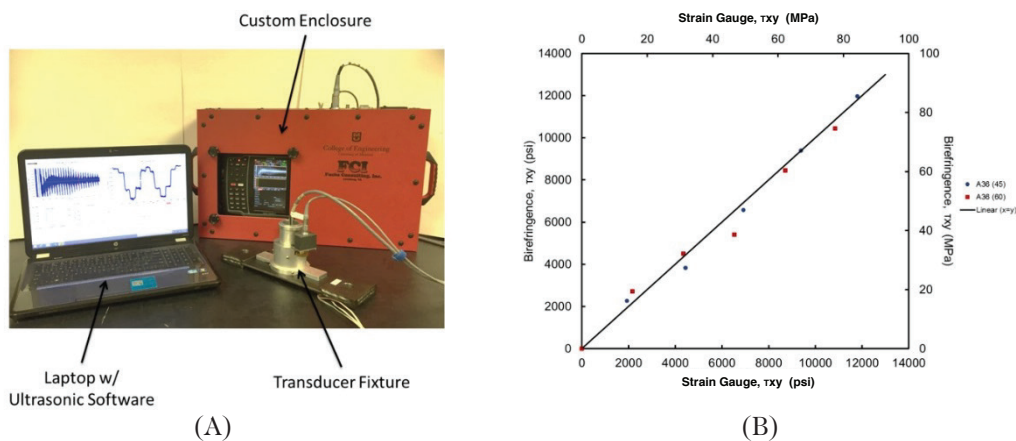

Figure 1

Photograph of the developed technique (A) and results showing the correlation between total stress measured by developed technique and actual stresses measured in a field test (B).

DRAINED TIMBER PILE GROUND IMPROVEMENT FOR LIQUEFACTION MITIGATION

NCHRP-IDEA Project 180

Armin Stuedlein [Tel.: (541) 224-2242, Fax: (541) 737-311,
Email: armin.stuedlein@oregonstate.edu]
Oregon State University, Corvallis, Oregon

This project explored the use of drained driven timber piling to provide a cost-effective liquefaction mitigation strategy for transportation infrastructure. A drained timber pile prototype was developed. Following installation, cone penetration tests showed an increase in relative density associated with different pile spacing and with prefabricated vertical drainage elements. Other in situ tests, including standard penetration and shear wave velocity tests, indicated that the drained piles produced better densification than the conventional piles when spaced at three pile diameters, but had no advantage at less dense spacing. A controlled blasting program was conducted to check the effectiveness of various timber pile configurations to reduce excess pore pressures and ground settlements. Following dissipation of excess pore pressures, the control zone settled 200 mm, while soil in between the piles settled approximately 20 to 80 mm, and piles that were tipped within a dense layer settled approximately 20 mm, on average. All excess pore pressures in the improved ground were lower than those in the unimproved ground and showed dilatationary responses at the end of the blasting cycle. Simulation of blasting for drained piles indicated that drains with a larger discharge capacity would be required to help reduce excess pore pressures during strong ground motion. The methodology is available to implementation by state DOTs. (NTIS Report Number: PB2017-1021610)



Figure 1

Drained timber piles for soil liquefaction mitigation hazard.

DEVELOPMENT OF SMALL SPECIMEN GEOMETRY FOR ASPHALT MIXTURE PERFORMANCE TESTING

NCHRP-IDEA Project 181

Cassie Castorena [Tel.: (919) 515-6411, Email: cahintz@ncsu.edu]

North Carolina State University, Raleigh, North Carolina

This project was aimed at developing small specimen geometry for uniaxial dynamic modulus and fatigue testing in the asphalt mixture performance tester (AMPT). A set-up for small specimen testing in the AMPT was developed, and the effect of specimen geometry for mixtures with varying nominal minimal aggregate size (NMAS) was evaluated to determine whether or not the representative volume element (RVE) requirement is satisfied for dynamic modulus and fatigue testing. Plant-produced loose mixes of five different types with varying NMAS values, (ranging from 9.5 mm to 25 mm) were procured. Dynamic modulus results indicate good agreement between the results of small and large specimens for test temperatures at or below 40°C (Figure 1). Cyclic direct tension fatigue test results indicate good agreement between large and small specimens. To develop a uniform procedure for laboratory specimen fabrication, the effect of coring direction was evaluated. Anisotropy did not have an impact on performance test results. Horizontal extraction of specimens appeared problematic for fatigue testing, and so vertical coring was selected as the optimal method for laboratory sample fabrication and used for specimen-to-specimen variability of four plant-produced mixtures with varying NMAS (up to 25 mm). Small specimen performance test results generally demonstrated an increase in specimen-to-specimen variability with increasing NMAS, which also was observed in large specimen testing. Draft AASHTO specifications for specimen preparation, AMPT dynamic modulus testing, and AMPT cyclic fatigue testing of the asphalt concrete were developed for consideration by the AASHTO's materials subcommittee. Development of small specimen ancillary devices and testing platens has commenced with IPC Global. (Final Report NTIS Number: PB2018-101353)

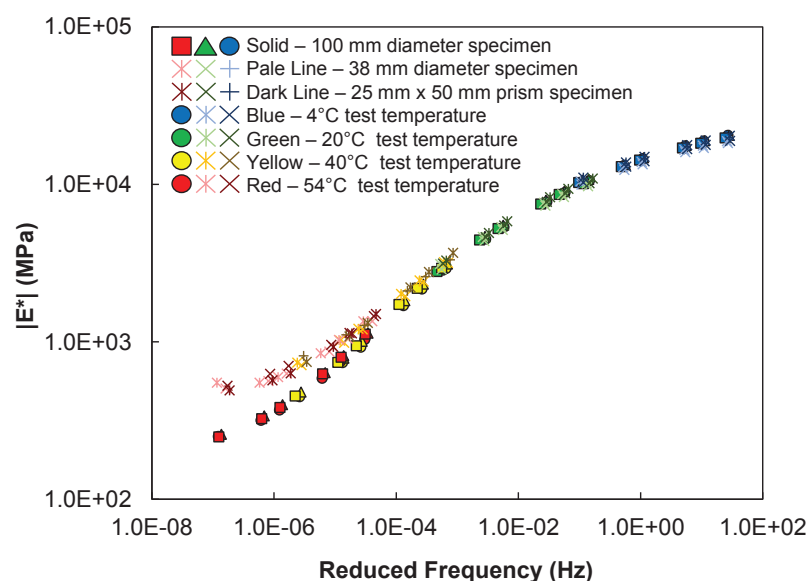

Figure 1

Comparison of dynamic modulus master curves of small and full size specimens.

REDUCING STORMWATER RUNOFF AND POLLUTANT LOADING WITH BIOCHAR ADDITION TO HIGHWAY GREENWAYS

NCHRP-IDEA Project 182

Paul T. Imhoff [Tel.: (302) 831-0541, Fax: (302) 831-3640, Email: imhoff@udel.edu]
University of Delaware, Newark, Delaware

The purpose of this study was to reduce nutrient loading and stormwater runoff volume by adding biochar to the soils of highway greenways. The effect of biochar amendment on the hydrologic properties of three natural soils typically found along highway greenways in the mid-Atlantic region was quantified with 2% and 6% biochar. With biochar addition, water holding capacity and unsaturated hydraulic conductivity of the natural soils increased 5-46% and 50-300%, respectively, while saturated hydraulic conductivity decreased 6-61%. Pilot-scale experiments were designed (Figure 1) to evaluate the impact of biochar-amended greenways on stormwater runoff in which a 24 h storm event with the scaled intensity equal to 10 mm/h was applied to a silt loam with 6% biochar. Biochar amendment reduced runoff by 18%, thus, 18% of the pollutant load to nearby water bodies was eliminated. In addition, saturated water content of the soil increased by 15% in biochar-amended soils, which should enhance denitrification for stormwater that infiltrates the soil. At a field site where biochar was amended to the top 30 cm of a roadway soil, a 4% by mass biochar amendment reduced runoff volume by 83% over 50 storm events, resulting in ~ 83% reduction in loading of nutrients and sediments. The cost of biochar-amended roadway soils for treating stormwater appears comparable to that for urban grass buffers, but requiring much less land: 0.12 acre of biochar versus 3.7 acre of urban grass buffer to treat 1-acre impervious roadway. The researchers are working with Delaware and Maryland DOTs to scale-up and implement the biochar amendment of soils. (Final Report NTIS Number: PB2018-101354)

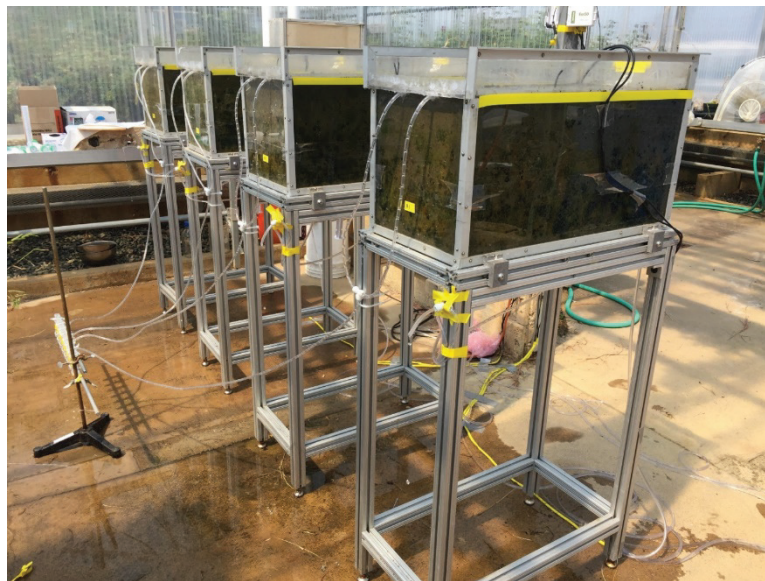

Figure 1

Plot-scale experimental cells.

A RADIO FREQUENCY IDENTIFICATION (RFID) DETECTION SYSTEM FOR ASSESSING SCOUR COUNTERMEASURES AND THE STABILITY OF HYDRAULIC STRUCTURES

NCHRP-IDEA Project 183

Thanos Papanicolaou [Tel.: (865) 974-7836, Fax: (865) 974-2699, Email: tpapanic@utk.edu]
University of Tennessee, Knoxville, Tennessee.

This project was aimed at developing a novel Radio Frequency Identification (RFID) Scour Detection System, known as the RSDS, for monitoring scour hole evolution autonomously, continuously, and remotely near bridge piers and abutments, providing repeatable and reliable 3-D scour data for both clear-water and live-bed scour conditions. Figure 1 is a conceptual illustration of the process for estimating the scour hole geometry around hydraulic structures using the Return Signal Strength Indication (RSSI) of RFID sensors (transponders) buried in their vicinity. To improve the applicability of the RFID technology for measuring scour, an existing RFID system was enhanced and evaluated in the laboratory and the field. The enhancements included (1) integrated circuits and inclinometers added to improve accuracy and detectability when buried; (2) the implementation of a “wake-up” function to selectively activate a unique transponder; (3) triangulation functionality to identify the x , y , and z coordinates; (4) use of potting compound to prevent moisture build-up; and (5) enabling remote interaction with network capabilities. It was shown that the continuous, real-time measurements of the RSDS can capture the modification to bed shear stress as the scour hole evolves and the resultant effect on the growth rate and extent of the scour hole. This resulting formulation is a decay function, in which the shear force applied by the flow decays as the scour hole develops. The RSDS automates scour data collection and transmission, eliminating the need for onsite surveys and ensuring personnel safety. The RSDS also improves manager insight and decision-making by facilitating a shift to condition-based management that offers a cost reduction through timely recognition. The final report is available from the National Technical Information Service (NTIS # PB2019-101387).

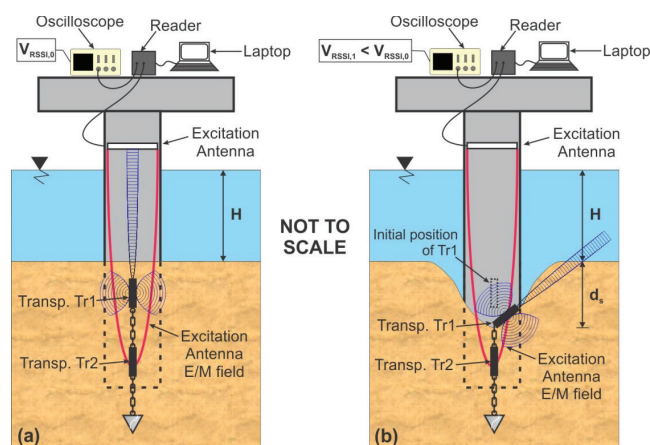

Figure 1

Conceptual illustration of the process for estimating the scour hole geometry around hydraulic structures using the Return Signal Strength Indication of Radio Frequency Identification sensors (transponders) buried in their vicinity: (a) no scour and (b) scour condition. E/M = electromagnetic.

SYNTHETIC HOUSEHOLD TRAVEL DATA USING CONSUMER AND MOBILE PHONE DATA

NCHRP-IDEA Project 184

Josephine Kressner, [Tel.: (630) 426-9076, Email: josie@transportfoundry.com]
 Transport Foundry, Atlanta, Georgia

The aim of this IDEA project was to apply a prototype in Seattle, Atlanta, and Asheville that fuses passive, big data—including household-level data, firm-level data, and location and speed data from mobile phones—into individual-level synthetic travel diaries. Synthetic travel diaries reveal where, when, why, and how individual people travel, with each person's demographic data appended (e.g. household income, age). The project focused on making the prototype consistent nationally, rapidly deployable for any size city, and systematically updatable over regular time periods. The prototype uses a simulation framework to fuse the passive data with National Household Travel Survey data. The method produces locally sensitive synthetic populations with individual-level travel diaries using the same code in the three metropolitan regions investigated. The validations of time use, tours per day, and geographic distribution of trips were comparable to other validation datasets in each region, and the differences discovered in these measures appear to be reasonable considering the variability in the regional travel estimates. As results for Asheville, North Carolina (Figure 1) show, the passive data model produced effectively equivalent levels of accuracy when compared with the aggregate trip-based model using standard validation measures of the assignment results. These results suggest that this passive data approach to analysis will allow engineers and planners to investigate travel behavior in a way that is not feasible today, including improvements to travel demand modeling, tolling studies, before-and-after studies, and congestion mitigation studies. (Final Report NTIS # PB2018-100053)



Figure 1

Validation results in Asheville, North Carolina, after static assignment.

CURVEPORTAL FOR AUTOMATED IDENTIFICATION AND EXTRACTION OF HORIZONTAL CURVE INFORMATION

NCHRP-IDEA Project 185

David A. Noyce [Tel.: (608) 265-1882; Fax: (608) 262-5199; Email: noyce@engr.wisc.edu]

Madhav Chitturi [Email: mchitturi@wisc.edu]

Andrea R. Bill [Email: bill@wisc.edu]

University of Wisconsin, Madison, Wisconsin

This project developed a prototype of CurvePortal, a web interface for automatically extracting horizontal curve location and geometric information from GIS roadway maps using an improved curve data extraction algorithm (CurveFinder). The concept of the algorithm is to use the directional offsets of successive line vertices to identify and categorize roadway curves as shown in Figure 1. Model Inventory of Roadway Elements (MIRE) curve types and MIRE horizontal curve elements, including curve length, radius, degree of curvature, direction, etc. (except for superelevation) were incorporated and their compatibility validated. The CurveFinder algorithm was improved, especially its accuracy when applied on low-quality GIS roadway maps. Additional automation features were incorporated to enhance CurveFinder's efficiency and accuracy. A prototype CurvePortal was developed that transportation agencies could access to upload their GIS roadway shapefiles for curve data extraction. The CurvePortal is hosted on WisTransPortal, an online transportation data portal at the University of Wisconsin–Madison. Technology transfer efforts have been initiated with several state DOTs that have expressed interest in using CurveFinder/CurvePortal. (Final Report NTIS Number: PB2018-101355)

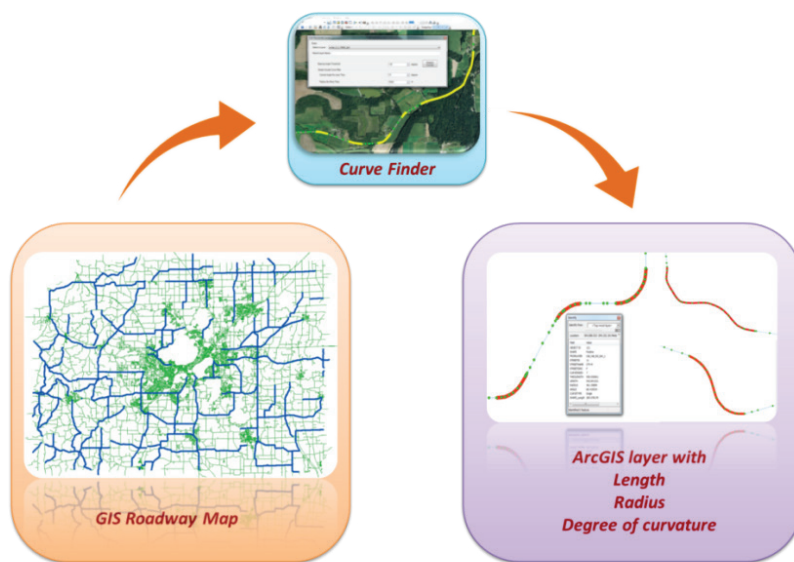

Figure 1

Concept of CurveFinder.

DEVELOPMENT OF AN ELECTRICAL RESISTIVITY PUSH PROBE FOR RAPID ASSESSMENT OF GROUND IMPROVEMENT

NCHRP-IDEA Project 186

Mike Mooney [Tel.: (303) 384-2498, Fax: (303) 273-3602, Email: mooney@mines.edu]
Colorado School of Mines, Golden, Colorado

This project developed an electrical push probe and its deployment system (Figure 1) to measure the geometry of ground improvement columns (jet grout, soil mixed, auger cast) during construction or immediately after construction (within 30-60 minutes). The probe exploits the significant resistivity contrast between fresh soilcrete and in situ soil to image the boundary between the column and soil. The probe was designed using finite element modeling via COMSOL Multiphysics to inform the necessary electrode spacing and injection/measurement protocols to successfully image the constructible range of soilcrete column diameters in a variety of soil conditions. The probe was engineered to be easily deployable and field-ruggedized and was constructed of ultra-high molecular weight polyethylene, which had a high density to overcome the buoyancy effect in soilcrete columns and is resistant to impact and abrasion. The probe is inserted into a freshly jet grouted column immediately after removing the jet grout monitor. The test requires 20-30 minutes to collect sufficient data to estimate column diameter. The probe was implemented on multiple jet grout construction project sites, primarily granular soil sites (sands, silty sands). In all cases, the estimated diameter was found to be within 5% of the actual constructed diameter. The push probe provides a non-destructive assessment of production columns and results in significant time savings. Instead of waiting 7 days after jet grouting to perform coring and another 7-21 days for unconfined compressive strength test results, a contractor can assess the diameter within 30 minutes of jet grouting. This provides immediate actionable feedback as the contractor can modify jet grouting parameters as needed within the same work shift. Further, the ability to verify diameter immediately and move on to production can save significant time and money.

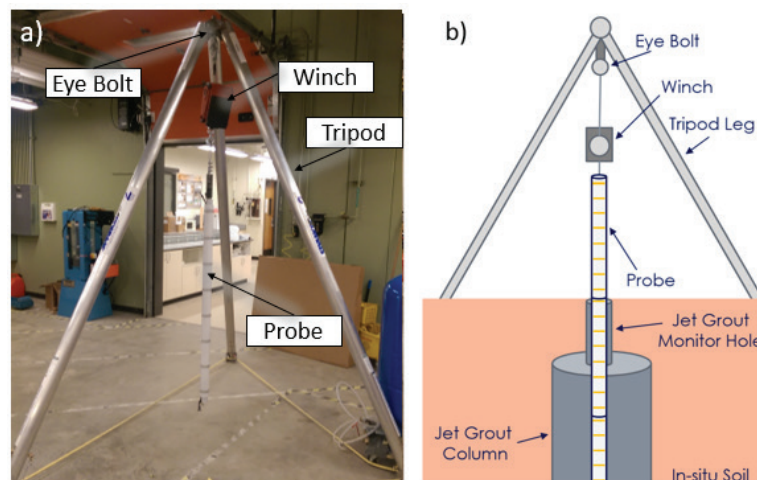

Figure 1

(a) Photo of the tripod deployment system and one probe section assembled in the lab, and
(b) illustration of the probe and tripod deployment system placed in a jet grout column.

A LOW-COST MOBILE PROXIMITY WARNING SYSTEM IN HIGHWAY WORK ZONES

NCHRP-IDEA Project 187

Yong Kwon Cho [Tel.: (404) 385-2038; Email: yong.cho@ce.gatech.edu]
Georgia Institute of Technology, Atlanta, Georgia

IDEA Concept and Product

This project was aimed at developing and validating a low-cost wireless worker proximity detection and alert sensing system for proactive safety warning in dynamic roadway work zones (Figure 1). A Bluetooth proximity sensing system was developed with customized software. Through Bluetooth-enabled smart devices, such as smartphones and smartwatches, audio and vibratory alerts are sent simultaneously to pedestrian workers and equipment operators when they are in hazardous proximity situations. Extensive lab tests and field trials under controlled environments were conducted to develop and improve the functionalities of the proximity sensing and alert system, and field tests were conducted at an earthmoving construction job site to evaluate the practicality of the system. The primary research findings include: (1) the Bluetooth proximity alert system provides reliable alerts during hazardous proximity situations, based on test results and feedback from workers who participated in the field tests; (2) the experimental results in controlled environments demonstrate that the Bluetooth proximity sensing and alert system provides reliable results with an appropriate alarm, with slight performance differences when equipment approaches a worker at various speeds; (3) the adaptive signal processing algorithm developed in this research was able to significantly reduce the signal processing delay and inconsistency of the Bluetooth system caused by vehicle's approaching speeds; and (4) the field test results show that frequencies of hazardous proximity situations highly depend on the type of equipment and type of work to be performed nearby. The overall study demonstrated that the Bluetooth proximity alert system has a high potential to enhance safety in roadway construction due to its high accuracy, low cost, easy-to-use, scalability, and smart functions. Georgia DOT is evaluating the system for implementation. (Final Report NTIS Number: PB2018-101356)

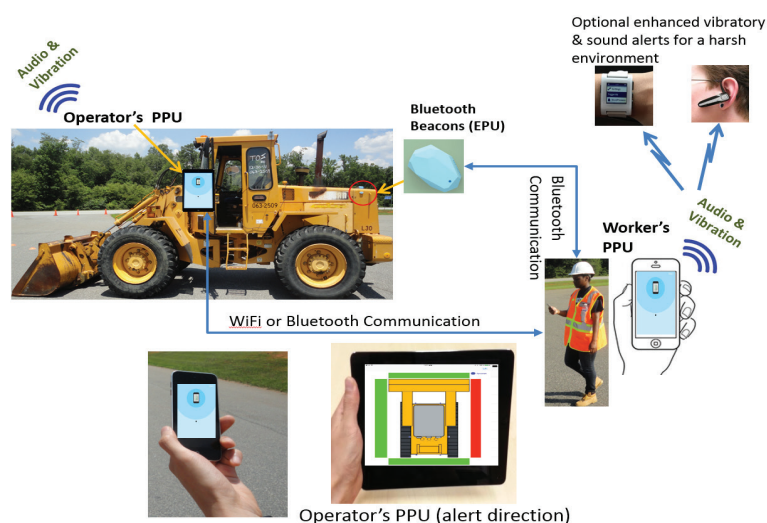

Figure 1

Concept of a mobile proximity safety warning system.

A CLASS OF V-CONNECTORS FOR BRIDGE DECK PIER AND PIER-FOOTING JOINTS ALLOWING INTEGRATED DESIGN AND SEISMIC ISOLATION WHILE ENABLING ACCELERATED BRIDGE CONSTRUCTION

NCHRP-IDEA Project 188

Su Hao [Tel.: (949) 679-9047; Fax: (855) 207-9835; Email: hao@suhao-acii.com]

ACII, Inc., Irvine, California/Wilmette, Illinois

This project developed a class of innovative V-connectors for use as joints between bridge pier and superstructure or between pier and footing, facilitating accelerated bridge construction and providing robustness for needed seismic resistance (Figure 1). Two design subgroups, fixed-end pin (FP) and hinge-end pin (HP), were further developed (Figure 2). In both designs, the top part of the connector was directly mounted onto the bottom surface of a bridge, which is similar to a conventional bearing pod. Two groups of specimens with the HP design were fabricated and tested at the Pacific Earthquake Engineering Research Center at the University of California–Berkeley and a bridge laboratory in China with a 2-degree hybrid-like test. The test involved analytical modeling of the superstructure behavior and experimental testing of the substructure with the V-connectors. The tests demonstrated that the V-connectors do present the hysteresis behavior for seismic isolation, as predicted in Figure 1, providing the expected seismic resistance performance for bridge engineering applications. The final report is available from the National Technical Information Service (NTIS # PB2019-101388).

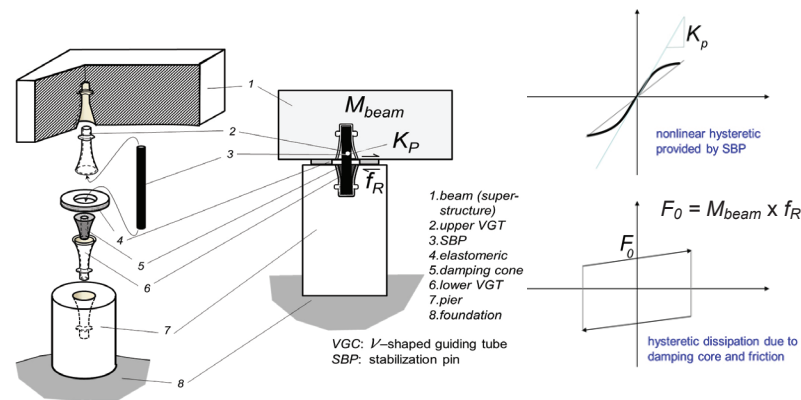

Figure 1

Concept of the V-connectors.

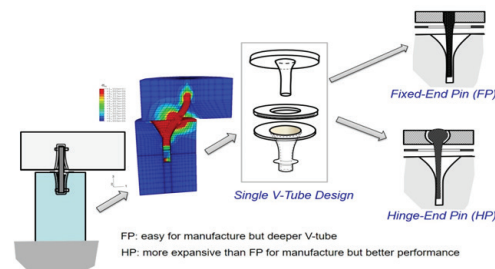

Figure 2

Two subgroup designs of the V-connectors' products family.

A NOVEL VISION SENSOR FOR REMOTE MEASUREMENT OF BRIDGE DISPLACEMENT

NCHRP-IDEA Project 189

Maria Q. Feng [Tel.: (212) 854-1182, Fax: (212) 854-6267, Email: mfeng@columbia.edu]
Columbia University, New York City, New York

This project developed a camera-based computer vision sensor system for accurate remote measurement of multi-point bridge displacements in outdoor environments that significantly reduces the cost of the equipment and operation as compared with conventional sensors. Figure 1 depicts the system, consisting of a camera and a tablet PC, for multi-point accurate measurement of bridge displacements, by cancelling camera vibration using a stationary point as a reference. To overcome issues with outdoor conditions such as changes in illumination and background, heat haze-induced image distortions, and camera vibration that can cause significant measurement errors, innovative algorithms for robust tracking of “natural markers,” heat haze filtering techniques, and vibration cancellation methods were developed. In addition, this project proposed a practical calibration method to convert image pixel displacements into physical displacements. The developed algorithms were integrated into a software package, and field performance evaluation tests were carried out in three bridges, including two long-span steel bridges—the Manhattan Bridge and the Williamsburg Bridge—and a short-span concrete bridge, the Jamboree Bridge. The remote, real-time, and multi-point measurement capabilities of the developed vision sensor system were further validated in the presence of various sources of field environmental noise, including heat haze and camera vibration. In the future, the system can be further developed for permanent installation at bridge sites to enable long-term continuous monitoring of structural integrity and safety. The final report is available from the National Technical Information Service (NTIS # PB2019-101389).

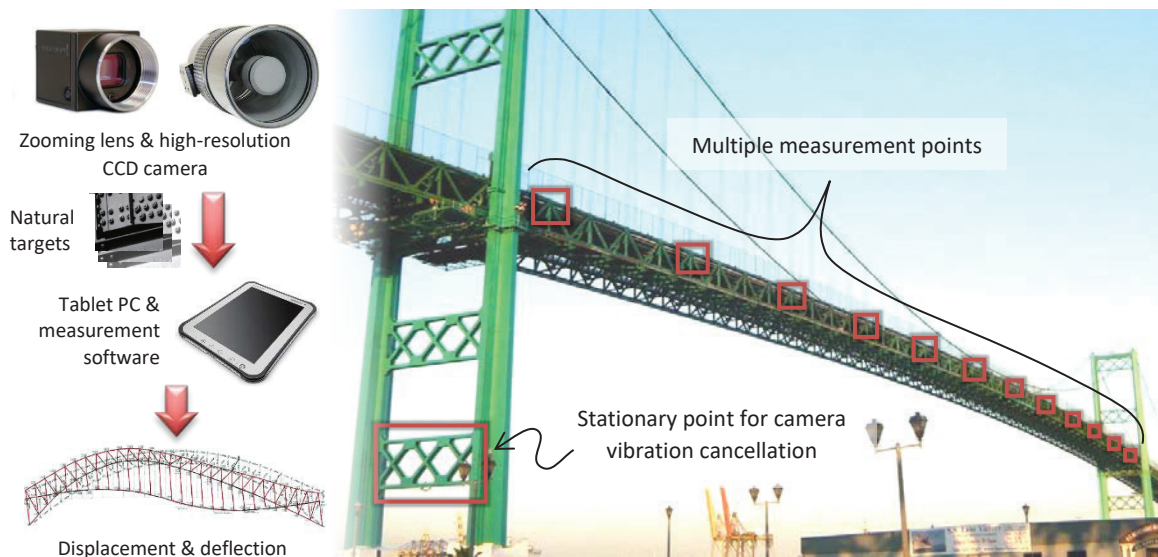

Figure 1

Vision sensors for remote multi-point measurement of bridge displacements.

TESTING OF IN-SERVICE BRIDGES USING AUTOMATED ULTRASONIC TESTING METHODS

NCHRP-IDEA Project 191

Shane Boone [Tel.: (919) 999-3779 x108, Email: shaneb@bditest.com]
Bridge Diagnostics, Inc., Raleigh, North Carolina

The project was aimed at developing methods, equipment, and software for advanced automation of ultrasonic testing of bridge members. Current bridge inspection practice is to use conventional testing methods like ultrasonic (UT) and radiographic (RT) test methods that tend to provide low overall resolution evaluations of a bridge's condition. To increase this resolution in a cost-effective manner and at the same time improve the accuracy and reliability of the measurements, this study investigated the effectiveness of automated ultrasonic testing (AUT). A prototype test system was developed using a low-cost (\$500) X-Y plotter as its basis, leveraging its capacity for precise, programmable movement of an integrated Phased Array Ultrasonic Testing (PAUT) probe (Figure 1). The AUT prototype was tested on laboratory specimens with manufactured weld flaws and in the field, with the resulting output of the system being compared with the output gathered by the American Society for Nondestructive Testing (ASNT) Level III UT inspectors. Based on this comparison, the AUT prototype was found to produce data of quality equal to that of the manual inspectors while executing an automated routine for gathering such data. In reviewing the use of PAUT, both the manual and automated inspections demonstrated the importance of grinding welds flush to the joint to minimize noise. Despite the similarity of results between the AUT system and manual inspectors, the challenges of mounting and deploying such a system on bridges of unknown or variable configurations were not resolved, making the system more relevant to production-welding environments, where the automation aspect could be more appropriately utilized.

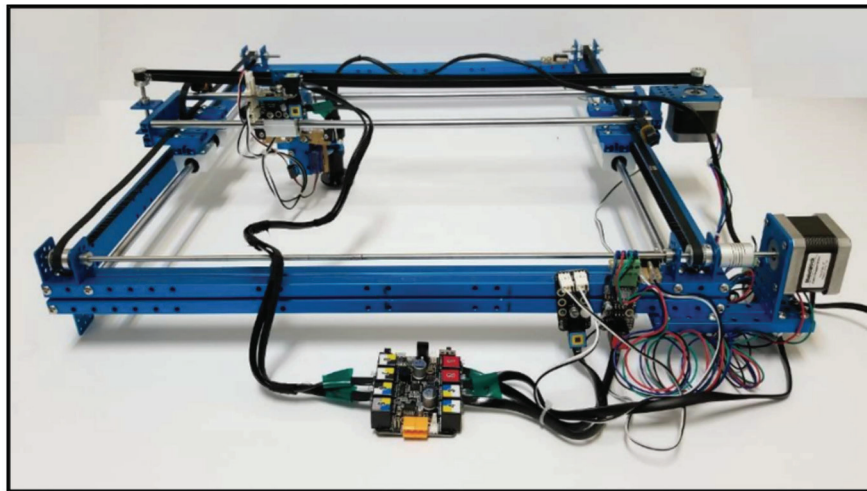

Figure 1

Prototype AUT System (based on Makeblock XY Plotter Robot Kit).

APPLICATION OF MICROBIAL FACILITATED STABILIZATION FOR SUSTAINABLE IMPROVEMENT OF EXPANSIVE PAVEMENT SUBGRADES

NCHRP-IDEA Project 192

Bhaskar Chittoori [Tel.: (208) 426-3794, Fax: (208) 426-2351,
Email: bhaskarchittoori@boisestate.edu]
Boise State University, Boise, Idaho

This project explored the application of microbial induced calcite precipitation (MICP) through bio-stimulation to stabilize problematic expansive soils. Expansive soils cause significant damage to the highway infrastructure because of their ability to undergo significant volume changes with water content fluctuations. Various ground improvement techniques like chemical stabilization, deep soil mixing, and moisture barriers are employed to counteract the problems caused by these soils; however, these methods are either expensive or have an adverse impact on the environment. A more sustainable and economic alternative is the microbiological treatment of soils. MICP is an innovative process that could be used to improve the engineering properties of soil through calcite precipitation using urease-producing bacteria. The MICP process to stabilize expansive soils was investigated through laboratory and field work (Figure 1). The laboratory work investigated the role of soil type, clay content, and bacterial populations on treatment effectiveness and developed a protocol for field implementation. Laboratory results established the feasibility of calcite precipitation in natural soils using native soil bacteria and modifying the behavior of the soils. The impact of calcite precipitation on strength improvement and swell reduction was significant. Field test results showed that calcite precipitation increased with bacteria-containing solution treatments (up to 8% total), and the free swell index dropped from 114% to 29%. It was concluded that MICP could be successfully replicated in the field through successive injections of enrichment and cementation solutions into the soil. Additional field tests are necessary for improving the system and realizing the full benefits of the MICP.



Figure 1

MICP treatment of soils in the laboratory (left) and in the field (right).

DART FIELD VALIDATION AND PROTOTYPE REFINEMENT

NCHRP-IDEA Project 193

Chetana Rao [Tel.: (217) 369-6865, Email: crao@raorc.com]

Rao Research and Consulting, LLC, Champaign, Illinois

This project evaluated the Duomorph Asphalt Rheology Tester (DART) technology, a low-cost, piezoelectric sensor-based portable testing system, to monitor the consistency and uniformity of asphalt binders in real-world production environment beyond controlled research grade settings. Physical improvements were made to the instrument for field portability and software improvements to enhance automation and reduce user controls. Significant improvements also were made to the standard protocols and additional features included in the device (specifically the introduction of a potentiometer in the circuit to enable balancing the bridge for each sensor) to reduce system noise. A large set of asphalt binders was tested in the laboratory. In general, the DART device was capable of matching “like” materials [i.e., of same performance grade (PG)] and distinguishing samples of different grades using materials from three different suppliers and a variety of PGs. Next in tests on binders from two states, DART could identify based on fingerprint comparisons of samples that satisfied the AASHTO M 320 specifications. Further, tests on samples from an asphalt binder production facility showed that the trends in viscosity were evident, and there is potential to use DART in a binder optimization process. Based on this study’s results, the DART device could be an effective tool for process control of asphalt binders to enable larger sampling rates and faster testing of asphalt binders in production facilities or district laboratories. Testing can be completed in as few as 2.5 hours with minimal operator time or skills. In its current stage of development, DART can supplement, although not replace, AASHTO M 320 PG specification testing. It provides a means to verify binder consistency or to check deviation of a field sample from a certified sample. (Final Report NTIS Number: PB2018-101357)

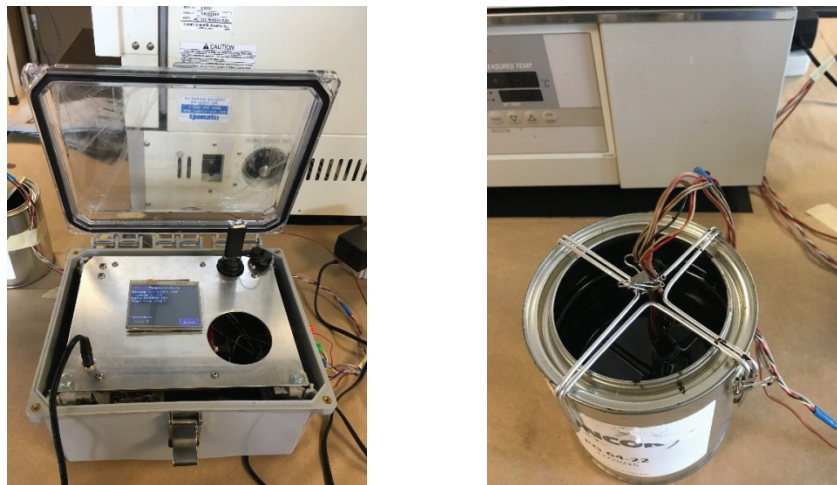

Figure 1

DART prototype for field testing and binder testing setup.

DEVELOPMENT OF AN IDEAL CRACKING TEST FOR ASPHALT MIX DESIGN, QUALITY CONTROL, AND QUALITY ASSURANCE

NCHRP-IDEA Project 195

Fujie Zhou [Tel: (979) 458-3965, Fax: (979) 845-1701, Email: f-zhou@tti.tamu.edu]
Texas A&M Transportation Institute, College Station, Texas

This project developed a simple, performance-based indirect tensile asphalt cracking test (IDEAL-CT) (Figure 1) for asphalt mix design, quality control, and quality assurance. The test offers (1) simplicity (no instrumentation, cutting, gluing, drilling, or notching); (2) efficiency (test completion within 1 min.); (3) practicality (minimum training for operator and suitable for both laboratory molded specimens and field cores); (4) low-cost test equipment; (5) repeatability (low variability); (6) sensitivity (sensitive to asphalt mix compositions and aging); and (7) good correlation with field cracking performance. The test is now an ASTM standard test method (ASTM D8225-19: Standard Test Method for Determination of Cracking Tolerance Index of Asphalt Mixture Using the Indirect Tensile Cracking Test at Intermediate Temperature). Two equipment manufacturers, InstronTek and Testquip, have standalone machines to perform the IDEAL-CT. InstronTek also has an IDEAL-CT fixture fitting for existing machines or loading frames. A video describing the test method is available on YouTube (<https://www.youtube.com/watch?v=OB4pQDB2Yfs>). An article describing the IDEAL-CT was published in the trade magazine, *Roads and Bridges* (<https://www.roadsbridges.com/ideal-candidate>). The test has been evaluated by a number of state DOTs, including Georgia, Kentucky, Minnesota, Maine, Missouri, Ohio, Oklahoma, Virginia, and Texas. Virginia and Texas have already adopted the test. The NCHRP has initiated an implementation project to facilitate implementation of the test by state DOTs. The final report is available from the National Technical Information Service (NTIS # PB2019-101392).



Figure 1

IDEAL-CT test setup.

HEXAGONAL BORON NITRIDE REINFORCED MULTIFUNCTIONAL CONCRETE FOR TRANSPORTATION INFRASTRUCTURE

NCHRP-IDEA Project 197

Rouzbah Shamsavari [Tel.: (617) 872-6507, Email: Rouzbah@ccretetech.com]
C-Crete Technologies, LLC, Houston, Texas

This project developed a new class of ultra-high performance, multifunctional concrete using emerging two-dimensional (2-D) materials. The core strategy involved mixing ultra-thin exfoliated nanosheets of 2-D materials such as hexagonal Boron Nitride (hBN) as small as a few atoms in thickness in the bulk concrete (Figure 1). This hBN exhibits several remarkable properties (ultra-high mechanical and thermal properties, chemical inertness, hydrophobicity, etc.) that are highly desirable for a complex matrix such as concrete. These features, combined with the double surface area per mass of hBN sheets, as compared with conventional one-dimensional (1-D) fibers, can act as template (seeds) to regulate the hydration processes and maximize contact between the sheets and the matrix, thereby providing an effective reinforcement from the bottom up. Several different routes were pursued to investigate the degree of exfoliation and reduction in the size of hBN (to increase surface area), as well as their functionality and water solubility in effectively mixing them in concrete. Concrete coupons were synthesized with various weight percentages of 2-D materials. The compressive strength of concrete cylinders was found to increase by >71%, and the tensile strength by >100%, with only a very small addition of the 2-D materials. The measured durability properties of the concrete samples also showed an increase of about 35%, compared with the control sample without hBN. For implementation and field evaluation, after discussions with Texas DOT, a patch/repair job on a road/highway was determined to be a good starting point. To meet the DOT's requirement, the compatibility of the hBN concrete formulation was examined with common accelerators such as CaCl_2 . No negative cross-effects between the new concrete and the common accelerators were found. The concrete achieved a compressive strength of 1,800 psi in only about 5 hours, making the technology suitable for rapid construction and/or maintenance in transportation applications.

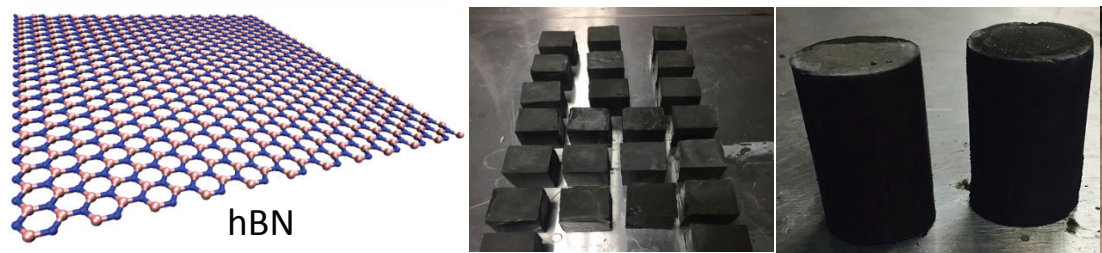

Figure 1

Multifunctional hBN/concrete: an atomistic image of a monolayer of hBN (left); representative coupons of hBN/cement mortar (center); and representative coupons of hBN/concrete (right).

PROTOTYPE DEVELOPMENT FOR OBTAINING AUTOMATED TURNING MOVEMENT COUNTS FOR SHARED LANES

NCHRP-IDEA Project 198

David A. Noyce [Tel.: (608) 265-1882, Fax: (608) 262-5199, Email: danoyce@wisc.edu]

Madhav Chitturi [Email: mchitturi@wisc.edu]; Andrea R. Bill [Email: bill@wisc.edu];

Kelvin R. Santiago-Chaparro [Email: ksantiago@wisc.edu]

University of Wisconsin–Madison, Madison, Wisconsin

This project improved a vehicle trajectory classification algorithm developed in an earlier IDEA project (NCHRP-IDEA Project 177) to demonstrate the feasibility of automatically classifying vehicle trajectories into movements regardless of the lane configuration. Specifically, the improvements focused on two areas: first, improving the vehicle count by more reliably recognizing the vehicles that crossed the stop bar of an approach and, second, by using the lane used by the vehicles and lateral displacement to assign a movement to vehicle trajectories. A data collection device was developed that was capable of logging vehicle trajectories from intersections instrumented with a commercially available radar-based vehicle detection system. The data collection device is independent of the controller platform and can be installed inside a signal cabinet. An initial version of the device was released by the commercialization partner. The device implements key noise removal techniques and can serve as a platform for future performance-monitoring techniques. The device also implements procedures to breakdown vehicle volume at an intersection approach by lane (Figure 1). As a result, adding classification by movement, based on a streamlined version of procedures developed in the earlier IDEA project, can be accomplished via a software update. Once the necessary commercialization steps with the licensing arm of the University of Wisconsin–Madison clear, the commercialization partner plans to integrate a streamlined version of the classification algorithm into its product via a software update.



Figure 1

Evolution of trajectory data set: Original to de-noised to classified by movement.

USING MEDICAL X-RAY MACHINES TO DETERMINE THE SERVICE LIFE OF CONCRETE

NCHRP-IDEA Project 199

Tyler Ley [Tel.: (405) 744-5257, Fax: (405) 744-7554, Email: tyler.ley@okstate.edu]

Qinang Hu [Email: qinang@ostatemail.okstate.edu]

Oklahoma State University, Stillwater, Oklahoma

This project developed an x-ray prototype that uses dental x-ray equipment with the capability to safely measure fluid penetration into cement paste, mortar, and concrete for permeability measurement both in the laboratory and in the field. A sampling method was developed to obtain samples from the field, and a software code was written for data analysis of the imaging process. An x-ray prototype was developed for measuring concrete permeability (Figure 1, *left*). Several modifications and adjustments were made to produce an easy-to-use sample stage. A case study was conducted for the Oklahoma DOT, which showed the value of the equipment for evaluating the permeability of different bridge decks and the efficiency of the silane sealers. The developed x-ray technique is a practical, rapid, safe, and inexpensive approach to x-ray imaging of concrete, mortar, and cementitious paste to measure their permeability (Figure 1, *right*). The method can be used during ongoing construction or on in-place infrastructure. The information from the x-ray imaging device should enable DOTs to determine accurately the quality and expected service life of their concrete infrastructure. In addition to measuring the permeability, the method can also be used to compare the effectiveness of different repair materials or the use of surface sealers to extend the service life of the concrete.



Figure 1

X-ray prototype (left) and X-ray imaging of ions penetrating with time (right).

RAPID REHABILITATION OF HIGHWAY SLOPES USING SEEDED MICROBIAL BIO-CEMENT

NCHRP-IDEA Project 200

Bret Lingwall [Tel.: (605) 394-1683, Email: bret.lingwall@sdsmt.edu]

South Dakota School of Mines and Technology, Rapid City, South Dakota

The project was aimed at developing and field testing a method using native grass and weed-seeded microbial-induced calcite precipitation (MICP) to mitigate wind and water erosion of highway slopes, especially those burned in wildfires. Figure 1 illustrates the MICP concept. Ureolytic bacteria, *Sporosarcina Pasteurii*, were used to induce MICP bio-mineralization. Laboratory tests were performed, in which soil samples of burned soils, soils from construction projects, and native soils from the Black Hills area in South Dakota were collected for a suite of MICP treatment tests under multi-variate controls and subsequent wind and rainfall erosion testing, plus seed germination studies. Field tests were performed at three sites local to Rapid City, South Dakota, which included all multivariate treatments that were tested in the laboratory. Erosion and vegetation rates were monitored in the field under natural conditions. Laboratory tests showed that the most robust crust was developed in clean sands, but an erosion-resistant crust still developed on a range of soil types, including clayey soils, provided the clayey soil was not highly compacted. Field testing showed that the technology would take at least 24 hours to set up before it could resist intense thunderstorms but was viable in most loose soils and after wildfires. The results of the study show that the hybrid seeded-MICP approach is able to rapidly develop an erosion-resistant crust at a myriad of sites and soil conditions after construction, maintenance, or wildfire. At the same time, the approach accelerates revegetation, provided the local native grass and plant seed mixture contains a variety of pH- and salt-tolerant species. The technology reduces wind and rain erosion rates significantly for wind speeds under 40 miles per hour and rainfall intensities of 1-inch per hour or less.

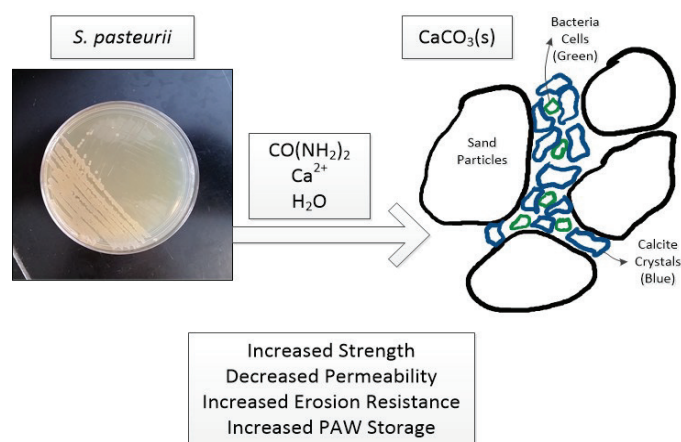

Figure 1

Overview of microbial bio-cementation process using ureolytic bacteria (PAW = plant available water).

DEVELOPMENT OF A NOVEL AERODYNAMIC SOLUTION TO MITIGATE LARGE VIBRATIONS IN TRAFFIC SIGNAL STRUCTURES

NCHRP-IDEA Project 201

Alice Alipour [Tel.: (515) 294-3280, Fax: (515) 294-4560, Email: alipour@iastate.edu]

Partha Sarkar [Tel.: (515) 294-0719, Fax: (515) 294-3262, Email: ppsarkar@iastate.edu]

Iowa State University, Ames, Iowa

Cantilevered traffic signal structures are widely used as supports for traffic signals in the United States. Many instances of the failures of such structures have been reported in the past, which have been attributed to large amplitude vibrations caused by galloping, vortex shedding, natural wind gusts, and truck-induced gusts. The reason for these large amplitude vibrations is low mechanical damping (0.1%-0.4%) in these structures. This project explored “aerodynamic damping” as an active means to mitigate large amplitude vibrations of traffic signal structures. The proposed method is considered superior to other common approaches because it uses the inherent characteristics of the signal light to ensure that the positive aerodynamic damping is maximized during the gust events. Further, it does not require specific tuning (like those required by mechanical damping devices) or implementation of heavier fatigue-rated connections. Wind tunnel tests were conducted on traffic light and mast arm models to extract aerodynamic and aeroelastic coefficients for the base model and the modified models. A traffic signal structure in Ames, Iowa, was selected for long-term monitoring (Figure 1). Field measurements for mast arm vibrations in along-wind and across-wind directions were analyzed to understand critical wind speed, critical wind direction, and major types of wind forces on the structure. An analytical model of the monitored traffic signal structure was generated and validated by comparing the simulated response with field measurements. The comparison of simulated wind-induced responses showed the performance of the modified traffic light to be superior to the regular signal light. The proposed modification is able to mitigate vibrations due to any type of wind (synoptic or non-synoptic) and is the first known effort to use the geometric characteristics of the signal light itself to mitigate the problem. The proposed modification is also an economical solution, as it does not incur any high costs associated with semi-active controllers.



Figure 1

Location and orientation of the monitored traffic signal structure in Ames, Iowa.

VERTICAL IMPEDANCE SCANNER FOR CONCRETE BRIDGE DECK ASSESSMENT WITHOUT DIRECT REBAR ATTACHMENT

NCHRP-IDEA Project 202

Brian Mazzeo [Tel.: (801) 422-1240, Fax: (801) 422-0201, Email: bmazzeo@byu.edu]

W. Spencer Guthrie [Tel.: (801) 422-3864, Fax: (801) 422-0159, Email: guthrie@byu.edu]

Brigham Young University, Provo, Utah

This project developed a multi-channel vertical electrical impedance (VEI) scanner with large-area electrodes to quantify the cover protection offered to reinforcing steel in concrete bridge decks without direct rebar connection (Figure 1). New electronics were designed to perform impedance measurements, localization, and automatic mapping of the impedance data. The large-area electrode developed for the VEI scanner system enabled data collection without direct electrical connection to the steel reinforcement. With collaboration from Utah DOT and Nebraska DOT, the scanner was extensively tested on several bare and overlaid concrete bridge decks in Utah and Nebraska. Field testing demonstrated that multi-channel measurements could be performed in parallel and that the use of the large-area electrode successfully eliminated the need for a direct electrical connection to the steel reinforcement. VEI scanning at rates exceeding 1,500 ft²/minute was achieved in these field tests. The VEI scanner can be used effectively on both bare and overlaid concrete bridge decks. For project-level bridge deck evaluations, this scanning device permits mapping of spatial variations in VEI to effectively guide additional, more localized testing, such as chloride concentration determinations. In conjunction with other techniques, the VEI scanner provides useful data to support decisions by bridge managers to select appropriate strategies from among preservation, rehabilitation, and replacement options available within their bridge management programs.

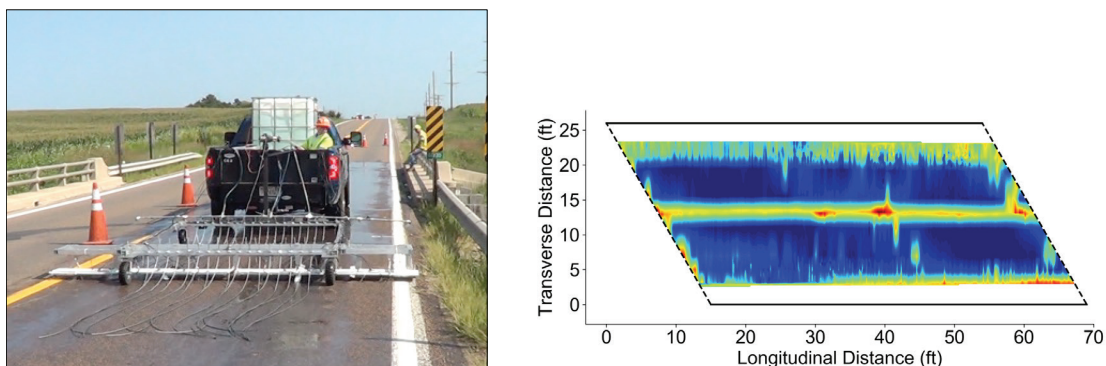

Figure 1

Vertical electrical impedance scanning (left) and mapping (right).

SAFERCUSHION

NCHRP-IDEA Project 203

Dean Sicking [Tel.: (205) 110-8133; Email: dsicking@uab.edu]

Kevin Schrum [Tel.: (205) 934-8470; Email: kschrum@uab.edu]

Blake Feltman [Tel.: (205) 934-8488; Email: bfeltman@uab.edu]

University of Alabama at Birmingham, Birmingham, Alabama

SaferCushion is a self-restoring crash cushion comprising a track and diaphragm system. Crash cushions have multiple categories, defined by their costs and the amount of effort needed to repair them. Some are inexpensive but are destroyed upon impact and, for locations with high collision frequency, the life-cycle costs can be exorbitant. On the other end of the spectrum, low-maintenance systems are expensive to install, but their low maintenance and repair costs make them a preferred option for high-frequency collision locations. The present study sought to advance the technology of these low-maintenance crash cushions through a truly automated procedure. First, an energy absorbing mechanism was designed that was capable of stopping an errant vehicle and resetting the system repeatedly (Figure 1). This was accomplished with a rotating drum that was resisted by band brakes. The rest of the structure of the crash cushion was designed to ensure that, for side impacts, weak-link design philosophy assured that the feet would fail before panels, diaphragms, and the track. This minimizes repair costs for extreme impacts with the face of the cushion. Also, a winch system was sized and tested that could reverse the direction of the drum, thereby pulling the compressed cushion back to its original position. The project concluded with crash tests using a bogey vehicle to ensure the drum could absorb the energy of the vehicle while still being able to reset and pull back into position. Commercialization of the SaferCushion is being explored. Highway safety manufacturers are being consulted for a transition into mass production and for rights to produce and sell the safety system, pending successful Manual for Assessing Safety Hardware (MASH) testing. The North Texas Tollway Authority is interested in a pilot installation program to evaluate the SaferCushion in the field.

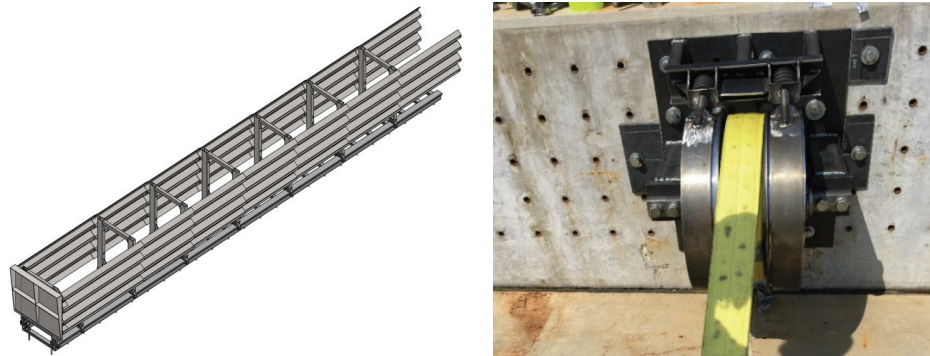

Figure 1

SolidWorks rendering of assembled structure (left) and energy absorbing mechanism (right).

BIO-MIMETIC ANTIFREEZE POLYMERS: A NOVEL BIODEGRADABLE DEICING SALT ALTERNATIVE

NCHRP-IDEA Project 204

Wil V. Srubar III [Tel.: (303) 492-2621, Email: wsrubar@colorado.edu]

University of Colorado–Boulder, Boulder, Colorado

The goal of this project was to design, synthesize, and test a class of bio-mimetic anti-freeze molecules with behavior similar to natural antifreeze proteins found in fish, plants, insects, and bacteria. The bio-mimetic molecules were evaluated for their effectiveness in (a) preventing or slowing ice formation and growth on roadway and bridge surfaces and (b) preventing frost damage in cement paste and concrete as an alternative to air entraining agents. A series of bio-mimetic antifreeze molecules (BAMs), both polymeric and small molecules that included polyvinyl alcohol (PVA); polyvinyl alcohol-polyethylene glycol-graft-copolymer (PVA-g-PEG); poly(2-hydroxyethyl methacrylate) (pHEMA); gelatin; folic acid; and citric acid, were evaluated for ice recrystallization inhibition (IRI) and freezing point depression activity. It was found that bio-mimetic antifreeze molecules would not effectively melt ice once ice has formed nor was there any additional synergistic benefit to using BAMs in tandem with conventional deicing salts. However, it was discovered that BAMs such as PVA and PVA-g-PEG inhibited frost damage in concrete (Figure 1) that appeared to be through a mechanism different from that of conventional air-entraining admixtures (AEA). This new bio-mimetic approach provides several key advantages over traditional AEA, including (a) retention of compressive strength by minimizing entrained air and (b) reduction of overall permeability, which subsequently leads to (c) increased long-term durability in chloride-laden environments. This IDEA research lays the scientific foundation for future research and development related to bio-mimetic antifreeze admixtures for use in concrete infrastructure prone to freeze-thaw deterioration.

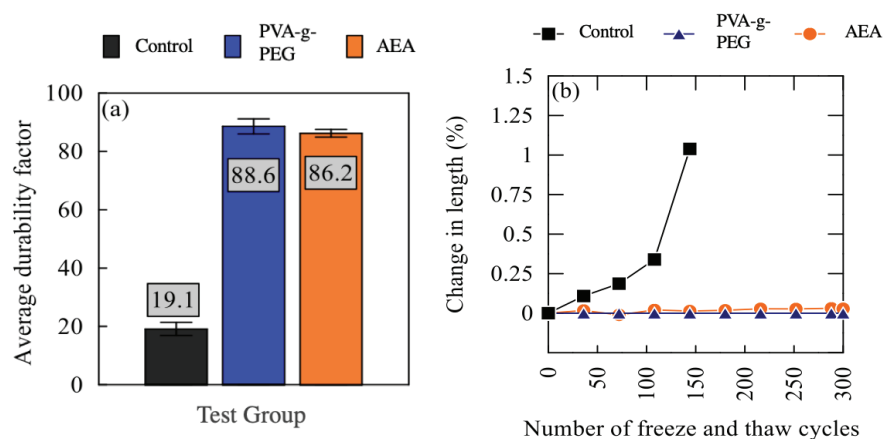

Figure 1

ASTM C666: (a) Average durability factor and (b) average length change for each test group. Error bars indicate standard deviation for $n = 3$.

MILDGLASS: GFRP STRANDS FOR RESILIENT MILD PRESTRESSED CONCRETE

NCHRP-IDEA Project 207

Antonio Nanni [Tel.: (305) 284-3461, Email: nanni@miami.edu]

Marco Rossini [Tel.: (347) 243-0701, Email: mxr1465@miami.edu]
University of Miami, Coral Gables, Florida, USA

Giovanni Dotelli [Tel.: +39 (02) 2339-3232, Email: giovanni.dotelli@polimi.it]
Politecnico di Milano, Milano, Italy

Saverio Spadea [Tel.: +44 (1382) 384357, Email: s.spadea@dundee.ac.uk]
University of Dundee, Dundee, United Kingdom

Corrosion of steel reinforcement is the primary cause of durability problems in aged reinforced concrete and prestressed concrete (PC) structures. This study aimed to develop a glass fiber reinforced polymer (GFRP) strand prototype (Figure 1a) to be applied in mild-prestressed concrete elements—MILDGLASS. GFRP bars are effective corrosion-resistant reinforcing solutions, but GFRP prestressing tendons are not available in the marketplace. Glass fibers are an efficient and cost-effective alternative to carbon fibers in applications that do not require high levels of concrete prestressing such as sheet piles, seawalls, bearing piles, and retaining walls. The technology implements electrical/chemical resistant (E-CR) glass fibers, vinylester (VE) resin, and explores thermoplastic (TP) resin to ease manufacturing of a twisted 7-wire geometry specifically optimized for prestress and allowing coilability and steel-like constructability. Coilable GFRP-VE and GFRP-TP round solid bars (Figure 1b) have been developed for prestressing as well. The GFRP strand does *not* alter the conventional fabrication process at the precast plant. The strand is coilable, shippable, and compatible with traditional techniques applied to steel-PC tensioning and construction. Due to the low level of tensioning as compared with ultimate strength capacity, no additional efforts or safety precautions are required at the plant, thus removing any barriers to large-scale implementation. Mild prestressing can be attained with conventional steel chucks, and the relatively low modulus of GFRP will result in elongations or movements of the stressing blocks of the same order of magnitude as with steel strands. The Florida Department of Transportation, a key stakeholder of MILDGLASS, is using GFRP prestressing in portions of a bridge and appears interested in leading nationwide prestandardization of the technology.



Figure 1

Geometrical configuration: (a) 7-wire GFRP-TP prestressing strand and (b) GFRP-TP round solid bar.

DETERMINING BRIDGE DECK CHLORIDE QUANTITIES WITH GROUND-PENETRATING RADAR

NCHRP-IDEA Project 208

Anthony J. Alongi [Tel.: (716) 731-4369, Fax: (716) 731-5040,

Email: anthony.alongi@penetradar.com]

Penetradar, Niagara Falls, New York

This project developed a new method for determining chloride quantity in bridge deck concrete using noncontact ground-penetrating radar (GPR) technology. The relationship between chlorides in concrete (which cause corrosion of reinforcing steel and delamination of concrete) and their effect on GPR signal propagation was investigated and defined. A GPR method was developed that, based on the measurement of signal loss or attenuation, provides a deck-wide topographical mapping of chloride concentration in concrete (Figure 1). The method entails a GPR scan of the entire bridge deck and the measurement of signal attenuation, along with a minimal number of core samples for laboratory chloride measurements to calibrate the GPR measurements. From the results, the correlation between GPR signal attenuation and chloride content could be reasonably defined with an R^2 value of 0.835, with only three chloride sample measurements. These results, confirmed through analytical modeling and laboratory experiments, show how chlorides and moisture in concrete affect the level of attenuation of radar signal. They also show that chloride level can be predicted by measuring signal attenuation, provided that moisture in concrete is known. With further development of this GPR method, it may be possible to accurately predict chloride quantities in bridge deck concrete by using radar measurements alone without the need for calibration cores. While initial results look promising, additional in situ tests are recommended to confirm the effectiveness of the method and to better define the accuracy on additional bridge decks and under a variety of environmental conditions.

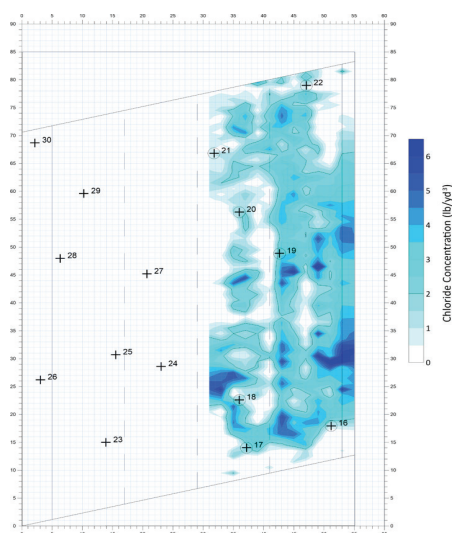

Figure 1

Bridge deck chloride content from GPR measurements, which is shown in a topographical format.

DEVELOPMENT OF NON-GATING TERMINALS

NCHRP-IDEA Project 212

Dean Sicking [Tel.: (205) 110-8133, Fax: (205) 934-8437, Email: dsicking@uab.edu]

Kevin Schrum [Tel.: (205) 934-8470, Fax: (205) 934-8437, Email: kschrums@uab.edu]

Blake Feltman [Tel.: (205) 934-8488, Fax: (205) 934-8437, Email: bfeltman@uab.edu]
University of Alabama at Birmingham, Birmingham, Alabama

Guardrail terminals have evolved to the point where they absorb energy while utilizing tension in the rail to countermand the compression. In this project, the possibility of a non-gating guardrail terminal was investigated (Figure 1). The primary benefit of such a guardrail terminal is the reduction in the number of serious injuries and fatal accidents associated with vehicles gating through that terminal. The key component of a non-gating guardrail terminal is the lateral restraint system that must be created and tuned to provide sufficient redirecting capability. One mechanism for providing this new redirecting capacity is to connect the impact head to a very tightly stretched wire rope. In this configuration, as the impact head is carried out of line with the guardrail, the wire rope will pull the front of the vehicle back toward the travel way. Lateral resistance provided by the wire rope is a combination of the tension in the cable and the spacing and stiffness of the posts to which the wire rope is attached. In this project, the combination of lateral and longitudinal forces that produce non-gating performance was determined from computer simulation. Next, a prototype terminal was crash tested. A terminal head was designed to deform guardrail, and its internal structure was adjustable to control the longitudinal force. Posts were designed to control lateral forces by modifying their section modulus. This controlled the force at which the posts buckled in response to a collision. A prototype was subjected to two 15-degree crash tests using an SUV (Ford Explorer) and a small car (Mazda Protégé). In both tests, the kinetic energy of the test vehicle was fully absorbed, and *Manual for Assessing Safety Hardware* (MASH) performance criteria would have been met. Neither vehicle passed beyond the terminal head, making these test results the first of their kind.

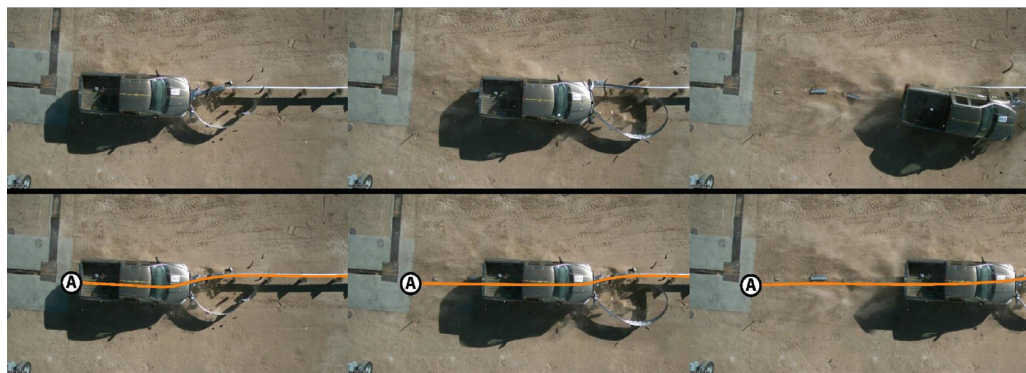

Figure 1

(Top) Gating: MASH 3-33 low angle impact sequence of a truck impacting a widely used gating end terminal. (Bottom) Non-gating: Digitally altered sequence of the same impact depicting the vehicle's reaction to a non-gating end terminal. This illustrates a cable being introduced into the system (orange line) that is anchored upstream of the impact head to the ground at Point A and another point downstream of the guardrail length-of-need.

SECTION 2

ACTIVE IDEA PROJECTS

This section reports progress on all Highway IDEA projects that were completed or active during the 2021 program year.

SELF-DE-ICING LED SIGNALS FOR RAILROADS AND HIGHWAY INTERSECTIONS

NCHRP-IDEA Project 190

Hongyi Cai [Tel.: (785) 864-2597, Fax: (785) 864-5631, Email: hycail@ku.edu]

Steven D. Schrock [Tel.: (785) 864-3418, Fax: (785) 864-5631, Email: schrock@ku.edu]
University of Kansas, Lawrence, Kansas

Eric J. Fitzsimmons [Tel.: (785) 532-0889, Fax: (785) 532-7717, Email: fitzsimmons@ksu.edu]
Kansas State University, Manhattan, Kansas

IDEA Concept and Product

This project has developed a new type of self-de-icing LED signal for highway signalized intersections and railroad signaling applications to solve a well-known problem of the existing LED signal light with lens too cool to melt snow and deice in wintery conditions. The snow-clogged signal lights can decrease the performance of signalized intersections and railroads and may result in collisions in inclement weather conditions. The self-de-icing LED signal light employs the innovative “Integrated Light and Heat Arrangement of LEDs in Low Profile” (Figure 1) to harvest both the light and the heat generated by the same LEDs for illumination and heating of the signal lens.

Project Results

The investigative approach is divided into three stages. Stage 1 focuses on laboratory research and development and tests of the prototype self-de-icing LED signals. The research team has developed and tested a total of five generations of prototypes of the self-de-icing LED signals (12 in.) in red, green, and yellow light colors. The research team has tested their thermal and lighting performance to meet all requirements. Stage 2 focuses on testing three fully working prototypes mounted in closed-course settings on the roof of an engineering building and powered by the signal controller cabinet, to avoid interruption on people and ground traffic. The research team has evaluated their thermal and lighting performance of the prototypes to ensure their readiness for follow-up field tests in winter. Stage 3 focuses on the field tests of the fully working prototypes on identified highway signalized intersections. The prototypes are installed on pole-mounted signals as backup to the existing primary signals. At each test site, the real-time performance of the prototype signals is monitored and recorded by a field-monitoring system using three cable cameras and four temperature sensors. Year-around test data (pictures and temperature data set) are recorded every 20 seconds in winter seasons [when the ambient temperature is lower than 4°C (39.2°F)] and every hour in summer seasons and stored on USB flash drives and also sent back to the team via remote cellular data transmission on daily basis. The collected field data are used for real-time performance evaluation of the new signals for future implementation in practice by the project partners.

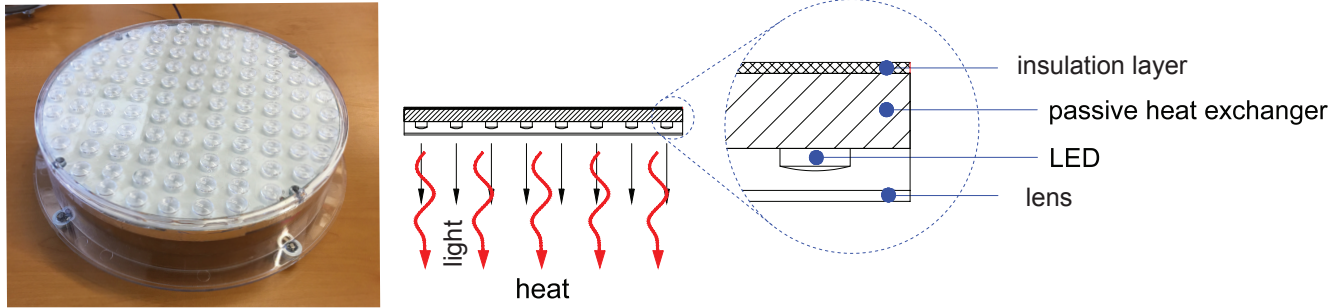

Figure 1

The concept and a prototype of the self-de-icing LED signal light, which deploys new architecture of “Integrated Light and Heat Arrangement of LEDs in Low Profile” (Patent Nos. US 10,215,441 B; US 10,253, 965 B2; US 9,851, 086 B2) to harvest both the light and the heat generated by the same LEDs for lighting and heating uses. The heat generated by the LEDs is harvested by the passive heat exchanger and stored to heat the lens for melting snow and de-icing in wintery conditions.

Product Pay-Off Potential

Once validated, the self-de-icing LED signal light is expected to be a viable replacement of the existing “cool” LED signal lights, the obsolete incandescent signal lights, and other emergent LED signal lights using additional heat generators and control sensors. If the self-de-icing LED signals are implemented in practice in the snow-belt states, transportation agencies, districts, and cities, the railroad companies and the driving public could expect significant benefits, including safety and efficiency, cost savings, and environmental sustainability. This system will not alter the function and sizes of the existing signal lights. There will be no need to add additional wiring inside and outside of the existing signal controller cabinets, and no need to change anything outside of the signal housing. The self-de-icing LED signal lights could offer savings on annual maintenance costs.

Product Transfer

Two patents were granted for the innovation of “Heated Lens Lighting Arrangement” (Patent Nos. US 9,851,086 B2 and US 10,253,965 B2). Another patent was issued for the innovation of “Integrated Light and Heat Arrangement of LEDs in Low Profile” (Patent No. US 10,215,441 B2). The research team and the University of Kansas Center for Technology Commercialization have been reaching out to the signal industry for patent licensing. Pilot replacement programs are planned to displace the existing signals with the self-de-icing LED signals in some collaborative state departments of transportation (e.g., California, Kansas, Maryland, Michigan, New Jersey, Pennsylvania, and Wisconsin), the Union Pacific Railroad, and the Burlington Northern and Santa Fe Railroad. Once validated, the self-de-icing LED signals are expected to be installed at highway intersections, Class I railroads, commuter railroads, and short-line railroads in cold weather zones.

SMART INSTALLATION AND MONITORING SYSTEM FOR LARGE ANCHOR BOLTS OF SUPPORT STRUCTURES FOR HIGHWAY SIGNS, LUMINARIES, AND TRAFFIC SIGNALS

NCHRP-IDEA Project 196

Jay Shen [Tel.: (515) 294-6473, Fax: (515) 294-8216, Email: jshen@iastate.edu]
Iowa State University, Ames, Iowa

IDEA Concept and Product

This study aims to develop an inexpensive, sensor-based system for monitoring tension in anchor bolts in support structures for highway signs, luminaires, and traffic signals (SLTS) to address the limitations of current practices for bolt installation and inspection. This smart washer system consists of two polylactic acid (PLA) 3-D-printed insulated attachments that cover the washers, with copper rings attached at each part, combined with a rubber ring in the middle to serve as dielectric material. Wires are connected through the PLA parts to the copper rings, and the other end of the wires can be connected to the measurement instruments.

Project Results/Planned Investigation

The project consists of two stages of research. Stage 1 focuses on the development of the calibration curve in the laboratory for the calibration of smart washer system, an initial tightening test on the PLA material was performed first to ensure the printed parts were able to withstand the clamping force without any damage that generated by the highest torque applied to the anchor bolts according to Minnesota DOT's newly implemented specifications. Tightening and loosening tests were performed on a Minnesota DOT Type V structure specimen, as shown in Figure 2(a), with capacitance and strain of anchor rods recorded, a pretension-capacitance calibration curve under room temperature (72°F or 22°C) was developed; in this way, any pretension value from 0 to the maximum required can correspond to a capacitance value, once a significant drop of capacitance (over 10%) is observed, the necessity of retightening can be determined by the maintenance crew.

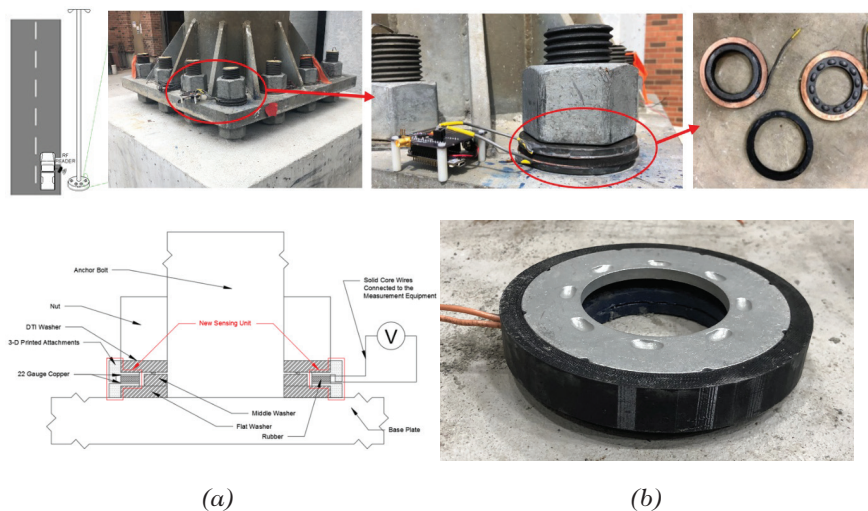

Figure 1

Smart washer system: (a) drawing of smart washer system and (b) assembled smart washer system.

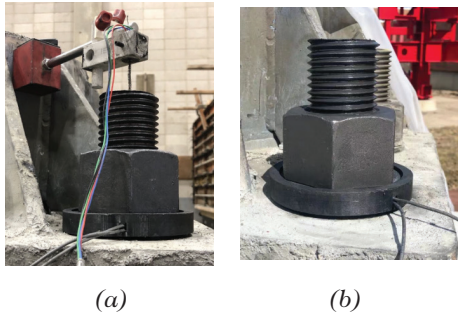

Figure 2

Testing and monitoring setup: (a) laboratory tightening and loosening setup for 2 1/2" Grade 55 anchor bolt, (b) outdoor monitoring setup for 2 1/2" Grade 55 anchor bolt.

Stage 2 focuses on the long-term performance of the smart washer system. After the testing in the laboratory, at the end of December 2020, the SLTS specimen was moved to outside of the laboratory to simulate the real on-site situation. And with the sensor system applied to the anchor bolts, as shown in Figure 2(b), when the anchor bolts were tightened, the capacitance and site temperature were recorded as the “reference base values”; at first, the site was revisited once a month to record the capacitance value, but after 3 months, to closely monitor the performance, the visit frequency has been changed to once a week. During each visit, the measurement instrument was connected to the sensor for at least 5 minutes and a continuous 120 seconds of capacitance measurement was cut out to be processed and compared with the reference base values; meanwhile, the site temperatures of each visit were also recorded, given that temperatures do have an impact on capacitance, especially higher temperatures during the summer. The first 6 months of monitoring show that the performance of the sensor system did not have significant change in capacitance, the maximum change was -3.41%; however, the site temperature was also recorded as the highest (88°F). Monitoring work is planned to be performed until the end of the project or until the sensor system fails, with a visiting frequency of once a week. This will be the major work for the remaining period of the project.

Product Pay-Off Potential

Anchor bolts are critical structural components of SLTS support structures. The collapse of SLTS structures has frequently been attributed to anchor bolt failures, often due to loose nuts. Therefore, the proposed research addresses an important, nationwide problem. The sensing washer system will provide accurate readings of capacitance values and can be interpreted to the tension forces experienced by anchor bolts using lab-developed calibration curves, which can help tell if the bolt is correctly tightened or has come loose. The proposed system has great potential to substantially reduce inspection costs and significantly improve safety by replacing current anchor bolt installation and inspection methods. The proposed system can be installed mostly with the current installation procedures and equipment, allowing an effective and easy installation. The proposed system could be modified, allowing for use in other types of bolted connections (e.g., bridges, buildings, wind turbines).

Product Transfer

The technology has attracted extensive interest from the industry, including TurnaSure LLC and Valmont Industries, Inc. It is believed that with proper portable measurement device design, the sensor system can be manufactured with a low cost and widely applied to the SLTS structures so that an efficient low-cost quality inspection and maintenance will be achieved.

BIO-INSPIRED “MRI” OF CONCRETE BRIDGES USING WAVEFORM-BASED ULTRASONIC TOMOGRAPHY

NCHRP-IDEA Project 205

Thomas Attard [Tel.: (702) 439-2417, Email: thomas.attard@powerpolymer.net]
PowerPolymer, LLC, Wimberley, Texas

Didem Ozevin [Tel.: (312) 413-3051, Email: dozevin@uic.edu]
University of Illinois at Chicago, Chicago, Illinois

IDEA Concept and Product

Current non-destructive techniques can accurately and discreetly identify sub-surface defects down to a depth of 2 cm, which severely limits possible deep evaluation of bridge damage, accurate bridge analysis and ratings, and the reliability of the retrofit design / preservation program. To address this limitation of the current technology, the original IDEA project tried to develop and test a multi-modal integrated technology, in which LiDAR would be utilized to detect possible surface damage (first pass), followed by magnetic resonance imaging (MRI) using non-destructive optimal radio frequency inductive testing (RFIT) to detect and discreetly locate deep defects/damage in concrete bridge components. Unfortunately, the method proved to be unreliable and unable to detect defects beyond a very minimal depth, in addition to not being able to differentiate voids and concrete. After revamping the project's objectives, this modified IDEA project will now develop and test an innovative waveform-based ultrasonic tomography to maximize defect (inclusions) resolution in heterogeneous materials (concrete) and concrete bridge components. The method will utilize a selection of ultrasonic frequencies and sensor arrays to scan large surfaces in performing a bio-inspired real-time bridge evaluation (akin to an MRI). As a result, the new alternate approach using an acoustic tomography approach using nonlinear waves shows preliminary promise, able to identify discrete defects at larger depths using 24-in deep concrete sections. This effort is in cooperation with the University of Illinois at Chicago (UIC).

Project Results

Using the elastic waves generated by ultrasonic signals that penetrate various structural media, the ultrasonic tomography method creates wave velocity distribution maps that are visual images of subsurface cracks. One of two evaluation methods may be used to determine the general tomographic inversion model: The ray-based method and the waveform-based method, in which the latter solves the fundamental wave equation and is widely adopted in the medical field due to its high resolution and accuracy. While linear ultrasonics has been successfully applied to detect the presence of defects such as cracking, corrosion, and voids in solids, *its resolution is limited by half the wavelength*. Nonlinear ultrasonics has the ability to detect defects using sub-wavelengths. The higher harmonics-based nonlinear ultrasonic method is established on the phenomenon, where the exciting signal is distorted by the nonlinear elastic response of the medium to predicate the incident wave, thereby producing a higher harmonic wave. In this project, an approach to generate linear and nonlinear tomography images using single measurement is developed. The measurement approach is based on decomposing the receiving ultrasonic signal into harmonics to develop time of flight (TOF) data from the time history of fundamental frequency, and an acoustic nonlinearity coefficient

from the amplitudes of fundamental and second harmonic frequencies. The schematic of the hybrid measurement approach is illustrated in Figure 1.

Preliminary results show that although a formulated ray-tracing linear algorithm may provide feasible results, the higher harmonic frequencies due to material heterogeneity will be best captured via waveform-based imaging, using nonlinear ultrasonics. Figure 2, *a* and *b*, shows waveform-based images for a concrete cylinder with an inclusion. Depending on the number and positions of the receivers to each transmitter (circled in green, Figure 2*a*), each (discrete) pixel will vary in accuracy for damage detectability, akin to finite element (FE) model meshing, from a perfect circle (ideal case, Figure 2*a*) to a rectangle (not as refined, Figure 2*b*). In this case, the nonlinear ultrasonic tomography output is measured by an acoustic nonlinearity coefficient to obtain a necessary frequency spectrum of concrete heterogeneities.

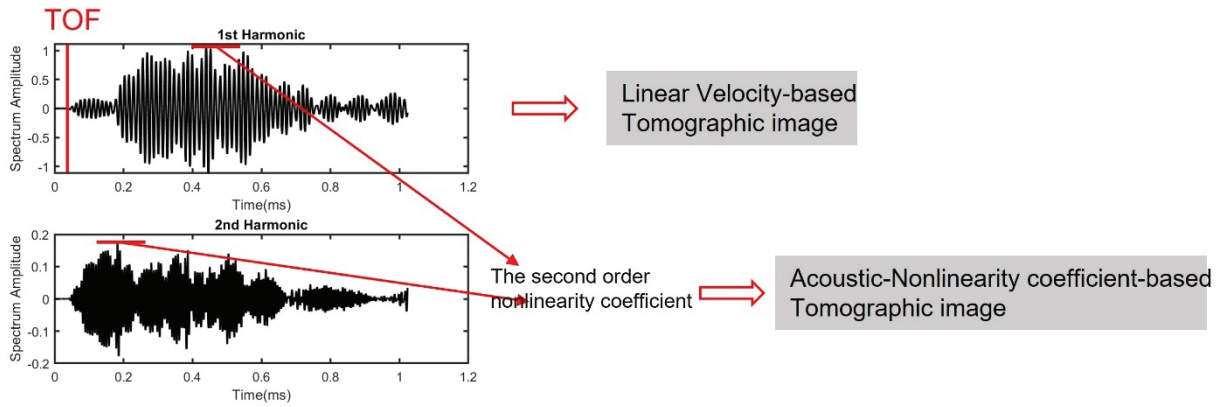

Figure 1

The schematic of extracting arrival time of the fundamental frequency (1st harmonic) to obtain the linear tomography and extracting the acoustic nonlinearity coefficient from a single measurement to obtain the nonlinear tomography (2nd harmonic). The combination of the two harmonics enables the excitation signal to generate an incident wave that adjusts in real time to accommodate the characteristics of the medium and to more accurately detect subsurface damage (image maps, including damage).

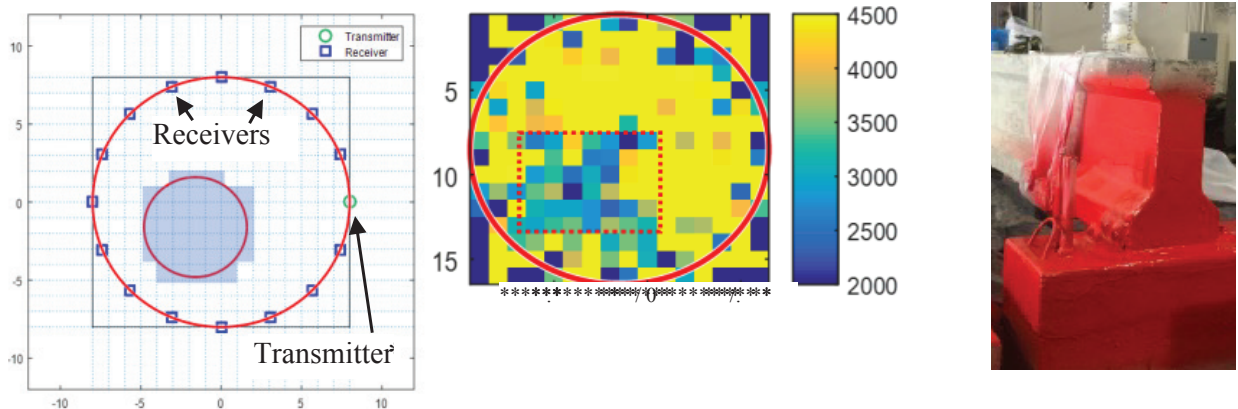

Figure 2

(a) Ideal, (b) calculated tomographic images of an inclusion shape in a concrete cylinder, and (c) HMC retrofit of the girder-to-cap-beam connection detail in a concrete bridge spanning tidal-influenced waters.

The waveform-based ultrasonic tomography is validated using a damage-simulated finite element model using COMSOL Multiphysics software. Then, the developed algorithm is tested using three calibration samples, as shown in Figure 3. The tomography of pure concrete has a uniform acoustic nonlinearity coefficient close to the lowest scale number. For the case of foam inclusions, a clear image to differentiate the regions with and without heterogeneities is obtained as compared with linear ultrasonic tomography. The blue region represents the homogenous concrete, whereas the light blue region indicates the heterogeneities. The detection of reinforcing steel is achieved successfully at the region with the brighter color, indicating higher nonlinearity, which coincides with the locations of reinforcing steel. The calibrated ultrasonic tomography algorithm will be subsequently used to assess subsurface damage in a post-tested concrete girder, retrofitted using a novel hybrid matrix composite (HMC) material at the girder-to-cap region. The PI at the University of Illinois at Chicago (Dr. Didem Ozevin) has already received the section girder (Figure 2c) from the PI at PowerPolymer, LLC (Dr. Thomas Attard). The retrofitted girder was previously tested under lateral wave and surge forces that had replicated scaled Hurricane Katrina forces. The novel HMC material (see the red region in Figure 2c) introduces critical energy-transferability properties to bridges to substantially improve the prognoses and life span of older bridges at a reasonable cost. To quantify this, the ultrasonic tomography method will be used to perform post-hurricane reconnaissance of the HMC material by imaging internal damage in the girder and ascertaining the projected functionality of the HMC.

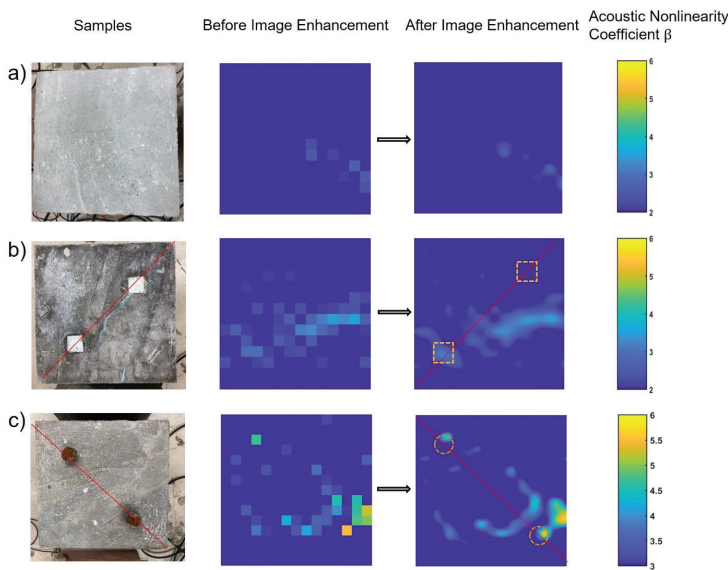

Figure 3

The experimental acoustic nonlinearity coefficient-based tomography images of three calibration samples: (a) pure concrete, (b) concrete with EPS foam inclusions, and (c) concrete with reinforcing steel.

Product Pay-Off Potential

This project will provide recommendations on possible implementation to local state and federal officials on the long-term prognosis effects of the evaluated/analyzed sub-surface damages detected in bridges. A cost-effective preservation or retrofit plan, for example, the HMC, will be developed in conjunction with initial bridge ratings and will be predicated on HMC composite design and cost-value function.

Product Transfer

This project will include a hands-on workshop to be coordinated by Thornton-Tomasetti for teaching end users about the ultrasonic tomography technology and the HMC as a recommended guideline. To facilitate product transfer to practice, field-testing of the ultrasonic tomography technology will be performed using a concrete bridge in Chicago (courtesy of Illinois DOT) The expected outputs of the workshop for end users are the following: (a) *practical tomographic imaging* (using a minimal number of sensors) of internal damage under large surfaces to improve deployment ease and accuracy; (b) enabling engineers to link damage-image profiles to computed residual bridge strength); and (c) providing needed information on *cost, applicability, functionality, and procurement* of ultrasonic tomography and HMC equipment to users/contractors.

RULE-BASED AUTOMATED SAFETY MONITORING SYSTEM FOR WORK ZONE SAFETY

NCHRP-IDEA Project 206

Kyungki Kim [Tel.: (770) 361-2262, Email: kkim13@unl.edu]

University of Nebraska-Lincoln, Lincoln, Nebraska

Omprakash Gnawali [Tel.: (713) 743-3356, Email: odgnawal@central.uh.edu]

University of Houston, Houston, Texas

IDEA Concept and Product

Due to the complex and changing work zone environment, it is difficult to recognize unsafe conditions that can potentially lead to fatalities or injuries. Utilizing various location tracking sensors, automated safety monitoring is considered one of the most promising solutions that allows continuous and accurate monitoring of work zones. However, commercially available sensing tools and recent research studies focus mainly on acquiring real-time locations without deriving meaningful information from it. This project develops a rule-based work zone safety monitoring system that enables a systematic and immediate interpretation of the location data. Two concepts are introduced to allow timely detection and prevention of safety hazards: (1) rule-based approach for real-time data interpretation; and (2) customization of new generation ultra-wide band (UWB) sensing. Completion of this project will lead to the development of tools supporting a new approach of monitoring highway work zone safety. Locations of all the objects with UWB tags (worker tags and equipment tags) will be calculated based on known locations of stationary UWB tags. Static unsafe zones (e.g., trench, slope, or outside the work zone) are registered by an onsite safety manager, and dynamic zones are created around moving equipment. Predefined rules automatically adjust parameters for hazard detection depending on the characteristics of related activities, status of equipment, and workers. The research team will integrate audio and vibration-alerting tools into the prototype system. These devices will be worn by workers and operators to give alerts.

Project Results

The project is being conducted in two research stages. Stage 1 focused on developing core functions of the proposed automated safety monitoring system, and the current Stage 2 integrates the individual functions and further optimizes the entire system through multiple field experiments. In Stage 1, three commercial UWB tracking devices [Radino two-way ranging (TWR), Sequitur TDOA, and Pozyx TWR] were tested in various scenarios where workers, equipment, and vehicles dynamically interacted. Field tests with equipment/vehicles identified critical limitations (such as insufficient location data points and inaccurate tracking of vehicles) of the UWB tools, which led to a new design of the Radino UWB TDOA system and overcame limitations.

In Stage 2, a Radino TDOA system was developed and upgraded in four versions that are called “baseline Radino TDOA,” “ViPER” (vehicle pose estimation using ultra-wide band radios), “signal-power selection,” and “ViPER+”. Key features of the last version include low-pass filtering for localization noise removal, dynamic reference anchor selection, and detection and resolution of Non-Line-of-Sight (NLOS) conditions. Figure 1 shows an outstanding performance of the last version of the system in a vehicle-tracking experiment. As can be seen in

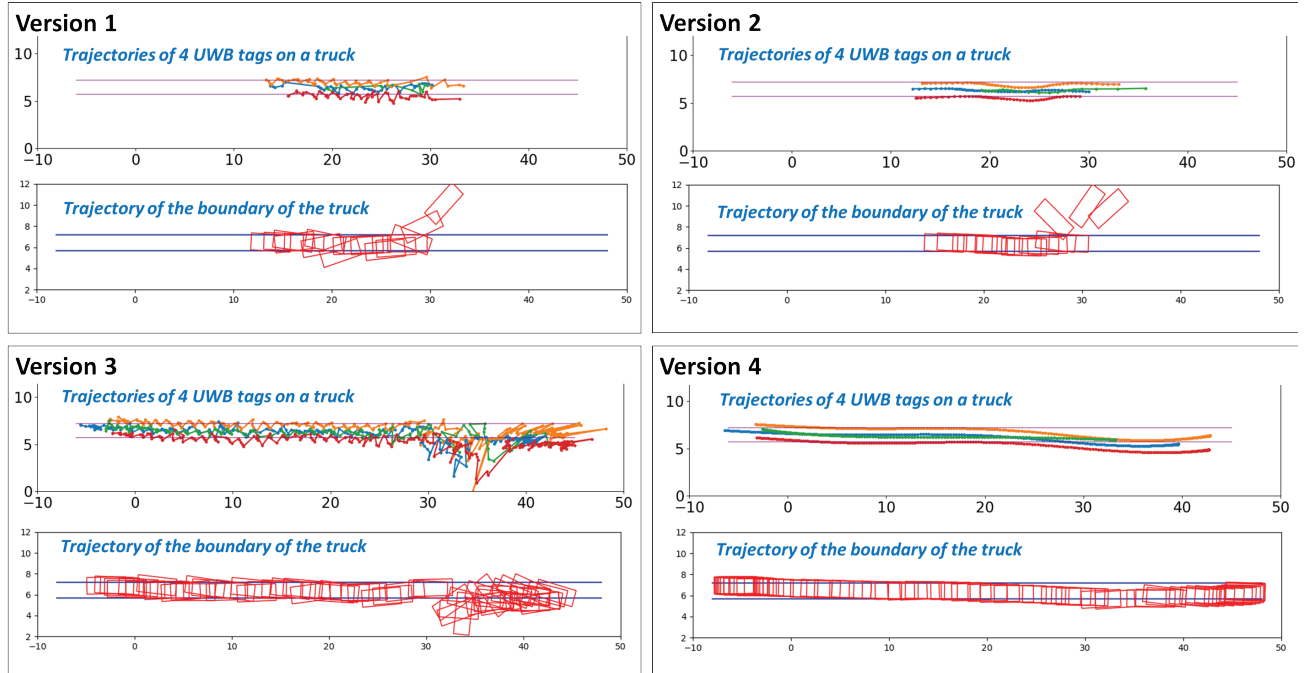

Figure 1

Results of tracking a pickup truck with four tags by using four versions of the Radino TDOA system.

Table 1, this version could track the location of the vehicle 99% of the entire trajectory, and localization errors were reduced from 53% in the first version to 13% in this fourth version.

During the remainder of the project, the vibration and sound-alerting systems will be integrated. The integrated system will be evaluated for accuracy, reliability, and other indirect measures (such as time, cost, required system infrastructure, and flexibility) to thoroughly assess its real-world feasibility. The research team will conduct interviews with state DOTs and industry partners to assess the system's usefulness and effectiveness in real-world situations.

A rule-based safety checking software program was also developed to analyze UWB location tracking results and detect unsafe situations (Figure 2). The software program was developed in a Unity game engine to support the creation of digital internal traffic control planning, in

Table 1
Performances of four versions of the Radino TDOA system.

	Pose reception rate (%)	Error rate (%)
Version 1. Baseline	27	53
Version 2. ViPER	49	26
Version 3. Signal-power selection	98	26
Version 4. ViPER+	99	13

Note: Pose reception rate is percentage of time during which pose estimate is provided by the system, and error rate is percentage of locations over 1 m location error and over 15 degrees of orientation error.

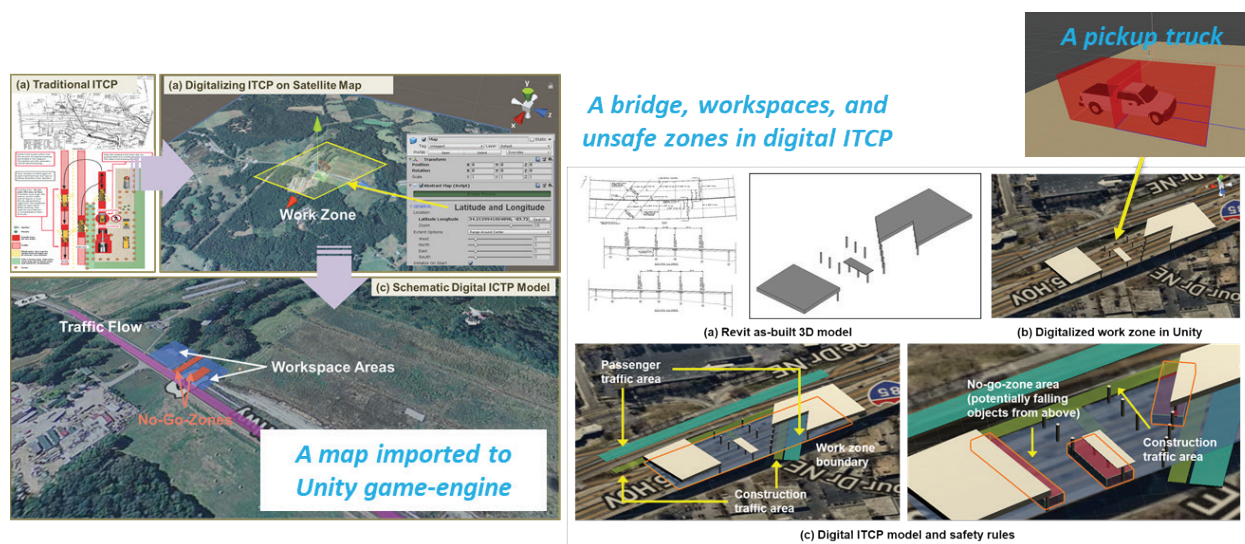

Figure 2

Work zone elements created in a digital internal traffic control plan.

which 3-D work zone elements are created in a game and locations of the game objects (e.g., workers and equipment) change by the result of localization.

Product Pay-Off Potential

Immediate benefits of this project are twofold. First, the process of monitoring the work zone can be automatically conducted by mobile sensors deployed to workers, equipment, and around the work zones. Instead of visiting individual activities, a safety manager can monitor the entire work zone. Second, meaningful interpretation of the location information is automatically derived based on predefined rules. This information will be valuable for on-site managers to make prompt decisions to protect workers, and also it will allow effective post-activity analyses. In the long run, the outcomes of this project will provide an important basis for future research studies and development of commercial applications. This project establishes a knowledge base comprising “if-then” statements. Also, optimal parameters, such as sizes of workspaces of workers and operators, will be identified throughout this project. The knowledge base can be extended for new types of safety hazards or adjusted based on project-specific conditions.

Product Transfer

The research team plans to transfer the outcomes of this project for implementation and potential commercialization. For that, it is closely collaborating with state DOTs, construction companies, a safety training provider, and a construction software vendor. More specifically, the research team will involve potential users from state DOTs and construction companies during the product development stage followed by trial implementations with the potential users. After the validation, the team will give a presentation and provide a small-sized demonstration session to state DOTs. All the information relevant to this project will be posted on a project webpage with a marketing video in order to introduce the project product to a wider range of potential users. Finally, the results will be presented in industry conferences in Houston, Texas, and before potential users to gauge their interest and the potential market size.

AN AUTOMATED SYSTEM FOR PEDESTRIAN FACILITY DATA COLLECTION FROM AERIAL IMAGES

NCHRP-IDEA Project 209

Yuanyuan Zhang [Tel.: (601) 266-5514, Email: yuanyuan.zhang@usm.edu]

Chaoyang Zhang [Tel.: (601) 266-5510, Email: Chaoyang.zhang@usm.edu]

Joseph Luttrell [Tel.: (228) 344-5795, Email: joseph.luttrell@usm.edu]

The University of Southern Mississippi, Hattiesburg, Mississippi

IDEA Concept and Product

The concept of this project is to build a prototype system to automatically collect data about major pedestrian facilities, including marked crosswalks and sidewalks, from aerial images. Collecting these data has been recognized as a high-priority action item in the states' strategic highway safety plans to meet the high need for improving pedestrian safety. To address this need, a novel data collection system is being developed to automatically detect, classify, and measure major pedestrian facilities. Aerial images will be input into the system where pedestrian facilities will be detected and measured using deep learning combined with traditional image-processing techniques. The final output will be information about paved sidewalk presence, marked crosswalk presence, and marked crosswalk length. This information will be stored for future integration into the existing roadway inventories owned by state DOTs. Figure 1 illustrates the system's concept.

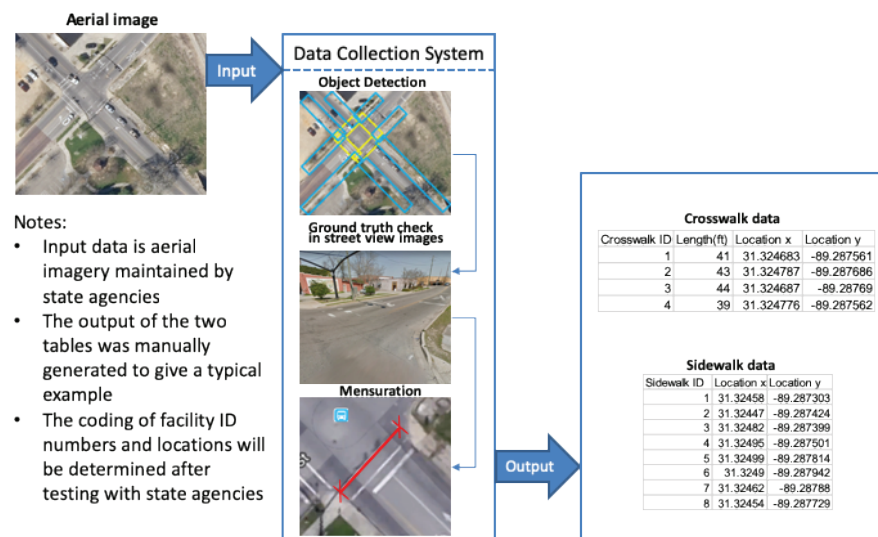

Figure 1

Illustration of the data collection system.

Project Results

The data collection system consists of four function models: (1) a “sample data acquisition model” for automatically acquiring labeled aerial images as training and testing samples; (2) a “facility detection model” based on deep learning methods for detecting and classifying non-occluded facilities; (3) an “occluded-facility-checking model” that smartly combines satellite view and street view information to check the ground truth for occluded facilities; and (4) a “mensuration model” to automatically measure the length or width of the target facility. Prototypes for all of these models have been completed. The facility detection model’s accuracy (acc) was evaluated for four different imagery targets, including aerial crosswalk (98.43% acc), aerial sidewalk (90.16% acc), street view sidewalk (89.02% acc), and street view crosswalk (84.81% acc). Testing the occluded facility detection model on a separate, heavily occluded data set revealed that utilizing dual-perspective data could increase detection accuracy by 49% (from 55.59% to 83.02%). More importantly, recall (the number of crosswalks discovered by the model) was increased by 383% (from 15.41% by using only the satellite view predictions to 74.42%). Currently, these models are being integrated into the final system, which will be able to apply their functions to all of the satellite imagery in a given area. Testing of the system and its user interface is being conducted with data from the Mississippi DOT, and the sidewalk detection capabilities of the facility detection model are being enhanced. Figure 2 shows an example of a single location in the testing data and the current crosswalk detection and mensuration capabilities of the final system. This includes a visual indication of the predicted location of the crosswalk drawn as a bounding box and the highlighted center point, and a full table of other prediction results (crosswalk length and width, the model’s confidence in its prediction, and the estimated coordinates of the predicted center point).



Figure 2

Current prediction results for an example location in DOT testing data.

Product Pay-Off Potential

The system has the potential to greatly reduce the costs for collecting pedestrian facility data by reducing the need for labor training, travel, observation, and record digitization, which are all required by manual data collection methods. The cost associated with the system is quite limited since the data sources used are free, and the training process only needs to be conducted once. Furthermore, using the proposed system requires just one staff member to input existing aerial images and monitor the results. The proposed system is expected to transform the way state agencies collect information not only about major pedestrian facilities but also other safety-related items, such as curb ramps, median refuges, and pedestrian signals, with future system enhancements.

Product Transfer

In order to make sure this prototype system will be developed as a foundation of a future tool used by state DOTs, participation of these agencies will take place in every stage of the project. During the development process, California and Mississippi DOTs have been providing sample aerial images for testing and analysis, and are assisting the research team to modify the system to interface with their DOT software and data management environments. They also provide guidance from the end users' perspective regarding data format, database structure, and geocoding. Once the development process is completed, these two state DOTs will assist in testing the system on their work sites. A user guide, oriented toward state DOT audience, will also be produced as part of the project report to make it easy for a first-time user to adopt this system.

MATERIAL CHARACTERISTICS OF CU-BASED SUPERELASTIC ALLOYS FOR APPLICATIONS IN BRIDGE COLUMNS TO IMPROVE SEISMIC PERFORMANCE

NCHRP-IDEA Project 210

Bora Gencturk [Tel.: (213) 821-1036, Fax: (213) 744-1426, Email: gencturk@usc.edu]
University of Southern California, Los Angeles, California

IDEA Concept and Product

In this project, the necessary underlying research is undertaken to characterize Cu-Al-Mn (CAM) superelastic alloys (SEAs) under all the relevant mechanical and environmental loading conditions to enable their application in bridges with the objective of improving bridge seismic performance. CAM SEAs have undergone major development over the last decade. They provide stable superelastic behavior at low and high temperatures, with recovery and rupture strains reaching 12% and 25%, respectively. CAM SEAs are available in sizes up to 30 mm in diameter, they are cost-effective, and they are easily machinable. In this research, the low-cycle fatigue characteristics, corrosion resistance, machinability, and coupling of CAM SEA bars to traditional steel rebar are being studied. If successfully demonstrated for their suitable characteristics, the CAM SEA bars could replace their NiTi counterparts at a significantly lower (up to 10 times) cost and accelerate their applications in bridges.

Project Results

Work in Stage 1 is assessing the mechanical properties and corrosion resistance of CAM SEAs. Twenty millimeter (mm) diameter CAM SEA bars were procured from the manufacturer. Single crystal CAM SEA bars were machined to dog-bone shape specimens, and polycrystalline CAM SEA bars were machined to 6 mm thick plates for long-term corrosion and low-cycle fatigue testing. Long-term corrosion tests involved subjecting the samples to a 5% by weight NaCl solution mist at 40°C in a corrosion chamber. Similarly, 20 mm diameter NiTi SEA bars were acquired from the manufacturer and machined to dog-bone-shaped samples for the low-cycle fatigue tests. Both CAM SEAs and NiTi SEAs were trained before being subjected to long-term corrosion or fatigue. The low-cycle fatigue tests with a 5% cyclic tensile strain amplitude are being performed at -40°C, 25°C, and 50°C on the single and polycrystal CAM SEAs and NiTi SEAs. Corrosion characteristics of CAM SEAs in a 1 M NaCl solution were measured through cyclic polarization testing. The results were used to derive the open corrosion, pitting and protection potentials, and Tafel slopes to determine the corrosion rates.

Up to 25% weight loss due to corrosion has been observed in #3 mild steel rebar samples over a duration of 300 days in the corrosion chamber during the long-term corrosion tests, while the weight loss due to the same exposure was 15% and 5% for the CAM SEA plates and bars, respectively. A cyclic tensile test on the corroded specimens was performed at certain intervals to determine changes in material properties. In addition to the traditional mild steel, the results are being compared with corrosion-resistant steels used in current practice, namely, stainless, epoxy coated, and high chromium steel. Despite some corrosion, CAM SEAs were observed to retain their superelastic behavior. Based on gravimetric weight loss measurements performed to date, CAM SEAs were found to be approximately 2 times more corrosion resistant than mild steel rebar and approximately 1.5 times more than high chromium steel rebar,

while stainless and epoxy coated steel rebars essentially showed no corrosion. Preliminary low-cycle fatigue testing results indicate that the single crystal CAM SEA bars are capable of going through tens of thousands of cycles prior to rupture even though their superelastic characteristics degraded more quickly (see Figure 1). Additionally, the same performance was shown by the single-crystal CAM SEAs at all the testing temperatures while the NiTi alternative did not show superelastic behavior at subzero temperatures. The fatigue performance of polycrystal bars was found to be highly variable due to differences in the grain orientations, boundaries, and sizes.

In the second phase of the project, mechanical bar splices to join a 20 mm and a 30 mm CAM SEA bar with a 19.05 mm (#6) and a 32.26 mm (#10) steel rebar, respectively, are being tested. Additionally, 20 mm and 30 mm CAM SEA bar are being spliced with 20 mm and 30 mm CAM SEA bars to overcome manufacturer's limitation of producing bars longer than 300 mm. Heading rebar coupler methodology is being used to couple CAM SEA bars with the steel bars. The effect of heat treatment of CAM SEA bars before and after heading is being investigated. Several coupling tests between the conventional reinforcing steel and the CAM SEAs were conducted. It was found that the brittle failure induced from rebar heading method could be eliminated through proper heat treatment without compromising the mechanical properties of the CAM SEAs. The machinability index of CAM SEAs will be determined in the upcoming quarters by using both tool life method and abrasion production rate. A quantitative cost estimation of both single crystal and poly crystalline CAM SEAs will be made and compared with those of the NiTi SEAs and conventional steel rebars. In this estimation, the cost of raw materials (based on the alloy percentages), the costs associated with the fabrication process, and the cost of amount of materials (both concrete and reinforcement) needed in a bridge column designed to the same strength will be accounted for.

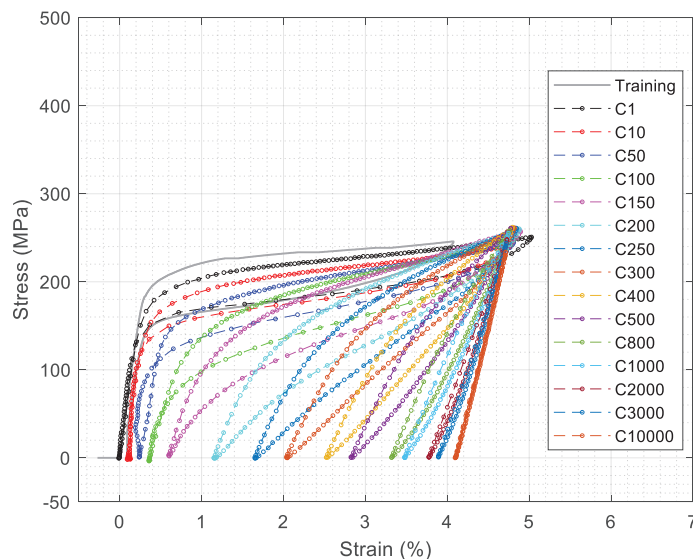

Figure 1

CAM SEA going through 10,000 tensile strain cycles of 5% without failure.

Product Pay-Off Potential

This project will test the sufficiency of material performance of CAM SEAs for use in bridge columns. The project addresses a high priority need of state highway agencies, as the functionality of transportation infrastructure is essential following an earthquake. This project can save state highway agencies millions of dollars in direct and indirect costs should a major earthquake happen. With more cost-effective and easier-to-implement SEAs, the number of bridges with SEA reinforcement could increase quickly, resulting in a safer and more resilient national transportation network.

Product Transfer

The project advisory board comprises several DOT engineers from states with high seismicity risk. The research team is investigating the potential of a follow-up implementation project once the CAM SEAs have proved to perform satisfactorily under all relevant loading and environmental conditions.

REDUCING STORMWATER RUNOFF AND POLLUTANT LOADING WITH BIOCHAR ADDITION TO HIGHWAY GREENWAYS

NCHRP-IDEA Project 211

Paul Imhoff [Tel.: (302) 831-0541, Fax: (302) 831-3640, Email: imhoff@udel.edu]
University of Delaware, Newark, Delaware

IDEA Concept and Product

In this study, the reduction of stormwater runoff by biochar amendment to the soils of highway greenways is examined. Biochar is a charcoal formed by combusting waste organic matter in an oxygen-limited environment. Amending biochar to highway soils may increase total porosity and water retention, increase soil aggregation and infiltration rate, and enhance sorption and transformation of pollutants. However, biochar's effect on stormwater runoff and pollutant loading reduction varies with soil type, biochar type, and time. In this project, the dynamic effect of biochar amendment to roadway soils across a wide range of geographic locations on increasing soil aggregation, stormwater infiltration, and runoff reduction will be monitored and tested. Results will guide DOTs to determine for which soils biochar amendment is a cost-effective stormwater management option.

Project Results

To evaluate biochar's effect on soil aggregation and stormwater infiltration, 12 roadway soils were collected with assistance from the California, Delaware, and North Carolina DOTs and the Maryland Transportation Authority. Laboratory columns were packed with soils with and without 4% mass-ratio biochar, and biweekly storm events were conducted for 20 months to assess if biochar amendment increases stormwater infiltration. The magnitude of steady-state effective-saturated hydraulic conductivity (K_{sat}), which is a measure of stormwater infiltration, varied significantly among different treatments (0.022- 14.7 cm/h). Biochar addition increased the effective K_{sat} for 4 soils (33% of total), had no impact for 1 soil, and reduced the effective K_{sat} for 7 soils (58% of total soils). See Figure 1. A general trend was that for the soils with low effective K_{sat} , biochar improved the effective K_{sat} and for soils that already had high effective K_{sat} , biochar decreased effective K_{sat} and infiltration. The generally observed trend was that biochar increased K_{sat} for coarse-textured soils and reduced it for fine-textured soils. Another interesting trend was that for 8 of 12 soils, the biochar-amended soil hydrologic performance with respect to biochar-free soil improved over time, which implies that the biochar addition may benefit more over time than what is reported here. We also characterized biochar's effect on the important properties that can influence the soil effective K_{sat} . These properties are soil texture, bulk density and porosity, aggregate size, cracking, and swelling. The addition of biochar decreased soil aggregate size, swelling, and cracking and increased soil porosity.

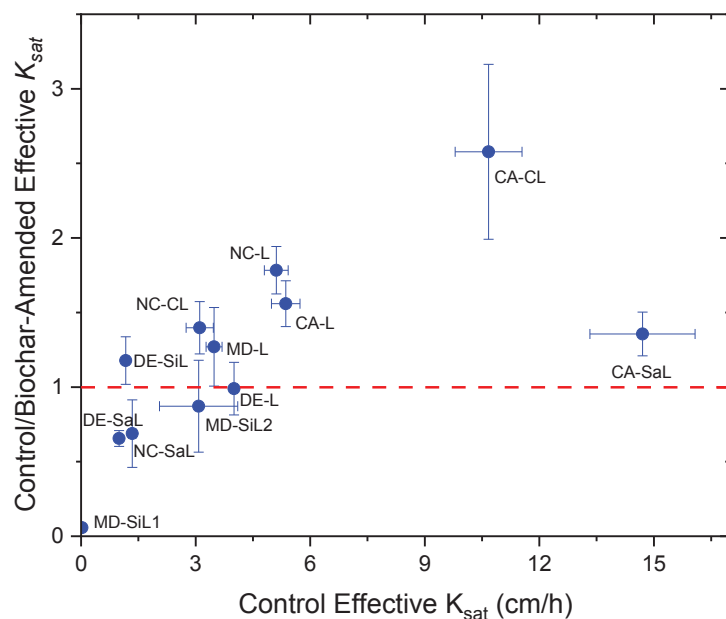

Figure 1

The ratio of control (without biochar) to biochar amended effective K_{sat} versus the control effective K_{sat} for the entire measurement time in laboratory column experiments. Data points are the mean of the measurements during the entire experiment. SaL, SiL, CL, and L are sandy loam, silt loam, clay loam, and loam soils, respectively.

The impact of wood-based biochar on soil structural and hydraulic properties is also reported in a field study with a sandy loam soil (supported by the National Fish and Wildlife Foundation) and another field study with silt loam soil (supported by the Maryland Transportation Authority). The soils were the same soils used in the laboratory experiments. As shown in Figure 2, in both field settings the addition of biochar improved effective K_{sat} (by 31% for sandy loam and 9177% for silt loam soil). The trends for changes in K_{sat} and bulk density in the field were identical to that in the laboratory. However, the change in aggregate size was the opposite in the laboratory and in the field: while biochar increased the aggregate size in the field, it reduced the aggregate size in the laboratory for both soils. Thus, although the laboratory column experiments captured the changes in hydraulic properties, they did not capture the change in perhaps the most soil structural properties (i.e., aggregation). Therefore, the laboratory procedure should be modified in the future to better capture soil aggregation in the field. Without any modifications, the laboratory test procedure developed in this study provides a conservative (low) estimate of biochar's benefit on stormwater runoff reduction in field applications.

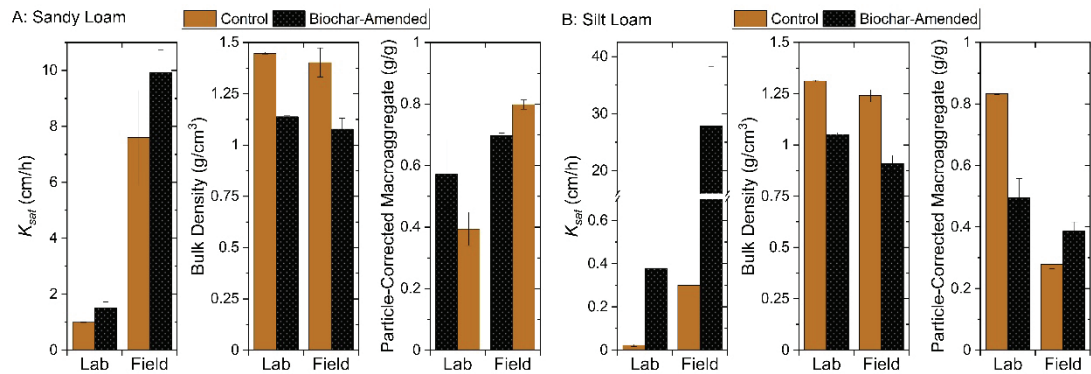

Figure 2

Comparison between K_{sat} , bulk density, and particle-corrected macroaggregates fraction under the laboratory and field conditions for (a) sandy loam (DE-SaL) and (b) silt loam (MD-SiL1) soils.

Product Pay-Off Potential

The laboratory column and pilot-scale experiments provide a fundamental understanding of the influence of biochar amendment on time-dependent soil aggregate formation and hydraulic properties for a range of representative roadway soils. Using new costs determined from recent field-scale implementation, 0.12 acres of biochar amendment is needed to treat 1-acre impervious with approximately 83% removal of nutrients and sediments at a cost of ~\$34,600 per impervious acre treated, a standard metric for assessing BMP performance. A cost analysis comparing biochar amendment to 25 BMPs indicates that biochar is less expensive than 21 other BMPs – up to 10 times less. Biochar amendment is more expensive than only four BMPs: erosion and sediment control, street sweeping, wet ponds and wetlands, and urban grass buffers. However, utilization of these BMPs may be limited, for example, because of land area needed and other constraints like existing slope and buffer width available for urban grass buffers. While biochar costs are similar to urban grass buffer (\$26,600 per impervious acre), biochar amendment requires a dramatically smaller footprint: 0.12 versus 3.7 acre per impervious acre for biochar and urban grass buffer, respectively. Thus, while these less expensive BMPs should be used where applicable, they are often insufficient to achieve necessary control of sediment and nutrients, in which case biochar amendment could be used.

Product Transfer

In collaboration with the Delaware DOT and the Maryland Transportation Authority, in 2020 the team installed field-scale demonstration projects for biochar amendment to transfer the results from this study to the field. In addition, the team submitted (July 2021) an NCHRP Implementation Program proposal for demonstration projects in California and North Carolina. Information from these demonstration projects will be used to obtain regulatory approval for stormwater treatment credits in these states, thus establishing this technology.

SEAHIVE—SUSTAINABLE ESTUARINE AND MARINE REVETMENT

NCHRP-IDEA Project 213

L. Rhode-Barbarigos [Tel.: (305) 284-3490, Email: landolfrb@miami.edu]

B. K. Haus [Tel.: (305) 421-4932, Email: bhaus@rsmas.miami.edu]

A. Nanni [Tel.: (305) 284-3461, Email: nanni@miami.edu]
University of Miami, Coral Gables, Florida

IDEA Concept and Product

The project is centered on the structural morphogenesis of a novel modular seawall/riprap system, called SEAHIVE. The system is composed of a series of perforated tube elements that can be stacked horizontally or vertically allowing the system to adapt for various applications and topography, while perforations along the length of the elements allow wave energy to dissipate within them, thus increasing material efficiency and performance (Figure 1). Cement with seawater and non-corrosive reinforcement rebars is explored for SEAHIVE fabrication to avoid corrosion and ensure a good integration with the natural environment. Moreover, elements at higher elevations can be filled with sand and soil to promote coastal vegetation, creating a protective environment for marine life to thrive. It is thus expected that the SEAHIVE system will be an efficient and ecofriendly seawall design.

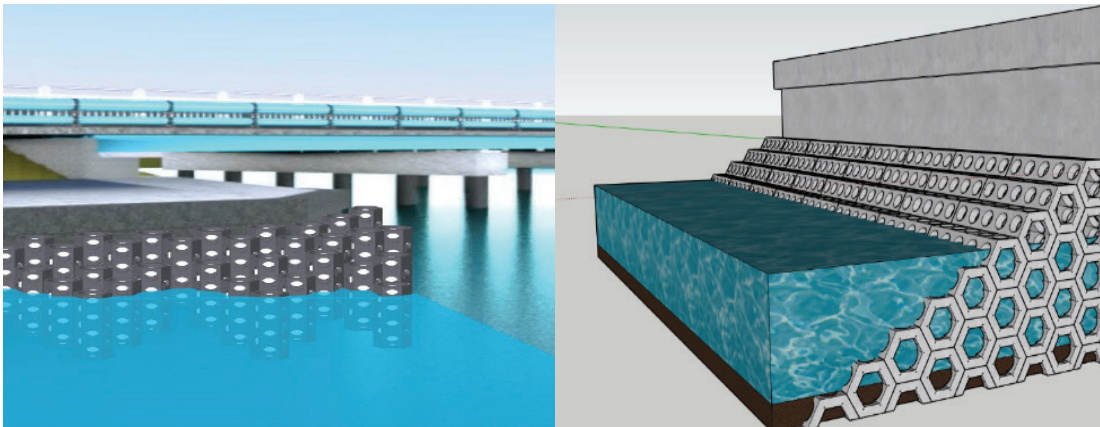

Figure 1

Illustration of SEAHIVE system applications.

Project Results

SEAHIVE is currently under development through physical testing at the University of Miami, Surge STructure Atmospheric Interaction (SUSTAIN) Facility (Figure 2) and an auxiliary material study on biocompatibility. SUSTAIN is a wind-wave tank that can generate directionally varying waves using a 12-paddle system combined with direct wind forces, simulating hurricane conditions up to Category 5 on the Saffir-Simpson scale. It thus allows physical testing of SEAHIVE elements at near-full-scale conditions, as well as scaled system configurations, providing a unique opportunity for experimental validation of the system's performance under varying wave conditions and water levels as well as extreme tidal conditions.

Stage 1 investigations focused on testing SEAHIVE element models in SUSTAIN. Elements with square, circular and hexagonal cross-sectional profiles and circular perforations that varied in diameter and/or void wall surface over solid surface ratios were thus tested under a variety of wave conditions for load definition, optimization of the outer profile, void configuration for wave energy dissipation, and performance characterization through pressure, water velocity, and wave height measurements. Testing conditions were defined based on a dimensional analysis of the Froude number between wave history data from four locations/zones within the United States and the experimental models designed for the SUSTAIN tank. Data analysis revealed differences in pressure and water level measurements among the SEAHIVE element configurations tested. Differences in pressure, both in magnitude and distribution, between the elements are attributed to differences in the projected areas of the elements perpendicular to the wave direction, the presence of perforations (i.e., placement and void ratio) along the elements, as well as to the flow field around the elements.

Work in Stage 2 of the project focuses on the characterization of SEAHIVE system performance for different system configurations. In light of the COVID-19 pandemic, Stage 2 experimental testing in SUSTAIN and the auxiliary material study on biocompatibility have been postponed and are expected to resume in Fall 2020. Material samples were recovered after an 8-month period under water in Biscayne Bay, Florida.

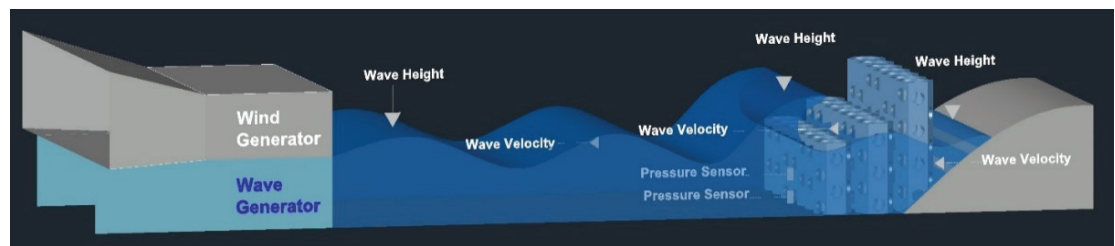

Figure 2

Illustration of the physical testing of SEAHIVE at the University of Miami SUSTAIN Facility.

Product Pay-Off Potential

This project aims toward the development of an efficient and cost-effective shoreline protection system for areas with high energy tidal flow, with adaptive features for various applications and topography that creates an ecofriendly environment for marine life. Efficiency is obtained by employing a profile shape and perforation configuration that ensures good stability while increasing wave-energy dissipation capabilities with physical testing at SUSTAIN used to ensure effectiveness at various conditions, including high tidal flow. Element shape tuning and modularity are expected to allow the system to be used for a wide variety of applications, while material selection and structural complexity can ensure a good compatibility with the natural environment. Finally, cost-effectiveness can potentially be obtained by adopting traditional concrete pipe fabrication technology for element fabrication.

Product Transfer

The SEAHIVE system is still under development with expected project completion postponed to Fall 2021. Over the past year, the developing team has made significant progress toward product transfer and implementation with two pilot studies currently in progress. The first study employs SEAHIVE as an alternative to traditional rubble riprap at the toe of a newly constructed seawall in North Bay Village, Florida, while the second study uses the SEAHIVE elements for the construction of an artificial coral reef along the shore of Miami Beach, Florida (Figure 3). The developer has continued to receive inquiries from cement manufacturers and ready-mix producers, as well as from local stakeholders and the private sector. Product transfer and implementation efforts will continue and are expected to intensify as the product design will reach its final development stage and with the completion of the construction for the pilot studies.

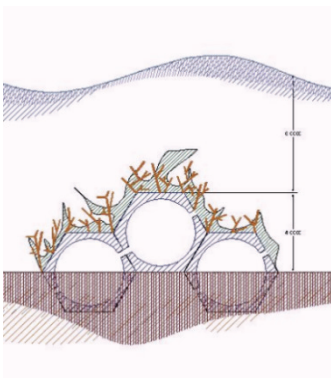

Figure 3

Illustration of the SEAHIVE system for the artificial coral reef application.

AN ENHANCED NETWORK-LEVEL CURVE SAFETY ASSESSMENT AND MONITORING USING MOBILE DEVICES

NCHRP-IDEA Project 214

Yichang (James) Tsai [Tel.: (404) 385-6428, Email: james.tsai@ce.gatech.edu]
Georgia Institute of Technology, Atlanta, Georgia

IDEA Concept and Product

A disproportionately high number of serious vehicle crashes occur on horizontal curves (25% of fatal crashes), even though curves represent only a fraction of the roadway network (5% of highway miles). This project addresses an urgent need for network-level curve safety assessment. The current methods are labor-intensive, time-consuming, and often dangerous for the engineers collecting the data. This significantly hinders transportation agencies' capabilities for applying proactive safety improvements at the right time to reduce the number of crashes on curves. This project develops an enhanced method (Figure 1) that enables transportation agencies to assess network-level curve safety conditions safely and cost-effectively by collecting and analyzing vehicles' global positioning system (GPS) trajectories and kinematic data using intra-agency, crowdsourced, low-cost mobile devices (smart phones). Compared with the current methods, the proposed method improves data accuracy by utilizing the inertial measurement unit (IMU) data to obtain the precise motion of the vehicle and by considering the vehicle's suspension property in calculations that can be obtained through proposed calibration procedures. The proposed method also improves data collection productivity by using hundreds of state DOT vehicles equipped with low-cost mobile devices, instead of a limited number of dedicated devices; reduces data collection costs by using non-dedicated vehicle drivers to collect data while they are performing other tasks; and is safer than the current methods because a driver does not have to maintain a constant speed on curves. Most importantly, the proposed method will collect and process the crowdsourced data in a timely manner (e.g., daily, weekly, monthly, but not yearly) to identify the targeted roadway sections with safety improvement needs that require detailed assessment (say 5% instead of 100%) for engineers to confirm in the field so transportation agencies can save money and time in condition assessment for taking the safety improvement action in a timely manner to cost-effectively reduce curve crashes. To ensure data quality and ease the concerns on privacy, crowdsourcing data collected from the fleet and employees in a single transportation agency, that is, an intra-agency, is recommended.

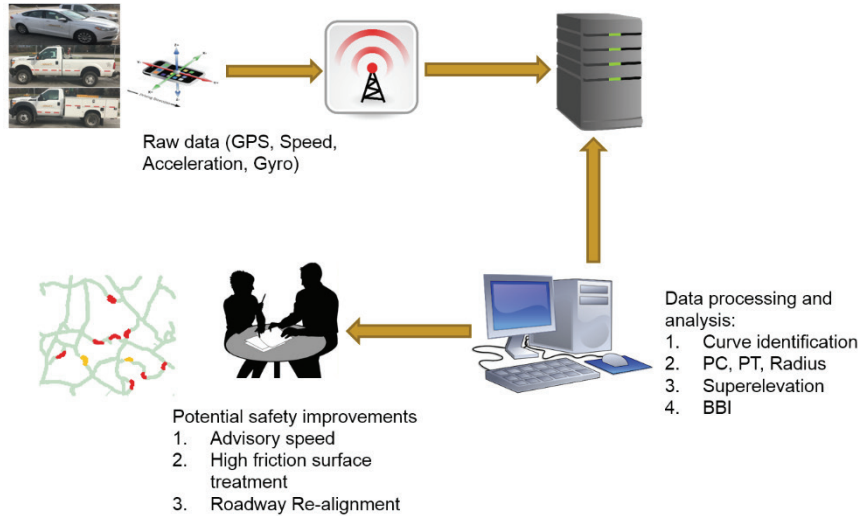

Figure 1

Operation flow of network-level curve safety assessment. PC = point of curve, PT= point of tangent, and BBI = ball bank indicator.

Project Results

This study proposes a method with a data collection and computation framework, which consists of the following six modules: (1) mobile data collection, (2) mobile data registration and processing, (3) driving kinematics calculation, (4) curve geometry calculation, (5) advisory speed calculation, and (6) curve warning sign design. The calculations of the required data items for curve safety assessment are based on the kinematic relationship between the vehicle's cornering behavior and curve geometry.

A mobile device application was explored for the Android operating system for low-cost, frequent, and crowdsourced road infrastructure condition data collection. The application integrates and stores data from multiple smartphone sensors already included in modern mobile devices, including camera video, GPS, IMU or internal measurement unit, and estimated orientations (Figure 2).

This study shows that the data collected by the mobile devices are sufficient for BBI angle and superelevation estimation; this study also shows that the superelevation measurement accuracy can be impacted by the vehicle's body roll at different speeds. Therefore, this study proposed calibration methods to estimate the data collection vehicle roll rate to account for the vehicle's body roll in refined superelevation calculations.



Figure 2

Data collection using smartphones.

To validate the proposed data collection and computational framework, a validation test was performed at the National Center for Asphalt Technology (NCAT) test track to evaluate the performance of the framework (Figure 3). NCAT is an ideal test location since it is a controlled site, and the true curve geometry can be measured or obtained from design drawings. Multiple superelevation measurements were taken from the NCAT test track to use as ground references. The test results show that, without using the calibration methods to estimate the vehicle's roll rate, superelevation measurement accuracy continuously decreases with increasing speed, up to a root mean square error (RMSE) of 3.2% slope at high speed. The results after calibration show that, using the proposed method, the superelevation results from smartphones can consistently achieve an RMSE of 1.4% – 1.5% slope at different data collection speeds. The validation test also shows that with a good quality centerline, the estimated curve radius is very close to the curve radius from the curve design drawings. In summary, the advisory speed computed for the NCAT test track using the proposed method, with calibration, is only 1 mile per hour off from the advisory speed determined from the manually measured superelevation. This demonstrates that the proposed method can accurately capture the curve geometry to determine appropriate curve advisory speed.



Figure 3

Validation test performed at the National Center for Asphalt Technology.

Product Pay-Off Potential

If successful, the proposed method will provide a low-cost means to perform a preliminary network-level curve safety screening on a daily or weekly basis. The proposed method can be used by state DOTs to assess curve conditions while they are working on other tasks. Once roadway sections in need of curve safety improvement are identified, a detailed curve safety assessment can be conducted on only the identified targeted sections. This enables transportation agencies to focus their time and attention on targeted roadway curve sections that need improvement and not on those that do not need improvement. The proposed method is expected to significantly reduce the cost and time spent by state DOTs in assessing their network-level curve safety conditions, including BBI computation, super-elevation computation, advisory speed determination, and pavement surface treatment determination, by using crowdsourced, low-cost mobile devices, such as smartphones and tablet personal computers. In addition, this cost-effective method will be specifically useful for counties and cities with limited resources.

Product Transfer

Several state DOTs have committed to participating in this research and will support this study by collecting and providing the necessary data. Their personnel will work with the research team to validate the results obtained in this study. In addition, the Georgia DOT provided a cost share on this study, with a focus on collecting the data using the Georgia DOT's vehicles to support the development of calibration and validation procedures. Once the algorithm and the method have been developed and proved to be feasible through this research study, software products will be developed in the future to promote the developed technology and offered to other state DOTs with a pilot study to further test and refine the proposed method for future implementation.

ACHIEVING RESILIENT MULTI-SPAN BRIDGES BY USING BUCKLING-RESTRAINED BRACES

NCHRP-IDEA Project 215

Michel Bruneau [Tel.: (716) 645-3398, Email: bruneau@buffalo.edu]

Homero Carrion [Tel.: (716) 445-8184, Email: homerofe@buffalo.edu]
University at Buffalo, Buffalo, New York.

IDEA Concept and Product

The objective of this NCHRP-IDEA Type 2 project is to make the bidirectional ductile diaphragm concept applicable to common multi-span bridges as a way to prevent damage in the substructure and superstructure due to earthquake excitation. The concept uses energy-dissipating buckling restrained braces (BRB) as “fuses” or sacrificial elements located at the end of the superstructure’s floating spans. The viability of the concept was initially demonstrated in a NCHRP-IDEA Type 1 project for single-span bridges. Figure 1 shows different configurations of the energy dissipation system. The current project aims to expand the concept to multi-span bridges through analytical and experimental research. Therefore, this project is a final step to expanding the use of ductile diaphragms (already implemented in the AASHTO Seismic Specification but limited only to transverse excitation applications), to provide resistance to bidirectional excitation, in multi-span bridge configurations. This innovative system using BRBs can provide seismic resilient and damage-free bridges applicable to different levels of seismic forces at low cost as a result of the availability of BRBs in different capacities ranging from 20 to 1,400 kips and already tested for building use purposes.

Two main problems, however, prevent the implementation and broad use of this concept, which will be addressed in this project: (1) the need to understand analytically the behavior of the system in a multi-span configuration, to be able to propose a simple design procedure; and (2) the need to validate experimentally BRB connections to demonstrate their ability to work under 3-D displacements imposed due to the inclination of BRBs.

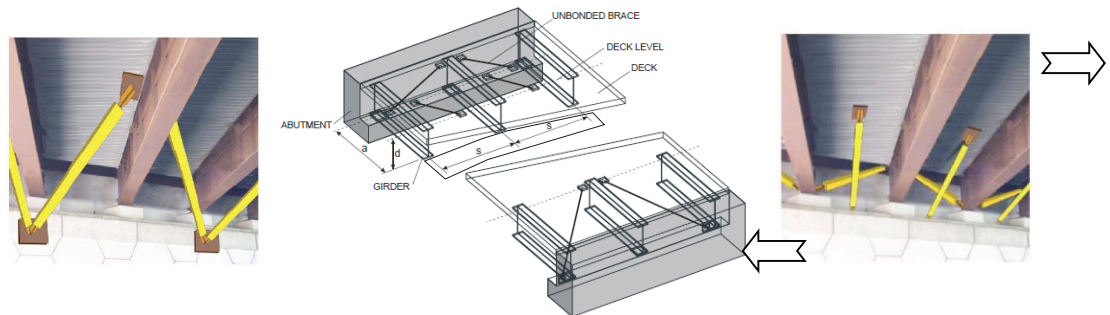

Figure 1

Conceptual illustration of the bidirectional diaphragm with two possible configurations.

Project Results

The project is performed in two stages. In Stage 1, multi-span bridges having simply supported spans with the proposed ductile diaphragms were investigated to understand their seismic behavior, considering various layouts and implementation strategies. Moreover, a parametric analysis considered the influence of different elements of the structure, such as the geometry of piers (represented by their stiffness), the span mass, and other factors. Two kinds of analyses were conducted in order to determine the level of complexity required to define the design rules. They are modal analysis and nonlinear time history analysis (NL-THA). This was done for two different layouts of BRBs: one layout with BRBs connecting the end of the span to the adjacent bent cap or abutment, as shown in Figure 2 (shown schematically, as, in reality, BRBs will be hidden between girders), and a second layout with BRBs connecting adjacent spans to each other. After understanding which is the ideal configuration and under what circumstances, BRBs were designed for the selected layout using NL-THA to reach the optimal performance of uniform ductility in BRBs along the bridge.

Based on results from this optimal design, a design procedure simple enough to achieve adequate seismic performance was proposed. The design procedure results were assessed by subjecting example bridges (regular and irregular) to suites of ground motions, using NL-THA. The analysis allowed the research team to investigate the impact of the simple design on global behavior, as well as to understand the magnitude of the local demands and the magnitude of hysteretic displacements that the BRBs will have to accommodate. A significant part of the project was invested in Stage 1 research because it is of extreme importance to understand adequately how different configurations of BRBs along the bridge can help to dissipate the seismic energy proportionally across all BRBs and in such way that the substructure and the superstructure remain elastic. Finally, the proposed design procedure and results from nonlinear time history analysis were used to design the 1/2.5 scale specimen to be tested in the second stage.

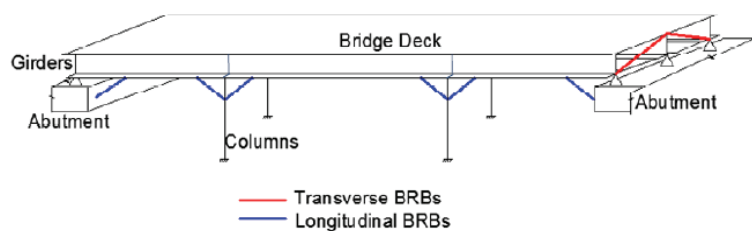

Figure 2

Illustration of a tentative study configuration.

During the second stage (Stage 2), specimens designed in Stage 1 will be subjected to shake table testing. Shake table testing is equivalent to field testing, with the advantage that specimens can be excited by ground motions immediately instead of waiting for severe ground motions to validate the design in the field. The specimen will be one part of a 5 span bridge and it will represent one span with BRBs connected to the abutment and the pier next to it. The main purpose of these tests will be to experimentally validate proposed connection details when subjected to the 3-D displacement histories (compared with the axis of the BRBs) that will result from bidirectional ground motions and the fact that the connections must accommodate inclined BRB layouts. Connections will represent the details applicable for a new construction as well as for retrofitting. Tests will include a qualification hysteretic test protocol (adapted to 3-D), as well as earthquake displacement histories (obtained from Stage 1), and combinations of earthquake and thermal excitations. The test protocols will be repeated on each specimen until failure, to establish their ultimate hysteretic capacity. The validation from experiments will provide the final piece needed to implement the proposed design procedure.

Product Pay-Off Potential

The potential of the project is achieving resilience in ordinary multi-span bridges by using inexpensive BRBs. In contrast with the large seismic displacements that must be accommodated by special expansion joints when using base isolation solutions, the proposed concept results in small displacements that can be accommodated by regular expansion joints. Another advantage of the concept is its simplicity, which makes it an attractive solution for seismic design for all seismic regions and applicable to routine designs, avoiding expensive peer reviews. The way that BRBs are to be located along a bridge also makes them easy to repair, avoiding closure of the bridge in case of needed substitution after an earthquake. Finally, considering the simplicity of the concept, it also makes for an economical and rapid scheme for bridge retrofit.

Product Transfer

The main objective is twofold: to validate the seismic behavior of the bidirectional ductile diaphragm by testing connections subjected to 3-D excitations and to develop a simple design procedure with examples that could be used as guidelines to apply in different bridge projects. The second part of the objective is the product transfer, that is, developing this proposed design procedure in language to be implemented in bridge design specifications.

A PORTABLE SINGLE LANE TRAFFIC COUNTING DEVICE

NCHRP-IDEA Project 216

Terry Lee [Tel.: (603) 369-2785, Email: leetronvision@gmail.com]
Leetron Vision, Concord, New Hampshire

IDEA Concept and Product

State DOT workers are expected to carry out outdated tasks that endanger their safety. The current system of utilizing road tubes requires workers to kneel in the middle of the road, subjecting them to harm. (Figure 1). Transportation agencies have yet to devise a system that can replace road tubes without sacrificing quality and cost. This current innovation, a prototype, aims to create a product that is not only cost-effective but also safe for workers.

For years, transportation agencies have been looking for new, non-intrusive ways to monitor traffic. Various industries and technologies have answered the call for non-intrusive traffic counters by developing products that utilize Doppler microwave detection, acoustic detection, passive infrared, video-based offline processing, and video-based online processing. While there has been a steady increase of the use of new products in higher speed and heavily trafficked areas where road tubes are less practical, the vast majority of the traffic counts still rely on road tubes. The data quality and cost remain the two main factors preventing more extensive use of the newer technologies.

Prior to this project, Leetron Vision's research team had developed a portable real-time video-based multi-lane traffic counting unit, called AI (artificial intelligence) Count 100. The success of AI Count 100 provides the confidence and experience to take this technology to the next level. While searching for alternatives to road tubes, the team discovered that by concentrating on measuring a single lane, comparable data collection quality at competitive costs could be achieved. While this single-lane system will not work on roads with more than two lanes in one direction, an internal study indicates that it will be suitable to replace most tube counts currently in use. This project will focus on expanding this finding to develop a single-lane system that offers a cost-effective alternative to tube count.



Figure 1

Road tube installation.

Project Results

During product development, new findings led to adjustments of the project's goal. These findings showed that not only can this product match the current quality of count and classification of traditional counting systems but it can also overcome limitations other systems have faced and provide more accurate data. Limitations of traditional counting systems include:

- Issues in accurately reporting counts when traffic speed changes, including traffic congestion and stop-and-go conditions.
- Problems in counting vehicles with trailers at various lengths and wheel counts.
- Inability to remove occlusions
- Inability to detect trucks with wheels up or down.
- Inability to identify dual-wheel for pickup trucks.
- Difficulty in separating buses from trucks consistently.
- Ineffective on higher speed road ways.

Based on the internal evaluation results from the prototype unit (see Figure 2), typical count accuracy of the device is at 99% level, and FHWA 13 vehicle category classification results are at 98% level. While the prototype demonstrates the ability to overcome the listed limitations above, more extensive evaluation is under way to evaluate the effectiveness.



Figure 2

Prototype unit.

Product Pay-Off Potential

Safety: All states take safety very seriously and want an alternative solution to the road tube to remove their workers from the risks of intrusive data collection. This innovation will no longer require the need to put workers in harm's way.

Labor-intensive work can introduce repetitive motion injury: The constant kneeling, repetitive motion, and force at which a worker is required to hammer causes stress on joints and muscles, which may lead to later joint pain and muscle-related injuries. Due to this risk, it is becoming more difficult for states to find workers willing to perform this task. With this innovation, there is no labor-intensive work involved.

Productivity gain: Installation time will be shortened dramatically. Rather than the typical setup time of 15 to 20 minutes, it will only take a few minutes to mount and turn the device on. Based on the feedback from current workers who have utilized both systems, productivity has increased a reported 25% to 35%.

Material costs: For each data collection, the estimated additional material cost of \$25 for nails, tape, and tubes can be eliminated with this product.

Count and classification accuracy: Though the cost of this device is not as low as anticipated, the accuracy of counting and classification it provides outweighs the additional cost.

Product Transfer

Once the production unit is ready, Leetron will promote and sell the product through existing sales channels. New York State DOT is committed to pre-order units, and many other vendors are committed to evaluate this new device. Based on projections from the manager of the Traffic Monitoring Division, FHWA, this device should have sales projected in the thousands.

A REAL-TIME, PROACTIVE INTERSECTION SAFETY MONITORING AND VISUALIZATION SYSTEM BASED ON RADAR SENSOR DATA

NCHRP-IDEA Project 217

Zhixia (Richard) Li [Tel.: (502) 852-2307, Fax: (502) 852-8851, Email: richard.li@louisville]
University of Louisville, Louisville, Kentucky

IDEA Concept and Product

Enabled by placing temporary or permanent radar sensors near the intersection, which can track the trajectories of all vehicles and pedestrians using the intersection, the concept of this project is to develop an intersection proactive safety visualization (IPSV) system to monitor intersection safety in real time and visualize the spatial distribution, frequency, severity, and types of all near misses that have happened at the intersection. Traffic engineers can use this visualization approach to identify the potential intersection safety problems. This innovation addresses the U.S. DOT's high priority need by targeting the areas of highway safety and vulnerable users such as pedestrians. Using this approach, the traffic conflicts and their magnitudes that will be visualized in the proposed system are actually true representations of the intersection safety issues, because the traffic conflicts do not miss any safety problems or near misses that have happened at or near the intersection, even including all types of traffic conflicts. Figure 1 illustrates six different types of traffic conflicts that will be identified by IPSV.

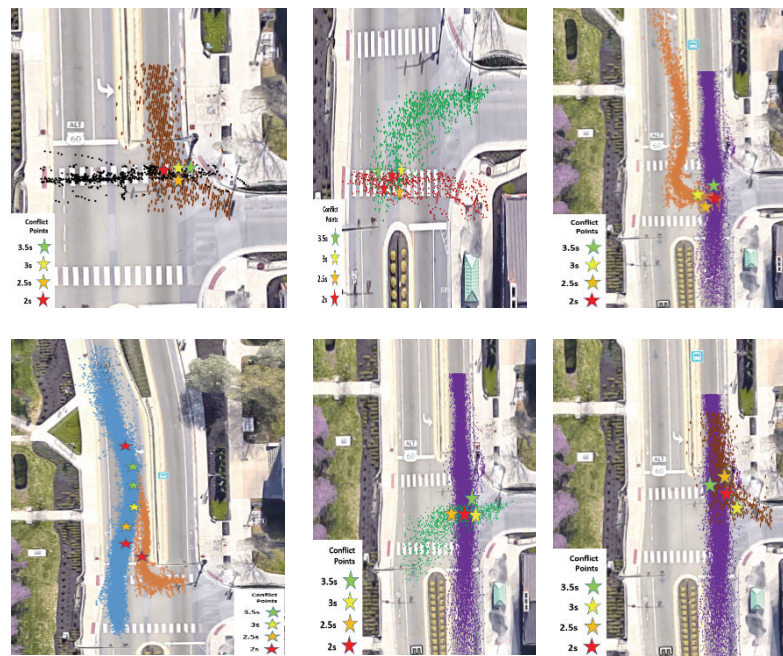

Figure 1

Conceptual illustration of the proposed process: identification and visualization of traffic conflicts by types.

Project Results

The project is being performed in two stages. Work in the completed Stage 1 focused on developing the IPSV algorithm from automated collection of radar sensor data. Sample trajectory data was collected from radar sensors installed at an intersection in Louisville, Kentucky. An automated data preprocessing algorithm was developed and implemented in the IPSV system. The algorithm integrates trajectory data from four radar sensors at the intersection. A noise reduction module was developed in the algorithm to remove trajectory noise from the analysis. Also, a coordinate transformation and trajectory data integration module was implemented in the algorithm to combine trajectory data from multiple radar sensors in the same reference coordinate system. A second algorithm that automatically classified different traffic and pedestrian movements was developed to enable automatic computing of time to different types of collision. The algorithm also identified conflicting traffic/pedestrian movements. Based on predefined thresholds of time to collision (TTC), traffic conflicts of different types were automatically identified and their severities measured. Figure 2 illustrates a field study in Louisville to prove the concept of the IPSV development in Stage 1, in which rear-end conflicts and crossing type conflicts that include right-angle, vehicle-pedestrian, and left-turn types were tentatively identified.

Work is under way in Stage 2 that involves improving the IPSV accuracy, developing a user interface to configure IPSV parameters, as well as testing and validating the IPSV at an additional intersection. The IPSV algorithm was updated to improve the TTC accuracy under lane change situations and vehicle-stopping conditions. The algorithm accuracy to overcome relatively distorted data was improved, particularly the accuracy of vehicle lateral positions in the through movement and in the turns. In addition, the automation level of the IPSV algorithm was enhanced by eliminating several manual steps, such as lane centerline delineation and conflict pair configurations. The IPSV will be further tested at an urban unsignalized intersection in Louisville, Kentucky. Trajectory data will be collected along with TTC, traffic conflicts,

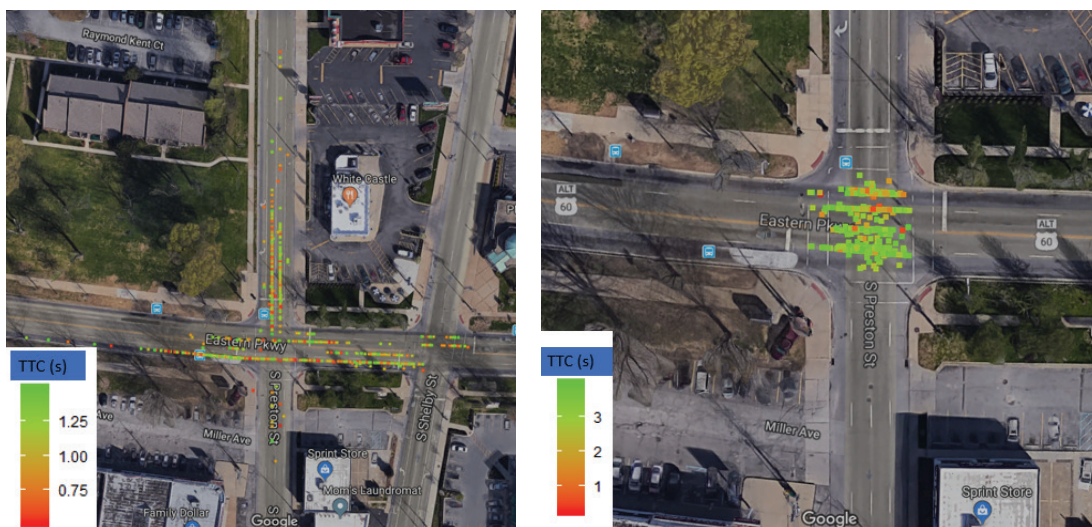

Figure 2

Proof-of-concept field study: identification and visualization of rear-end conflicts and crossing-type conflicts.

and traffic conflict severity data. All functions of IPSV will be tested to make sure they work as intended and validated based on field-collected data. The accuracy of TTC, traffic conflicts, and traffic conflicts severity will be evaluated using trajectory data collected from a video camera. The safety performance accuracy will be compared with the historical crash data to ascertain whether there is a consistent trend.

Product Pay-Off Potential

The most important impact of this innovation is the ability to obtain proactive intersection safety measures. Intersection safety measures need to (1) accurately represent the intersection safety performance, which does not miss any safety issues, including both conflicts/near misses and crashes; (2) are not necessarily obtained at the cost of losing lives and injuring road users, which allows fast adjustment of safety treatment to save lives and economic costs incurred; and (3) enable fast highway safety improvement evaluation using data 1 week before and 1 week after safety treatment is implemented rather than years of crash data.

Product Transfer

This project aims to provide both hardware and software for an IPSV system. Potential customers of this system are state DOTs, the FHWA, and local transportation agencies, including existing customers of the radar providers. Consequently, the market for the proposed system is large and expected to increase with time. The project team is involving a radar manufacturer, a state DOT, and a city traffic engineering department specifically for implementation issues. In addition, the state DOT personnel will provide input from the user's perspective. The University of Louisville's Office of Technology Transfer will assist in patent filing and licensing, as well as provide support for commercialization of the technology.

DEVELOPMENT OF A FAST AND COST-EFFECTIVE ASPHALT MIXTURE FATIGUE TEST SYSTEM

NCHRP-IDEA Project 218

M. Emin Kutay [Tel.: (517) 353-9297, Fax: (517) 432-1827, Email: kutay@msu.edu]
Michigan State University, East Lansing, Michigan

IDEA Concept and Product

The objective of this project is to develop a fast, robust, and cost-effective asphalt mixture fatigue testing system called the three-point bending cylinder (3PBC) test. Traditional fatigue tests are lengthy, cumbersome, and expensive. Extensive material requirements for sample preparation, difficulty in meeting air void targets, large numbers of samples needed for testing, common premature “end failures,” and high equipment costs are some of the challenges encountered when running these tests. The uniqueness of the new setup stems from the fact that the loading mode is in bending (reflective of field conditions) and possesses most advantages of current state-of-the-practice tests (such as the uniaxial fatigue test). The new setup also includes more advantages, such as not requiring a saw to cut the ends of the sample; not requiring gluing operation (and the gluing jig); and the possibility of estimating Poisson’s ratio from the test data. Figure 1a and b shows a 3-D blueprint and an actual photograph of the 3PBC setup.

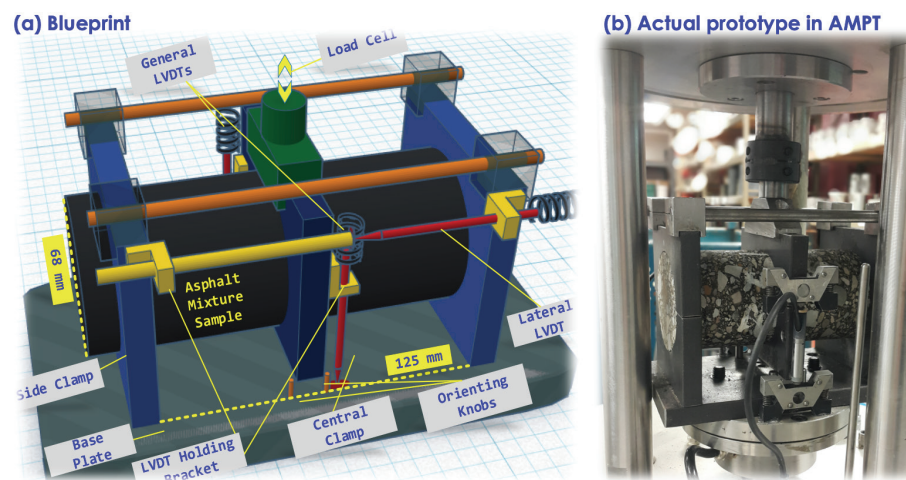

Figure 1

The three-point bending cylinder (3PBC) setup: (a) 3-D blueprint and (b) photograph of the setup within an asphalt mixture performance tester (AMPT).

Project Results

The project started with a focus on the design of the 3PBC test fixture and its enhancement so it can be seamlessly integrated into the asphalt mixture performance tester (AMPT). To date, the 3PBC test fixture has been enhanced, and new ways of mounting the sample into the fixture have been developed to speed up mounting of the sample and reduce the risk of damage to the sample (and to the AMPT). Another subtask focused on the Poisson's ratio that can be obtained from the 3PBC test. The effects of Poisson's ratio on the calculation of the damaged dynamic modulus ($|E^*|_N$) were investigated. Another task of this project was to verify the applicability of Timoshenko-Ehrenfest Beam Theory on different asphalt mixtures. 3-D elastic and viscoelastic finite element (FE) analyses were performed to simulate the 3PBC test by using the exact geometry of the 3PBC setup. Three laboratory-prepared asphalt mixtures were used to complete this task. The results revealed that Timoshenko-Ehrenfest Beam Theory formulations used for the 3PBC system are valid both dynamic modulus ($|E^*|_N$) and Poisson's ratio, and the error is well within the typical sample-to-sample variability of asphalt samples.

In order to facilitate the analysis of 3PBC data using the viscoelastic continuum damage (VECD) theory, a software program was developed. The beta version of the software is called 3PBC-VECD. Once the laboratory dynamic modulus ($|E^*|$) data are entered, the software generates the $|E^*|$ master curve, converts the $|E^*|$ master curve to creep compliance ($E(t)$), and automatically computes the maximum slope (α) of the $\log(E(t))$ - $\log(t)$ graph, which is needed in VECD formulations. The program for each sample automatically generates the VECD damage characteristic curve, that is, C (pseudo stiffness) versus S (damage parameter) curve. Software then calculates number of cycles to failure (N_f) at different temperatures/frequencies for each sample by simulating a perfect strain-controlled fatigue test (using the C versus S curve established earlier). Software automatically fits the traditional fatigue life equation used in MEPDG and generates the "beta" calibration coefficients that can be used in mechanistic-empirical pavement design software.



Figure 2

Poisson's ratio measurement setup in material testing system unit.

One of the tasks of this project was obtaining Poisson's ratio via direct measurement. During uniaxial push-pull fatigue tests, Poisson's ratio (ν) was measured by using a radial linear variable differential transformer (LVDT), which is a chain and loose core LVDT combination, and two axial LVDTs, as shown in Figure 2. The finding from this task was that Poisson's ratio did not significantly change during the fatigue test, although a slight decrease was observed for some mixtures at certain temperatures (e.g., Poisson's ratio was lower at 10°C as compared to 20°C). On average, Poisson's ratio values were in a narrow range between 0.27 and 0.34. Based on the results, an average value of 0.3 for Poisson's ratio was recommended to be used in 3PBC tests if no other information was available. Further experimental studies on different types of asphalt mixtures would be useful to identify factors affecting Poisson's ratio.

Another task of this project was to perform the ruggedness evaluation of the developed 3PBC test system. Ruggedness testing is a key component in developing a standard test method. As part of this task, a ruggedness testing plan was developed. The ruggedness testing plan included (1) identifying the major test factors that may influence the 3PBC test and (2) developing a statistically sound and efficient laboratory experimental design. The ruggedness of the 3PBC test is being evaluated in accordance with the ASTM C1067-20 protocol. Six factors are being investigated as part of the ruggedness test matrix. These factors include air voids, strain level, side clamp tightness, temperature, frequency, and placement of the central clamp/eccentricity. These factors were selected based on the research team's experience in dealing with the 3PBC test fixture and test data.

Preliminary results showed that air voids, clamp tightness, and eccentricity influence how damage grows within the specimen. The reasons for this are as follows:

- Samples with different air voids are compacted to different levels and therefore the damage accumulation mechanisms are expected to be different.
- Clamp tightness affects the main assumption used in the Timoshenko-Ehrenfest beam formulations for the 3PBC test. If the side clamps are not sufficiently tight, the assumption of the beam being perfectly fixed at two ends becomes invalid, and the beam can become a simply supported beam, in which the Timoshenko-Ehrenfest beam formulations are different.
- Eccentricity in the central clamp completely changes the statics of the system and the stresses will be inaccurate.

More detailed analyses will be conducted and reported after all testing has been completed.

Product Pay-Off Potential

The proposed approach possesses great potential to significantly reduce asphalt mixture fatigue cracking test cost and substantially increase the testing speed. The 3PBC testing system and its software will provide a mechanistic, yet practical protocol to evaluate cracking resistance of asphalt mixtures. When implemented successfully, the DOT engineers will have a better tool to assess the asphalt mixtures used in their pavements and perform improved pavement design. This mixture assessment and pavement design improvement. This tool can extend the overall service lives of the road network and, as a result, lower life-cycle costs.

Product Transfer

The project team will develop a process to transfer the research results into practice in a systematic approach. The implementation plan includes (a) production of an effective product that will be easily teachable, doable, accessible in practice and, perhaps most importantly, usable; (b) identification and execution of implementation stages (e.g., presentations at AASHTO Technical Committee meetings and TRB webinars); (c) provision of input for implementation drivers (e.g., provision of assistance in training and coaching of the practitioners); (d) assistance to the implementation team; and (e) collection and processing of product feedback (e.g., user/agency feedback). In short, effective implementation strategies will be adopted for rapid and successful implementation of the 3PBC testing system by the roadway agencies.

A NOVEL DURABLE, HEALABLE, AND CONVENIENTLY REMOVABLE PAVEMENT MARKING MATERIAL SUITABLE FOR BOTH PERMANENT AND TEMPORARY MARKING USES

NCHRP-IDEA Project 219

Long Jiang [Tel.: (701) 213-9512, Fax: (701) 231-8913, Email: long.jiang@ndsu.edu]
North Dakota State University, Fargo, North Dakota

IDEA Concept and Product

The concept of this study is to develop a novel permanent and temporary dual-use pavement marking material using vitrimer chemistry. Vitrimer polymers consist of dynamic covalent bonds as cross-links, which provide the material's desirable properties from thermosets and thermoplastics simultaneously. They are high strength and durability from the thermosets and malleability/self-repairability from the thermoplastics. On the one hand, these properties are expected to render pavement markings a long service life. On the other hand, the vitrimer proposed in this study is also designed to include a functional group that breaks apart under a specific condition, allowing easy removal of the marking from the pavement when necessary. This material characteristic is expected to reduce or eliminate many negative effects of current marking removal techniques (e.g., grinding and sandblasting), including noise, dust, and high-energy consumption. The expected product from this project is a novel vitrimer-based pavement marking material. This new product can be installed on the pavement using existing epoxy marking installation equipment. Marking installation and removal currently cost large amounts of financial, societal, and natural resources. Successful development and industrial adoption of this new material is expected to bring important economic, environmental, and human health benefits to society.

Project Results

Different reagents were used to synthesize five different types of Schiff base diamines (SBDA) as the crosslinkers to cure epoxy resin. All the synthesized crosslinkers contained dynamic covalent bonds [i.e., imine bonds (C = N)] that imparted vitrimer behavior to the cured epoxy marking. The first two SBDA crosslinkers were found to be not suitable for pavement marking use due to their drawbacks, including a tendency to solidify during storage and relatively low reactivity in curing epoxy. The third, fourth, and fifth SBDA crosslinkers maintained their liquid state during storage and could successfully cure epoxy.

To overcome the low reactivity of the second IPDA/TPA-based SBDA, the third SBDA used two Jeffamines, EDR-148 and D-230, to synthesize a mixed Jeffamine-based SBDA in one pot. The third SBDA proved to be too water sensitive due to the polyethylene glycol based EDR-148. In the fourth SBDA, Jeffamine EDR-148 was replaced by 1,3-Diaminopropane (DAP) (Figure 1). The fifth SBDA replaced all Jeffamines with DETA to further improve reactivity and decrease water sensitivity.



Figure 1

Synthesis of the fourth SBDA curing agents (left) and the demonstration of their viscosities (right).

The resulting third, fourth, and fifth SBDA were mixed with each other and a commercially available amine, DETA, in different ratios to produce curing agents that allowed for tailorable properties in the resultant epoxy. The amines were mixed with 4-nonylphenol (NP) to increase reactivity and bisphenol A diglycidyl ether (BADGE) to prepolymerize 5.53% of the amine within the curing agent. The curing agent was allowed to cure for at least a day before being heated at 50 °C for 20 minutes and used to cure an epoxy resin. The epoxy resin contains mainly BADGE but also contains trimethylolpropane triacrylate (TMPTA), which the amine also reacts with at a lower temperature. A small amount of NP is also added as well as titanium dioxide (TiO₂) powder, which increases the hardness and causes the final epoxy to appear white.

Material property tests were chosen to verify that the materials met the pavement marking specifications and to compare their vitrimer and selective removability properties. The hardness of the epoxy was tested periodically after mixing the two parts to determine the curing rate. The pavement materials were tested to have a no-tracking condition of under 25 minutes and a Shore D hardness greater than 80 after 72 hours. The abrasion resistance was tested to have a wear index under 80 mg/1000 cycles using a cs-17 abrader disc on a Taber Abrader (ASTM C501). The self-healing was tested by measuring the width of a micro-scale scratch on the surface before and after heating at 50 °C to determine the materials repair ratio. The solution resistance/removability was tested after submerging samples in alkaline, acidic, and DI water solutions and determining the softening based on scratching the coating. An amine mixture of 40% SBDA 3, 40% SBDA 5, and 20% DETA was determined to meet the specifications required of a road marking material while being the formulation that showed the best selective removability and promising self-healing properties (Figure 2).

In the next stage, market information about the marking materials will be gathered. Longer-term, larger-scale highway tests of the new marking material are planned for this project. Minnesota DOT will support marking installation and removal tests at the Minnesota Office of Materials and Road Research testing facility. North Dakota DOT, Fargo district, will be sought for collaboration on public road tests. The results will be used to further refine the formulation of the new marking material.

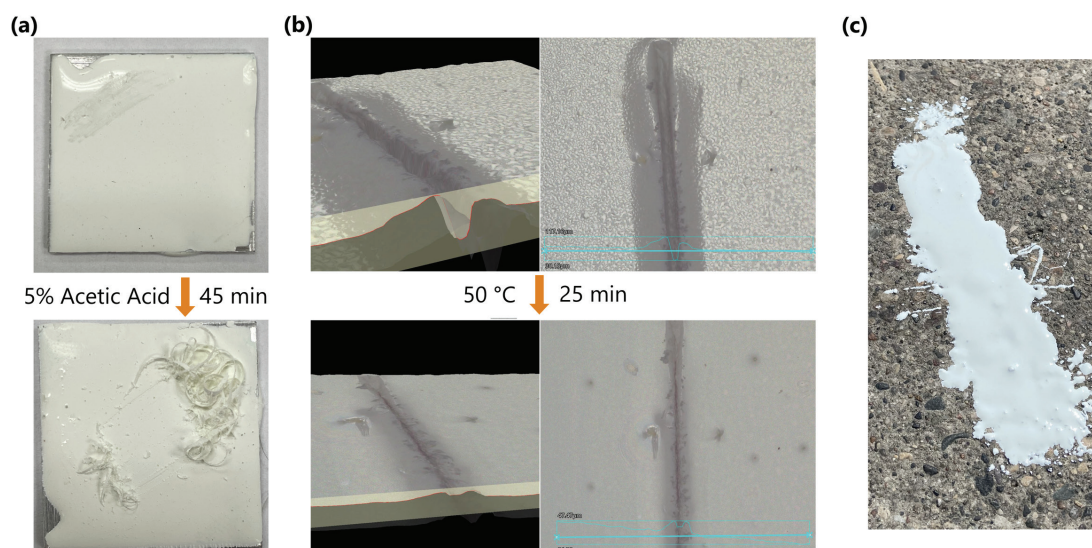

Figure 2

(a) Selective removability under 5% acetic acid for 45 minutes, (b) self-healing at 50 °C for 25 minutes, and (c) the marking material applied to pavement.

Product Pay-Off Potential

Periodic pavement marking installation, maintenance, and removal cost a huge amount of money and resources. Failure to maintain clear pavement markings can lead to significant life and asset losses. The proposed epoxy vitrimer marking material is expected to last longer than current state-of-the-art marking material on the market due to its self-repairing capability. Its removal from the pavement is also expected to be much easier, more cost-effective, and more environmentally friendly. Successful development and widespread use of this innovative marking material is expected to have substantial and positive social, economic, and environmental effects on society.

Product Transfer

The new marking materials can be used in construction, transportation, and airport industries. On a smaller scale, the materials can also be used by facility management offices of corporations and organizations on internal construction/transportation projects. The product will be tested on I-94 through collaboration with the Minnesota Office of Materials and Road Research. North Dakota DOT, Fargo district, will seek to demonstrate the applicability of the marking material during its construction season in summer. Inputs from these agencies and users will be used to further optimize the products. Information about this new product will be disseminated through advisory panel meetings, through conference presentations (e.g., Minnesota DOT and North Dakota DOT annual meetings), and through collaboration with the Upper Great Plains Transportation Institute.

BRIDGE DECK SEALANT MONITOR: THERMAL SEAL CHECK

NCHRP-IDEA Project 220

Paul Fuchs [Tel.: (703) 777-2115, Fax: (703) 737-6381, Email: paul.fuchs@fuchsconsultinginc.com]

Glenn Washer [Tel.: (573) 239-1368, Fax: (703) 737-6381, Email: washerg@missouri.edu]

Fuchs Consulting, Inc., Leesburg, Virginia

IDEA Concept and Product

This project has developed a new nondestructive technology to determine the effectiveness of sealers used for the preservation of bridge decks and other concrete components. The new technology fills a critical gap in the ability of bridge owners to assess the quality of sealers in situ to support data-driven bridge preservation strategies and performance-based decisions. The method is simple to implement with minimal-to-no effect on traffic. The new technology was developed based on an existing platform for advanced time-lapse thermal imaging of subsurface defects (delamination) in concrete. Prior to the development of this technology, there were no available methods for the in situ assessment of deck sealers to determine quality and effectiveness. Bridge owners were forced to rely on periodic reapplication of sealer to attempt to preserve the good condition of bridge decks.

The technology works by measuring thermal changes during water evaporation on concrete using time-lapse thermography. The measurement works by watering the surface of the deck and then monitoring its evaporation using a thermal camera. The measured thermal characteristics of the evaporation show the effectiveness of the sealer in resisting the absorption of water into the concrete. Measurements are made with a ThermalStare IR-UTD instrument, which is a time-lapse thermography measurement system placed on or near a bridge and used to create thermal images of the deck over time. IR-UTD technology is effective for detecting subsurface damage, such as delamination, and was augmented in this research to also assess the quality of deck sealing. Using this technology, both sealer effectiveness and deck deterioration can be assessed simultaneously if desired. The basic concept is illustrated in Figure 1, which shows an IR-UTD system mounted to a bridge parapet for monitoring and applying water on the bridge deck.

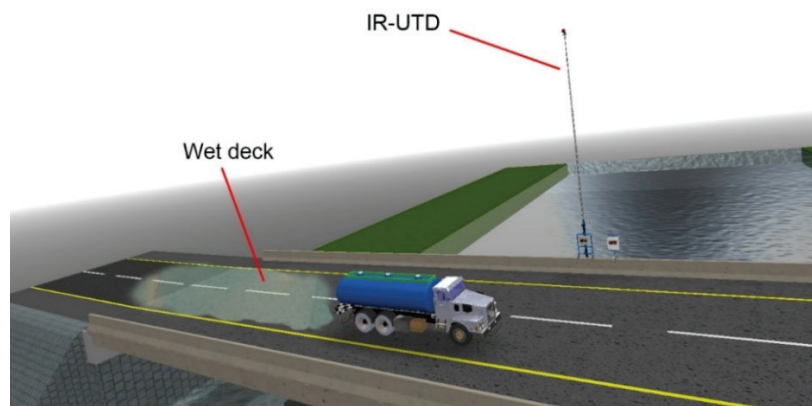

Figure 1

Concept illustration of IR-UTD sealant measurement.

Project Results

This research has created the first method that provides an in situ assessment method for penetrating sealers on bridge decks. The project has demonstrated the ability to measure the presence or absence of sealers on concrete using time-lapse thermography. A practical method has been developed to implement this measurement in the field and has demonstrated the technique on two in-service bridges. An algorithm for automatically processing and analyzing field data taken with an IR-UTD instrument was developed. The initial field tests have shown an accuracy of approximately 90% in correctly identifying sealed or unsealed concrete. The rate of water application was not critical in these measurements, and two different water application methods were examined. Precise quantities and uniform water coating were not necessary. A measurement can be performed on a bridge in under 1 hour. Once wetting has been performed, the bridge can be fully open to traffic during data collection. Figure 2 shows a sealer assessment test being conducted in Missouri.



Figure 2

Measurement of sealer condition on a bridge in Missouri: (left) view from deck; (right) view from measurements system.

Product Pay-Off Potential

This new technology provides a critical tool for bridge owners to assess product performance, allowing owners to compare the effectiveness of different sealer products and verify vendor claims. This tool will assist bridge owners in identifying approved products for use on bridges in their state. This technology can be used to determine the optimal time for reapplication of sealers. Sealers are applied based on a fixed schedule (e.g., 5 years), based on experience, and based on advice from manufacturers. There is currently no technology available for a bridge owner to assess the need for reapplication. This new technology provides that capability.

Product Transfer

State DOTs can implement this IDEA product now by using existing time-lapse thermography technology services that are now commercially available, as the sealer assessment method uses the same measurement equipment. State DOTs can use time-lapse thermography to assess the subsurface condition of concrete and can now use this IDEA product to assess the condition of deck sealers. Measurements can be combined so that in one equipment setup both the sealer and the subsurface condition of the concrete can be measured. If a large-area measurement is not required, then small-area, tripod-mounted measurements can be performed over localized areas.

DEVELOPMENT OF IN SITU CYCLIC BOREHOLE SHEAR SOIL TEST DEVICE

NCHRP-IDEA Project 221

Jeremy C. Ashlock [Tel.: (515) 294-6176, Email: jashlock@iastate.edu]
Iowa State University, Ames, Iowa

IDEA Concept and Product

The goal of this project is to develop a cyclic borehole shear test (CBST) device for measuring static and cyclic properties of soils in situ. The proposed test would enable rapid in situ measurement of soil shear strength properties (friction angle and cohesion), which are required parameters for the safe design of foundations and earth-retaining structures for virtually all transportation infrastructure, including bridges, pavements, railways, wharves, piers, ports, tunnels, and buildings. The unique capability of the device will be its ability to measure shear strength parameters in the soil's natural setting and much faster than present laboratory techniques, which can require several weeks.

By testing the soil in situ, the device will avoid effects of soil sample disturbance, which can have a significant negative influence on laboratory test results. The device capabilities will also allow engineers to measure soil response under cyclic loading, as occurs in earthquakes, and to measure soil residual strengths, which occur at large deformations in landslides. The device will thus improve the safety and efficiency of the nation's surface transportation infrastructure via faster soil parameter measurement and more accurate, safer designs of bridge and pavement foundations and associated earthworks. The potential impact is immense, as the U.S. construction industry is among the world's largest construction industry, with annual expenditures of more than \$1,231 billion.

Project Results

The CBST hardware was refined based on several laboratory and field tests. Specifically, various components of the device were redesigned, fabricated, tested, and verified to solve the problems identified in the preliminary tests. The LabVIEW software control program was also successfully developed, and several feedback control schemes were designed and tested to perform both monotonic and cyclic borehole shear tests. The linkages between the vertical pneumatic cylinder and shear plates were redesigned to incorporate a curved geometry to minimize mechanical interference that could prevent one shear plate from fully contacting the borehole wall (Figure 1a). The CBST device was also modified to accept the same shear plates and pore pressure port used on the standard BST device. A custom 100-ft long, multi-conductor data cable was acquired, and a feedthrough connector was fabricated and mounted on the device. Field tests were performed in Iowa (Figure 1b and c), followed by tests in South Carolina, alongside traditional monotonic borehole shear tests performed by In-Situ Soil Testing, L.C. The field tests revealed issues needing refinement, including greater than normal electrical noise in the sensor signals, and the shear head reaching its vertical stroke limit due to the softness of the residual soils being tested. Device refinements are currently being made to reduce signal noise and extend the usable vertical stroke of the device from 0.4 to 1.0 inches.

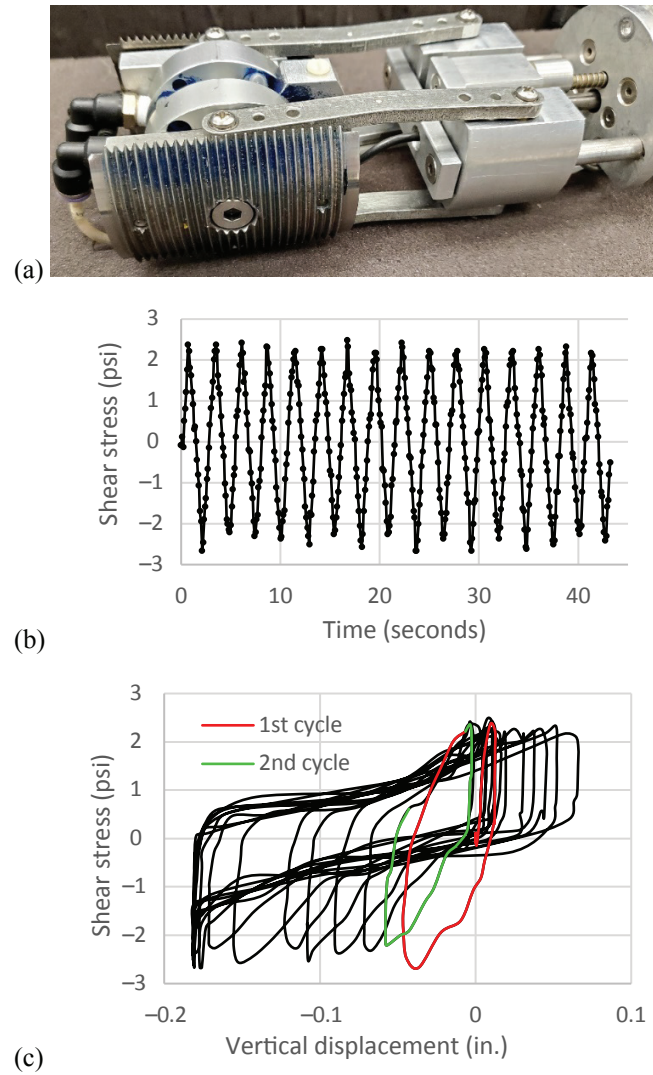

Figure 1

CBST device: (a) CBST shear head with curved linkages and standard borehole shear test unit's shear plates, (b) shear stress versus time from preliminary field tests, and (c) hysteresis loops of shear stress versus vertical displacement from preliminary field tests.

In the remainder of the project, the device capabilities for pore pressure measurement will be tested and refined, and additional field tests will be performed with the Iowa DOT, Terracon Consulting Engineers, In Situ Soil Testing, L.C., and Caltrans. The test results will be compared with other in-situ and laboratory tests to demonstrate the accuracy and capabilities of the new CBST device.

Product Pay-Off Potential

This research project is developing a new in-situ cyclic soil test to provide rapid measurement of soil shear strength properties needed for virtually all foundation designs. The device will also measure the actual physical mechanisms responsible for liquefaction; namely, stress, displacement (related to strain), and pore-water pressure. Such an advancement has the potential to fundamentally transform the empirical techniques currently used in practice for assessment of soil liquefaction resistance into a more mechanistic, physics-based framework. The CBST device would thus significantly advance the safety and sustainability of transportation infrastructure by improving the reliability and accuracy with which foundations are designed and the liquefaction susceptibility of soils is assessed. The economic impact of liquefaction related damage is substantial, with liquefaction-related losses from single earthquakes reaching hundreds of billions of dollars in recent years. Annual earthquake losses in the United States alone are estimated at \$4.4 billion. As all structures are built upon foundations (unless they fly, float, or fall over), the proposed CBST device has the potential for an immense impact on transportation infrastructure and the reduction of earthquake losses.

Product Transfer

The prototype device will be field-tested in cooperation with potential users, including an Iowa Geotechnical Engineering consulting firm that routinely designs bridge foundations, a Virginia in situ testing company that regularly performs a variety of in-situ tests for geotechnical design firms, the Iowa DOT, and Caltrans. In each case, the partnering organizations will provide data from other in-situ tests at the same field sites to enable performance assessment and further development of the CBST device. The final report will include guidance on using the in-situ CBST device and plans for implementation by DOTs.

MIXED REALITY ASSISTED INFRASTRUCTURE INSPECTIONS

NCHRP-IDEA Project 222

F. Necati Catbas [Tel.: (407) 823-2841; E-mail: catbas@ucf.edu]

Joseph J. LaViola, Jr. [Tel.: (407) 823-1047; Email: Joseph.LaviolaII@ucf.edu]

Enes Karaaslan [Tel.: (321) 975-9775; E-mail: enes.karaaslan@ucf.edu]

Mahta Zakaria [Tel.: (470) 767-2199; Email: mahta.zakaria@knights.ucf.edu]

University of Central Florida, Orlando, Florida

IDEA Concept and Product

This IDEA concept of mixed reality (MR) assisted infrastructure inspections explores the state-of-the-art methods and algorithms from interdisciplinary practices. Machine learning is vastly implemented for the robust detection of cracks and spalls on infrastructure surfaces, whereas the human-computer interaction concepts are used to improve the quantified assessment of infrastructure by benefiting from the professional judgment of the human inspector. MR is an ideal platform to maintain this interaction between artificial intelligence (AI) and humans, since it augments virtual information onto the real environment and allows the user to alter the information in real time. In this system, the human-centered AI interacts with the inspector instead of completely replacing the human involvement during the inspection (Figure 1). When developed and implemented, the system will lead to quantified assessment and reduced labor time while ensuring human-verified results.



Figure 1

Illustration of the IDEA concept of mixed reality.

Project Results

A functional, real-time machine learning system that can be ideally deployed in mixed reality devices and headsets and used by inspectors during their routine concrete infrastructure inspection is being investigated in this project. The deep learning models to be employed in the AI system can localize a concrete defect in real-time and further analyze it by performing pixel-wise segmentation while running on a mobile device architecture. A sufficiently large database of concrete defect images was gathered from various sources, including publicly available crack and spalling data sets, real-world images taken during bridge inspections, and public images from internet search results. A large portion of these images were annotated for classification, and the remaining portion is for localization and segmentation. For defect localization, state-of-the-art object detection models with high computational speed, including SSD-MobileNetV2, SSDlite-MobileNetV3, FasterRCNN-ResNet50, SSD-MobileDet, and EfficientDet-D0, YoloV4tiny, and YOLOV5 were compared for inference speed (ms), memory footprint, and mean precision accuracy (mAP). The YOLOV5 model yielded the best optimal performance, with higher accuracy and significantly higher speed than any other CNN model.

Figure 2 shows a comparison of YOLOV5 model results with those of the EfficientDet-D0 model. As can be seen, the EfficientDet-D0 model failed to locate spalling on a concrete

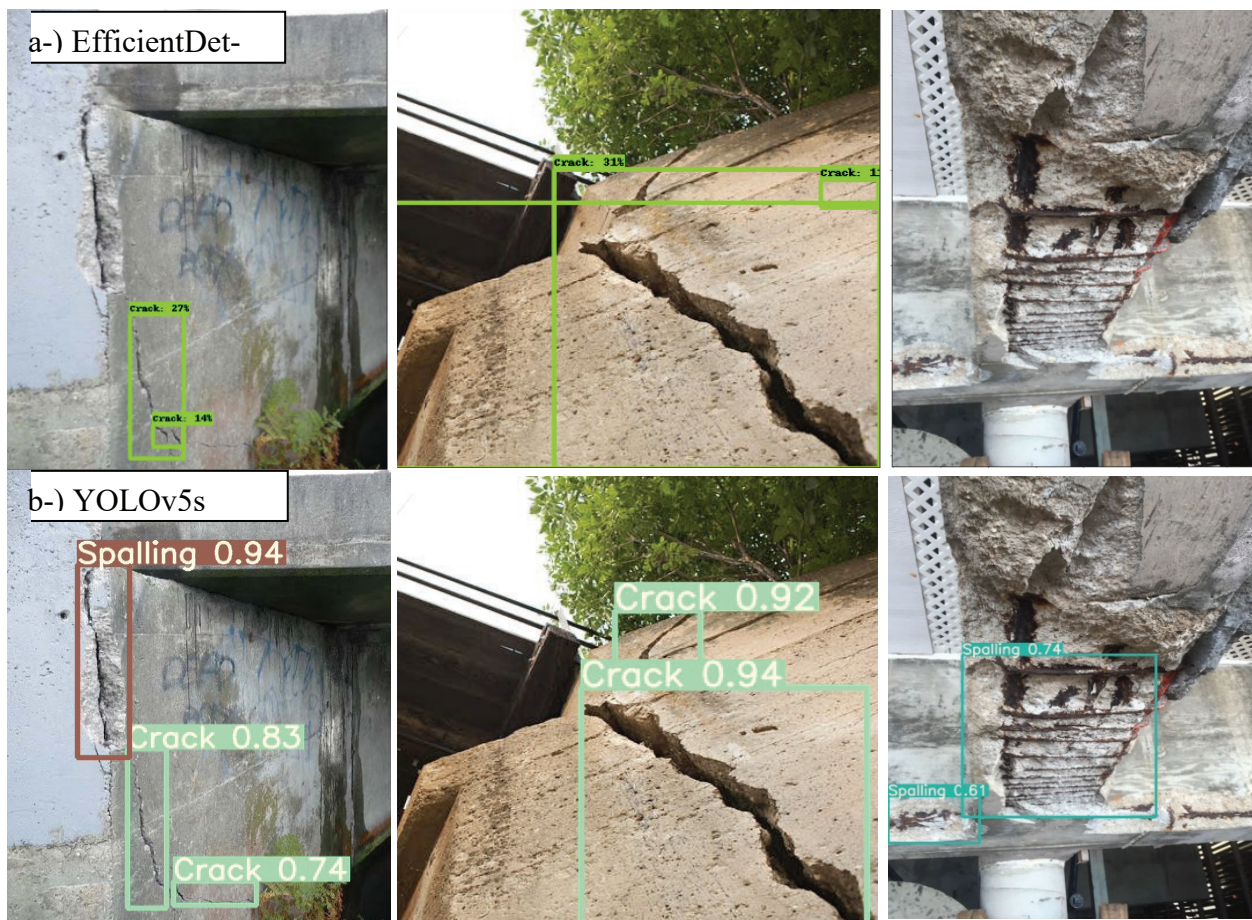

Figure 2

Comparison of damage localization models on real-world images.

structure. The model trainings were continued for quantification of the localized defects by evaluating different pixel-wise segmentation model architectures, including UNet, SegNet, SegCaps, and DeepLabv3, PSPNet, Linknet, and FPN. Each model was trained with three different backbones: efficientnetb0, Densenet, and Inception v3. Figure 3 shows the results for defect quantification models with the Efficientnetb0 backbone. The models were evaluated and compared based on their accuracy, inference speed, and memory footprint. It was shown that while UNet provides the most accurate model, it is not suitable for real-time defect localization because it has a low inference speed. PSPNet, on the other hand, performs with high speed and has good accuracy. To improve the accuracy of PSPNet, a semi-supervised approach was used to generate more labeled data and improve the model's accuracy. UNet was used to generate the additional masks for unlabeled data. After successful training of both defect localization and quantification models, both architectures were quantized and converted to ONNX format, which is compatible with the MR platform, Hololens 2. After a successful deployment of the AI system into the MR platform, a framework for the human-computer interaction will be developed to facilitate a functional collaboration between humans and the AI during the inspection. The overall system is described in Figure 2.

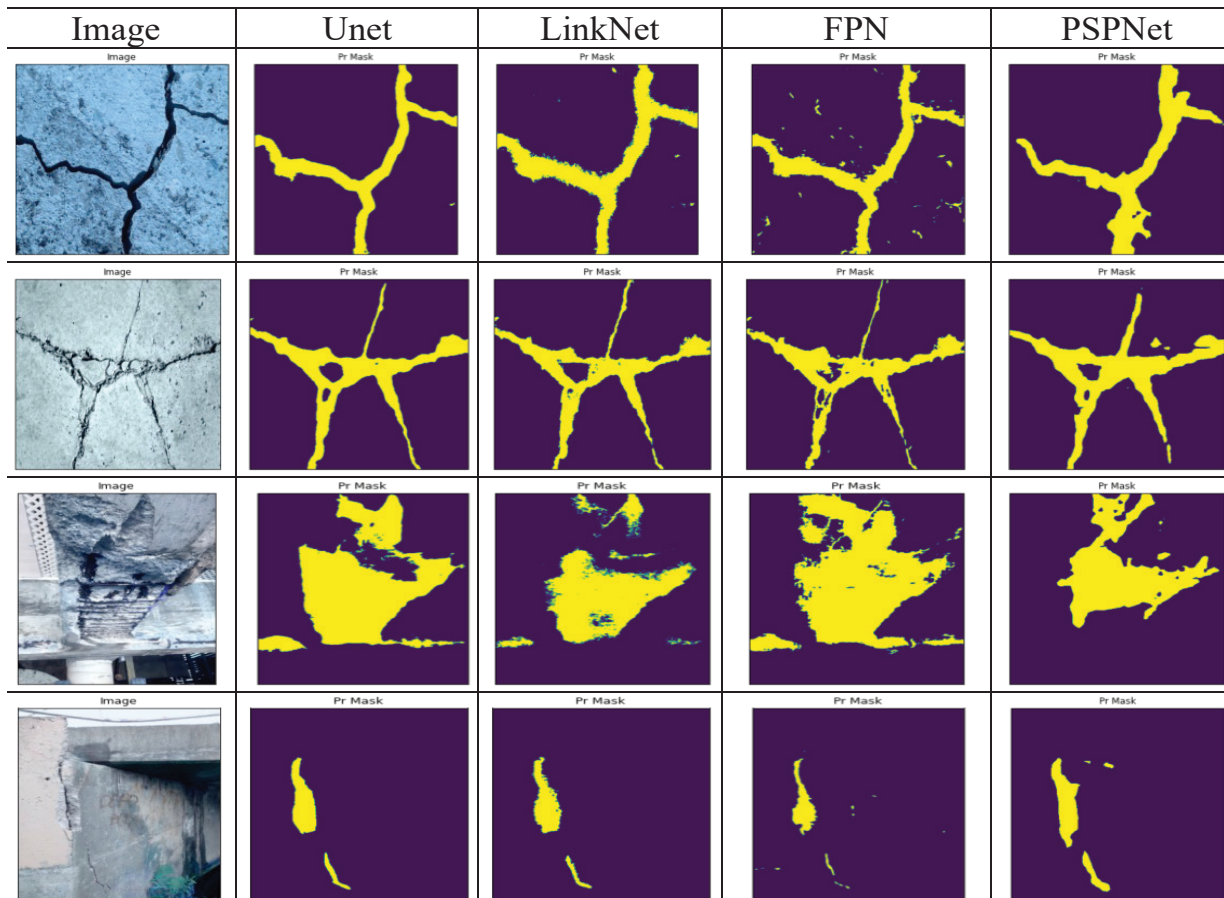

Figure 3

Evaluation results of the selected defect quantification models with the Efficientnetb0 backbone.

Product Pay-Off Potential

Conventional methods for visual assessment of infrastructures have certain limitations such as subjectivity of the collected data, long inspection times, and high costs of labor. Although some new technologies (i.e., robotic techniques) that are currently in practice can collect objective, quantified data, the inspector's own expertise is still critical in many instances. Yet these technologies are designed to replace human expertise or are ineffective in terms of saving time and labor. The product of this project, on the other hand, aims to accelerate certain tasks of the inspector such as detection, measurement, and assessment of defects through AI automation, with easy accessibility to defect locations. The proposed technology offers the following significant contributions to infrastructure inspection, maintenance, and management practices of transportation authorities:

- Enhanced data collection and quantified assessment during visual inspections;
- Faster inspection by performing automatic measurement of defects and reporting;
- Improved reliability of the system, since the AI framework continuously learns from the adjustments made by the inspector and improves itself over time; and
- Easy integration of inspection results to infrastructure management systems.

Product Transfer

In the United States, most departments of transportation (DOTs) spend 50% to 80% of their budgets for maintenance, rehabilitation, and replacement of concrete bridges. DOTs are expected to be long-term customers due to many direct benefits of our technology, such as cost savings on inspection and maintenance decisions of concrete bridges. As part of the National Science Foundation's Innovation Corps (I-CorpsTM)¹ program conducted by the principal investigator and his team, it was found that each segment of the customers engaging in bridge inspection and maintenance has similar "pains": (1) subjectivity of inspection and decision making; (2) traffic control/lane closure for inspection; and (3) safety of inspectors and drivers. The market opportunity was validated through customer discovery interviews with decision makers.

FATIGUE CRACK INSPECTION USING COMPUTER VISION AND AUGMENTED REALITY

NCHRP-IDEA Project 223

Jian Li [Tel.: (785) 864-6850, Fax: (785) 864-5631, Email: jianli@ku.edu]
The University of Kansas, Lawrence, Kansas

IDEA Concept and Product

This project will develop a novel fatigue crack inspection technique by integrating computer-vision-based motion tracking and augmented reality (AR) to enable bridge inspectors to accurately detect, track, and document fatigue cracks in the field in a cost-effective and safe manner. Human visual inspection is currently the de facto approach for fatigue crack detection. However, due to human limitations and the complex nature of bridge structures, fatigue crack inspections are time consuming, labor intensive, and lack reliability. To overcome the challenges, as an entirely new concept, we propose to integrate computer-vision-based motion tracking and AR techniques to empower bridge inspectors to perform robust fatigue crack detection, characterization, tracking, and documentation in the field. First, our computer vision algorithm differs from prior ones in that it does not rely on edge features of images—a major advance in terms of accuracy and usability for fatigue crack detection. Instead, it is based on recording a short video of the structure under fatigue loading, tracking the surface motion of the structure through the proposed computer vision algorithm, and analyzing the surface motion pattern to reveal the ‘breathing’ of fatigue cracks. In addition, crack width can be quantified with sub-millimeter accuracy using the tracked surface motion. Second, to overcome the limitation of the technique in the field for the inspectors, this research will integrate computer vision with AR, so the inspector can see the crack information such as the crack geometry, realized via holograms overlaid on top of the bridge surface. The wearable AR device will greatly increase bridge inspectors’ ability to perform accurate and reliable on-site inspection in a human-centered manner. Moreover, inspectors will be able to interactively manage inspection results and compare with historic data for efficient decision-making. Figure 1 illustrates the proposed framework.

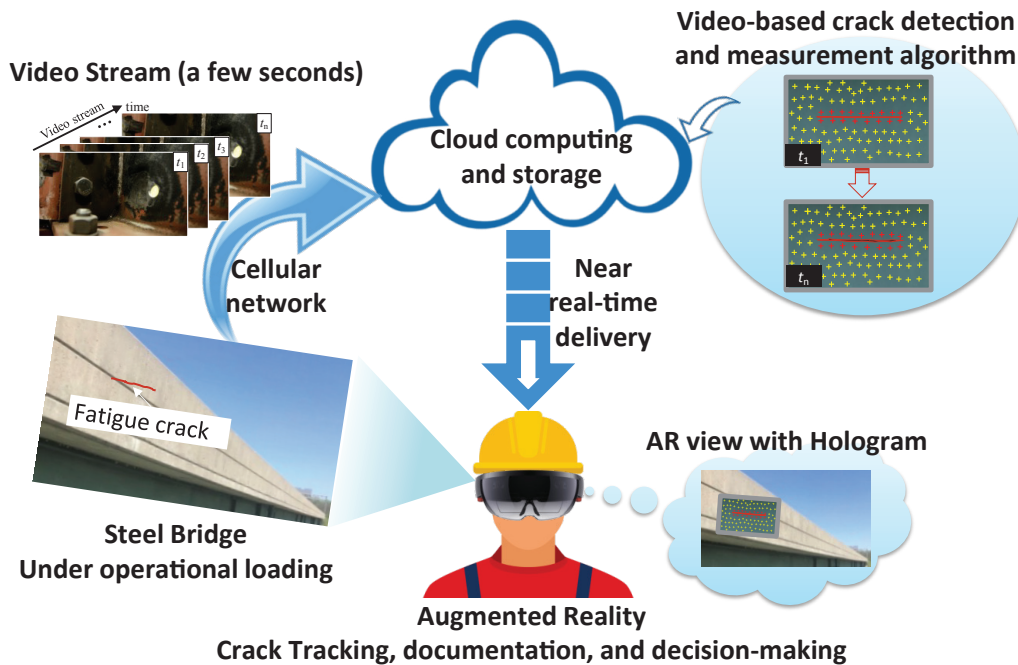

Figure 1

Conceptual illustration of the proposed fatigue crack inspection method using computer vision and augmented reality.

Project Results

The project is currently in its first stage, focusing on: 1) developing the camera motion compensation algorithm, 2) integrating the algorithm with crack detection; 3) optimization for near real-time processing, 4) developing grounding software for “Crack-inspector Holographic Interface”, 5) holographic programming and communication, and 6) holographic anchoring and surface deployment. A robust camera motion compensation algorithm based on optical flow has been developed for videos of planar scenes. The method has been successfully tested on videos taken for a Compact, C(T), specimen recorded using a Microsoft HoloLens 2 device, as illustrated in Figure 2.

In the meantime, the grounding software for holographic interface of crack inspection has been created using Unity and Visual Studio software. The communication protocol between the HoloLens, the cloud database, and the crack detection algorithm has been established. Next step will be focused on further improving the automatic workflow of the communication protocol and developing camera motion compensation methods for videos with 3D scenes. The stage two of the project will be focused on laboratory validations and field deployment of the developed technology.

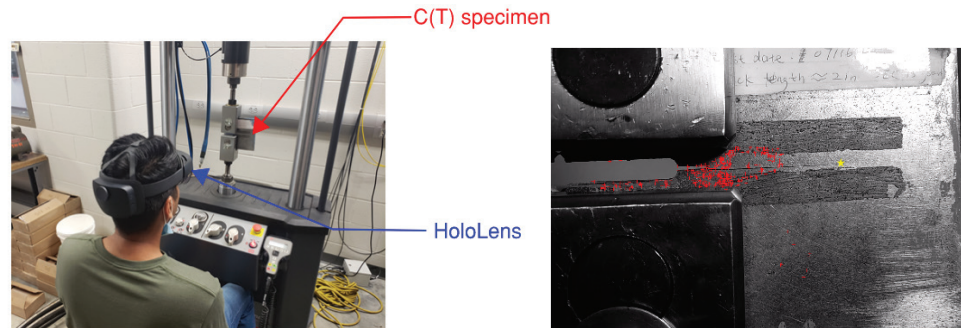

Figure 2

Left: Video capturing using a Microsoft HoloLens 2; Right: Crack detection result of the compact, C(T), specimen using the stabilized HoloLens video

Product Pay-Off Potential

The proposed fatigue crack inspection framework will significantly improve the ability of bridge inspectors to accurately detect, track, and document fatigue cracks in a cost-effective, and safe manner, and prevent costly repairs and catastrophic failures in the large, aging bridge inventory across the U.S. The noncontact nature of the computer-vision method along with the human-centered AR platform enables efficient yet detailed surveying of a large number of bridge details in a timely manner. Major cost savings can be achieved by reducing inspection time, avoiding bridge closures and the need for expensive NDT devices. Most importantly, the new video-based technique overcomes a major limitation of traditional methods that rely on edge detection. With this new technology, inspectors will be able to detect cracks more reliably than with current methodologies, and do so in a manner such that implementation can be broadly scaled.

Product Transfer

The main users of this proposed technique include State Departments of Transportation (DOT), county engineers, and structural inspection companies. To transfer this technique to practice, the research team will collaborate with two government agencies, the Kansas DOT (KDOT) and the Los Alamos County (LAC) in New Mexico, and two respected engineering firms who regularly perform bridge inspections, HNTB and Collins Engineers. The team will engage with the partners in terms of receiving feedback during the development of this technology and field implementations. In addition, the research team has discussed this technology with TRB committee on Structural Health Monitoring and many other DOTs across the country, and will continue to engage with these groups as new advancements are made from this project.

DEVELOPMENT OF AN IDEAL CRACKING TEST FOR ASPHALT MIX DESIGN, QUALITY CONTROL, AND QUALITY ASSURANCE

NCHRP-IDEA Project 224

Fujie Zhou [Tel: (979) 317-2325, Email: f-zhou@tti.tamu.edu]

Texas A&M Transportation Institute/Texas A&M University, Bryan, Texas

IDEA Concept and Product

Cracking and rutting are two major failure modes of asphalt pavements in the United States, and billions of dollars of taxpayers' money is spent in maintaining the roads annually. Producing high quality mixes is critical to avoid cracking or rutting failures through testing the mixes during production. However, neither cracking nor rutting tests are performed at plants to evaluate asphalt mix cracking or rutting resistance during mix production and then to eliminate cracking or rutting prone mixes from being paved on the roads. This is because the current state-of-the-practice testing is neither efficient nor effective to ensure production quality in a timely manner. The concept of this study is to develop an **Automated and Rapid Conditioning and Testing** (Auto-RCT) device to evaluate asphalt mix cracking and rutting resistance in the laboratory or at contractors' plants. It is expected that this project would deliver an Auto-RCT to be used for mix design, quality control, and quality assurance (QC/QA), which every highway agency and asphalt contractor are looking for.

Project Results and Planned Investigation

The project is being carried out in two stages of research. Work in Stage 1 focuses on developing the Auto-RCT device (Figure 1) and validating it through laboratory trials. The device has five critical units: (1) *Rapid specimen cooling/conditioning unit* that cools the hot specimens rapidly and conditions the specimens to different test temperatures required for cracking and rutting tests, respectively; (2) *Automation arm unit* to perform all necessary operations (such as picking up and setting up each well-conditioned specimen to the test fixture and then performing either a cracking or rutting test); (3) *Automated inter-changing unit between cracking and rutting tests*, where cracking and rutting tests are automatically switched without human involvement; (4) *Intelligent data processing and reporting unit*, under which all the processed test results including the pass/fail comparison are automatically sent to the quality control center and state agency QA personnel as needed; and (5) *Automated specimen disposal unit*, where the automation arm automatically disposes the tested specimens. A prototype is being designed and built. The research team has completed the testing of the rapid specimen cooling unit. As shown in Figure 1, a hot specimen (at 70°C) can be cooled down to the room temperature (25°C) within 16 minutes, which is very efficient.

Furthermore, the automated specimen conditioning unit was designed (Figure 2). A robotic arm and associated grippers for performing all necessary operations were procured, along with components for constructing the automated specimen conditioning unit. The research team will continue to design and build other units. After constructing the complete prototype device, a systematic evaluation will be performed using a minimum of 10 different asphalt mixes with varying asphalt binder types/grades, aggregate types/gradations, and recycled materials.

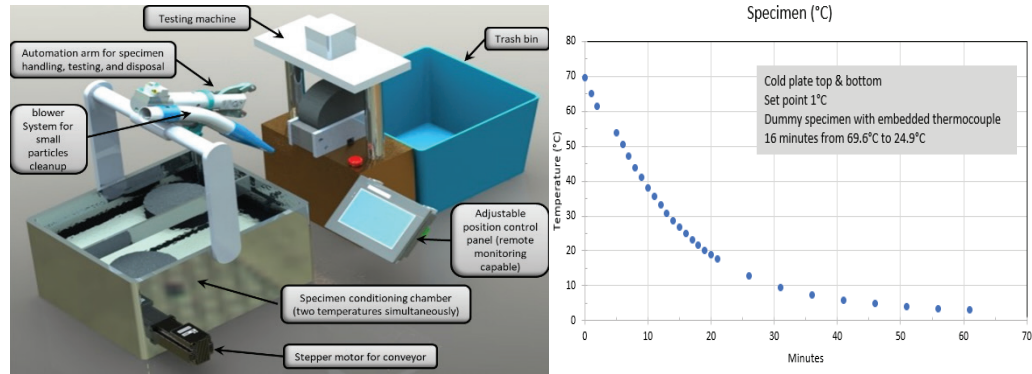

Figure 1

Concept of the AUTO-RCT device.

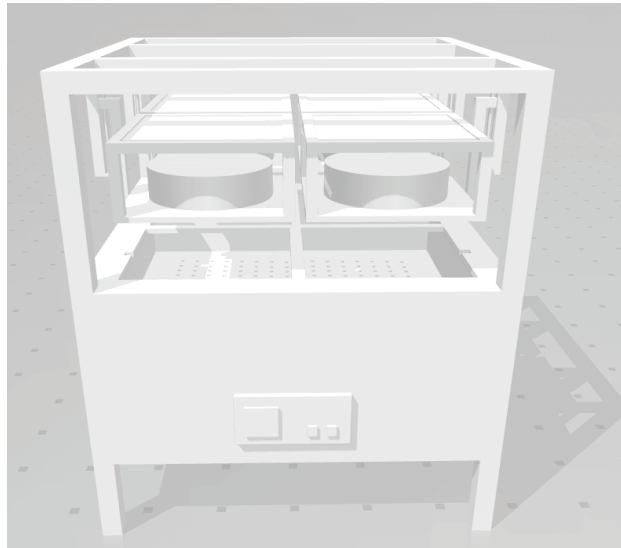

Figure 2

Concept of the conditioning unit.

The next phase, Stage 2, will focus on developing a draft test procedure, standardizing hardware and software of the device, and establishing an implementation plan. Final drawings of the device will be completed, and data analysis algorithms will be developed to calculate cracking and rutting parameters. An implementation plan will be developed at the end through working with different state agencies, such as the Texas DOT, the Oklahoma DOT, the Virginia DOT, and the Maine DOT.

Product Pay-Off Potential

Every year, around 360 million tons of asphalt mixes are designed, produced, and placed in the United States, and the associated cost is more than \$20 billion. Given this incredibly large amount of taxpayers' money and the well-established unsatisfactory infrastructure (roads) system, the results of the proposed research can be used for producing durable asphalt mixes lasting 20% longer than existing mixes through directly evaluating and eliminating asphalt mixes with poor cracking or rutting resistance with the Auto-RCT. The estimated savings will be significant and will also reduce the maintenance costs, associated traffic delays, and travel times of every road user.

Product Transfer

In the final stage of this project, the research team will partner with different equipment manufacturers to develop a draft AASHTO test procedure and all necessary hardware (standalone test machine and/or fixtures) and software tools for implementing the Auto-RCT, which will allow the test standards, hardware and/or fixtures, and software tools to be commercially available upon completion of the project. Furthermore, an implementation plan will be developed in coordinating with different state agencies. Additionally, the research products will also be transferred to a broader audience through (1) presentations at TRB annual meetings; (2) a project advisory panel made up of researchers, state agencies, design engineers, construction contractors, and educators; and (3) refereed journal publications.

AN AUTOMATED SYSTEM FOR LARGE-SCALE INTERSECTION MARKING DATA COLLECTION AND CONDITION ASSESSMENT

NCHRP-IDEA Project 225

Kun Xie [Tel.: (757) 683-4304, Email: kxie@odu.edu]

Hong Yang [Tel.: (757) 683-4529, Email: hyang@odu.edu]
Old Dominion University, Norfolk, Virginia

Hongkai Yu [Tel.: (216) 687-3869, Email: h.yu19@csuohio.edu]
Cleveland State University, Cleveland, Ohio

IDEA Concept and Product

This project aims to develop an automated system for large-scale intersection marking data collection and condition assessment. Figure 1 illustrates the conceptual design of the system. The proposed system focuses on two types of markings at intersections – lane-use arrows and crosswalks – while it has the flexibility to be extended to cover other road markings as well. The proposed system economically utilizes roadway GIS data and aerial images as inputs, which are commonly available from state DOTs or open sources. The GIS data are first used to identify intersections in the target area and to auto-extract the corresponding intersection aerial images. The innovative use of GIS data enables fast indexing and identification of intersections and accelerates the process of aerial image data extraction, making the proposed approach truly scalable and computationally efficient. The extracted intersection image data are being used to train novel computer vision models for detection, characterization, and condition assessment of intersection markings. The final system will be refined to produce customized data output to meet the requirements of state DOTs before being integrated into the existing roadway inventories.

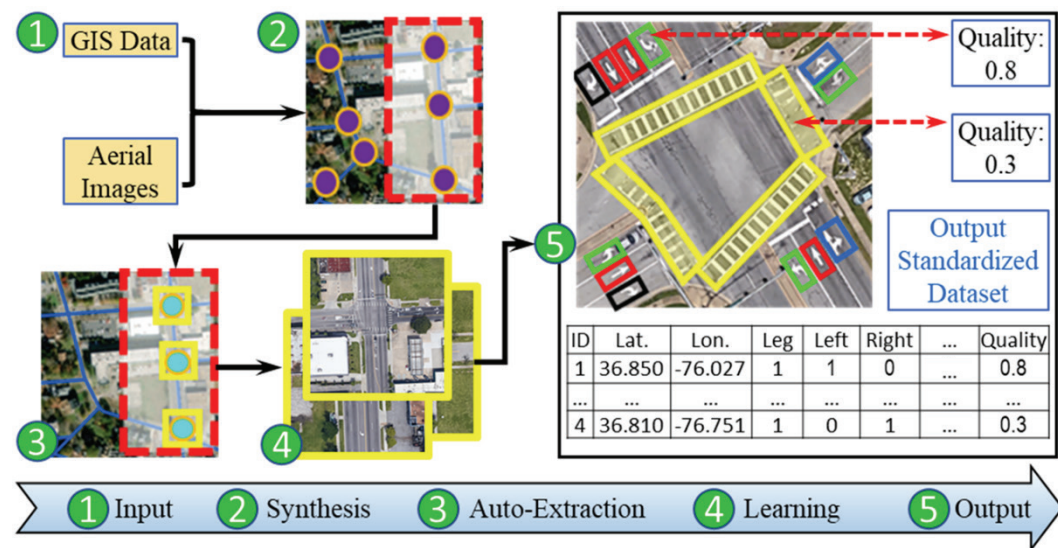

Figure 1

Conceptual illustration of the proposed automated data collection system. Ellipses represent omitted headers and data.

Project Results

Work in the current stage focuses on collecting training data and developing core modules for data acquisition and computer vision. A data acquisition module has been developed to automatically retrieve intersection locations from roadway GIS data in Virginia and capture corresponding aerial images from Google Maps and Mapbox. Over 1,000 intersection images have been captured and manually labeled. Marking images were synthesized from different environment settings, and the synthesized data were used in a transfer-learning process to pre-train computer-vision models for marking detection and characterization (as illustrated in Figure 2). Computer-vision models have been fine-tuned on the real data set, and an average precision (89%) for classifying lane-use arrows has been achieved. A multi-task deep learning model is being built that would embed conventional neural network for marking detection, characterization, and assessment of marking degradation. Work in the next stage will involve prototype development and testing and demonstration. The prototype will be built by integrating the modules developed, and a web-based graphical user interface (GUI) will be developed for the system.

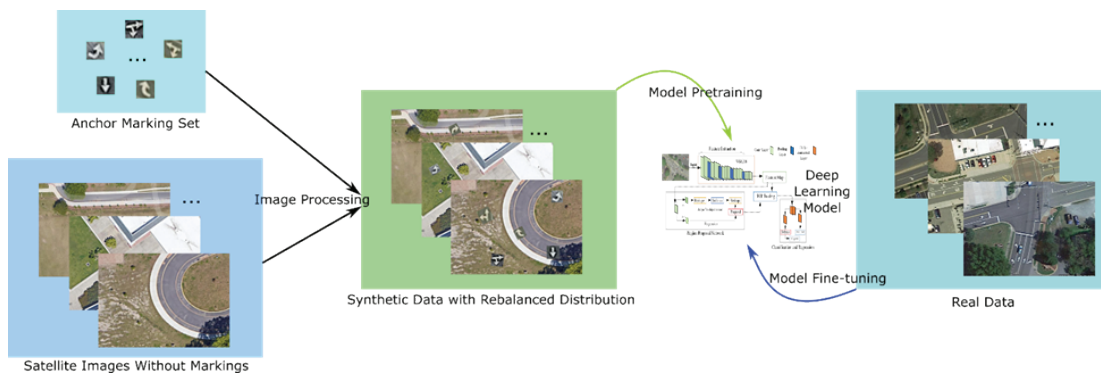

Figure 2

Illustration of transfer learning framework.

Product Pay-Off Potential

The proposed system can fully automate the processes of marking data collection and condition assessment on a large scale with almost zero cost and short processing time (e.g., in a preliminary test, the processing time per intersection is less than 0.5 seconds). Compared with current practices, for every 100,000 intersections, the proposed system can save approximately \$2,000,000 and 16,000 person-hours. The numbers of intersections on statewide road networks are very large. For example, Virginia has more than 400,000 intersections in its roadway inventory, and the expected cost savings will be magnificent. The system can help states improve their inventory databases to accommodate Fundamental Data Element requirements legislated in the MAP-21 and the FAST Acts.

Product Transfer

The proposed system will be deployed as a web-based application. After the successful development of the prototype, the research team will collaborate with the Virginia Department of Transportation (VDOT) to conduct a pilot test on its public roadway network. VDOT will provide statewide intersection GIS data and other relevant data for large-scale implementation and performance evaluation of the developed system. VDOT will also assist in incorporating collected data products into its existing roadway inventory database. With the feedback and experience learned from the pilot test, the research team will consistently improve the system to meet the needs of transportation agencies.

A SMART INTERNET OF THINGS (IoT) PROXIMITY ALERT SYSTEM FOR HIGHWAY WORK ZONE SAFETY

NCHRP-IDEA Project 226

Yong Kwon Cho [Tel.: (404) 385-2038; Email: yong.cho@ce.gatech.edu]
Georgia Institute of Technology, Atlanta, Georgia

IDEA Concept and Product

The primary objective of this research is to develop a practical alert system for alerting workers and equipment operators in proximity hazard situations in highway work zones. As shown in Figure 1, the system utilizes portable devices carried by pedestrian workers as Personal Protection Units (PPUs), directional light-enabled devices mounted on equipment as Equipment Protection Units (EPUs), and Bluetooth Low Energy (BLE) beacons for proximity detection and alert with audible sound and vibration through the devices. From the previous extensive field test experiences, the research team found a few challenges for the future commercialization and industrial acceptance of the developed system. The challenges include that the alert was not clearly perceptible in a large and noisy highway construction site, the power consumption was too high since the app program needs to be continuously running to detect proximity and send alerts, and there were too many nuisance alerts for the workers who need to work close to the equipment. To innovatively solve the problems, this research will design advanced hardware units (PPU and EPU) to improve the alert perceptiveness and usability, with the capability of lower-power mesh network communication, and develop a web-based IoT user interface for remote monitoring, nuisance alert control, PPU and EPU software and data management, and worker and equipment safety performance analyses.

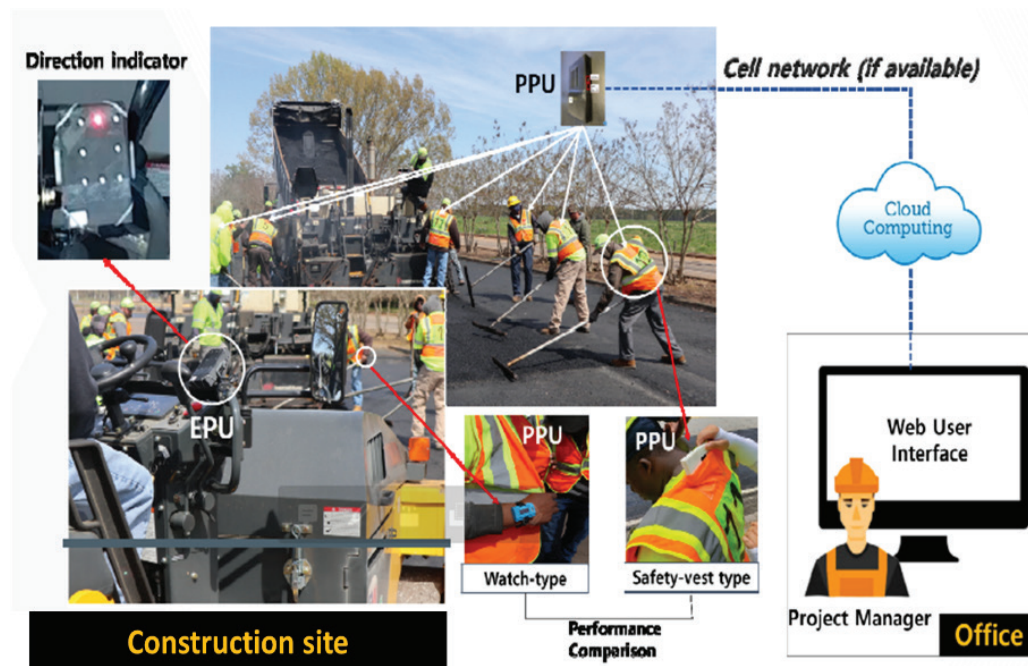

Figure 1

Concept of a smart Internet of Things (IoT) proximity alert system.

Project Results/Planned Investigation

Work in Stage 1 focuses on developing and prototyping the proposed system. A project kick-off meeting was held with the expert advisory panel. New designs of PPU and EPU have been investigated. An embedded system with a printed circuit board (PCB) for PPU and EPU in a small form has been designed and is being tested in terms of its hardware and firmware. Fundamental functionalities of a mesh network were examined, and the team is continually developing the mesh network that works for multiple PPU and EPUs. Through the hardware and firmware tests, the sensor data have been collected properly, which means the micro-processing unit in the PPU collects the sensor data from the sensor modules as desired. In Stage 2, the prototype system will be tested under various real-world field conditions to validate its effectiveness. These tests will be conducted in collaboration with Georgia DOT's construction and maintenance groups, equipment manufacturers, and general contractors.

Product Pay-Off Potential

The preliminary test results of the study at the first stage show that the previous prototype version of PPU can be resized into a smaller device without compromising the functionalities. This indicates that an IoT-based, real-time, and proactive proximity alert system can be deployed in a compact and effective way to promote safety in roadway construction work zones. In addition, the mesh network utilized in this research will allow the system to be flexibly implemented from small-scale work zones to large-scale work zones because it does not require a heavy infrastructure for wireless communication. Furthermore, there is a clear benefit with regard to the simplicity of hardware configuration. The essential required components are PPU, EPU, and BLE beacons that can be attached to any solid surface of the equipment body. In addition to the scalability, the portability and simplicity of the proposed system will allow broader onsite adoption of the proposed technology and proactive safety practices between the equipment and pedestrian workers at roadway construction work zones.

If successful, this research will provide highway construction safety and project managers with a comprehensive understanding of the job site hazard in dynamic construction work zones. Furthermore, with the aid of the proposed system, state transportation agencies can formulate a more efficient way of regulating work zone safety guidelines; therefore, a lower rate of accidents and near-misses will yield not only an improvement of workers' safety but also a decrease in project delays resulting from safety-related accidents.

Product Transfer

The research team has been continually working with state DOTs for construction and maintenance technology applications. The team is planning to test and demonstrate the proposed proximity alert system to state DOTs, construction contractors, and an equipment manufacturer. Their support will allow the utilization of a large assortment of testbeds at their working sites to analyze the effectiveness of the design and potential prototype. Also, the research team and Georgia Tech Technology License office have been working with a well-established patent law firm for examination reports and filing a patent to U.S. Patent and Trademark Office. The progress and outcomes of the proposed system will be posted on the team's Robotics and Intelligent Construction Automation Lab (RICAL) webpage (rical.ce.gatech.edu) and available in journal articles for public dissemination.

ADJUSTABLE CROSS-FRAMES FOR THE ERECTION OF STEEL GIRDER BRIDGES

NCHRP-IDEA Project 227

Ashley P. Thrall [Tel.: (574) 631-2553; Email: athrall@nd.edu]
University of Notre Dame, Notre Dame, Indiana

David D. Byers [Tel.: (816) 994-2902; Email: dbyers@genesisstructures.com]
Genesis Structures, Inc. Kansas City, Missouri

IDEA Concept and Product

The innovation is an adjustable cross-frame for curved and highly skewed steel girder bridges that will provide the necessary geometry adjustments in the adjacent girders for fit-up, while also providing a single, permanent cross-frame. This innovation addresses a major challenge in the design, fabrication, and erection of curved and highly skewed steel girder bridges: that girders twist and deflect, such that there is only one fit condition for which the girder is plumb. As a result, the installation of cross-frames in the field can be an incredibly difficult task and may require unplanned force-fitting and hole-reaming. As opposed to conventional rigid cross-frames (Figure 1), the adjustable cross-frame is idealized to be fabricated with one set of fit assumptions and field adjusted to accommodate another set of assumptions, whether that be from different erection sequencing, fabrication tolerances, camber variations, or other unanticipated geometry variations. This will maximize flexibility in fabrication and erection, while minimizing the potential for overstress in the system. The adjustable cross-frame comprises two z-frames that are prefabricated and connected to each girder prior to erection (Figure 2a). The z-frames can be attached to one another during bolt-up via bolted splice connections, forming eccentrically braced frames (Figure 2b). Minor adjustments to misalignment can be achieved through field bending splice plates via bolt tightening. Major adjustments can be made by temporarily installing pin-connected push/pull jacks in pre-determined locations (Figure 2c). This provides the necessary flexibility in geometry to ease the erection of curved and highly skewed steel girder bridges while also simplifying fabrication.



Figure 1

Steel girder bridge erection with conventional rigid cross-frames.

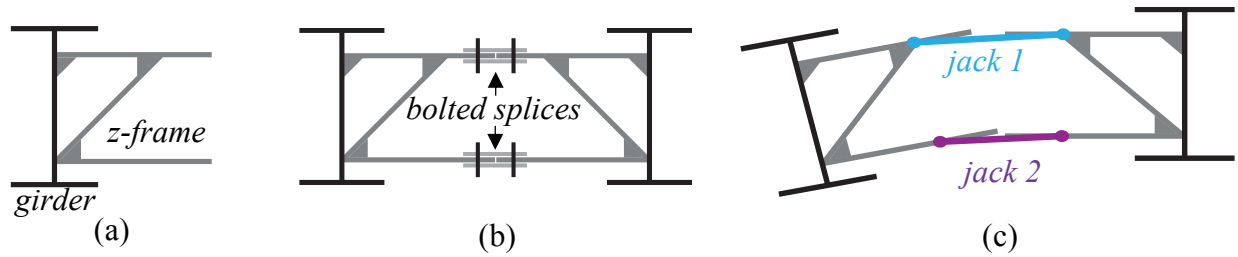

Figure 2

Proposed adjustable cross-frames: (a) Girder prefabricated with z-frame; (b) bolt-up, forming an eccentrically braced frame; and (c) adjustability for misalignment through jacks 1 and 2.

Planned Investigation

The research objectives of this project are to (1) develop novel adjustable cross-frames, (2) evaluate and numerically demonstrate feasibility, and (3) develop practical recommendations and bounds on applicability. Research tasks are divided into two, 12-month stages. Stage 1 will focus on the conceptual design of the novel adjustable cross-frames, including understanding bounds on desired adjustability and developing detailed control sequences. Stage 2 will focus on detailed numerical evaluation of the developed conceptual designs, including comparisons to conventional rigid cross-frames. A scaled prototype will also be built, demonstrated, and evaluated.

Product Pay-Off Potential

This research will approach the cross-frame fit problem comprehensively, considering the designer, fabricator, and erector's viewpoints. Erectors are forced to use multiple means to bring adjacent girders into a position to install conventional rigid cross-frames. This work is often done by using a combination of cranes, chain hoists, clamps, shoring, and so forth, which are time-consuming, complicated, and labor-intensive, often putting field labor in harm's way. Cross-frame installation problems on curved and skewed bridges often pit the designer, fabricator, and erector against each other. An adjustable cross-frame offers the possibility to significantly reduce these inherent difficulties in the design, fabrication, and erection of curved and skewed bridges.

Product Transfer

One of the primary benefactors will be the steel industry, given that curved and highly skewed bridges are often designed and fabricated in steel. An adjustable cross-frame system will provide contractors and erection engineers a tool that will assist in the field assembly of girders that is fully understood, prior to erection. This will increase speed and safety during erection.

A RETROREFLECTIVE ROAD LANE MARKING TAPE 1,000X BRIGHTER THAN EXISTING TECHNOLOGY

NCHRP-IDEA Project 228

Mark O'Neill [Tel.: (817) 380-5930, Email: markoneill@markoneill.com]

Mark O'Neill, LLC, Fort Worth, Texas

IDEA Concept and Product

The concept of this study is to use a novel optical design to dramatically improve the retro-reflectivity of traffic stripes and other road markings. Many studies have shown that brighter traffic stripes reduce the number of crashes, injuries, and deaths. Brighter traffic stripes are important not only for vehicles driven by people but also for connected and automated vehicles. As shown in Figure 1, the top surface of the new traffic stripe uses a repeating pattern of widely spaced light-turning prisms to capture and redirect light from distant vehicle headlights downward onto a bottom surface. The bottom surface comprises an array of microscopic cube corner retroreflective prisms that return the incident light rays in the opposite direction until they encounter the vehicle driver's eyes. The product is a thin transparent polymer [aliphatic thermoplastic polyurethane (TPU) is the leading candidate], with the two sets of prismatic patterns embossed into the top and bottom surfaces. This embossed polymer is installed in pavement grooves to mitigate damage from traffic and snowplows. The product can also be used on guard rails and concrete barriers to greatly enhance their visibility at night.

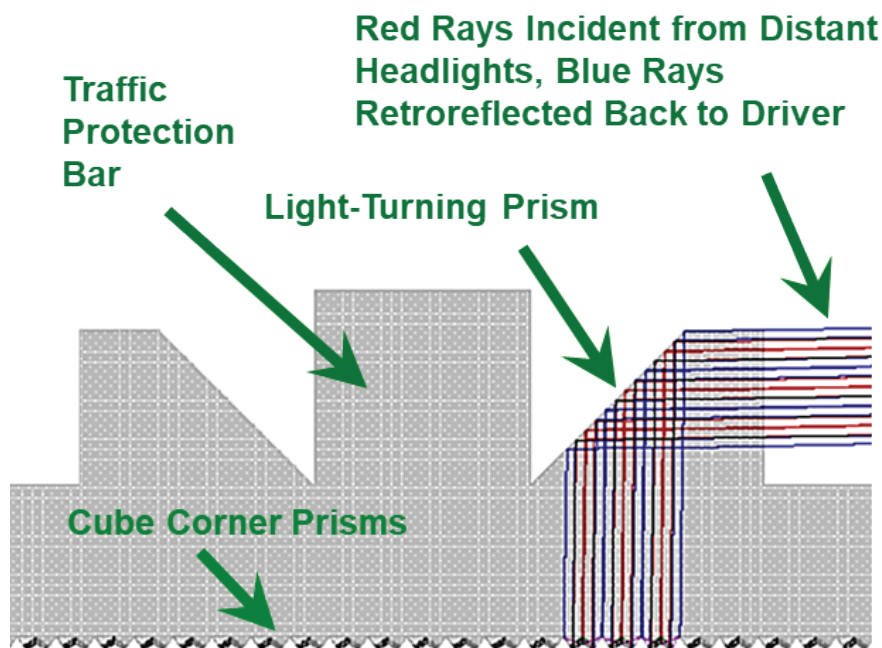

Figure 1

New ultra-bright traffic stripe.

Project Results

During the first 9 months of the program, the design of the light-turning prismatic pattern was finalized, diamond-turned tooling was created, and prototype parts were made. These prototype light-turning prismatic parts were bonded to commercially available retroreflective cube corner road sign sheeting to form the first prototypes. Four different prototypes were tested by a certified laboratory to measure the traffic stripe retroreflectivity according to ASTM standards. The values measured for the prototypes are summarized in Figure 2, with other benchmarks included for comparison. These benchmarks include the proposed U.S. minimum standard, the proposed European Union (EU) minimum standard, and the highest previous measurement for a traffic stripe of any kind. Note that the best prototype achieved about 400 times the proposed U.S. standard and about 20 times the previous highest measured value. Later production versions of the new traffic stripe are expected to reach higher performance levels than the relatively crude prototypes.

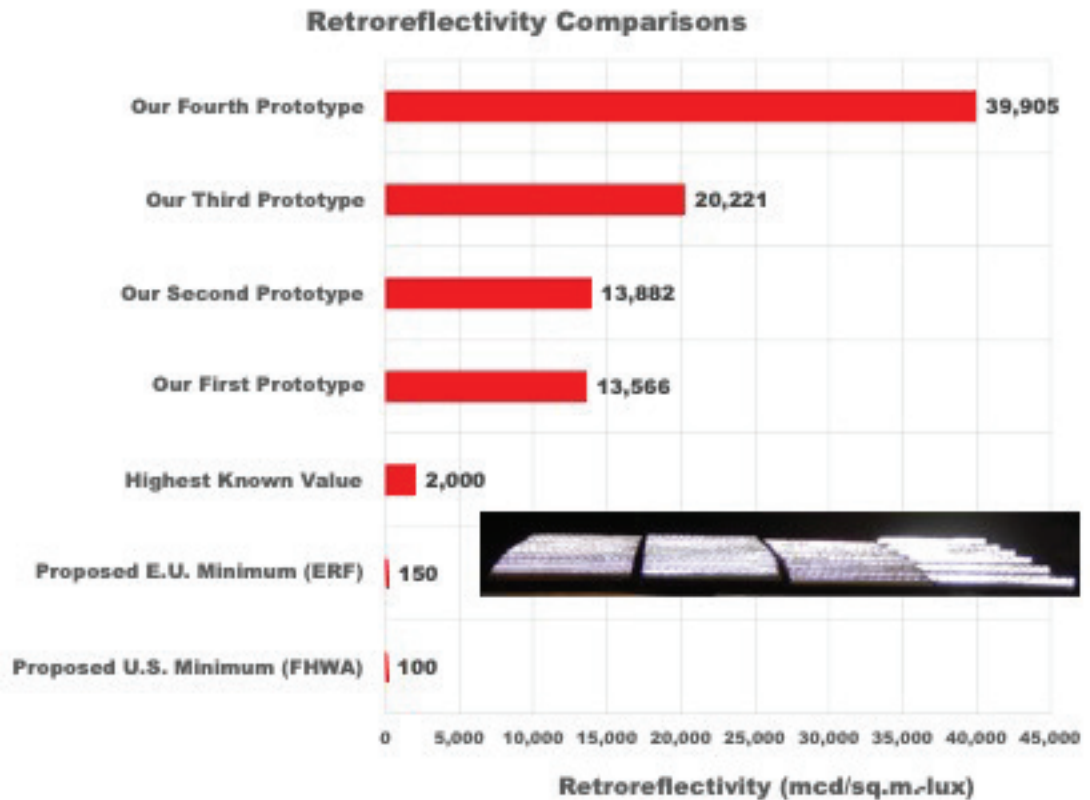

Figure 2

Certified test results compared with benchmarks (four prototypes shown in order in inset photo).

Product Pay-Off Potential

A conservative benefit-cost analysis of the new product was performed for American interstate highways by using published crash reduction factors associated with brighter edge stripes. The results showed that the new traffic stripe could pay for itself in less than 2 months by the reduction in comprehensive costs of American lives lost. More importantly, the new traffic stripe could save thousands of American lives each year on U.S. highways of all types. The new traffic stripe is also timely, with the renewed interest in modernizing American infrastructure, including the approximately 3 million miles of paved roads.

The new traffic stripe uses non-toxic American-made materials that will eventually be amenable to plant-based renewable-sourced raw materials. The new traffic stripe will replace painted traffic stripes with embedded glass or ceramic beads, which sometimes contain small amounts of toxic materials such as arsenic and lead. Since 500,000,000 pounds of these glass and ceramic beads are deposited on road markings in the United States each year, the new traffic stripe will offer significant environmental, health, and safety benefits to many people, including manufacturing workers, supply chain workers, highway workers who install and remove traffic stripes, and families living near American highways.

Product Transfer

In the final months of this project, the project team will produce and install two small prototypes on highways in two parts of the country, one prototype in the Snowbelt and one prototype in the Sunbelt. The team will also finish a roadmap for completing the development and commercialization of this exciting new traffic stripe technology. The team is confident of successfully commercializing the new technology to save lives on American highways.

LABORATORY DIELECTRIC MEASUREMENT SYSTEM (LDMS) FOR ASPHALT MIXTURE BULK SPECIFIC GRAVITY DETERMINATION

NCHRP-IDEA Project 229

Jo E. Sias [Tel.: (603) 862-3277, Email: jo.sias@unh.edu]

Eshan V. Dave [Tel.: (603) 862-5268, Email: eshan.dave@unh.edu]

Anh Tran [Tel.: (763) 339-9374, Email: adt1022@wildcats.unh.edu]
University of New Hampshire, Durham, New Hampshire

IDEA Concept and Product

Bulk specific gravity (G_{mb}) is routinely measured during mixture design and quality assurance processes to ensure adequate and uniform density in asphalt pavements. The traditional procedures, AASHTO T 166 and AASHTO T 331, used to measure G_{mb} require multiple pieces of laboratory equipment and can have substantial measurement error with some types of asphalt mixtures. This project is exploring a laboratory dielectric measurement system (LDMS) for determining the G_{mb} of compacted asphalt specimens as an alternative and more efficient approach to the traditional test procedures. The setup for the LDMS is a miniaturized ground-penetrating radar source and receiver (Figure 1). Dielectric constant measurements are collected using the LDMS for asphalt concrete specimens of geometry similar to that typically used in mixture design and production quality assurance processes. The project is expected to establish the relationship between dielectric constant and G_{mb} and the factors (specimen geometry, surface characteristics, and asphalt mixture types) that influence it. The project is also expected to develop a test specification that captures the testing procedure, specimen needs, and equipment needs and that discusses analysis procedures that need to be developed for adoption by agencies and contractors.



Figure 1

Photo of the LDMS setup showing a gyratory compacted asphalt specimen.

Project Results

The project consists of two stages. Work in Stage 1 focuses on establishing the reliability and standardizing the procedure for the LDMS. This includes an evaluation of the impact of specimen geometry, surface condition, and mix design variables on dielectric measurements and drafting a test specification. In Stage 2, a relationship between dielectric value and G_{mb} will be established, with the goal of replacing asphalt mixture laboratory G_{mb} measurements with laboratory dielectric measurements.

The project is mid-way through Stage 1. A sampling plan was developed based on information obtained through a survey of state DOTs (through AASHTO COMP members) to gather information on planned asphalt mixture production for the 2021 construction year. Various state DOTs participating in the TPF-5(443) pooled fund study (Continuous Asphalt Mixture Compaction Assessment using Density Profiling System) were also contacted to maximize overlap between materials that will be tested in the field using DPS and materials evaluated in this IDEA project using LDMS. Through these efforts, mixtures that cover a range of aggregate types (specifically in terms of dielectric values) and nominal maximum aggregate sizes were identified and sampled. The first set of specimens was fabricated with varying densities and tested with LDMS using different orientations, as seen in Figure 2a. From the dielectric test result (Figure 2b), it is shown that as G_{mb} decreases (i.e., air void increases), laboratory measured dielectric values increase. Multiple measurements were collected at each orientation to study repeatability. Various groupings of measurements are being statistically analyzed to determine the appropriate number of measurements needed to determine the average dielectric constant of the specimen. An experimental plan for the specimen fabrication and LDMS testing of the remaining sampled materials is under development.

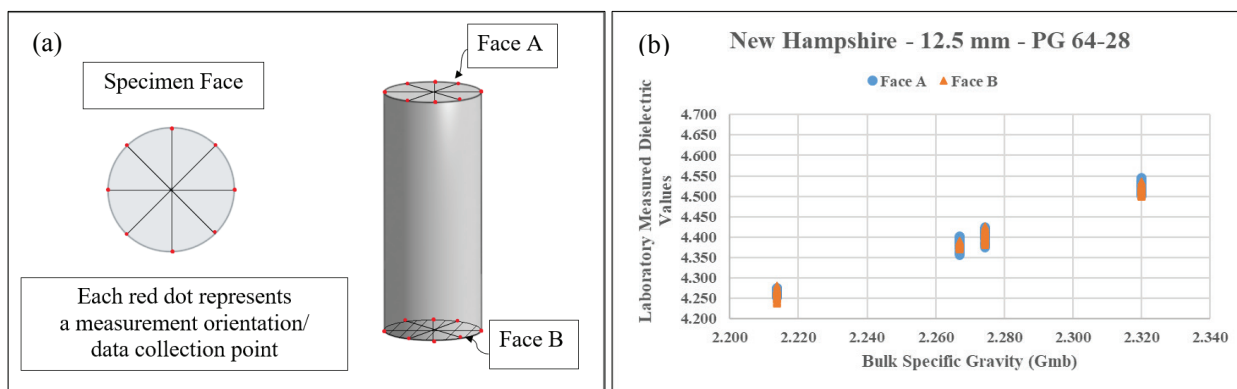

Figure 2

(a) Schematics of LDMS testing and (b) test results of the first set of specimens from New Hampshire.

Product Pay-Off Potential

Implementation of the LDMS has the potential to provide significant advantages in terms of efficiency and accuracy in measuring G_{mb} of asphalt mixtures in the laboratory as compared with the traditional procedures that require multiple pieces of laboratory equipment and significant operator time for G_{mb} measurement than the dielectric measurement approach. The use of LDMS also has the potential to alleviate the challenges in terms of variability in G_{mb} measurements and variation in the resulting calculated air voids and will result in more efficient laboratory operations, as well as more economical operation since only one piece of equipment would be needed. Lastly, portability of LDMS makes it better suited for field laboratories, where traditional G_{mb} measurement requires use of a temperature-controlled water bath.

Product Transfer

Successful transfer of the LDMS to practice will require effective communication and training on the new test and analysis procedure. One product of the research will be a draft AASHTO specification and procedure based on the results from this project. Web-based video materials targeted for agency and contractor engineers and technicians will be developed to explain the LDMS approach as well as to provide detailed testing and measurement procedures. These training materials will alleviate potential impediments to implementation due to lack of familiarity and experience with the LDMS. A simplified tool to calculate G_{mb} of asphalt mixtures using measurements from LDMS (such as an Excel spreadsheet) will be developed and made publicly available as a project outcome.

AUTOMATED DATA AND FEATURE EXTRACTION FROM BRIDGE PLANS

NCHRP-IDEA Project 230

Behrouz Shafei [Tel.: (515) 294-4058; Email: shafei@iastate.edu]
Iowa State University, Ames, Iowa

IDEA Concept and Product

With a focus on both engineering and economic analyses, bridge asset management programs are intended to identify an appropriate sequence of maintenance, preservation, repair, rehabilitation, and replacement actions to achieve and sustain a desired condition state for bridges (with a minimum practicable cost over their expected life cycle). As reflected in both the MAP-21 and FAST Acts, quality information plays a central role in this process, ensuring that the predictive models and planning activities receive accurate and reliable input (in a timely manner). This motivated the current project researcher to develop a computational platform to automate the process of data and feature extraction from available bridge plans, with the ultimate goal of quick delivery of high-quality information about the engineering details of interest.

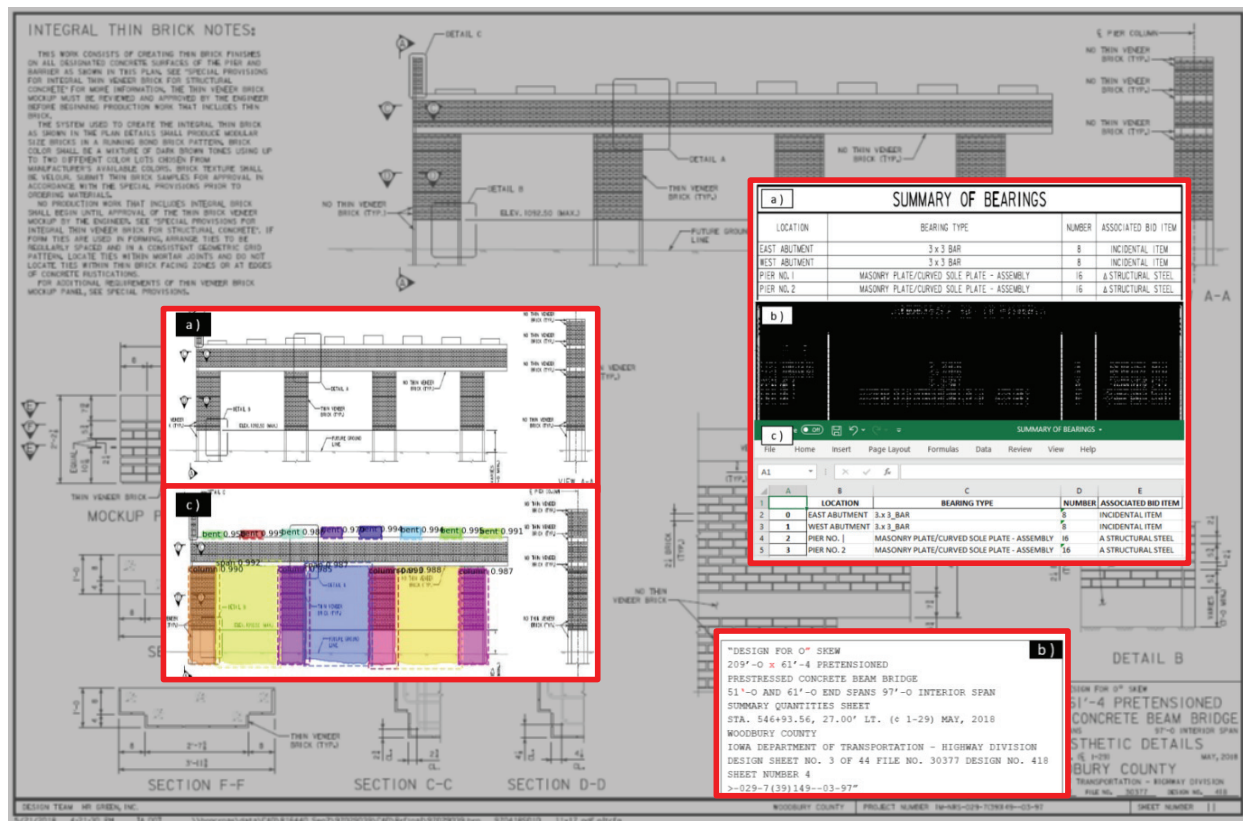

Figure 1

An end-to-end process that will deliver the bridge-related information to state highway agencies with a high accuracy and in a timely manner. This process will cover the variety of information provided in typical bridge plans in the form of drawings, tables, and text blocks.

Planned Investigation

Capitalizing on the state-of-the-art machine learning and artificial intelligence algorithms, this research project aims to transform the current practice of manual data and feature extraction from bridge plans by introducing a computational platform that will automate the entire process of reviewing, finding, extracting, and reporting engineering details from them. For this purpose, a holistic review of a variety of bridge plans will be performed to identify and categorize the engineering details that are expected to be extracted from them. Upon developing the necessary algorithms, their accuracy and speed will be systematically assessed. This will begin from the verification stage to ensure that the automated platform returns correct outputs for the bridge plans used during the training of the algorithms. The quality control effort will then be extended to the validation stage, in which the developed platform will be tested on several bridge plans not used for training purposes. The generated outputs will be compared to those obtained from manual extraction, ensuring that possible deviations are properly identified and addressed.

Product Pay-Off Potential

The immediate pay off of the computational platform that will be developed in this research project is a drastic reduction in the time and effort required for reviewing, finding, extracting, and reporting the bridge details of interest. Thus, the outcome of this project is expected to be implemented by state highway agencies as a new tool that will be used by a diverse group of engineers and staff members. In particular, those involved in the inspection, maintenance, and management of bridges will be primary users. In addition, the personnel working on the transportation infrastructure safety, planning, operation, and research will be able to benefit from this platform in their daily tasks and activities.

Product Transfer

Through direct interactions with the state highway agencies, the capabilities of the developed computational platform will be introduced, outlining how the platform contributes to significantly reducing the time and labor required for data and feature extraction from bridge plans. In addition, the outcome of this project will be disseminated through presentations at the Transportation Research Board Annual Meetings and the AASHTO Committee on Bridges and Structures Annual Meetings. Each of these annual meetings regularly attracts several representatives from departments of transportation and the bridge industry. This will help make a wide spectrum of engineers aware of the developed computational platform and encourage them to consider implementation.

AI ANALYZER FOR REVEALING INSIGHTS OF TRAFFIC CRASHES

NCHRP-IDEA Project 231

JeeWoong Park [Tel.: (702) 895-1568; Email: jee.park@unlv.edu]

Cristian Arteaga [Tel.: (702) 427-4847; Email: arteagas@unlv.nevada.edu]
University of Nevada at Las Vegas, Las Vegas, Nevada

Alexander Paz [Tel.: 61 (731) 381-157; Email: alexander.paz@qut.edu.au]
Queensland University of Technology, Brisbane, Queensland, Australia

IDEA Concept and Product

The project will develop a software solution that uses artificial intelligence (AI) to analyze traffic crash narratives and support traffic safety engineers to better understand the factors associated with traffic crash severity. These factors will be extracted from the rich information contained in crash narratives, which detail the contexts and characteristics of crashes; they will then be interpreted to obtain insights for deep crash understanding and support data-driven decision making. To date, crash narratives have not been fully leveraged, due to limitations in technical text analysis methods and difficulty associated with manually reading thousands of narratives. In view of these limiting factors, this study proposes a tool (Figure 1) that implements the analysis of a massive number of crash narratives, requiring minimal analyst intervention, and helps leverage this important information source. Analysts only need to load crash data into the system, select execution parameters, and click a button to run the analysis. The software processes the narratives using a developed AI approach and returns a set of potential severity contributors in the form of words (unigrams) or groups of words (e.g., bigrams and trigrams).

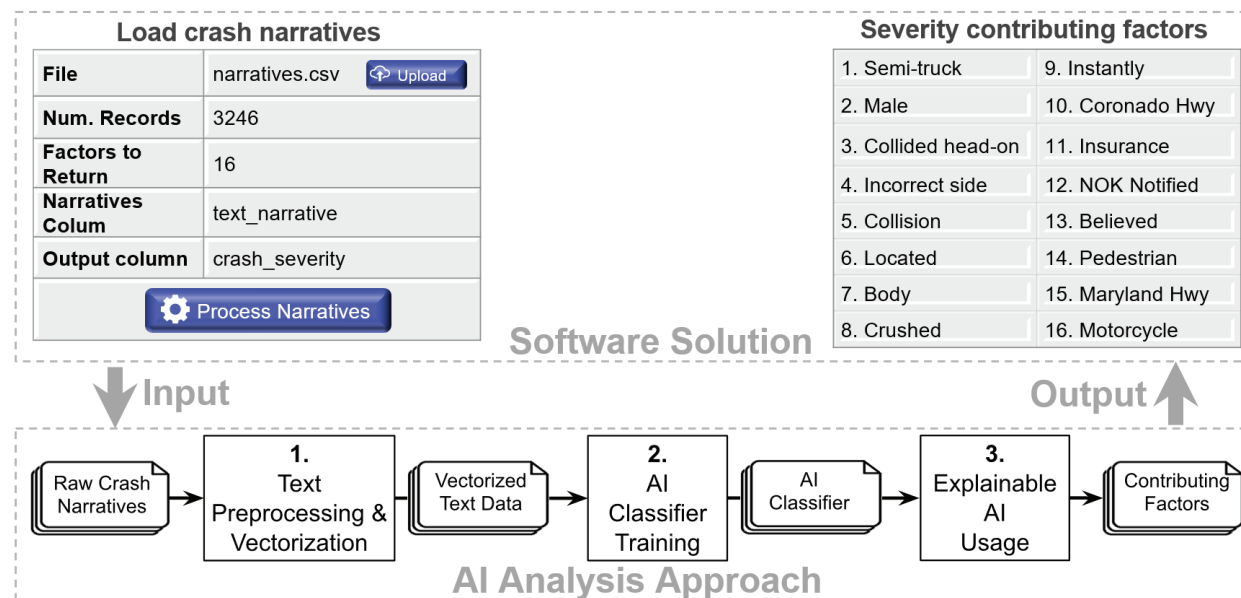

Figure 1

Illustration of proposed software solution and AI analysis approach.

Planned Investigation

This research will investigate and adapt recent technical advancements in Natural Language Processing (NLP) (an AI subfield) to identify the parts of the narratives correlated with severe crashes. The investigation will be divided into two stages. Stage 1 will focus on developing the AI methodology, along with the associated software solution. A literature review will be conducted to identify NLP text classification techniques that offer an equilibrium between predictive performance, interpretability, and computational complexity, and thereby meet the requirement for practical application. In addition, this stage will include the evaluation and fine-tuning of multiple NLP approaches for the text classification task, and their integration into the software tool. Stage 2 will focus on validating the developed software and refining it for practical application. First, results obtained with the system will be compared with results from classical analysis of quantitative data by using statistical techniques, such as discrete outcome models, to validate the consistency of the results. Second, the results obtained during project development will be discussed with safety analysts from our partner agencies to corroborate their validity.

Product Pay-Off Potential

The proposed solution offers significant value to the current practice in traffic safety analysis data by allowing analysts to exploit crash narratives as an additional data source with rich information on crash context and characteristics. The most noteworthy contribution is a novel data-processing tool using state-of-the-art AI techniques that facilitate the identification of potential severity contributing factors. This is expected to help researchers and policy-makers design and prioritize better-targeted countermeasures to reduce future crash severity. For instance, the proposed solution can support the “diagnosis” step of Part B: Roadway Safety Management Process suggested by the *2010 AASHTO Highway Safety Manual* to expand the understanding of factors that worsen crash severity to further select and perform an economic appraisal of potential countermeasures. By overcoming the existing limitations, the proposed system aims to reinforce crash analysis with an application of AI on crash narratives, and thus take advantage of all information available in crash reports. Rather than substituting existing analysis techniques, the proposed system intends to expand and corroborate insights obtained through classical analysis approaches to increase confidence in the relevance of the severity contributing factors identified across different techniques.

Product Transfer

Several strategies have been planned to transfer to practice the outcomes of this project. First, the developed software will be released under an open-source license for distribution to a broader audience. This will enable agencies across the United States to download it and analyze their own crash narratives, as well as freely explore and revise the algorithms to integrate further evolving techniques, if needed. Second, a webinar directed at transportation agencies will be conducted in order to showcase the tool and provide guidance for usage. Third, training resources will be provided by including standard documentation, training videos, and guides on the website where information about the system is shared. Finally, the research findings will be disseminated in journal and conference articles and at the annual meetings of the Transportation Research Board and the Institute of Transportation Engineers.

MEASURING CONCRETE PERMEABILITY WITH THE CHIP

NCHRP-IDEA Project 232

Tyler Ley [Tel.: (405) 744-5257; Email: tyler.ley@okstate.edu]

Qinang Hu [Email: qinang@ostatemail.okstate.edu]

Dan Cook [Email: marllon.cook@okstate.edu]
Oklahoma State University, Stillwater, Oklahoma

IDEA Concept and Product

Developed in a previous NCHRP-IDEA project (NCHRP-IDEA Project 199), the CHIP (checking ion penetration) device was designed as a non-destructive, practical, fast, safe, and inexpensive approach to measuring the rate of fluid penetration into paste, mortar, or concrete using X-rays. The current version of this direct permeability measurement takes 7 days and has been completed by taking a 1-inch core and capturing an X-ray image or radiograph of the concrete before and after a tracer or electron-dense liquid penetrates through the sample.

Project Results and Planned Investigation

Most life-cycle analysis models for concrete use the diffusion coefficient to predict the service life. The CHIP can determine the diffusion coefficient by using X-rays to image the sample before and after being pounded with a tracer for 7 days. By subtracting these two images, the penetration of the tracer can be seen. An example of the results is shown in Figure 1(a). Quantitative measurements of the tracer can be found by using the intensity values from the images and using standards to change this information into concentration. These standards are for concrete with known amounts of tracer added. These standards do not need to be used again as they indicate the amount of signal in the machine to the amount of tracer present in the sample. The final results are shown in Figure 1(b). These concentrations quantify the amount of the tracer that has penetrated into the concrete. From this graph, a diffusion coefficient can be found.

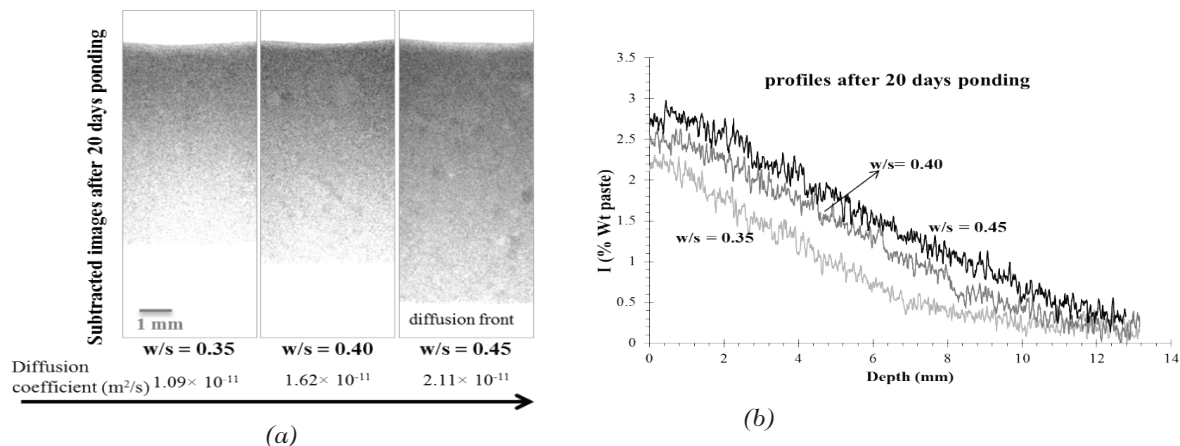

Figure 1

(a) Ion penetration and (b) ion concentration profile of three mixtures.

Although a functioning prototype was created in the previous NCHRP-IDEA project, improvements in the functionality of the software and equipment, reduction in the length of the test, and development of new case studies to show the usefulness of the device are needed to gain the confidence of state highway administrations (SHAs), the FHWA, and AASHTO.

Product Pay-Off Potential

This research is the first step in establishing a product to give SHAs an inexpensive and powerful tool that could be used in the laboratory and in the field to directly determine the permeability of their concrete infrastructure. This device could be used to evaluate concrete mixture designs and compare construction practices such as finishing, consolidation, and curing. This means that the measurements would be from the in-place properties of the concrete. This could warn the owner if a problem was occurring during the construction process. In addition, this method could be used to compare the effectiveness of different repair materials or the use of surface sealers to prolong the service life of the concrete. This would allow SHAs greater insight into the performance of their existing and new concrete structures.

Product Transfer

While the CHIP shows promise to be an extremely powerful tool to evaluate the quality of concrete permeability, the instrument must be made more practical and user-friendly and more case studies are needed. The case studies proposed in this work to investigate concrete permeability at the mixture design, after placement, and after curing as well as the investigation of surface treatments and repair materials will provide convincing results. This will give direct evidence to Illinois, Minnesota, and Oklahoma of the value of the CHIP over current test methods. Furthermore, the FHWA mobile concrete laboratory has agreed to add the improved CHIP to their mobile concrete trailer. This is a mobile laboratory that is taken to different states to showcase new technologies and to use these technologies in ongoing projects to show the value to the SHAs. This exposure from the FHWA mobile laboratory will help others learn about the CHIP; the exposure will also gather data from a number of different projects. These results will then be shared with other SHAs, the FHWA, and AASHTO through personal contacts, the sharing of results at conferences, and via YouTube videos. After obtaining the interest of owners, efforts will be made to contact testing companies and show them the usefulness of the CHIP.

The researchers plan to partner with Gilson, which is the largest construction testing equipment manufacturer in North America. The research team already has a relationship with Gilson and a signed non-disclosure agreement to collaborate on developing concrete testing equipment. Another partner may be a dental X-ray equipment company such as Gendex to help obtain the X-ray equipment at wholesale prices and to ensure the long-term safety of the equipment. These partnerships will be investigated in more detail as the time gets closer to commercialize the CHIP.

DEVELOPMENT OF AN INNOVATIVE BIO-MEDIATED SELF-HEALING CONCRETE TECHNOLOGY

NCHRP-IDEA Project 233

Xiong (Bill) Yu [Tel.: (216) 368-6247; Email: xxy21@case.edu]
Case Western Reserve University, Cleveland, Ohio

IDEA Concept and Product

The proposed innovation is a fungi-mediated self-healing concrete technology. It is expected to rapidly heal concrete cracks by using fungi to rapidly cover the exposed crack surfaces and seal the cracks with bio-mineralization processes (Figure 1). In addition, the hydrophobic nature of the fungi fiber will ensure water tightness and prevent water ingress into cracks. Overall, the technology will recover the mechanical properties and water tightness of cracked concrete autogenously and rapidly. This will lead to major savings in cost and labor compared with conventional crack treatment procedures. This innovative autogenously self-healing concrete technology will significantly improve the longevity and performance of bridge decks and other concrete structures.

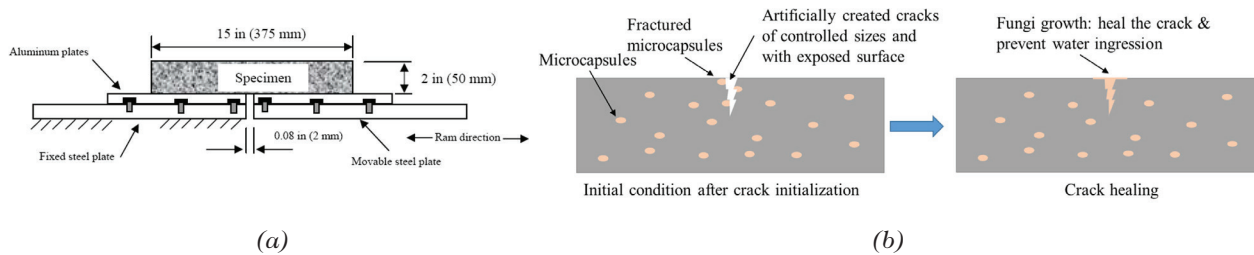

Figure 1

(a) Schematic set up to induce non-structural cracks in curing concrete with restraint and (b) illustration of evaluation of self-healing concrete.

Project Results and Planned Investigation

The research activities will be divided into two stages. Stage 1 will focus on developing a fungi-based self-healing agent for concrete mixture. The project will begin with a meeting with an expert advisory panel consisting of experts with experience in pedestrian facility data analysis, traffic inventory data collection, and database management. Subsequently, the team will determine fungi strain to achieve maximum survival, growth, and performance for concrete crack healing. With the fungi strain, it will develop protection strategies such as encapsulation to protect the spore to endure the mechanical loads during concrete mixing process and help them to survive the possible long dormancy period inside the concrete matrix. It will develop proper encapsulation procedures to produce fungi-based self-healing admixture. The microcapsules will be designed to ensure fungi spore survival and therefore to achieve the self-healing performance. A Stage 1 report will be prepared detailing all data, methods, and model development included in Stage 1. Work in Stage 2 will focus on evaluating the performance of fungi-based self-healing concrete under laboratory and field conditions and developing a practice-ready product based on the experimental observations as well as on feedback from stakeholders. The team will work with project partners to develop practice-ready products. The team will also work with ACI and ASTM committees to explore opportunities to develop standardized procedures. The targeted products include the patent application, a specification for a self-healing agent, and guidelines for application of the self-healing concrete.

Product Pay-Off Potential

Cracks in concrete structures significantly compromise their durability. Cracks are commonly observed in bridge decks at different stages of service, due to early age volume shrinkage, or long-term service loads, and climate conditions (i.e., dry-wet cycles, freeze-thaw cycles). Non-structural cracks generally do not pose an immediate safety concern. However, they compromise the service life of bridge decks by allowing water and salt ingress that accelerate rebar and concrete corrosion. Bridge deck rehabilitation and replacement are typically the largest share of bridge maintenance cost during the service period of a highway bridge. The large number of bridges and distributed nature of transportation infrastructure makes it difficult to timely inspect and treat concrete cracks with conventional maintenance procedures. Therefore, autogenous healing concrete cracks with no need of human intervention, that is, self-healing concrete, have unique advantages. The self-healing concrete technology to be developed in this project is conceived as microcapsules containing a fungi-based self-healing agent, which can be introduced into fresh concrete mix as a new types of admixture. From this, fast and autogenous concrete crack healing can be sustained over its service life. The healing includes recovery of the mechanical strength of concrete with a fungi-induced biomineralization process. The healing also includes improved water tightness with hydrophobic fungi fiber, which prevents water and deicing salt ingress. Implementation of this innovative technology will significantly improve the longevity of bridge decks and other concrete structures.

Product Transfer

This task will implement technology transfer activities to facilitate the implementation of this new self-healing concrete technology. A strong partnership with state DOTs and industry has been formed to explore opportunities for field demonstrations of the technology. The project partners include the Ohio DOT and BASF (a leading construction chemical supplier). The Ohio DOT unit that experienced extensive crack-induced bridge deck deterioration has committed to support the technology demonstration at its construction sites. As this technology has potential benefits for transportation infrastructure nationwide, a joint public and private implementation can potentially be launched to explore commercialization opportunities. The team will actively disseminate the research outcome at various forums, including the TRB annual conferences, the ACI Congress, and relevant AASHTO technical committee meetings.

SECTION 3

NSF/NRC-IDEA COOPERATIVE PROJECTS

The projects described in this section were funded jointly by the IDEA Program and the National Science Foundation (NSF) under a collaborative arrangement between NRC/TRB and NSF. The projects were funded in two separate yet interrelated parts. The basic science part (theoretical investigations and analytical verifications) was supported by an NSF grant, while the IDEA funds and contracts were used to develop and test the research product in a practical setting and to transfer results to highway applications. This collaborative research program has been completed.

CONTROL SYSTEM FOR HIGHWAY LOAD EFFECTS

NSF/NCHRP-IDEA Project 1

Andrzej S. Nowak [Tel.: (313) 764-8495, Fax: (313) 764-4292]

University of Michigan, Ann Arbor, Michigan

The project developed and field tested an integrated monitoring system for highway load effects control (Figure 1). The system includes a weigh-in-motion (WIM) truck weight measurement, fatigue load spectra measurement, and failure detection systems. The integrated system coupled with analytical procedures (development of load spectra, component-specific diagnostic test, prediction of remaining fatigue life) was applied for monitoring and providing bridge loading diagnostics. The system proved to be effective on truck parameters (weight, axle loads, speed, lane position, multiple presence) and load effects (girder moments and shears, component-specific strain and stress, fatigue load spectra) for estimating the health and remaining life of the bridge.

The system has the potential to serve as an efficient control measure to monitor highway loads for bridge diagnostics (evaluation of site-specific bridge condition) and management. The results of this project are on the way to implementation by the Michigan Department of Transportation (MDOT). The project team works closely with the technical staff of MDOT. The field work was carried out on bridges selected in coordination with MDOT. Some of the most efficient results that have already been implemented include WIM measurements and proof load testing. The developed procedures have been used by MDOT for evaluation of selected partially deteriorated bridges. The investigators are extending the project to focus on developing a remote-sensing device for measuring lane-specific truck parameters to arrive at practical procedures for active and passive control of truck load effects and to improve prediction of life expectancy and reliability of bridge structures based on WIM measurement.

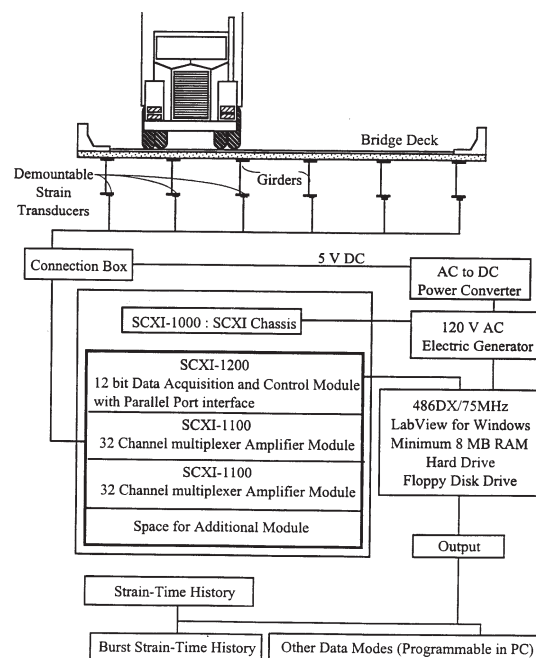

Figure 1

Data acquisition and control system.

PULSE-ECHO TOMOGRAPHIC MICROWAVE IMAGING SYSTEMS FOR QUANTITATIVE NDE OF CIVIL STRUCTURES AND MATERIALS

NSF/NCHRP-IDEA Project 2

Hua Lee [Tel.: (805) 893-4480, Fax: (805) 893-3262], University of California, Santa Barbara, California

The objective of this research is to develop pulse-echo tomographic imaging techniques for quantitative nondestructive evaluation (NDE) of civil structures and materials. Pulse-echo impulse radar provides a means of detecting voids, cracks, and the condition of concrete reinforcement bars. The ability to recognize and identify the constitution of detected objects is also useful for NDE of civil structures. Classification of the material type permits the confirmation of design specifications and a more accurate evaluation of unknown areas.

Pulse-echo radar transmits a pulse and performs time-delay estimation on the received echoes to form the time-delay profile. A Fourier transform is used to decompose the returns into their frequency components. The frequency components are individually back-propagated to create a wavefield of the area. The wavefields are then superimposed to reconstruct the image area. A singular value decomposition of the wavefield at a target is used to generate a signature vector that minimizes the sum of all distances from each wavefield to its projection onto the vector. Signatures of different materials are stored in a database for comparison to the signatures of unidentified targets. Matches are performed by computing the magnitude of the inner product with each signature in the database. Objects are identified by matching multiple signatures from the target and applying majority rule.

The investigators successfully developed and implemented the image reconstruction algorithm for the data acquisition system and operating configuration. The utilization of wavefield statistics for accurate image formation was optimized and pattern recognition techniques were evaluated. Matching and recognition experiments were performed to demonstrate the application of the technique to evaluate civil structures.

Five classes of materials were used to test the object recognition method. The five targets included an air void, air permeated concrete, a full water occlusion, the air portion of an air/water mix, and the water portion of the air/water mix. All targets were embedded in concrete. The results showed that the technique identified all targets correctly. In fact, the object recognition scheme was able to correctly identify all classes of test objects with as few as 5 test set vectors.

The technique is being used in industrial applications at the Special Technologies Laboratories of the University of California, Santa Barbara. The California Department of Transportation is planning to use the technology in conjunction with the Lawrence Livermore National Laboratory system for bridge inspection. Cooperation for implementing the technology will be available from the NSF University/Industry Research Center on High-Speed Image Processing.

The National Academies of
SCIENCES • ENGINEERING • MEDICINE

The nation turns to the National Academies of Sciences, Engineering, and Medicine for independent, objective advice on issues that affect people's lives worldwide.

www.nationalacademies.org