

**Modifications for *AASHTO LRFD Bridge Design Specifications*
to Incorporate or Update the *Guide Specifications for Design*
of *Pedestrian Bridges***

Requested by:

American Association of State Highway
and Transportation Officials (AASHTO)

Standing Committee on Highways

Prepared by:

Thomas P. Murphy, Ph.D., P.E., Associate
and
John M. Kulicki, Ph.D., P.E., Chairman/CEO
Modjeski and Masters, Inc
4909 Louise Drive, Suite 201
Mechanicsburg, PA 17055

January 2009

The information contained in this report was prepared as part of NCHRP Project 20-07, Task 244, National Cooperative Highway Research Program, Transportation Research Board.

Acknowledgements

This study was requested by the American Association of State Highway and Transportation Officials (AASHTO), and conducted as part of National Cooperative Highway Research Program (NCHRP) Project 20-70. The NCHRP is supported by annual voluntary contributions from the state Departments of Transportation. Project 20-07 is intended to fund quick response studies on behalf of AASHTO Subcommittee on Bridges and Structures. The report was prepared by Thomas P. Murphy, Modjeski and Masters, Inc. The work was guided by a task group which included Dr. Lian Duan, Susan E. Hida, Thomas P. Macioce, Jiten Soneji, Jonathan VanHook, Kevin Western, and Dr. Bojidar Yanev. The project was managed by David Beal, NCHRP Senior Program Officer.

Disclaimer

The opinions and conclusions expressed or implied are those of the research agency that performed the research and are not necessarily those of the Transportation Research Board or its sponsors. This report has not been reviewed or accepted by the Transportation Research Board's Executive Committee or the Governing Board of the National Research Council.

FINAL DRAFT

LRFD GUIDE SPECIFICATIONS FOR THE DESIGN OF PEDESTRIAN BRIDGES

TABLE OF CONTENTS

1—GENERAL.....	1
1.1—SCOPE.....	1
1.2—PROPRIETARY SYSTEMS.....	1
1.3—COLLISION MITIGATION.....	1
2—PHILOSOPHY.....	2
3—LOADS.....	2
3.1—PEDESTRIAN LOADING (PL).....	2
3.2—VEHICLE LOAD (LL).....	3
3.3—EQUESTRIAN LOAD (LL).....	4
3.4—WIND LOAD (WS).....	4
3.5—FATIGUE LOAD (LL).....	5
3.6—APPLICATION OF LOADS.....	5
3.7—COMBINATION OF LOADS.....	5
4—FATIGUE.....	5
4.1—RESISTANCE.....	5
4.2—FRACTURE.....	6
5—DEFLECTIONS.....	6
6—VIBRATIONS.....	6
7—STABILITY.....	7
7.1—HALF-THROUGH TRUSSES.....	7
7.1.1—Lateral Frame Design Force.....	7
7.1.2—Top Chord Stability.....	7
7.1.3—Alternative Analysis Procedures.....	9
7.2—STEEL TWIN I-GIRDER AND SINGLE TUB GIRDER SYSTEMS.....	10
7.2.1—General.....	10
7.2.2—Lateral Torsional Buckling Resistance - Twin I-Girder.....	10
7.2.3—Lateral-Torsional Buckling Resistance-Singly Symmetric Sections.....	11
8—TYPE SPECIFIC PROVISIONS.....	11
8.1—ARCHES.....	11
8.2—STEEL TUBULAR MEMBERS.....	11
8.2.1—General.....	11
8.2.2—Detailing.....	12
8.2.3—Tubular Fracture Critical Members.....	12
8.3—FIBER REINFORCED POLYMER (FRP) MEMBERS.....	13

1—GENERAL

1.1—SCOPE

These Guide Specifications address the design and construction of typical pedestrian bridges which are designed for, and intended to carry, primarily pedestrians, bicyclists, equestrian riders and light maintenance vehicles, but not designed and intended to carry typical highway traffic. Pedestrian bridges with cable supports or atypical structural systems are not specifically addressed.

These Guide Specifications provide additional guidance on the design and construction of pedestrian bridges in supplement to that available in the *AASHTO LRFD Bridge Design Specifications (AASHTO LRFD)*. Only those issues requiring additional or different treatment due to the nature of pedestrian bridges and their loadings are addressed. Aluminum and wood structures are adequately covered in *AASHTO LRFD*, and as such are not specifically addressed herein.

Where two letter abbreviations are used in Article 3, they relate to the loads and load combinations given in Table 3.4.1-1 of *AASHTO LRFD*.

Implementation of the wind loading and fatigue loading provisions require reference to the *AASHTO Standard Specifications for Structural Supports for Highway Signs, Luminaries and Traffic Signals (AASHTO Signs)*.

1.2—PROPRIETARY SYSTEMS

Where proprietary systems are used for a pedestrian bridge crossing, the engineer responsible for the design of the system shall submit sealed calculations prepared by a licensed Professional Engineer for that system.

1.3—COLLISION MITIGATION

AASHTO LRFD Article 2.3.3.2 specifies an increased vertical clearance for pedestrian bridges 1.0 ft. higher than for highway bridges, in order to mitigate the risk from vehicle collisions with the superstructure. Should the owner desire additional mitigation, the following steps may be taken:

- Increasing vertical clearance in addition to that contained in *AASHTO LRFD*
- Providing structural continuity of the superstructure, either between spans or with the substructures

C1.1

This edition of the Guide Specifications was developed from the previous Allowable Stress Design (ASD) and Load Factor Design (LFD)-based, edition (*AASHTO 1997*). An evaluation of available foreign specifications covering pedestrian bridges, and failure investigation reports as well as research results related to the behavior and performance of pedestrian bridges was performed during the development of the LRFD Guide Specifications.

C1.2

It is important to clearly delineate the responsibilities of each party when proprietary bridge systems are used. All portions of the design must be supported by sealed calculations, whether from the bridge manufacturer, or the specifying engineer. The interface between the proprietary system and the project-specific substructures and foundations needs careful attention.

C1.3

In most cases increasing vertical clearance is the most cost effective method of risk mitigation.

- Increasing the mass of the superstructure
- Increasing the lateral resistance of the superstructure

2—PHILOSOPHY

Pedestrian bridges shall be designed for specified limit states to achieve the objectives of safety, serviceability and constructability, with due regard to issues of inspectability, economy, and aesthetics, as specified in the *AASHTO LRFD*. These Guide Specifications are based on the LRFD philosophy. Mixing provisions from specifications other than those referenced herein, even if LRFD based, should be avoided.

3—LOADS

3.1—PEDESTRIAN LOADING (PL)

Pedestrian bridges shall be designed for a uniform pedestrian loading of 90 psf. This loading shall be patterned to produce the maximum load effects in accordance with *AASHTO LRFD* Article 3.4. Consideration of dynamic load allowance is not required with this loading.

C3.1

The previous edition of these Guide Specifications used a base nominal loading of 85 psf, reducible to 65 psf based on influence area for the pedestrian load. With the LFD load factors, this results in factored loads of $2.17(85) = 184$ psf and $2.17(65) = 141$ psf. The Fourth Edition of *AASHTO LRFD* specified a constant 85 psf regardless of influence area. Multiplying by the load factor, this results in $1.75(85) = 149$ psf. This falls within the range of the previous factored loading, albeit toward the lower end.

European codes appear to start with a higher nominal load (approx 105 psf), but then allow reductions based on loaded length. Additionally, the load factor applied is 1.5, resulting in a maximum factored load of $(1.5)105 = 158$ psf. For a long loaded length, this load can be reduced to as low as 50 psf, resulting in a factored load of $(1.5)50 = 75$ psf. The effect of resistance factors has not been accounted for in the above discussion of the European codes. There are, however, warnings to the designer that a reduction in the load based on loaded length may not be appropriate for structures likely to see significant crowd loadings, such as bridges near stadiums.

Consideration might be given to the maximum credible pedestrian loading. There is a physical limit on how much load can be applied to a bridge from the static weight of pedestrians. It appears that this load is around 150 psf, based on work done by Nowak (2000) from where Figures C1 through C3 were taken. Although there does not appear to be any available information relating to the probabilistic distribution of pedestrian live loading, knowing the maximum credible load helps to define the limits of the upper tail of the distribution of load. The use of a 90 psf nominal live load in combination with a load factor of 1.75 results in a loading of 158 psf, which provides a marginal, but sufficient,

reserve compared with the maximum credible load of 150 psf.



Figure C3.1-1—Live Load of 50 psf



Figure C3.1-2—Live Load of 100 psf



Figure C3.1-3—Live Load of 150 psf

3.2—VEHICLE LOAD (LL)

Where vehicular access is not prevented by fixed

C3.2

The vehicle loading specified are equivalent to the

physical methods, pedestrian bridges shall be designed for a maintenance vehicle load specified in Figure 1 and Table 1 for the Strength I Load Combination unless otherwise specified by the Owner. A single truck shall be placed to produce the maximum load effects and shall not be placed in combinations with the pedestrian load. The dynamic load allowance need not be considered for this loading.

H-trucks shown in Article 3.6.1.6 of *AASHTO LRFD* at the time of this writing (2009) and contained in previous versions of the *AASHTO Standard Specifications for Highway Bridges*.

Table 3.2-1—Design Vehicle

Clear Deck With	Design Vehicle
7 to 10 feet	H5
Over 10 feet	H10

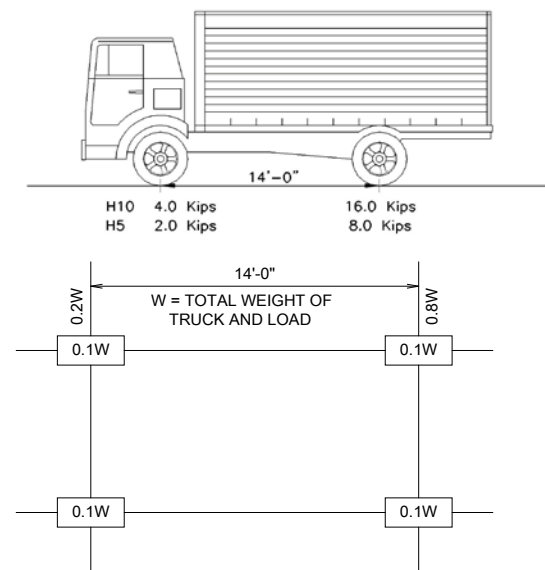

Figure 3.2-1—Maintenance Vehicle Configurations.

3.3—EQUESTRIAN LOAD (LL)

Decks intended to carry equestrian loading shall be designed for a patch load of 1.00 kips over a square area measuring 4.0 inches on a side.

C3.3

The equestrian load is a live load and intended to ensure adequate punching shear capacity of pedestrian bridge decks where horses are expected. The loading was derived from hoof pressure measurements reported in Roland et. al. (2005). The worst loading occurs during a canter where the loading on one hoof approaches 100% of the total weight of the horse. The total factored load of 1.75 kips is approximately the maximum credible weight of a draft horse.

3.4—WIND LOAD (WS)

Pedestrian bridges shall be designed for wind loads as specified in the *AASHTO Signs*, Articles 3.8 and 3.9. Unless otherwise directed by the Owner, the Wind Importance Factor, I_r , shall be taken as 1.15. The

C3.4

The wind loading is taken from *AASHTO Signs* specification rather than from *AASHTO LRFD* due to the potentially flexible nature of pedestrian bridges, and also due to the potential for traffic signs to be mounted on

loading shall be applied over the exposed area in front elevation including enclosures. Wind load on signs supported by the pedestrian bridge shall be included.

In addition to the wind load specified above, a vertical uplift line load as specified in AASHTO LRFD Article 3.8.2 and determined as the force caused by a pressure of 0.020 ksf over the full deck width, shall be applied concurrently. This loading shall be applied at the windward quarter point of the deck width.

3.5—FATIGUE LOAD (LL)

The fatigue loading used for the fatigue and fracture limit state (Fatigue I) shall be as specified in Section 11 of the *AASHTO Signs*. The Natural Wind Gust specified in Article 11.7.3 and the Truck-Induced Gust specified in Article 11.7.4 of that specification need only be considered, as appropriate.

3.6—APPLICATION OF LOADS

When determining the pattern of pedestrian live loading which maximizes or minimizes the load effect on a given member, the least dimension of the loaded area shall be greater than or equal to 2.0 ft.

3.7—COMBINATION OF LOADS

The types of bridges identified in Article 1.1 shall be designed for the load combinations and load factors specified in AASHTO LRFD Table 3.4.1-1, with the following exceptions:

- Load combinations Strength II, Strength IV, and Strength V need not be considered.
- The load factor for the Fatigue I load combination shall be taken as 1.0, and the Fatigue II load combination need not be considered.

4—FATIGUE

4.1—RESISTANCE

The fatigue resistance for steel components and details shall be as specified in the *AASHTO LRFD*,

them.

For porous wind enclosures, the wind pressure may be reduced but pressures less than 85% of the pressure on a solid enclosure are not recommended.

C3.5

For vehicular bridges, wind loads are not part of the Fatigue I load combination. Note that since this article designates wind as a live load for pedestrian bridges, via the designation LL, this confirms that wind should be considered a fatigue live load.

Neither the pedestrian live load nor the maintenance vehicle load used for strength and serviceability is appropriate as a fatigue design loading due to the very infrequent nature of this loading. The fatigue loading specified is consistent with the treatment of sign support structures. For bridges crossing roadways, the truck-induced gust loading should be considered. The other loadings specified in *AASHTO Signs* are not applicable to pedestrian bridges due to their decreased susceptibility to galloping or vortex shedding vibrations.

C3.6

The dimension given is meant to represent a single line of pedestrians; any width less than this would not represent a practical loading scenario.

C3.7

Load combination Strength II is meant for special permit trucks, which is not applicable to pedestrian bridges. Strength IV is for dead load dominant structures such as long span trusses, and would not likely apply to pedestrian bridges. Strength V addresses the case of strong wind combined with reduced live loading, which is not likely to occur for pedestrian bridges. For unusual cases where the excluded load combinations have a reasonable chance of occurring, they should be considered in the design. The fatigue loading specified in *AASHTO Signs* and referenced herein was calibrated for a load factor of 1.0 and the design condition of infinite life.

Article 6.6.1.2.5 for the Fatigue I load combination. For those components and details not covered in *AASHTO LRFD*, the nominal fatigue resistance may be taken from Table 11.3 of *AASHTO Signs* or Figure 2.13 of *AWS D1.1 Structural Welding Code – Steel*.

The fatigue resistance for steel reinforcement in concrete structures shall be as specified in the *AASHTO LRFD* Article 5.5.3.

4.2—FRACTURE

Except as specified herein, all of the provisions specified in Article 6.6.2 of the *AASHTO LRFD* relating to Charpy V-notch (CVN) fracture toughness requirements, including Fracture Critical Member (FCM) and Main Member designation, shall apply to steel pedestrian bridges. Design of tubular members shall also satisfy the provisions of Article 8.2. If supported by the characteristics of the site and application, the Owner may waive the FCM requirements.

5—DEFLECTIONS

Deflections should be investigated at the service limit state using load combination Service I in Table 3.4.1-1 of *AASHTO LRFD*. For spans other than cantilever arms, the deflection of the bridge due to the unfactored pedestrian live loading shall not exceed 1/500 of the span length. Deflection in cantilever arms due to the pedestrian live loading shall not exceed 1/300 of the cantilever length. Horizontal deflections under unfactored wind loading shall not exceed 1/500 of the span length.

6—VIBRATIONS

Vibrations shall be investigated as a service limit state using load combination Service I in Table 3.4.1-1 of *AASHTO LRFD*. Vibration of the structure shall not cause discomfort or concern to users of a pedestrian bridge. Except as specified herein, the fundamental frequency in a vertical mode of the pedestrian bridge without live load shall be greater than 3.0 hertz (Hz) to avoid the first harmonic. In the lateral direction, the fundamental frequency of the pedestrian bridge shall be greater than 1.3 Hz. If the fundamental frequency cannot satisfy these limitations, or if the second harmonic is a concern, an evaluation of the dynamic performance shall be made. This evaluation shall consider:

- The frequency and magnitude of pedestrian footfall loadings
- The phasing of loading from multiple

C4.2

For pedestrian bridges crossing waterways, low-volume traffic, or areas not accessible to the general public, FCM treatment may not be appropriate.

C6

Due to the vibration problems experienced in London on the Millennium bridge, there have been many publications in the technical literature, primarily in Europe, on this topic. Despite this large body of knowledge, it does not appear there has been convergence toward one method of evaluation, or development of any specification that adequately covers this issue.

These provisions address the issue of vibration from two directions: maintaining a minimum natural vibration frequency above those induced by pedestrians, and specifying a minimum weight to limit vibration amplitudes if the frequency limits are not met. Although somewhat outdated, both of these approaches are still viable and have the great advantage of simplicity.

The technical guide published by Setra (Service d'Etudes Techniques des Routes et Autoroutes) (2006) appears to present a relatively straightforward method for addressing vibration issues when the frequencies of the bridge fall within the pacing frequencies of pedestrians.

pedestrians on the bridge at the same time, including the “lock-in” phenomena

- Appropriate estimation of structural damping
- Frequency dependent limits on acceleration and/or velocity

In lieu of such evaluation in the vertical direction the bridge may be proportioned such that either of the following criteria are satisfied:

$$f \geq 2.86 \ln \left(\frac{180}{W} \right) \quad (6-1)$$

or

$$W \geq 180 e^{(-0.35f)} \quad (6-2)$$

where:

W = the weight of the supported structure, including only dead load (kip)

f = the fundamental frequency in the vertical direction (Hz)

7—STABILITY

7.1—HALF-THROUGH TRUSSES

7.1.1—Lateral Frame Design Force

The vertical truss members, the floor beams and their connections shall be proportioned to resist a lateral force applied at the top of the truss verticals. The lateral force shall not be less than 0.01/K times the average factored design compressive force in the two adjacent top chord members, where K is the design effective length factor for the individual top chord members supported between the truss verticals. In no case shall the value for 0.01/K be less than 0.003 when determining the minimum lateral force, regardless of the K-value used to determine the compressive capacity of the top chord. The lateral frame design force shall be applied concurrently with the loading used to determine the average compressive force above.

End posts shall be designed as a simple cantilever to carry its applied axial load combined with a lateral load of 1.0% of the end post axial load, applied laterally at the upper end.

7.1.2—Top Chord Stability

The top chord shall be considered as a column with elastic lateral supports at the panel points. The

The “lock-in” phenomenon refers to the tendency of people to synchronize their pacing frequency to the lateral frequency of the bridge when the lateral displacements begin to grow. In other words, instead of random frequencies and phasing among the loading from pedestrians on the bridge, the frequencies and phases becomes fully correlated with the bridge motion.

C7.1.1

This article modifies the provisions of *AASHTO LRFD* by replacing the 300 pounds per linear foot design requirements for truss verticals with provisions based on research reported in Galambos (1998). These provisions establish the minimum lateral strength of the verticals based on the degree of lateral support necessary for the top chord to resist the maximum design compressive force.

C7.1.2

The use of the 1.33 factor applied to the factored compression load to determine P_c is in recognition that

contribution of the connection stiffness between the floor beam and the vertical member shall be considered in determining the stiffness of the elastic lateral supports.

The procedure for determining the resistance of a compression member in *AASHTO LRFD* may be used to determine the resistance of the compression chord with a value for the effective length factor, K , obtained from Table 1. In this table,

C = stiffness of the lateral U-frame made of the truss verticals and the floorbeam taken as P/Δ (kip/in.)

P = arbitrary lateral load as shown schematically in Figure 1 (kips)

Δ = lateral deflection resulting from lateral load P and shown schematically in Figure 1 (in.)

L = length of the chord between panel points (in.)

P_c = desired critical buckling load (kip), which shall be taken as 1.33 times the factored compressive load,

n = number of panels in the truss

Figure 1 shows schematically a lateral U-frame. C would be calculated as P/Δ .

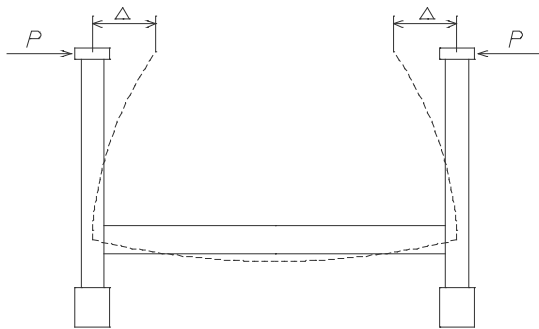

Figure 7.1.2-1—Lateral U-Frame

for uniformly loaded structures there is a higher probability of the maximum compression force occurring simultaneously in adjacent truss panels. For further discussion refer to Galambos (1998).

Interpolation of values between those given in the table is acceptable.

Table 7.1.2-1—Values of 1/K for various Values of CL/Pc and n

1/K	n=4	n=6	n=8	n=10	n=12	n=14	n=16
1.000	3.686	3.616	3.660	3.714	3.754	3.785	3.809
0.980		3.284	2.944	2.806	2.787	2.771	2.774
0.960		3.000	2.665	2.542	2.456	2.454	2.479
0.950			2.595				
0.940		2.754		2.303	2.252	2.254	2.282
0.920		2.643		2.146	2.094	2.101	2.121
0.900	3.352	2.593	2.263	2.045	1.951	1.968	1.981
0.850		2.460	2.013	1.794	1.709	1.681	1.694
0.800	2.961	2.313	1.889	1.629	1.480	1.456	1.465
0.750		2.147	1.750	1.501	1.344	1.273	1.262
0.700	2.448	1.955	1.595	1.359	1.200	1.111	1.088
0.650		1.739	1.442	1.236	1.087	0.988	0.940
0.600	2.035	1.639	1.338	1.133	0.985	0.878	0.808
0.550		1.517	1.211	1.007	0.860	0.768	0.708
0.500	1.750	1.362	1.047	0.847	0.750	0.668	0.600
0.450		1.158	0.829	0.714	0.624	0.537	0.500
0.400	1.232	0.886	0.627	0.555	0.454	0.428	0.383
0.350		0.530	0.434	0.352	0.323	0.292	0.280
0.300	0.121	0.187	0.249	0.170	0.203	0.183	0.187
0.293	0						
0.259		0					
0.250			0.135	0.107	0.103	0.121	0.112
0.200			0.045	0.068	0.055	0.053	0.070
0.180			0				
0.150				0.017	0.031	0.029	0.025
0.139				0			
0.114					0		
0.100						0.003	0.010
0.097						0	
0.085							0

7.1.3—Alternative Analysis Procedures

The use of a second-order numerical analysis procedure to evaluate the stability of the top chord of a half-through truss is acceptable in lieu of the procedure above, provided the following aspects are included in the model:

- Effects of initial out-of-straightness, both between panel points and across the entire length of the compression chord
- Effects of residual stresses in compression members due to fabrication and construction
- Effects of the stiffness of vertical to floorbeam connections

C7.1.3

Given the increasing availability of software that is capable of second order analyses, such an analysis is a practical alternative to the method given in Article 7.1.2. However, the design equations in *AASHTO LRFD* account for the issues identified, and any alternative method should also address these. One method that might be followed would be to use the second order numerical analysis to determine the K factor for a given chord size and panel point frame stiffness, and then the design equations of *AASHTO LRFD* to determine the corresponding resistance.

7.2—STEEL TWIN I-GIRDER AND SINGLE TUB GIRDER SYSTEMS

7.2.1—General

For potentially torsionally flexible systems such as twin I-girder and single tub girder structural systems, the designer shall consider:

- The out-of-plane stiffness of twin I-girders, prior becoming composite with a concrete deck, can be significantly smaller than the in-plane, or vertical, stiffness. This can lead to a lateral-torsional buckling instability during construction
- Single tub girders, prior to becoming composite with a concrete deck, behave as singly symmetric sections with a shear center below the bottom flange. *AASHTO LRFD* Article 6.7.5.3 requires top lateral bracing in tub section members to prevent lateral torsional buckling of these sections.
- Prior to becoming composite with a concrete deck, twin I-girders with bottom flange bracing, will behave as a tub girder and exhibit the same tendencies toward lateral-torsional buckling. Top lateral bracing shall be provided as for tub sections, or the stability shall be checked as a singly symmetric member.

7.2.2—Lateral Torsional Buckling Resistance - Twin I-Girder

For evaluating the stability of twin I-girder systems without a composite deck or lateral bracing, the equation given by Yura and Widiyanto (2005) may be used:

$$M_n = M_{cr} = \frac{\pi^2 S E}{L^2} \sqrt{I_{yo} I_{xo}} \leq M_{px} \quad (7.2.2-1)$$

where:

- E = modulus of elasticity of steel (ksi)
- I_{xo} = in-plane moment of inertia of one girder (in.⁴)
- I_{yo} = out-of-plane moment of inertia of one girder (in.⁴)
- L = effective buckling length for lateral-torsional buckling (ft)
- M_{cr} = critical elastic lateral torsional buckling

C7.2.1

Several incidents have highlighted the need for a careful evaluation of the stability of pedestrian bridges, especially during the construction stages. Structural systems consisting of two parallel girders can exhibit very different behavior during construction depending on the bracing systems used. If no lateral bracing is present, during construction the out-of-plane (transverse) bending stiffness can be much less than the in-plane (vertical) stiffness and lateral-torsional buckling can occur. After the deck is cast, the section is effectively a “c” shape, which is singly symmetrical. Use of the appropriate lateral-torsional buckling equation is critical, and reference should be made to Galambos (1998). Further information is contained in Yura and Widiyanto (2005), as well as Kozy and Tunstall (2007).

	moment of one girder (kip-in.)
M_{px} =	in-plane plastic moment of one girder (kip-in.)
M_r =	nominal in-plane flexural resistance of one girder (kip-in.)
S =	spacing between girders (in.)

Where a concrete deck is used, continuous twin I-girder systems shall be made composite with the deck for the entire length of the bridge.

7.2.3—Lateral-Torsional Buckling Resistance-Singly Symmetric Sections

The lateral-torsional stability of singly symmetric sections not covered in Article 7.2.2 shall be investigated using information available in the literature.

C7.2.3

Equations for the determination of the lateral-torsional buckling moment in singly symmetric sections are given in the “Guide to Stability Design Criteria for Metal Structures” by Galambos (1998), specifically in chapter 5. Equation 5.9 of that chapter presents the general formula for bending members. Methods for accounting for location of loading with respect to the shear center are provided, as well as for determining the appropriate buckling lengths considering rotational restraints.

8—TYPE SPECIFIC PROVISIONS

8.1—ARCHES

Arches shall be designed in accordance with the provisions of the *AASHTO LRFD* with guidance from Nettleton (1977).

8.2—STEEL TUBULAR MEMBERS

8.2.1—General

The capacities and resistances for the design of connections for welded tubular steel members shall be in accordance with the Chapter K of the specifications and commentary of AISC (2005) or *AASHTO Signs*. Resistances for fatigue design shall be in accordance with the Structural Welding Code – Steel ANSI/AWS D1.1 Section 2.20.6 or Section 11 of *AASHTO Signs*. All loads, load factors, and resistance factors shall be as specified by *AASHTO LRFD* and these Guide Specifications. For member design other than connections:

- Flexure resistance of rectangular tubular members shall be according to *AASHTO LRFD* Article 6.12 as box sections.
- Shear resistance of rectangular tubular members shall be according to *AASHTO LRFD* Article 6.11.9 as box sections.

- Tension and compression resistance shall be according to *AASHTO LRFD* Article 6.8.2 and 6.9.2, respectively.

For electric-resistance-welded tubular members, the design wall thickness shall be taken as 0.93 times the nominal wall thickness.

8.2.2—Detailing

The minimum metal thickness of closed structural tubular members shall be 0.25 inch. These members shall either be completely sealed to the atmosphere, or be hot-dipped galvanized and provided with drain holes.

8.2.3—Tubular Fracture Critical Members

The AASHTO/AWS Fracture Control Plan for Nonredundant Members contained in AASHTO/AWS D1.5, Section 12, shall be applied to tubular members, where required by *AASHTO LRFD* Articles 6.6.2 and C6.6.2, with the following modifications:

- ASTM A500, A501, A847, and A618 shall be added to those listed in Article 12.4.1
- For the purposes of determining preheat and interpass temperatures, the values for A709 Grade 50 shall be used.
- Steel for tubular sections shall conform to the Charpy v-notch requirements defined in A709-07. Filler metal shall be treated as A709 and conform to the requirements of AWS D1.5 Table 12.1.
- Welding details for cyclically loaded tubular members specified by AASHTO/AWS D1.1 shall be used.
- All welds require qualification using AWS D1.1 Figure 4.8.

C8.2.2

Different philosophies exist on how best to protect tubular members from corrosion. One method is to completely seal the interior of the member from the atmosphere. This requires careful detailing of the connections, as even a small opening will allow moisture laden air into the interior, and over time this can result in a large accumulation of water. Box members in a large truss that were supposedly sealed to the atmosphere have been found to contain several feet of water.

Another method of corrosion protection is to vent the interior of the tube adequately and to provide some form of surface treatment, often a galvanized finish, to prevent corrosion. Issues to consider include the size of the field pieces to be galvanized, the size of local galvanizing kettles, and the service environment of the bridge.

FHWA Technical Advisory T 5140.22 (1989) provides guidance in the use of weathering steels.

C8.2.3

No current specification adequately covers the use of tubular members in a fracture critical capacity. AASHTO/AWS D1.5 specifically excludes tubular members. It appears significant research is required to address the unique aspects of both the longitudinal weld used to create the closed shape, as well as the one-sided groove welds without backing bars used in the connections of HSS. Until such time as this research is performed, the procedure specified herein represents the best available method for addressing fracture critical issues in HSS construction.

8.3—FIBER REINFORCED POLYMER (FRP) MEMBERS

The minimum thickness of closed structural FRP members (such as tubes) shall be 0.25 inch. The minimum thickness of open structural FRP members (such as channels) including connection plates shall be 0.375 inch.

C8.3

For design of FRP members in pedestrian bridges, reference may be made to the *AASHTO Guide Specifications for Design of FRP Pedestrian Bridges (2008)*. Little information is currently available regarding resistance equations or resistance factors for this material used in bridge structures. Several design specifications covering FRP pultruded shapes are currently under development by the American Society of Civil Engineers and may be of use in the future for the design of FRP pedestrian bridges.

REFERENCES

AASHTO. 1997. *Guide Specifications for Design of Pedestrian Bridges*, American Association of State Highway and Transportation Officials, Washington, DC.

AASHTO. 2001. *Standard Specifications for Structural Supports for Highway Signs, Luminaries and Traffic Signals*, 4th Edition, LTS-4, American Association of State Highway and Transportation Officials, Washington, DC.

AASHTO. 2002. *Standard Specifications for Highway Bridges*, 17th Edition, American Association of State Highway and Transportation Officials, Washington, DC.

AASHTO. 2007. *AASHTO LRFD Bridge Design Specifications*, 4th Edition, 2008 and 2009 Interim, American Association of State Highway and Transportation Officials, Washington, DC.

AASHTO. 2008. *AASHTO Guide Specifications for Design of FRP Pedestrian Bridges*, 1st Edition, American Association of State Highway and Transportation Officials, Washington, DC.

AISC. 2005. *Specification for Structural Steel Buildings*, ANSI/AISC 360-05, American Institute of Steel Construction, Chicago, IL.

Allen, D. E. and Murray, T. M. 1993 "Design Criterion for Vibrations Due to Walking," *AISC Journal*, 4th Quarter, pp. 117-129.

AWS. 2008. *Bridge Welding Code*, AASHTO/AWS D1.5M/D1.5:2008, American Welding Society, Miami, FL.

AWS. 2006. *Structural Welding Code - Steel*, AASHTO/AWS D1.1M/D1.1M:2006, American Welding Society, Miami, FL.

Bachmann, H. "Lively footbridges - a real challenge". *Proceedings of the International Conference on the Design and Dynamic Behavior of Footbridges*, Paris, France, November 20–22, 2002, pp.18–30.

Blekherman, A.N. 2007 "Autoparametric Resonance in a Pedestrian Steel Arch Bridge: Solferino Bridge, Paris," *Journal of Bridge Engineering*, Volume 12, Issue 6, pp. 669-676

Dallard, P., Fitzpatrick, T., Flint A., Low A., Smith R.R., Willford M., and Roche M. "London Millennium Bridge: Pedestrian-Induced Lateral Vibration". *Journal of Bridge Engineering*, Volume 6, Issue 6, 2001, pp. 412-417.

Dallard, P., et al. "The London Millennium Footbridge". *Structural Engineering*, 79(22), 2001, pp.17–33.

FHWA, 1989. *Uncoated Weathering Steel in Structures*, Technical Advisory T 5140.22, Federal Highway Administration, US Department of Transportation, Washington, DC.

Galambos, T.V. 1998. *Guide to Stability Design Criteria for Metal Structures*, 5th Edition, John Wiley & Sons, Inc., New York, NY

Kozy, B. and Tunstall, S. 2007 "Stability Analysis and Bracing for System Buckling in Twin I-Girder Bridges," *Bridge Structures: Assessment, Design and Construction*, Vol 3 No.3-4, pp 149-163

Nettleton, D. A. 1977. *Arch Bridges*, Bridge Division, Office of Engineering, Federal Highway Administration, U.S. Department of Transportation, Washington, DC.

Nowak, A.S. and Collins, K.R. 2000. *Reliability of Structures*, McGraw-Hill International Editions, Civil Engineering Series, Singapore,

Poston, Randall W., West, Jeffery S. "Investigation of the Charlotte Motor Speedway Bridge Collapse," *Metropolis & Beyond 2005 - Proceedings of the 2005 Structures Congress and the 2005 Forensic Engineering Symposium*, April 20-24, 2005, New York, NY, ASCE

Roberts, T. M. 2005 "Lateral Pedestrian Excitation of Footbridges," *Journal of Bridge Engineering*, Volume 10, Issue 1, pp. 107-112.

Roland, E. S., Hull, M. L., and Stover, S. M. 2005. "Design and Demonstration of a Dynamometric Horseshoe for Measuring Ground Reaction Loads of Horses during Racing Conditions," *Journal of Biomechanics*, Vol. 38, No. 10, pp. 2102-2112.

SETRA. 2006. *Technical Guide – Footbridges -Assessment of Vibrational Behaviour of Footbridges under Pedestrian Loading*, Service d'Etudes Techniques des Routes et Autoroutes, Association Francaise De Genie Civil, Paris, France.

Willford, M. "Dynamic actions and reactions of pedestrians". *Proceedings of the International Conference on the Design and Dynamic Behavior of Footbridges*, Paris, France, November 20–22, 2002.

Yura, J. A. and Widiyanto. 2005. "Lateral Buckling and Bracing of Beam – A Re-evaluation after the Marcy Bridge Collapse." *2005 Annual Technical Session Proceedings*, April 6-9, 2005 in Monreal, Quebec, Canada, Structural Stability Research Council. Rolla, MO.

Zivanovic, S., Pavic, A., and Reynolds, P. "Vibration serviceability of footbridges under human-induced excitation: a literature review". *Journal of Sound and Vibration*, 279(1-2), 2005, pp. 1-74.