



SCAN TEAM REPORT

NCHRP Project 20-68A, Scan 11-02

Best Practices Regarding Performance of ABC Connections in Bridges Subjected to Multihazard and Extreme Events

Supported by the

National Cooperative Highway Research Program

The information contained in this report was prepared as part of NCHRP Project 20-68A U.S. Domestic Scan, National Cooperative Highway Research Program.

SPECIAL NOTE: This report IS NOT an official publication of the National Cooperative Highway Research Program, Transportation Research Board, National Research Council, or The National Academies.



Acknowledgments

The work described in this document was conducted as part of NCHRP Project 20-68A, the U.S. Domestic Scan program. This program was requested by the American Association of State Highway and Transportation Officials (AASHTO), with funding provided through the National Cooperative Highway Research Program (NCHRP). The NCHRP is supported by annual voluntary contributions from the state departments of transportation. Additional support for selected scans is provided by the U.S. Federal Highway Administration and other agencies.

The purpose of each scan and of Project 20-68A as a whole is to accelerate beneficial innovation by facilitating information sharing and technology exchange among the states and other transportation agencies, and identifying actionable items of common interest. Experience has shown that personal contact with new ideas and their application is a particularly valuable means for such sharing and exchange. A scan entails peer-to-peer discussions between practitioners who have implemented new practices and others who are able to disseminate knowledge of these new practices and their possible benefits to a broad audience of other users. Each scan addresses a single technical topic selected by AASHTO and the NCHRP 20-68A Project Panel. Further information on the NCHRP 20-68A U.S. Domestic Scan program is available at <http://144.171.11.40/cmsfeed/TRBNetProjectDisplay.asp?ProjectID=1570>.

This report was prepared by the scan team for Scan 11-02, *Best Practices Regarding Performance of ABC Connections in Bridges Subjected to Multi-Hazard and Extreme Events*, whose members are listed below. Scan planning and logistics are managed by Arora and Associates, P.C.; Harry Capers is the Principal Investigator. NCHRP Project 20-68A is guided by a technical project panel and managed by Andrew C. Lemer, PhD, NCHRP Senior Program Officer.

Jugesh Kapur, Washington State DOT, AASHTO Chair

Alexander Bardow, Massachusetts Highway Department

Waseem Dekelbab, Transportation Research Board, TRB Liaison

Michael Keever, California DOT

M. Saiid Saiidi, University of Nevada, Reno, Subject Matter Expert

Joshua Sletten, Utah DOT

Daniel Tobias, Illinois DOT

W. Phillip Yen, Federal Highway Administration

Disclaimer

The information in this document was taken directly from the submission of the authors. The opinions and conclusions expressed or implied are those of the scan team and are not necessarily those of the Transportation Research Board, the National Research Council, or the program sponsors. This document has not been edited by the Transportation Research Board.

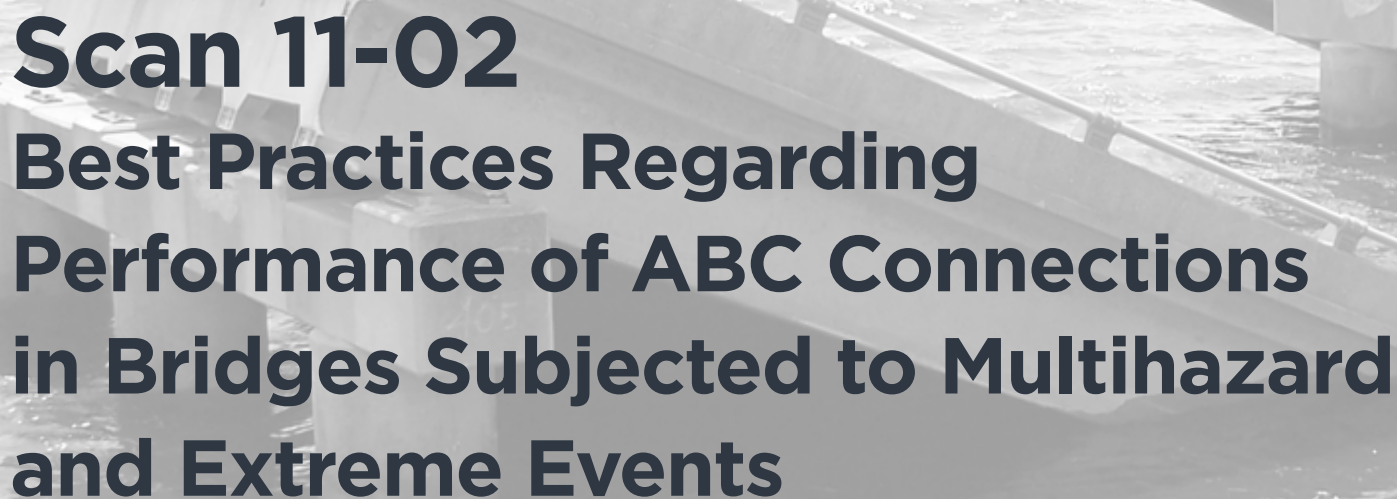

Scan 11-02

Best Practices Regarding Performance of ABC Connections in Bridges Subjected to Multihazard and Extreme Events

REQUESTED BY THE

American Association of State Highway and Transportation Officials

PREPARED BY

Jugesh Kapur,
Washington State DOT, AASHTO Chair

Michael Kever,
California DOT

W. Phillip Yen,
Federal Highway Administration

Joshua Sletten,
Utah DOT

Waseem Dekelbab,
Transportation Research Board, TRB Liaison

Daniel Tobias,
Illinois DOT

Alexander Bardow,
Massachusetts Highway Department

M. Saïid Saïidi,
*University of Nevada, Reno,
Subject Matter Expert*

SCAN MANAGEMENT

Arora and Associates, P.C.
Lawrenceville, NJ

October 2012

The information contained in this report was prepared as part of NCHRP Project 20-68A U.S. Domestic Scan, National Cooperative Highway Research Program.

SPECIAL NOTE: This report IS NOT an official publication of the National Cooperative Highway Research Program, Transportation Research Board, National Research Council, or The National Academies.

TABLE OF CONTENTS

Table of Contents

Abbreviations and Acronyms	VI
---	-----------

Executive Summary.....	ES-1
-------------------------------	-------------

Introduction	ES-1
Scan Purpose and Scope.....	ES-1
General Findings and Observations.....	ES-2
Extreme Load Consideration for Bridges and ABC Connections.....	ES-2
ABC Connection Detail.....	ES-3
ABC Connection Maintenance.....	ES-3
Standardization of ABC Connection Details and Processes	ES-4
ABC Connection Research	ES-4
Innovative ABC Connections.....	ES-5
Monitoring ABC Connections and Prefabricated Bridge Elements and Systems	ES-5
Other Findings	ES-5
Recommendations.....	ES-6

1.0 Introduction.....	1-1
------------------------------	------------

Background.....	1-1
Objectives, Purpose, and Scope.....	1-1
Scan Team and Participants.....	1-1
Scan Team	1-3
Scan Participants	1-3
Scan Approach and Planning.....	1-5
Develop Preliminary Amplifying Questions	1-5
Conduct Desk Scan	1-5
Hold an Organizational Meeting of the Scan Team.....	1-10

2.0 Scan Findings and Observations	2-1
---	------------

Primary Findings	2-1
------------------------	-----

Extreme Load Consideration for Bridges and ABC Connections	2-1
ABC Connection Details	2-14
ABC Connection Maintenance	2-18
Standardization of ABC Connection Details and Processes	2-19
ABC Connection Research	2-22
Innovative ABC Connections.....	2-32
Monitoring ABC Connections and Prefabricated Bridge Elements and Systems ..	2-33
Other Findings	2-34
3.0 Recommendations	3-1
Continue Research on MH Load Combination and the Effects of Extreme Loads on ABC Connections	3-1
Establish a National Center on MH Design of ABC Bridges.....	3-1
Establish Ongoing Communication to The Associated General Contractors of America and other ABC Stakeholders	3-2
Expand FHWA HfL and IBRD Programs	3-2
Expand Research on Emulative ABC Connections Under Extreme Loads	3-3
Support Research on ABC Connections with Unconventional Materials	3-3
Collect, Organize, and Disseminate Field Data on ABC Connections	3-3
Expand AASHTO Seismic Guide Specifications for Implementation of ABC.....	3-3
Perform Research on High-Early-Strength Concrete and Grouts and Develop Design and Construction Specifications	3-4
Develop Guidelines for Shipment and Erection of Prefabricated Components.....	3-4
4.0 Implementation Plan	4-1

List of Appendices

Appendix A: Scan Team Contact Information.....	A-1
Appendix B: Scan Team Biographical Sketches.....	B-1
Appendix C: Host Agency Key Contacts	C-1
Appendix D: Amplifying Questions.....	D-1

List of Figures

Figure 2.1	Survey results for consideration of three concurrent extreme events (i.e., scour, storm surge, and wind) ⁵⁰	2-2
Figure 2.2	Survey results for consideration of cascading events ⁵⁰	2-2
Figure 2.3	Full-depth precast concrete deck panel longitudinal connection	2-4
Figure 2.4	Precast box beam connection over pier cap	2-5
Figure 2.5	Precast column to cast-in-place cap beam connection	2-5
Figure 2.6	Precast girder to abutment connection	2-6
Figure 2.7	Precast column to precast pier cap connection	2-6
Figure 2.8	Segmental precast column connections	2-7
Figure 2.9	Precast footing to precast footing connection	2-7
Figure 2.10	Full-depth precast deck panel with shear pockets for connection to girders	2-8
Figure 2.11	Shear pockets details for full-depth precast deck panel	2-9
Figure 2.12	Full-depth precast deck panel connection	2-9
Figure 2.13	Deck closure pour construction in Massachusetts Fast 14	2-10
Figure 2.14	Deck post-tensioning in Utah	2-10
Figure 2.15	Precast column to CIP footing connection in Washington State	2-11
Figure 2.16	Precast column to precast footing connection in a UNR study	2-11
Figure 2.17	Precast column to precast shaft connection with CIP sleeve in Washington State	2-12
Figure 2.18	Precast pile to CIP cap beam connection in South Carolina	2-12
Figure 2.19	Precast abutment wall and footings with grouted coupler connections in Massachusetts	2-13
Figure 2.20	Precast column pier cap connection with grouted coupler in Florida	2-13
Figure 2.21	Grouted coupler as continuity splice over pier in Massachusetts	2-13
Figure 2.22	Precast column connection to pile shaft with embedded grouted coupler in Utah	2-14
Figure 2.23	Corrugated ducts in precast cap beam in Washington State	2-15
Figure 2.24	Placement of cap beam on column bars inserted in corrugated ducts in Washington State	2-15
Figure 2.25	UNR test model with corrugated ducts in footing	2-15
Figure 2.26	Elevation of UNR test model with HPC grout in ducts	2-16
Figure 2.27	Precast abutment wall segments with embedded corrugated pipes	2-16

LIST OF FIGURES

Figure 2.28	Precast abutment end diaphragm bolted connection in Utah	2-17
Figure 2.29	Segmental cap beam/pier system in Florida	2-18
Figure 2.30	Utah manual and design guide on SPMT moves	2-20
Figure 2.31	Cap beam-column connection used in Massachusetts	2-20
Figure 2.32	Decision criteria hierarchy	2-21
Figure 2.33	Full-depth deck slab connection model tested at the FDOT Testing Structure Research Center	2-22
Figure 2.34	Model of a precast column model embedded in CIP footing at the University of Washington	2-23
Figure 2.35	Plastic hinge in precast column embedded in CIP footing	2-24
Figure 2.36	Pile cap beam connection model tested at the University of South Carolina	
Figure 2.37	Column-cap beam connection with large diameter concept	2-24
Figure 2.38	Column cap beam connection tested at the University of Washington	2-25
Figure 2.39	Precast column-footing connection model with headed bar couplers tested at UNR	2-25
Figure 2.40	Precast column-footing connection model with grouted couplers tested at UNR	2-26
Figure 2.41	Damage at 5% drift ratio for models tested at UNR (left to right: CIP, headed bar couplers, and grouted couplers)	2-27
Figure 2.42	ISU superstructure/cap beam connection with unstressed post-tensioned tendon	2-27
Figure 2.43	ISU superstructure/cap beam connection with high-strength bars	2-28
Figure 2.44	Segmental column connection with sliding joints tested at SUNY Buffalo	2-28
Figure 2.45	Segmental column model with CIP base segment on a shake table at UNR	2-29
Figure 2.46	Details of rubber pad incorporated into a segmental column model at UNR	2-29
Figure 2.47	Segmental column model with rubber pad a shake table at UNR	2-29
Figure 2.48	Precast concrete-filled FRP tube column at UNR	2-30
Figure 2.49	Concrete-filled steel tube column model tested at the University of Washington	2-31
Figure 2.50	Steel pipe pin connection in a concrete-filled FRP tube column at UNR	2-31
Figure 2.51	Lowering a precast cap beam onto steel pipe pin connections of a concrete-filled FRP tube pier at UNR	2-31
Figure 2.52	Concrete-filled carbon-fiber-reinforced polymer tube arches implemented in a bridge in Massachusetts	2-32
Figure 2.53	NEXT double-T girder used in Massachusetts	2-33
Figure 2.54	Folded plate girder bridge in Massachusetts	2-34

List of Tables

Table 1.1	Scan Team Members.....	1-2
Table 1.2	Location and Activities of Week 1 Scan.....	1-3
Table 1.3	Location and Activities of Week 2 Scan.....	1-4

Abbreviations and Acronyms

AASHTO	American Association of State Highway and Transportation Officials
ABC	Accelerated Bridge Construction
Caltrans	California Department of Transportation
CIP	Cast in Place
DOT	Department of Transportation
FDOT	Florida Department of Transportation
FHWA	Federal Highway Administration
FRP	Fiber-Reinforced Polymer
IBRD	Innovative Bridge Research and Deployment (FHWA)
HfL	Highways for LIFE (FHWA)
LRFD	Load and Resistance Factor Design
MassDOT	Massachusetts Highway Department
MH	Multi-Hazard
NCHRP	National Cooperative Highway Research Program
NEXT	Northeast Extreme Tee
SDC	Seismic Design Category
SPMT	Self-Propelled Modular Transporter
SME	Subject Matter Expert
SUNY	State University of New York
TRB	Transportation Research Board
UNR	University of Nevada, Reno

Executive Summary

Introduction

The National Cooperative Highway Research Program (NCHRP) Project No. 20-68A, U.S. Domestic Scan Program, is a broad initiative that considers innovative transportation-related practices used by some transportation agencies and potentially could be adopted by other agencies to help advance their own state-of-the-practice. The purpose of the scan program is to collect and facilitate sharing of information and technology among the states and other transportation agencies and identify actionable items related to the dissemination of the findings and the implementation of the best practices identified in the scan.

One of the innovative practices a number of states use is accelerated bridge construction (ABC), which is intended to reduce the time and overall costs of bridge construction and its impact on the traveling public and improve work-zone safety, quality, and durability, among other factors. Working more efficiently is consistent with the Federal Highway Administration's (FHWA's) Every Day Counts initiative.

ABC practices often involve using prefabricated components that must be connected effectively to form a well-integrated bridge system that resists design loads. Connections of prefabricated elements are particularly critical under extreme event loading, such as high waves, tidal or storm surges, earthquakes, high winds, blasts, and other largely lateral forces acting on bridges. This scan focused on connections that are resistant to this type of loading.

This report presents a summary of the initial findings, recommendations, and planned implementation actions of a domestic scan conducted from March 25 to 31 and April 22 to 28, 2012, to identify successful and emerging ABC connections that are able to resist multi-hazard (MH) loading and extreme events.

Scan Purpose and Scope

This scan's overall objective was to identify connection details that are used in the United States for ABC and perform well under natural or man-made extreme events, loading (e.g., those under waves and tidal or storm-surges), seismic events, blasts, and other large forces.

A desk scan was conducted prior to the site visits. The desk scan included a brief review of the most relevant reports, papers, and web materials. The main part of the desk scan was an extensive survey of nine states, each with a known interest in ABC, a history of ABC-related activities, and in which one or more extreme event is likely to occur.

The scan team met in Washington, DC, on November 17, 2011, to discuss the desk scan report, which analyzed and summarized the survey's results. In addition to discussing the scan's mission and the site visit schedule, the team also developed a list of amplifying questions and finalized the list of states and institutions to be included in the scan.

The scan team visited Massachusetts, Florida, Utah, Washington State, and Nevada, the first two during the first week of the scan and the latter three during the second week. Several representatives from California joined the scan meeting in Nevada. Texas and South Carolina participated in the meetings in Massachusetts and Florida, respectively via web conference calls. During the team's meeting in Massachusetts, the FHWA-funded State University of New York at Buffalo (SUNY Buffalo) study on MH loading and the seismic performance of segmental bridge members was presented and discussed via a web conference call.

The scan visits consisted of meetings with officials, engineers, contractors, suppliers, and researchers conducting studies of various ABC connections. The team visited select bridge construction sites, completed ABC projects, and research facilities. The findings presented in this report are based on the face-to-face discussions, presentations, responses to amplifying questions, site visits, and supplementary materials that were provided to the scan team.

General Findings and Observations

ABC connection performance under MH loading is a multifaceted subject encompassing many inter-related topics, most of which are emerging. To help identify and communicate the scan results, the team grouped the findings into the following topics:

- Extreme Load Consideration for Bridges and ABC Connections
- ABC Connection Details
- ABC Connection Maintenance
- Standardization of ABC Connection Details and Processes
- ABC Connection Research
- Innovative ABC Connections
- Monitoring ABC Connections and Prefabricated Bridge Elements and Systems
- Other Findings

Extreme Load Consideration for Bridges and ABC Connections

MH loading combinations are considered only to a limited extent even for conventional bridges because of a lack of guidelines and a general belief that the probability of simultaneously occurring multiple extreme loads is low. The team could not identify any information on ABC connection design under MH

loading. Even under seismic loading, no specific American Association of State Highway and Transportation Officials (AASHTO) guidelines exist for ABC connection design, despite the relative maturity of earthquake engineering of bridges. In fact, restrictions on splicing longitudinal column reinforcement within the plastic hinge zone in seismic design category (SDC) C or D in the AASHTO Guide Specifications for LRFD Seismic Bridge Design severely limits the implementation of ABC in high seismic regions. This is consistent with the scan's findings that there is a correlation between the level of seismicity and the level of implementation of ABC practices. The lack of widely accepted, well-developed, and proven ABC connection details has prevented extensive application of ABC in high seismic zones.

An FHWA-funded study is in progress at SUNY Buffalo, to address the gap in knowledge, develop MH design guidelines, and establish a platform to include MH loading in load and resistance factor design (MH-LRFD) for highway bridges. The study's focus is bridges in general; it is not specific to ABC or ABC connections. The study is primarily analytical because of a lack of extensive field and research data. The limit states and load factors developed in this study are aimed for eventual integration in AASHTO LRFD.

ABC Connection Details

Although ABC generally has been applied to a small fraction of the overall bridge population, numerous ABC connection types have been used by various states. Several states have adopted some of the connection details from the FHWA manual on ABC for their ABC practice. Some states allow for unrestrained movement of the superstructure under lateral loads, and the bearing connections are designed for vertical loading only. Under a storm surge, the approach some states take is to allow for uplift of the superstructure.

The scan team identified three types of precast connections during the scan: column to pier cap, column to pile cap, and column to pile shaft. In one connection type, the column is embedded into the adjacent member (i.e., pile shaft, footing, or cap beam). A second connection type consists of grouted couplers that may be embedded into the column or the adjacent member. The third connection type uses a precast column that has longitudinal bars extending from it. The bars are inserted into corrugated metal ducts in the adjacent member and the duct is filled with grout.

Some states with more ABC experience have refined connections based on their field experience. When necessary, they have relied on codes other than AASHTO requirements when designing and detailing some of the ABC connections.

ABC Connection Maintenance

The relatively short history of ABC makes it difficult to generalize about ABC connection maintenance issues or lack thereof. ABC connections are generally perceived to perform the same as conventional connections over time because they are mostly intended to be emulative. Nonetheless, some states inspect precast elements and joints annually rather than biennially, which is the normal frequency. They document field observations and use lessons learned to refine connection designs for future ABC projects.

Despite the confidence in emulative ABC details, agencies take many precautionary measures to minimize maintenance problems and improve durability. Joint details and construction procedures are evolving based on field experience. This trend is expected to continue.

Standardization of ABC Connection Details and Processes

Standardization of ABC applies to design and details, in addition to the process by which an agency selects the ABC alternative for a project.

With the expanding popularity of ABC, states are realizing that standard connection details need to be developed, although their philosophies differ. While some states believe that preapproved standard ABC connections should be provided, others believe that leaving flexibility in design and detailing could encourage widespread ABC use. More states appear to subscribe to the former view. Some of the standard details that are being developed do not meet AASHTO requirements. Some states do not allow couplers in plastic hinge regions of columns when the bridge is in SDC C or D because of AASHTO restrictions.

The process by which ABC is selected over conventional construction, although not specific to ABC connections, is important and relevant to this scan's objective. Decision-making tools are evolving at national and state levels and are becoming available. User costs are generally considered and used as a means of justifying ABC, although in many instances the initial cost is the primary consideration.

ABC Connection Research

Research focusing primarily on the seismic performance of ABC connections and members has been conducted. High-early-strength concrete is being studied, with a focus on developing standard mixes that can be used at closure pours to join prefabricated reinforced concrete deck elements.

ABC connections can be categorized as emulative or non-emulative connections. Emulative connection seismic research has focused on providing full continuity at the connection for the transfer of critical forces. Precast reinforced concrete columns embedded into footings, piles, or pier caps have been studied under cyclic loads with satisfactory results. Large-diameter bars anchored in corrugated metal ducts or standard couplers of various types for longitudinal bars also have been used. Various methods of converting multi-girder pier cap connections into integral pier caps also have been studied.

The versatility offered by precast members has encouraged research on non-emulative connection response under seismic loads. Post-tensioned segmental columns utilizing different details have been studied under slow cyclic and shake table loading. In some cases, sliding and rocking at joints are allowed to improve energy dissipation. In other studies, novel materials, like fiberreinforced concrete and built-in rubber pads, have been used in segmental columns to improve performance beyond that of conventional columns (i.e., by minimizing damage).

Various researchers have studied concrete-filled steel and fiber-reinforced polymer (FRP) tubes under slow cyclic and shake table loading. The column models are embedded into footings to provide full moment transfer. Results have demonstrated that the column-footing connections performed successfully.

Other means to improve seismic performance beyond emulative design has included the use of high-performance concrete, shape memory alloy reinforcement, and steel pipe pins in lieu of conventionally reinforced pins.

Innovative ABC Connections

ABC provides the opportunity to embrace innovation. In addition to research on using high-performance concrete, high-performance metallic materials, and the FRP materials previously described, various forms of innovative precast double-T girders are being considered for bridge superstructures. Folded-plate steel girders and concrete-filled FRP-tube arches are being implemented in selected bridges.

Post-tensioning has been used in bridge girders for decades. Many states are making use of post-tensioning in ABC through post-tensioned bridge decks and abutments. Transverse post-tensioning of girders in cap beam zones is considered one method of converting multi-girder pier cap connections into integral pier caps.

Base isolation, which has been used for conventional bridges, is being considered as a viable alternative to help reduce demand on ABC connections under seismic loads.

The FHWA Highways for LIFE (HfL) and Innovative Bridge Research and Deployment (IBRD) programs have served as mechanisms for field implementation of promising innovative concepts that have been developed based on research.

Monitoring ABC Connections and Prefabricated Bridge Elements and Systems

Some states conduct instrumentation and long-term health monitoring of prefabricated bridge components and their connections on a selected basis only when innovative, unconventional elements are utilized in the bridge. The purpose of gathering data on novel bridges, bridge components, and bridge connections is to determine any unexpected behaviors and learn about their responses. The general view about monitoring is that it may not be necessary, particularly when ABC connections are emulative.

Some of the bridges that are moved using self-propelled modular transporters (SPMT) are monitored during the moves to ensure that no overstress occurs in bridge components.

Other Findings

Extensive communication among different stakeholders (e.g., designers, contractors, top management, fabricators, industry, and the public) appears to have been the key to the successful

planning and execution of past ABC projects. Involving contractors early in the design and planning process alleviated issues and encouraged contractor participation in ABC, both because of the reduced financial risk and the shared risk associated with using new methods.

In some cases, the remoteness of precast plants relative to the job site might discourage the adoption of ABC. Although site casting of precast members may be viable, it does require added quality assurance and quality control.

More states are becoming aware of the importance of education and training for design and inspection of ABC projects. ABC design tools are also critical; many states are developing them to become an integral part of their bridge design manuals. Many lessons are being learned about the best practices of ABC. Despite the challenges associated with ABC, there is a great deal of enthusiasm and desire to use ABC. FHWA's HfL and IBRD programs are valuable vehicles for applying and showcasing ABC projects.

Recommendations

The scan team makes the following recommendations based on the scan and team discussions following the visits.

- **Continue research on MH load combination.** Studies should provide insight into any considerations that are unique to ABC connections. Once the research results are available and the potential methodologies for incorporating MH into LRFD are developed, an NCHRP project to transfer this research into AASHTO guidelines should be undertaken.
- **Establish a national center on ABC under MH loading.** The main goals of this center would be to:
 - ◆ Coordinate and integrate ABC research and development of design guidelines for MH loading consideration
 - ◆ Ensure that emerging ABC connections are simple and practical
 - ◆ Develop a library of standard ABC connections details
 - ◆ Provide assessments of different connections
 - ◆ Collect, compile, interpret, and develop a database of field performance of ABC connections
 - ◆ Develop performance characteristics of ABC components and connections for performance-based design methods
 - ◆ Coordinate with AASHTO to develop bridge design and construction specifications

-
- **Undertake extensive outreach to promote ABC to the bridge contracting community through The Associated General Contractors of America.** FHWA's Every Day Counts initiative has set a vision of which ABC is an important component. The outreach could be included in the mission of the center discussed in the previous recommendation.
 - **Expand the support of demonstration projects utilizing various ABC connections by FHWA's HfL program.** This will help showcase successful ABC design and implementation and promote ABC in areas where extreme loads are prevalent.
 - **Continue to do research on emulative design to facilitate its implementation in AASHTO specifications.** In turn, this will enable ABC to be fully implemented in regions of high seismicity and other extreme loads.
 - **Consider using innovative details, high-performance grouts, concrete, metals, and composite materials for future development,** even though emulative design is the most appropriate initial focus for codifying ABC connections. Innovative methods and materials have the potential to meet or exceed the target performance levels of emulative design.
 - **Investigate and inspect ABC projects in the field frequently, document performance data, and identify lessons learned until a sufficiently large database of field performance of ABC connections is compiled.** This effort could be undertaken in collaboration with the FHWA Long-Term Bridge Performance monitoring program to utilize the tools and processes that have become available in recent years.
 - **Update the AASHTO Guide Specifications for LRFD Seismic Bridge Design for implementation of ABC in SDCs B, C, and D.**
 - **Perform research and field monitoring and develop design and construction specifications for the use of high-early-strength concrete and grouts in closure pours for ABC connections.**
 - **Develop guidelines for shipping with respect to weights and sizes of prefabricated components.**

Introduction

Background

The National Cooperative Highway Research Program (NCHRP) Project No. 20-68A, U.S. Domestic Scan Program, is a broad initiative that considers innovative transportation-related practices used by some transportation agencies and that could be potentially adopted by other agencies to help advance their own state-of-the-practice. The purpose of the scan program is to collect and facilitate sharing of information and technology among the states and other transportation agencies and identify actionable items related to the dissemination of the findings and the implementation of best practices identified in the scan.

Each scan consists of a one- to two-week visit to several agencies and sites that are geographically dispersed, when feasible. The program includes annual cycles of topic selection, scans, and documentation.

One of the innovative practices a number of states use is accelerated bridge construction (ABC), which is intended to reduce the time and overall costs of bridge construction and its impact on the traveling public and improve work-zone safety, quality, and durability, among other factors¹. Working more efficiently is consistent with the aim of the Federal Highway Administration's (FHWA's) Every Day Counts initiative².

ABC practices often involve using prefabricated components that must be connected effectively to form a well-integrated bridge system that resists design loads. Connections of prefabricated elements are particularly critical under extreme event loading, such as high waves, tidal or storm surges, earthquakes, high winds, blasts, and other largely lateral forces acting on bridges. This scan focused on connections that are resistant to this type of loading.

Inevitably, there was some overlap between the scope of this scan and the scope of two previous scans. One scan was on prefabricated elements and systems in Japan and Europe³. The other scan was on accelerated construction techniques⁴, which addressed all aspects of transportation-related construction. Scan 11-02 focused on ABC connections and extreme loads. Any duplication with previous scans was minimal and only to the extent that was useful to the current scan's effort.

1 Accelerated Bridge Construction, FHWA, <http://www.fhwa.dot.gov/bridge/abc/>

2 Every Day Counts, FHWA, <http://www.fhwa.dot.gov/everydaycounts/>

3 Prefabricated Bridge Elements and Systems in Japan and Europe, http://international.fhwa.dot.gov/links/pub_details.cfm?id=495

4 Scan 07-02: Best Practices in Accelerated Construction Techniques, http://onlinepubs.trb.org/onlinepubs/nchrp/docs/NCHRP20-68A_07-02.pdf

Objectives, Purpose, and Scope

This scan's overall objective was to identify connection details that are used in the United States for ABC and perform well under natural or man-made extreme events, loading (e.g., those under waves and tidal or storm-surges), seismic events, blasts, and other large forces.

The types of ABC connections considered in the scan were broad both in terms of the category of bridge components that are connected and in terms of the materials and details used in the connection. This scan includes connections with conventional and innovative materials and details.

The team conducted the scan from March 25 to 31 and April 22 to 28, 2012, and included a variety of states and agencies with respect to the type of relevant extreme loads and ABC practices.

Although the scan's focus was on one type of bridge components (i.e., connections), the specific issue of performance under extreme loads necessitated gathering information on bridges in general regardless of ABC usage. It was important to determine if and how designers consider extreme loads for bridges and if and how designers combine extreme loads. By expanding the scan's scope to include extreme load consideration for conventionally constructed bridges, it was possible for the scan team to identify the underlying approach to extreme-load bridge design first, before focusing the scan's effort on ABC connections. Once the team had information on the different approaches states take in addressing extreme loads for non-ABC bridges, it became possible to pinpoint similarities and contrasts in the methods that are followed specifically for ABC bridges.

Another aspect of the scan that necessitated expansion of the scope was ABC bridge components themselves. The scan included aspects of precast component with respect to type, construction method, material, and details when the team believed that the information would help in discussing ABC connections.

Scan Team and Participants

Scan Team

The scan team consisted of eight members representing different stakeholders in ABC. The members were drawn from state departments of transportation (DOTs), FHWA, NCHRP, and academia. Table 1.1 lists the name and affiliation of each member. Jugesh Kapur chaired the scan; M. Saiid Saiidi served as the subject matter expert (SME). **Appendix A and Appendix B** provide contact information and biographical data for the scan team members, respectively.

Table 1.1 Scan Team Members

Name	Affiliation
Jugesh Kapur	Washington State DOT; American Association of State Highway and Transportation Officials (AASHTO) Chair
Alexander Bardow	Massachusetts Highway Department
Waseem Dekelbab	Transportation Research Board (TRB)
Michael Keever	California DOT (Caltrans)
M. Saiid Saiidi	University of Nevada, Reno (UNR); Subject Matter Expert
Joshua Sletten	Utah DOT
Daniel Tobias	Illinois DOT
W. Phillip Yen	Federal Highway Administration (FHWA)

Scan Participants

Table 1.2 and Table 1.3 list the agencies the scan team visited and the activities during the two weeks of scan (March 25 to 31 and April 22 to 28, 2012). The scan site visits comprised seven states and a number of institutions. In addition, five other states and institutions participated in scan meetings via web conference calls. Host agency key contact information is provided in **Appendix C**.

Table 1.2 Location and Activities of Week 1 Scan

Date (2012)	Location	Activities
March 25	Boston, MA	Meet at hotel Pre-scan team meeting for week 1
March 26	Boston, MA	Meet at FHWA Massachusetts Division Office 1 Two live web presentations by MCEER– State University of New York at Buffalo on FHWA project on multi-hazard bridge studies and seismic ABC research 2 Presentation by University of Massachusetts on ABC and innovative bridge health monitoring 3 Live web presentation by Texas DOT
March 27	Boston, MA	Meet at Massachusetts DOT (MassDOT) District 6 Seven presentations by MassDOT, PCI-New England, and CME Associates on the benefits, challenges, and successes of ABC; design and detailing; MA history of precast bridges and precast concrete sections; recent FHWA ABC manual; and constructability and construction of Fast 14 case studies
March 28	Boston, MA	Visit ABC bridge sites: Cedar St. over Rt. 9 Overpass in Wellesley River St. over railroad in Boston I-93 over Riverside Ave in Medford (part of the Fast 14 project)

Table 1.2 Location and Activities of Week 1 Scan (continued)

Date (2012)	Location	Activities
March 29	Tallahassee, FL	Meet at Florida DOT (FDOT) Four live web presentations, one by South Carolina DOT on standardized ABC details, two by the University of South Carolina on pile-cap ABC connections and on wireless corrosion assessment, and one by consultants on a bridge replacement project with precast bent caps
March 30	Tallahassee, FL	Meet at FDOT Seven presentations by FDOT on ABC philosophy, the Every Day Counts initiative training website, 118 th Ave. ABC case study, Edison Bridge inspection case study, and US-90 full-depth deck panel/precast substructure case study Visit the FDOT Testing Structure Research Center
March 31	Tallahassee, FL	Meet at Hotel Week 1 scan team wrap-up meeting

Table 1.3 Location and Activities of Week 2 Scan

Date	Location	Activities
April 22	Salt Lake City, UT	Meet at hotel Pre-scan team meeting for week 2
April 23	Salt Lake City, UT	Meet at Utah DOT Nine presentations by Utah DOT, the University of Utah, consultants, contractors, and fabricators on ABC practices, connection design, construction, maintenance, research, case studies, contracting, and fabrication
April 24	Seattle, WA	Visit Alaskan Way Viaduct and SR 520 bridge construction Visit University of Washington Structures Lab Two presentations by the University of Washington on ABC research projects
April 25	Seattle, WA	Meet at Alaskan Way Viaduct Design Office Seven presentations by Washington State DOT, consultants, and the University of Washington on the Alaskan Way Viaduct design-build project, ABC demonstration project, research, case studies, deployment, Washington State DOT ABC projects, and floating bridges
April 26	Carson City, NV	Meet at Nevada DOT Five presentations by Caltrans; Iowa State University; and the University of Nevada, Reno (UNR), on Caltrans ABC program, case studies, and Caltrans-funded ABC research
April 27	Carson City, NV	Visit UNR Structures Lab Meet at Nevada DOT Presentation by Nevada DOT on its ABC experience Scan team wrap-up meeting
April 28	Carson City, NV	Meet at hotel Scan team final meeting

Scan Approach and Planning

The following primary tasks were conducted to accomplish the scan's objectives:

- Develop preliminary amplifying questions
- Conduct desk scan
- Hold an organizational meeting of the scan team
- Conduct the scan visits
- Prepare a summary scan report and presentation
- Prepare the final scan report

Develop Preliminary Amplifying Questions

The purpose of amplifying questions, which were related to ABC connections under extreme events, was to provide a framework and focus for the most relevant issues and information that would maximize the return from the scan effort. The scan team members who were affiliated with different DOTs each provided an independent list of questions. The team members were also asked to identify states and individuals who were likely to provide potentially valuable information on different aspects of the multi-hazard (MH) loading effects on ABC connections. The SME processed, grouped, and compiled the amplifying questions and submitted them to different state DOTs as a questionnaire (see Appendix D).

The questions were grouped into six categories, each with four to 12 questions (40 total). The questions focused on ABC connections and MH loading combinations; however, closely related topics that provided a wider perspective on ABC were also included. The categories were:

- General issues on design for MH loading
- ABC design for MH loading
- Decision and design tools for ABC use
- Past ABC application
- Partnership with industry and research institutions
- ABC inspection and maintenance

Conduct Desk Scan

Literature Research and E-Mail Exchanges

A desk scan was conducted that included a brief summary review of the most relevant reports, papers, web materials, e-mail exchanges with researchers specifically involved in ABC connections under extreme events or MH loading studies, and a survey of nine state DOTs.

The objective of the desk scan was to collect and organize information to supplement and sharpen the scan focus and activities to maximize the return on the time and funding invested in the scan. A report summarizing the desk scan process and results was prepared and refined in accordance with the scan team members' comments. The highlights of the report are discussed in this document.

Review of published materials and web documents and e-mail exchanges with researchers indicated that, through FHWA funding, studies on combinations of MH loading on bridges are in progress. The studies are focused on bridges in general and are not specific to ABC bridge types or connections^{5,6}. Nonetheless, the scan team believes that the results from these studies could be of significant use for ABC connections as well.

Another important finding was the final report for NCHRP Report 698, Project 12-88, on ABC connections under seismic loading, which presents an excellent synthesis of the recent practice and research in this area⁷. Performance of ABC elements and connections under seismic loading was also the subject of NCHRP Report 681, Project 12-74, which studied different column precast bent cap connections in detail⁸. Although the scope of these reports is limited to seismic loading, the findings provide insight on ABC connections that potentially could be resilient under some of the other extreme loads that pose similar demand in terms of ductility and capacity.

5 Lee GC, M Tong, and T Dong, "On Design of Highway Bridges against Unintentional Hazards and Hazards and Malicious Attacks," Proc. US-Japan Workshop on Bridge Engineering, Washington, DC, October 4-6, 2004

6 Lee GC and Z Liang, "Multi-Hazard Resilient Bridges: Facts and Challenges," Proc. 7th CUEE and 5th ICEE, Tokyo, Japan, March 3-5, 2010

7 Marsh M Lee, M Wernli, BE Garrett, JF Stanton, MO Eberhard, and MD Weinert, "Application of Accelerated Bridge Construction Connections in Moderate-to-High Seismic Regions," NCHRP Report 698 (Project 12-88), TRB, Washington, DC, 2011, http://onlinepubs.trb.org/onlinepubs/nchrp/nchrp_rpt_698.pdf

8 Restrepo JI, EE Matsumoto, MJ Tobolski, "Development of a Precast Bent Cap System for Seismic Regions," NCHRP Report 681 (Project 12-74), TRB, Wash DC, 2011, http://onlinepubs.trb.org/onlinepubs/nchrp/nchrp_rpt_681.pdf

The desk scan revealed that several ongoing or recently completed research projects are focused on seismic performance of emulative and innovative ABC connections^{9,10,11,12,13,14,15,16,17,18,19,20}. The studies are being conducted at State University of New York at Buffalo (SUNY Buffalo); the University of California, San Diego; Iowa State University; the University of Nevada, Reno (UNR); the University of South Carolina; the University of Utah; and the University of Washington. The actual scan encompassed presentations and/or site visits that allowed information about most of these studies to be gathered; this information is presented in subsequent sections of this report. Limited studies of the effects of other extreme loads (e.g., hurricanes) were also found in the course of the desk scan²¹.

The FHWA, with the Every Day Counts initiative and the Highways for LIFE program²², recognizes the importance of ABC and has dedicated a website to ABC to provide an extensive resource,

-
- 9 Billington SL, JK Yoon, "Cyclic Response of Unbonded Post-tensioned Precast Columns with Ductile Fiber-Reinforced Concrete," *Journal of Bridge Engineering*, American Society of Civil Engineers, 9(4)2004, 353-363
 - 10 Haraldsson O, J Stanton, and M Eberhard, Laboratory Tests of Column-to-Footing Socket Connection (Draft Report). Washington State DOT, Olympia, 2010 (draft)
 - 11 Hewes JT and MJN Priestley, "Seismic design and performance of precast concrete segmental bridge columns," University of California at San Diego, Report No. SSRP-2001/25, 2002, http://www.dot.ca.gov/hq/esc/earthquake_engineering/Research_Reports/vendor/uc_san_diego/2001-25/SSRP%202001-25%20Final.pdf
 - 12 Hieber DG, JM Wacker, MO Eberhard, and JF Stanton, "Precast Concrete Pier Systems for Rapid Construction of Bridges in Seismic Regions" Report No. WA-RD 611.1, Washington State Transportation Center, 2005, <http://www.wsdot.wa.gov/research/reports/fullreports/611.1.pdf>
 - 13 Motaref S, M Saiidi, and D Sanders, "An Experimental Study of Precast Bridge Columns with Built-In Elastomers," *Transportation Research Record, Journal of the Transportation Research Board*, No. 2202, TRB, Washington, DC, 2010, 109-116
 - 14 Motaref S, M Saiidi, and D Sanders, "Segmental Bridge Columns with Damage-Free Plastic Hinges," Proceedings, Special International Workshop on Seismic Connection Details for Segmental Bridge Construction, Seattle, Washington, July 2009; MCEER Technical Report 09-0012, University of Buffalo, Buffalo, New York, December 2009, 75-82
 - 15 Ou Y, M Chiewanichakorn, A Aref, and G Lee, "Seismic Performance of Segmental Precast Unbonded Posttensioned Concrete Bridge Columns," *Journal of Structural Engineering*, ASCE, 133(11)2007, 1636-1647
 - 16 Saiidi, M, A Vosooghi, A Zaghi, S Motaref, and C Cruz, "Innovative Earthquake-Resistant Bridges- Repair, Connections, and Materials," Keynote Paper, Proceedings, International Conference IBSBI 2011, Innovations on Bridges and Soil-Bridge Interaction, Athens, Greece, October 2011, 107-123
 - 17 Sideris P, M Anagnostopoulou, A Aref, and A Filiatrault, "Investigation of the Seismic Response of Precast Segmental Bridges," 8th International Conference on Short & Medium Span Bridges 2010, August 3-6, 2010, Niagara Falls, Ontario, Canada
 - 18 Sideris P, M Anagnostopoulou, A Aref, and A Filiatrault, "Analytical and Experimental Investigation of Precast Bridge Systems," Proceedings of the Special International Workshop on Seismic Connection Details for Segmental Bridge Construction – Technical Report MCEER-09-0012, July 22-24, 2009, Seattle, Washington, USA
 - 19 Yen WP and GC Lee, Eds, Proceedings of the Special International Workshop on Seismic Connection Details for Segmental Bridge Construction Edited by MCEER-09-0012, December 2009, 204 pages, <http://mceer.buffalo.edu/publications/catalog/reports/Proceedings-of-the-Special-International-Workshop-on-Seismic-Connection-Details-for-Segmental-Bridge-Construction-MCEER-09-0012.html>
 - 20 Ziehl P, et al, "Testing of Connections between Prestressed Concrete Piles and Precast Concrete Bent Caps," Department of Civil and Environmental Engineering, University of South Carolina, Columbia, South Carolina, 2011, <http://www.clemson.edu/t3s/scdot/pdf/projects/SCDOT%20-Precast%20Caps-%207-11-2011.pdf>
 - 21 Padgett J E, A Spiller, and C Arnold, "Statistical Analysis of Coastal Bridge Vulnerability Using Empirical Evidence from Hurricane Katrina," *Structure and Infrastructure Engineering*, DOI:10.1080/15732470902855343, April 2009
 - 22 Highways for LIFE Program, FHWA, <http://www.fhwa.dot.gov/hfl/>

including success stories^{23,24,25}. Included are documents on ABC connections, many of which have the potential for resisting extreme loads.

The desk scan found that the ABC website at the Florida International University has provided another valuable resource by archiving the monthly ABC webinars, some of which have addressed ABC connection design for extreme loads^{26,27,28}.

Other websites identified in the course of the desk scan were those of various state DOTs (e.g., California, Florida, South Carolina, Texas, Utah, and Washington State^{29,30,31,32,33,34,35,36}) and different universities involved in ABC connection research^{37,38,39,40,41,42,43,44,45,46,47,48}.

- 23 Prefabricated Bridge Elements and Systems Cost Study: Accelerated Bridge Construction Success Stories, FHWA, <http://www.fhwa.dot.gov/bridge/prefab/successstories/091104/index.cfm>
- 24 <http://www.fhwa.dot.gov/everydaycounts/>
- 25 Accelerated Bridge Construction, FHWA, <http://www.fhwa.dot.gov/bridge/abc/>
- 26 Accelerated Bridge Construction, Florida International University, <http://www.abc.fiu.edu/>
- 27 Archive of Past Events, ABC, Florida International University, <http://www.abc.fiu.edu/archive-of-past-events/>
- 28 Presentation by Benjamin Tang, PE, Oregon DOT, and Toni Doolen, PhD, PI, OSU, ABC Florida International University, August 25, 2011, <http://www.abc.fiu.edu/event-on-08252011/>
- 29 Fixing Bridges, Doing Business Differently, MassDOT, <http://www.eot.state.ma.us/acceleratedbridges/>
- 30 Accelerated Bridge Construction, Caltrans, http://www.dot.ca.gov/hq/esc/Structure_Design/accel_bridge_construction/index.html
- 31 Accelerated Bridge Construction, Iowa DOT, <http://www.iowadot.gov/bridge/abc.htm>
- 32 <http://www.dot.state.fl.us/structures/Bulletins/2012/StructuresDesignBulletin12-07.pdf>
- 33 CTR Library, Center for Transportation Research, The University of Texas at Austin, <http://library.ctr.utexas.edu/index.html>
- 34 Accelerated Bridge Construction (ABC), Utah DOT, <http://www.udot.utah.gov/main/f?p=100:pg:0:::1:T,V:1991>
- 35 ABC Lessons Learned Reports, Utah DOT, <http://www.udot.utah.gov/main/f?p=100:pg:0:::1:T,V:3352>
- 36 Accelerated Bridge Construction Resources, WSDOT, <http://www.wsdot.wa.gov/eesc/bridge/ABC/>
- 37 Saiidi M, "Seismic Performance of Bridge Systems with Conventional and Innovative Design," UNR, <http://nees.unr.edu/4-spanbridges/>
- 38 Sustainable Highway Bridges with Novel Materials and Deconstructible Components, <http://wolfweb.unr.edu/homepage/saiidi/NSF-PFI/index.html>
- 39 Precast Bridge Columns with Energy Dissipating Joints, Caltrans, <http://wolfweb.unr.edu/homepage/saiidi/caltrans/precast.html>
- 40 Column Base Pipe Pins, Caltrans, <http://wolfweb.unr.edu/homepage/saiidi/caltrans/basepins.html>
- 41 Seismic Performance of Next Generation Bridge Components for Accelerated Bridge Construction, Caltrans, <http://wolfweb.unr.edu/homepage/saiidi/caltrans/nextgen.html>
- 42 Structural Engineering – Research, Civil and Environmental Engineering, UW, <http://www.ce.washington.edu/research/structural/research.html>
- 43 Experimental Seismic Response of Accelerated Bridge Construction System, MCEER, University at Buffalo, The State University of New York, http://mceer.buffalo.edu/research/Accelerated_Bridge_Construction/task2-3.asp
- 44 Post-tensioned Bridge Shows Excellent Performance Following Shake Table Testing at UB, MCEER, University at Buffalo, The State University of New York, <http://mceer.buffalo.edu/publications/bulletin/10/24-02/05ShakeTableTest.asp>
- 45 Seismic Performance of Precast Segmental Bridges, Structural Engineering and Earthquake Simulation Laboratory, <http://seesl.buffalo.edu/projects/accelbridge/default.asp>
- 46 Anchorage Requirements for Grouted Vertical-Duct Connectors in Precast Bent Cap Systems: A Summary, Project 0-4176: Development of Precast Bridge Construction Systems, Center for Transportation Research, the University of Texas at Austin, http://www.utexas.edu/research/ctr/pdf_reports/0_4176_S.pdf
- 47 Ziehl P, J Caicedo, D Rizos, T Mays, A Larosche, M ElBatanouny, and B Mustain, "Behavior of Pile to Bent Cap Connections Subjected to Seismic Forces," USC, <http://www.clemson.edu/t3s/scdot/pdf/projects/SPR%20672%20Final%20Report.pdf>
- 48 Ziehl P, J Caicedo, D Rizos, T Mays, A Larosche, M ElBatanouny, and B Mustain, "Testing of Connections Between Prestressed Concrete Piles and recast Concrete Bent Caps," USC, <http://www.clemson.edu/t3s/scdot/pdf/projects/SCDOT%20-Precast%20Caps-%207-11-2011.pdf>

Survey and Analysis

A major part the desk scan was a survey and analysis of information from nine select states with a known history of activities and interest in ABC in which one or more extreme loading event is considered. The participating states (i.e., California, Florida, Illinois, Iowa, Louisiana, Massachusetts, Texas, Utah, and Washington State) covered a large geographic area and have a variety of extreme load potentials. The survey results were analyzed and summarized in a desk scan report that the scan team discussed at its November 17, 2011, organizational meeting in Washington, DC. The following paragraphs present highlights of the survey's findings.

On the general issue of design for MH loading, most of the respondents identified vehicle collision, vessel collision, scour, earthquakes, and storm surges as the extreme loads they consider in bridge design. This is encouraging because the primary loading direction for these loads is lateral, which is generally in line with earthquake loading. Considering that the main thrust of recent and current research on ABC connections around the country is for seismic loading, lessons learned about seismic design of ABC connections could be useful when designing bridges for other, most relevant extreme loads. The AASHTO LRFD Bridge Design Specifications are used in their original or modified form to define limit states and to combine loading. The responses indicated that the AASHTO Guide Specifications for LRFD Seismic Bridge Design are being extensively used.

None of the respondent states give special consideration to ABC design under MH loading. ABC bridges and connections are treated the same as conventional construction; all field applications to date are emulative. The target performance levels (e.g., life safety and repairable) are also viewed to be the same as those of non-ABC bridges.

The state DOTs' current view of ABC connection design for MH loading cost versus conventional construction cost is that the ABC cost could be generally higher. However, several states indicated that the lack of data would not allow them to make a conclusive statement.

Decision and design tools for ABC are emerging. Nonetheless, the sensitivity of highway transportation agencies to the public's demand that construction-related traffic impacts be reduced and delivery speed increased has been heightened. ABC application is gaining substantial momentum despite a general lack of comprehensive and well-established decision tools. Most of the respondent states indicated that they have developed a process to determine if ABC is appropriate. Some states, such as Utah and Florida, factor in many parameters; their methods are available on the web. Some states are considering incorporating life-cycle cost analysis that includes traveler delay costs in their decision-making process. Emulative design is currently the preferred method for ABC connections; however, widely accepted standardized details and codified methods for emulative connections are yet to be developed.

Extensive past and current application of precast girders and, to some extent, precast deck slabs indeed constitute elements of ABC. There is ample experience with precast girders and their connections around the country. The most common ABC method the respondents use is the "rollin"

method, and many use self-propelled modular transporters (SPMTs). Prefabricated elements for other bridge components (e.g., columns, pier caps, abutments, and footings) have been used to a substantially lesser extent. Consequently, there is limited experience with the connections of these elements, especially under MH loading.

Another category of questions was on partnership with industry and research institutions. Most of the states find it necessary to collaborate with the industry and universities for ABC to succeed because ABC is a novel process that requires special consideration at various stages of design and construction. Even though emulative design is the preferred method to utilize ABC, the respondents are open to innovative materials for possible adoption in ABC.

In response to whether special inspection and maintenance procedures are developed for ABC bridges, none of the respondents reported the existence of any special procedure, although some mentioned a possible need for it for special cases. The respondents believe that post-event inspection procedures for conventional bridges could also be used for bridges in the ABC category.

Hold an Organizational Meeting of the Scan Team

After the desk scan was complete and the report submitted, the scan team met at the AASHTO headquarters in Washington, DC, on November 17, 2011. The team clarified the scan's goal and reviewed background information about the overall NCHRP domestic scan program. The team learned about the scan's various steps and the logistics related to travel and accommodation. Team member expectations were reviewed, and the final report's content was discussed. The importance of the scan recommendations and implementation plans was emphasized. The SME presented a summary of the desk scan's process, findings, and the highlights of the state DOT survey findings.

The next step was fine-tuning and finalizing the amplifying questions (see Appendix D). The initial amplifying questions were the basis of the desk scan survey's questions. Based on those initial responses, the team eliminated some questions and combined and enhanced others to make them clearer and more specific. Target respondents for different questions were grouped into two general categories, designers and contractors; some questions were applicable to both.

The revised amplifying questions were the basis of questions and discussions that the scan team would have with the agencies during the scan visits. The team asked the agencies being visited to respond to the amplifying questions prior to the scan team's visit, believing that this would help the agencies understand and provide the most relevant information to the scan team.

The desk scan enabled the scan team to create a preliminary ranked list of states and agencies to be visited and the topics for which potentially useful information on ABC connections could be obtained from each organization.

Although seven states were on the initial list, the team ultimately selected the following eight states and three institutions:

-
- California
 - Florida
 - Massachusetts
 - Nevada
 - South Carolina (participated through live web meetings)
 - Texas (participated through live web meetings)
 - Utah
 - State University of New York at Buffalo (SUNY Buffalo) (presented a live webinar)
 - University of Nevada, Reno (UNR)
 - University of Washington

Scan Findings and Observations

Primary Findings

ABC connection performance under MH loading is a multi-faceted subject encompassing information from many interrelated topics, most of which are still emerging. A mixture of highly intertwined technical and nontechnical considerations affects philosophical and practical approaches to ABC in general, and to ABC connections in particular. To better identify and communicate the scan results, the team categorized the discussions and findings into these topics:

- Extreme Load Consideration for Bridges and ABC Connections
- ABC Connection Details
- ABC Connection Maintenance
- Standardization of ABC Connection Details and Processes
- ABC Connection Research
- Innovative ABC Connections
- Monitoring ABC Connections and Prefabricated Bridge Elements and Systems
- Other Findings

Extreme Load Consideration for Bridges and ABC Connections

MH loading combinations are considered only to a limited extent even for conventional bridges because of a lack of guidelines and the general belief that the probability of simultaneously occurring, multiple extreme loads is low.

State Bridge Engineer Survey

To address the gap in knowledge and develop MH design guidelines, an FHWA-funded study is in progress at SUNY Buffalo, to establish a platform to include MH loading in LRFD for highway-bridges (MH-LRFD)⁴⁹. To help guide the study, state bridge engineers were surveyed⁵⁰ and invited to attend a workshop. The survey helped establish the current views and practices for MH design

49 George C. Lee, Mai Tong and W. Phillip Yen, "Design of Highway Bridges Against Extreme Hazard Events: Issues, Principles and Approaches," Technical Report MCEER-08-SP06, SUNY, Buffalo, June 2008, <http://mceer.buffalo.edu/publications/catalog/reports/Design-of-Highway-Bridges-Against-Extreme-Hazard-Events-Issues-Principles-and-Approaches-MCEER-08-SP06.html>

50 Lee GC, Z Liang, JJ Shen, and JS O'Connor, "Extreme Load Combinations: A Survey of State Bridge Engineers," Technical Report MCEER-11-0007, SUNY, Buffalo, October, 2011, <http://mceer.buffalo.edu/publications/catalog/reports/Extreme-Load-Combinations-A-Survey-of-State-Bridge-Engineers-MCEER-11-0007.html>

across different states and addressed both multiple simultaneous and cascading events.

Figure 2.1 presents a sample of the survey findings for the simultaneous action of scour, storm surge, and wind. Figure 2.2 shows the survey results for the cascading effects of different extreme loads.

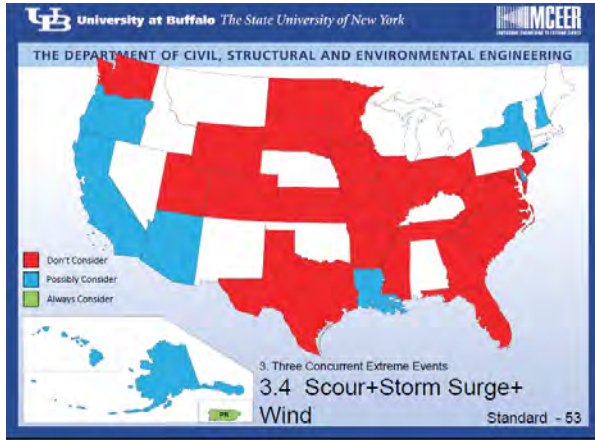

Figure 2.1 Survey results for consideration of three concurrent extreme events (i.e., scour, storm surge, and wind)⁵⁰

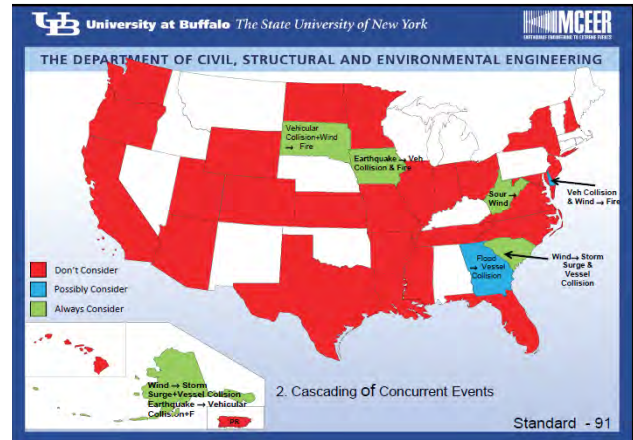

Figure 2.2 Survey results for consideration of cascading events⁵⁰

The survey’s results show considerable variation among the states with respect to how extreme load combinations are considered, depending on the geographical location and the extreme load type. The workshop helped identify the five load combinations of prime interest among state bridge engineers:

- Earthquake and live load
- Scour and earthquake
- Scour and vessel collision
- Earthquake and wind
- Vessel collision followed by fire

MH-LRFD

The focus of the current FWH study, which is on bridges in general and not specific to ABC or ABC connections, is on the first three load combinations. Due to a lack of extensive field and experimental data, the MH-LRFD platform is being developed primarily based on analytical studies. The current AASHTO LRFD framework is being used for eventual integration of limit states and load factors that will be developed in this study. MH-LRFD was chosen as the platform to integrate extreme hazard load effects with regular load effects using the probability-based approach, which will make it possible to evaluate the relative significance of different load effects on bridges.

Many challenges lie ahead because different extreme loads are handled differently in design, some being displacement-based and many being force-based. The initial intent is to develop load factors for different load combinations that would lead to the same reliability index ($\beta = 3.5$) that is currently used in the AASHTO LRFD specifications⁵¹. However, other reliability indexes are being considered to provide flexibility to designers.

MH-LRFD will be based on the probability of occurrence of different extreme loads and the design life of the bridge. Allowance will be made for connection failure under certain load combinations. Once completed, MH-LRFD could be implemented in Risks Due to Earthquake Damage to Roadway Systems (REDARS)⁵² to help manage transportation systems under MH loading conditions.

No special consideration of MH-LRFD is given to ABC at this stage because of the general belief that emulative ABC connections should perform as cast-in-place connections. However, with a flexible platform, it will be possible to assign different load factors to ABC connections than those used in cast-in-place construction.

ABC Connection Design Under MH Loading

The scan team could not identify information on ABC connection design under MH loading during the scan. Even under seismic loading, no specific AASHTO guidelines exist for ABC connection design despite the relative maturity of earthquake engineering of bridges.

In fact, restrictions on splicing longitudinal column reinforcement within the plastic hinge zone in seismic design category (SDC) C or D in the AASHTO Guide Specifications for LRFD Seismic Bridge Design severely limit the implementation of ABC in high seismic regions. This is consistent with the scan's findings that a correlation between the level of seismicity and the level of implementation of ABC practices exists.

The lack of widely accepted, well-developed, and proven ABC connection details has prevented extensive application of ABC in high seismic zones.

MH Load Combinations

Some MH load combinations exist in the current AASHTO LRFD specifications and are being used in design. Site-specific conditions have been considered in formulating MH loading on specific structures, such as floating bridges, in which wave action, wind load, anchor breakage, and vessel collision loading are considered in design.

51 AASHTO LRFD Bridge Design Specifications, Customary U.S. Units (6th Ed), 2012, http://www.knovel.com/web/portal/browse/display?_EXT_KNOVEL_DISPLAY_bookid=4852

52 Risks Due to Earthquake Damage to Roadway Systems (REDARS 2), MCEER, <http://mceer.buffalo.edu/research/redars/>

The performance objective may be different depending on the extreme load type. The combination of seismic loads and scour effect is considered as warranted, sometimes exceeding the levels specified in AASHTO LRFD Bridge Design Specifications. Field experience with the performance of conventional bridges during strong earthquakes has emphasized the importance of providing continuity, thus highlighting the critical nature of ABC connections under extreme loads.

Conclusions

Emerging technologies that utilize advanced materials in non-emulative ABC connections could allow for the use of performance-based design under MH loading with superior performance expectations. The MH-LRFD platform should allow for improved limit states when high-performance materials are used. Nonetheless, the scan has revealed that the development of MH-LRFD for bridges – both conventional and those utilizing ABC – is in its infancy. It appears that it will be several years before a codified MH-LRFD becomes available.

ABC Connection Details

Although ABC has generally been applied to a small fraction of the overall bridge population, numerous ABC connection types have been used by various states. Some states are adopting some of the connection details from the FHWA manual on ABC⁵³ for their ABC practice. Other states use these connections as a baseline and modify them to suit their needs. Texas, Massachusetts, Florida, Utah, and others are developing standard ABC connection details and making them available on their websites.

Figure 2.3 to Figure 2.9⁵⁴ show examples of various ABC connections for precast elements ranging from superstructure to substructure.

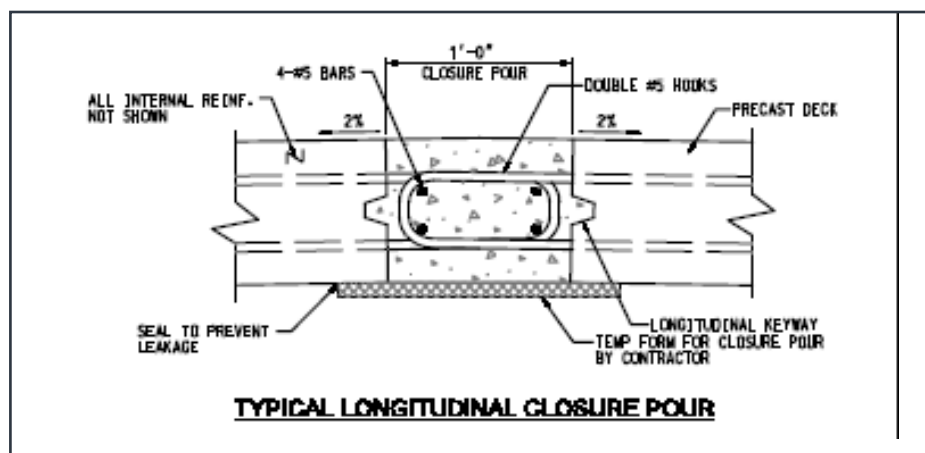

Figure 2.3 Full-depth precast concrete deck panel longitudinal connection

53 Accelerated Bridge Construction: Experience in Design, Fabrication and Erection of Prefabricated Bridge Elements and Systems, FHWA, November 2011, <http://www.fhwa.dot.gov/bridge/abc/docs/abcmanual.pdf>

54 Figures 2.3 through 2.9 are from Culmo M, “Connection Details for Prefabricated Bridge Elements and Systems,” FHWA-IF-09-010, Washington, DC, March 2009, <http://www.fhwa.dot.gov/bridge/prefab/if09010/report.pdf>

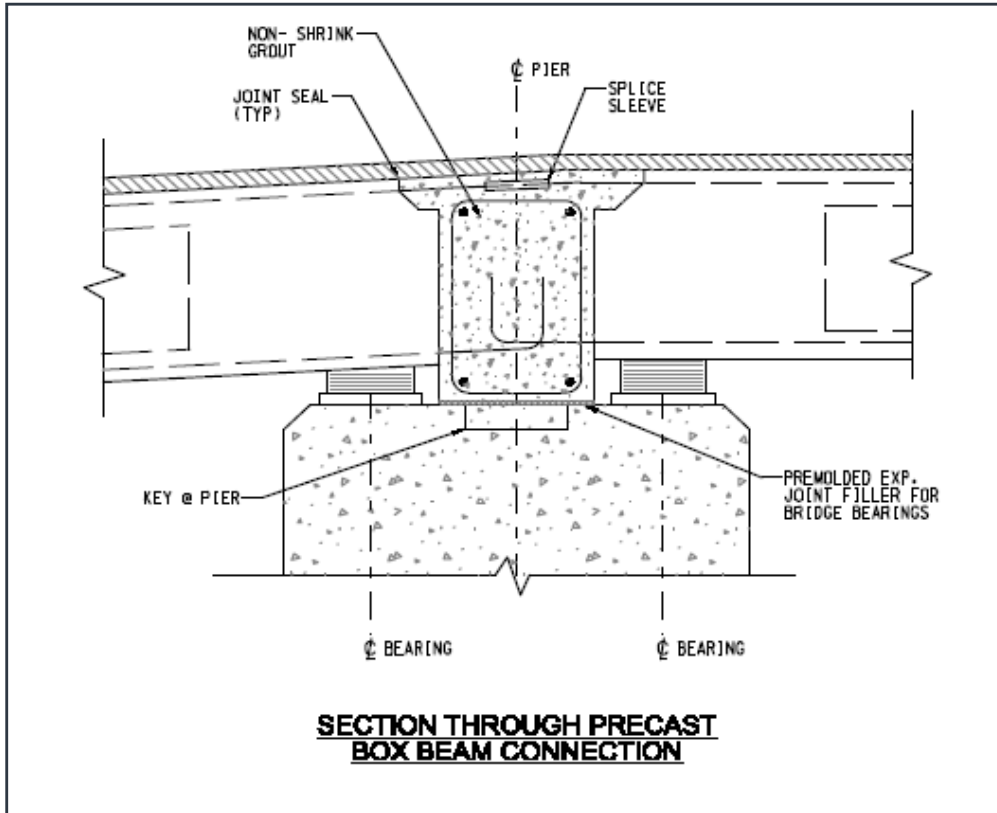

Figure 2.4 Precast box beam connection over pier cap

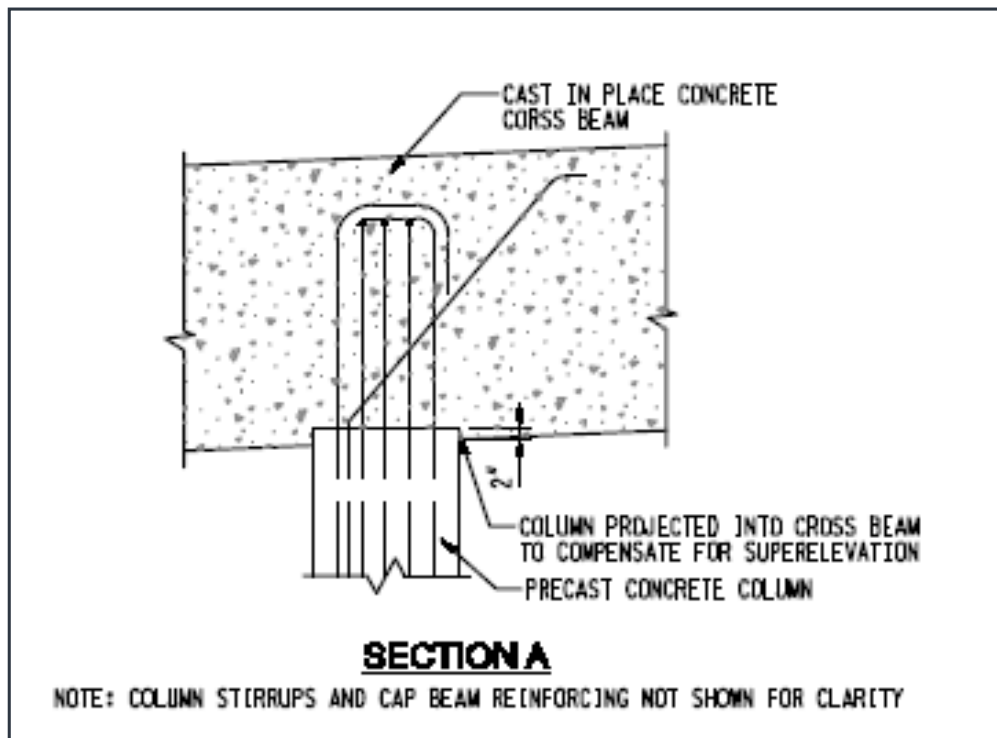

Figure 2.5 Precast column to cast-in-place cap beam connection

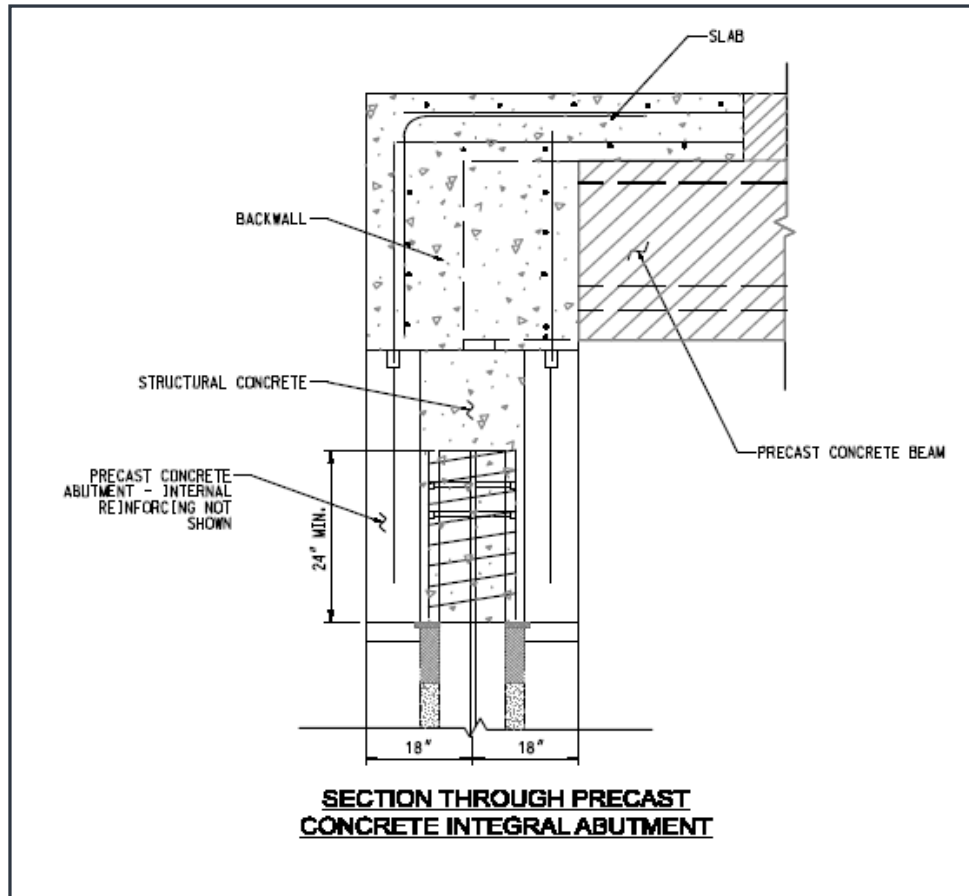

Figure 2.6 Precast girder to abutment connection

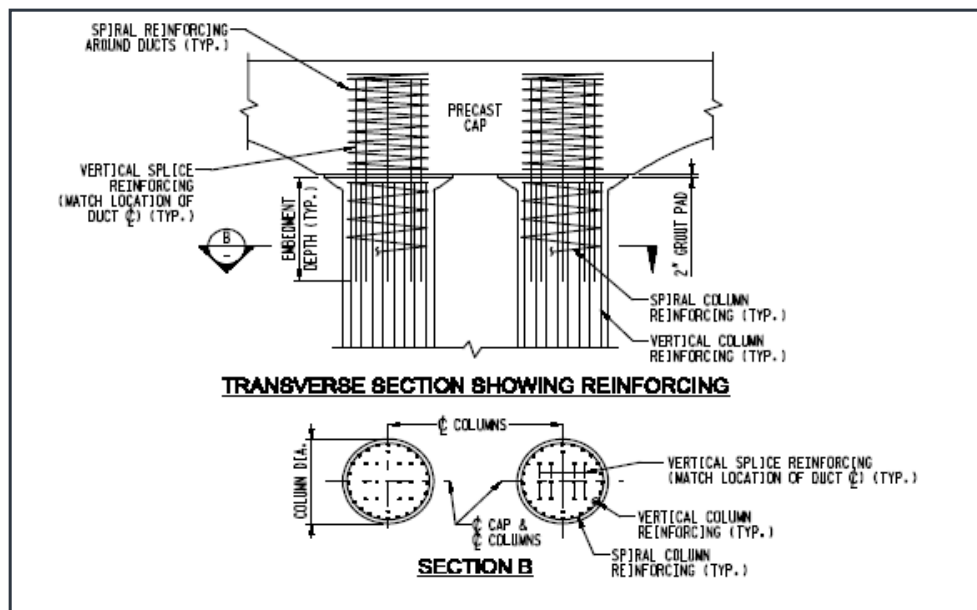

Figure 2.7 Precast column to precast pier cap connection

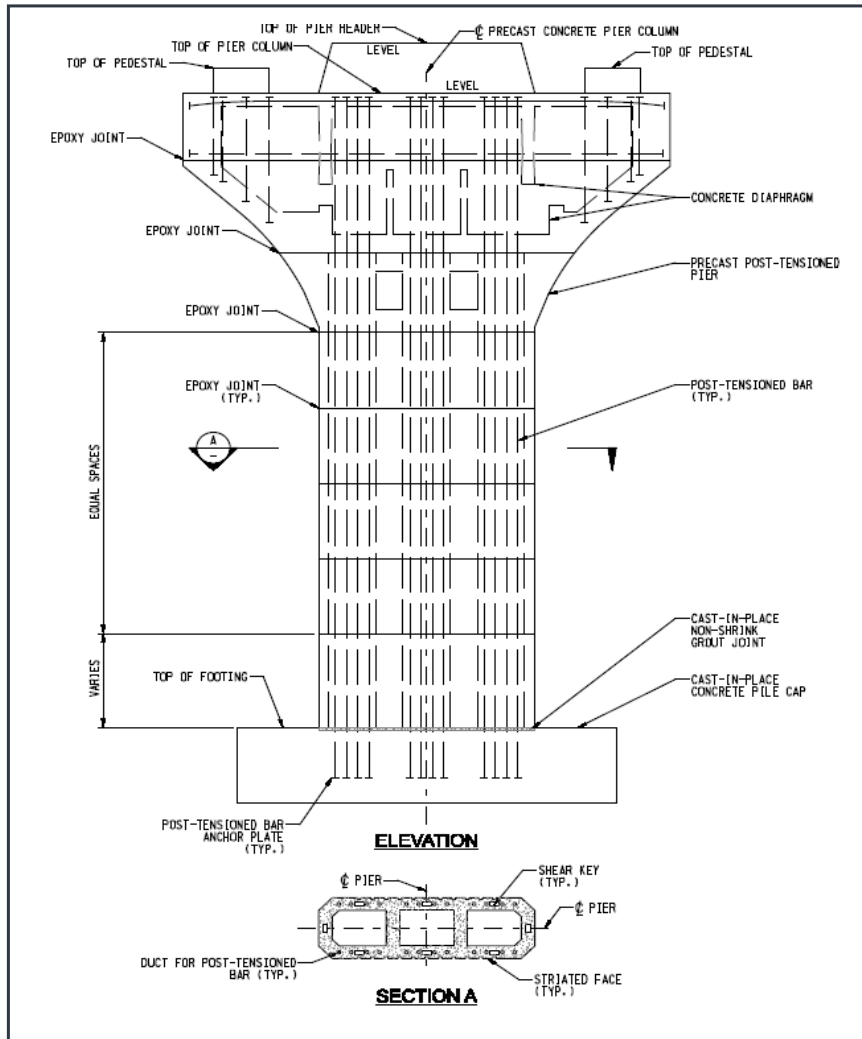

Figure 2.8 Segmental precast column connections

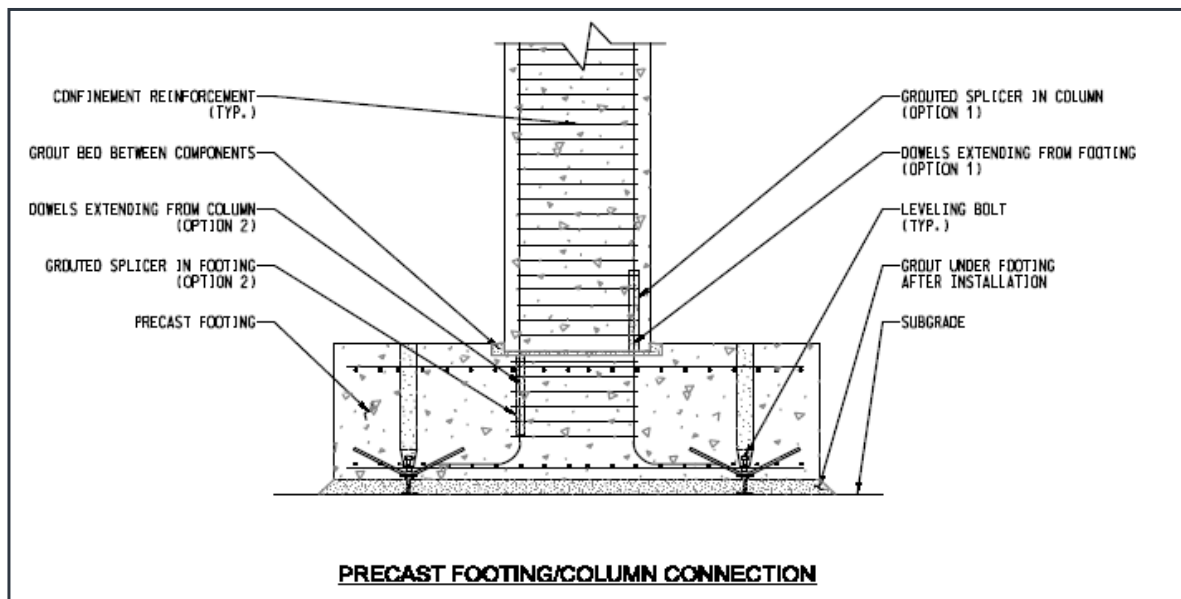

Figure 2.9 Precast footing to precast footing connection

In practice, ABC connections vary substantially with respect to detailing and performance objective. When the bridge superstructure is supported on bearings, some states do not provide any lateral restraint, thus allowing the bridge move freely in the horizontal direction under lateral loads, such as wind or earthquakes. In this case, bearing connections are designed for only vertical loading, but are sufficiently wide to prevent unseating. This philosophy is independent of whether the bridge is cast-in-place or precast.

Under storm surge, some states do not provide for tensile vertical force transfer at the support, thus allowing for uplift of the superstructure. Two reasons are behind this target performance:

- No established, proven connection details are available to prevent superstructure uplift.
- Preventing uplift transfers the upward forces to the substructure, which may or may not have sufficient uplift strength.

It is clear that preventing or permitting uplift has yet to be evaluated through research and discussion among stakeholders. Allowing uplift is in direct contrast with the performance objective of preventing bridge collapse (i.e., unseating) under seismic loads. The contrast between the performance objectives under storm surge and seismic loads presents yet another challenge in combining extreme loads in a codified form.

Full- or partial-depth precast superstructure deck panels and girders are commonly used with different types of connection details and concrete or grout mixes for closure pours. Figure 2.10 and Figure 2.11 present an example of full-depth precast deck panel connection to girders in a bridge on US 90 in Florida. An example of connection between adjacent deck panels at the FDOT Testing Structure Research Center is shown in Figure 2.12. Cast-in-place concrete is also commonly used as closure pour material between precast girders and girders and abutments (Figure 2.13). In some cases, precast deck panels are post-tensioned to improve durability; Figure 2.14 shows an example.

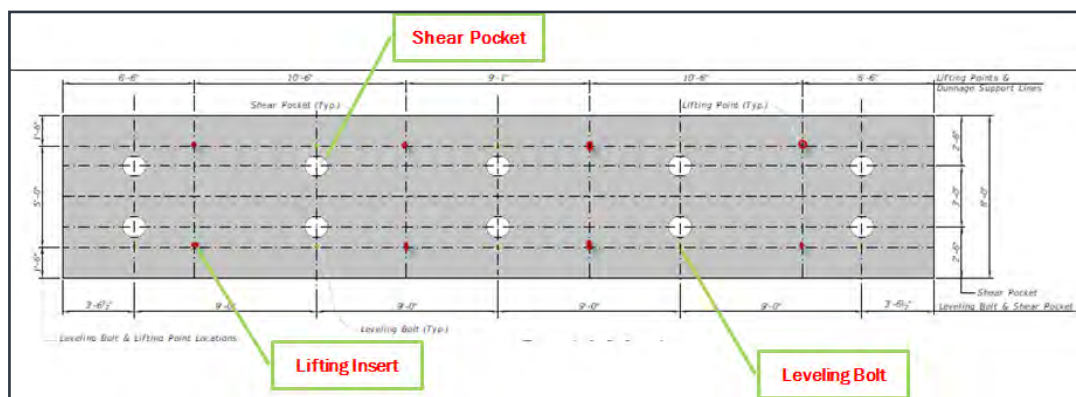

Figure 2.10 Full-depth precast deck panel with shear pockets for connection to girders

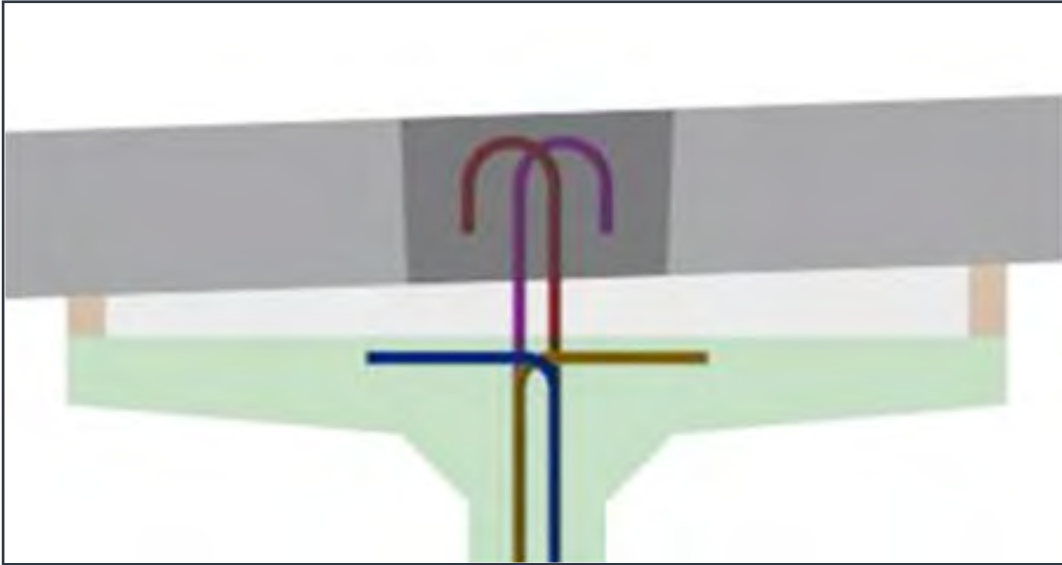

Figure 2.11 Shear pockets details for full-depth precast deck panel



Figure 2.12 Full-depth precast deck panel connection



Figure 2.13 Deck closure pour construction in Massachusetts Fast 14



Figure 2.14 Deck post-tensioning in Utah

Three types of ABC column were identified during the scan.

Embedded Column Ends

In one connection type, the column is embedded into the adjacent member (pile shaft, footing, or cap beam) a distance equal to a factor multiplied by column diameter or column side dimension. In the case of embedding in a footing or cap beam, the factor is approximately 1; for pile shaft connections it is approximately 1.5.

Figure 2.15 shows placement of a precast column into a cast in place (CIP) footing in a bridge in Washington State. The column had a square cross-section with a round core; however, the embedded segment was changed to an octagonal shape to improve anchorage in the footing.

The footing also may be a precast element. Figure 2.16 shows a precast-column-to-precast-footing connection developed as part of a study at UNR⁵⁵. Low-shrinkage grout was used to fill the space between the column and the footing.



Figure 2.15 Precast column to CIP footing connection in Washington State



Figure 2.16 Precast column to precast footing connection in a UNR study

⁵⁵ Motaref S, M Saiidi, and D Sanders, “Seismic Response of Precast Bridge Columns with Energy Dissipating Joints,” Center for Civil Engineering Earthquake Research, Department of Civil and Environmental Engineering, University of Nevada, Reno, Nevada, Report No. CCEER-11-01, May 2011, <http://wolfweb.unr.edu/homepage/saiidi/caltrans/Precast/PDFs/CCEER-11-01.pdf>

Figure 2.17 shows an example of a connection between a precast column and a precast shaft in Washington State. The collar around the column is CIP.

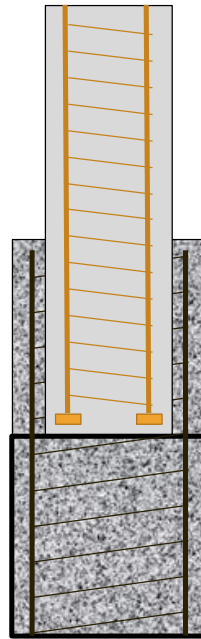

Figure 2.17 Precast column to precast shaft connection with CIP sleeve in Washington State

Figure 2.18 shows a square precast pile to CIP cap beam detail used in South Carolina. The embedment length is 1 to 1.3 times the pile section dimension.

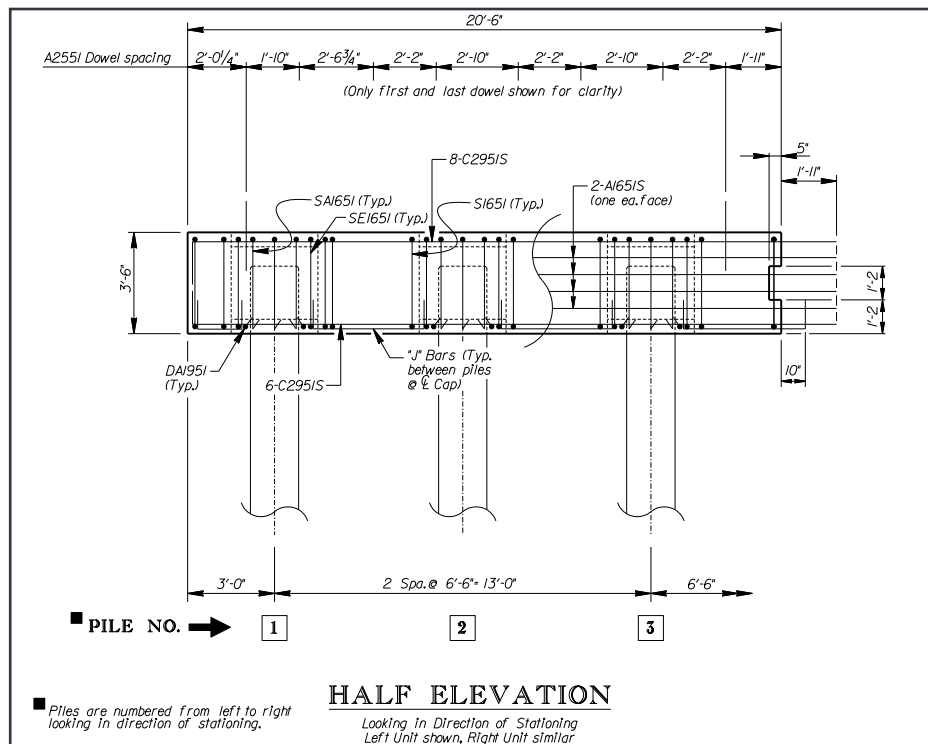

Figure 2.18 Precast pile to CIP cap beam connection in South Carolina

Grouted Couplers

A second connection type consists of grouted couplers that are typically embedded in a precast column or wall, connected to footing dowels, and grouted afterward. Figure 2.19 shows precast abutment walls connected with precast footings using grouted couplers in Massachusetts.

Figure 2.20 shows an example of grouted coupler embedded in a pier cap in a cap beam to column connection in Florida.



Figure 2.19 Precast abutment wall and footings with grouted coupler connections in Massachusetts

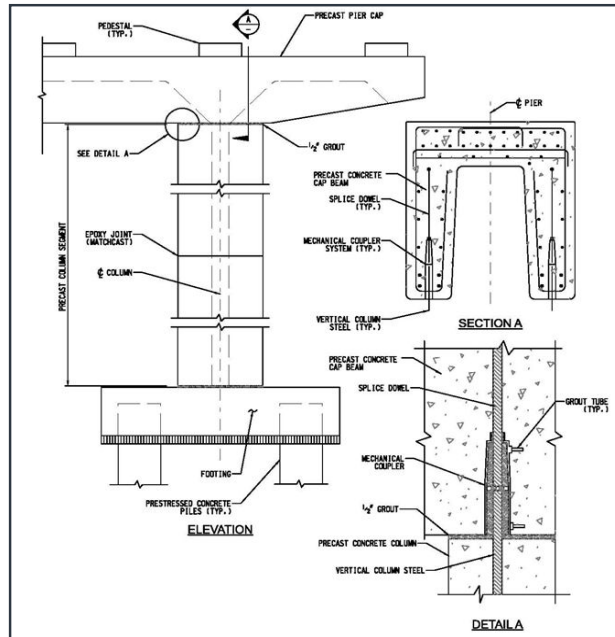

Figure 2.20 Precast column pier cap connection with grouted coupler in Florida

Grouted couplers have also been used to connect longitudinal bars in precast superstructure segments over piers (Figure 2.21).



Figure 2.21 Grouted coupler as continuity splice over pier in Massachusetts

Even though, according to AASHTO specifications, couplers are not allowed in plastic hinge areas of columns subjected to high seismic forces, they have been used in column-pile shaft connections in bridges in Utah, as shown in Figure 2.22. An exception to the AASHTO requirement was made on the basis that some of the other codes allow the use of mechanical splices in plastic hinges of reinforced concrete columns in high seismic zones. In the case shown in this figure, the coupler was embedded into the shaft, and the grout inlet and outlet ducts were installed for each bar.



Figure 2.22 Precast column connection to pile shaft with embedded grouted coupler in Utah

Grouted Ducts

In the third connection type, longitudinal bars extending from a precast column are inserted into corrugated metal ducts in the adjacent member and the duct is filled with grout. This connection is similar to grouted coupler connections except that the anchorage in the footing or cap beam is provided by the column's longitudinal bars directly, and not through a coupler that is connected to another bar that is anchored in the member.

Figure 2.23 shows the ducts placed in the precast cap beam, and Figure 2.24 shows the cap beam being lowered onto the column bars; the bridge is in Washington State. Figure 2.25 and Figure 2.26 show the type of detail used at UNR at the base of a large-scale column model with high-performance grout-filled ducts. Connections with corrugated pipes can also be used to connect precast abutment walls and piles (Figure 2.27).



Figure 2.23 Corrugated ducts in precast cap beam in Washington State



Figure 2.24 Placement of cap beam on column bars inserted in corrugated ducts in Washington State



Figure 2.25 UNR test model with corrugated ducts in footing

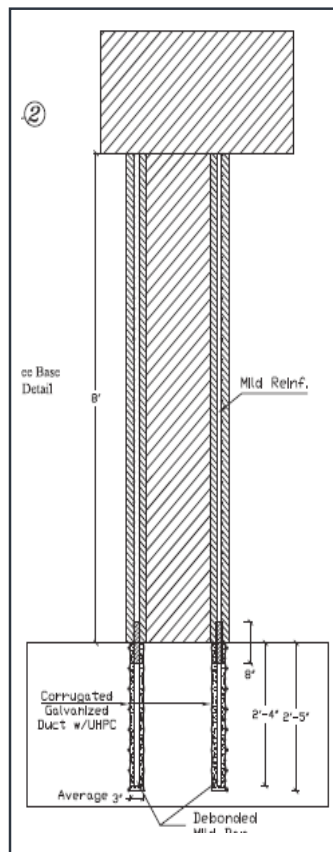

Figure 2.26
Elevation of UNR test model
with HPC grout in ducts

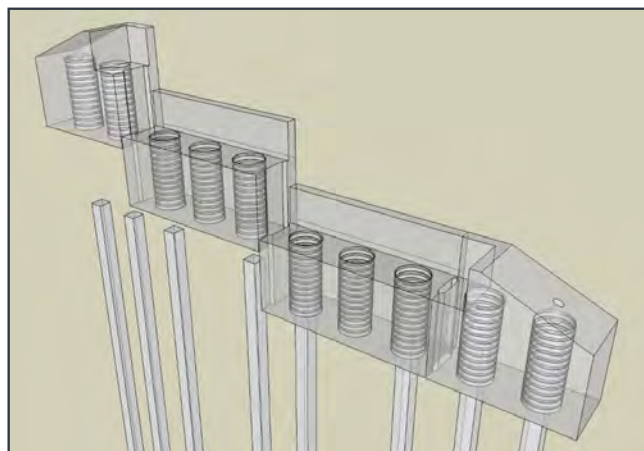

Figure 2.27 Precast abutment wall segments with embedded corrugated pipes⁵⁶

To construct integral abutments, high-strength bolts have been used to connect precast abutment back walls and end diaphragms of the superstructure. The detail shown in Figure 2.28 has been utilized in Utah.

56 Accelerated Bridge Construction: Experience in Design, Fabrication and Erection of Prefabricated Bridge Elements and Systems, FHWA, November 2011, p 174, <http://www.fhwa.dot.gov/bridge/abc/docs/abcmanual.pdf>

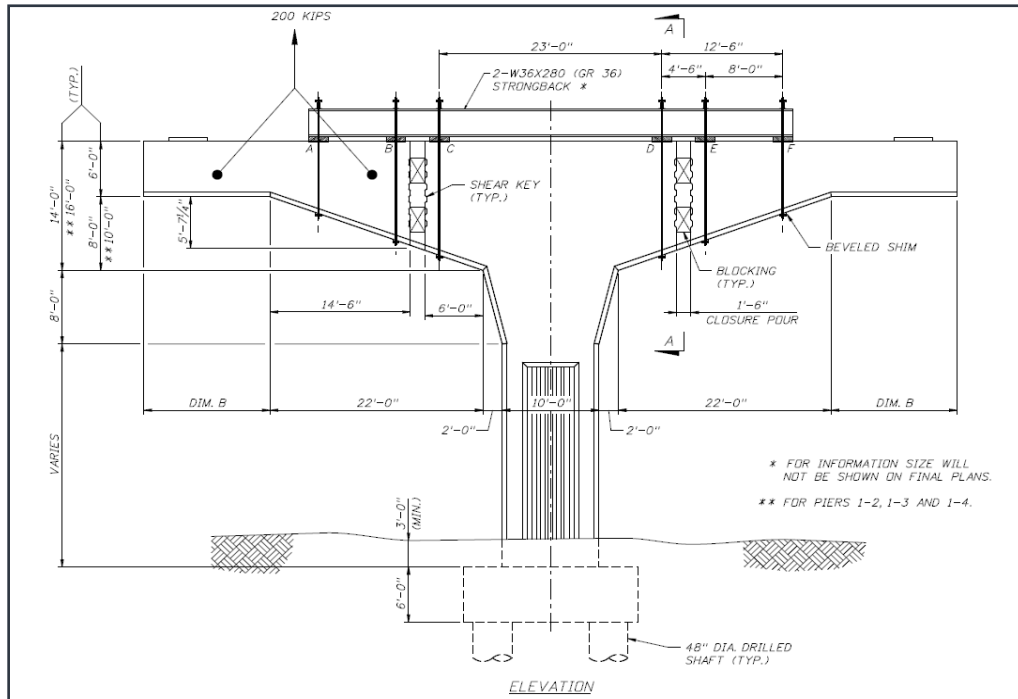

Figure 2.29 Segmental cap beam/pier system in Florida

ABC Connection Maintenance

Due to the relatively short history of ABC application, it is difficult to make a broad statement about maintenance issues or lack thereof in ABC connections. Generally, ABC connections are perceived to perform the same as conventional connections over time because they are mostly intended to be emulative. Field experience with a limited number of ABC projects that have been in service since the 1990s generally supports this view⁵⁸. When selecting ABC connections, bridge designers pay special attention to potential maintenance problems that might arise. The objective with respect to the durability of ABC connections is that they should be at least as good as conventional connections and preferably maintenance free.

Nonetheless, due to a lack of long history of ABC use, some states inspect precast elements and joints annually rather than biennially to monitor performance and ensure that any unexpected problem is addressed in a timely manner. Field observations are documented in some cases, and lessons learned are used to refine connection designs for subsequent ABC projects.

Despite the confidence in emulative ABC details, many precautionary measures are taken to minimize maintenance problems and improve durability. For example, “greased and sheathed” tendons are used in external post-tensioning, and plastic post-tensioning ducts rather than metallic are used to avoid corrosion. Some states use integral approach slabs to avoid problems at joints between approach slabs and the superstructure.

58 Accelerated Bridge Construction Applications in California: A Lessons Learned Report,” Caltrans, Version 1.1, August 2008, http://mceer.buffalo.edu/meetings/6nsc/review/ABC_LessonsLearned_v1_1.pdf

Special attention is paid to the grouting process, consolidation, and grout or concrete quality in closure pours. Some states indicate that excessive grout shrinkage cracking may require repair. Others report leakage at closure pours. As a result, grout work is done carefully, and the search for better performing grouts continues.

In some instances, decks are post-tensioned to alleviate joint maintenance problems. Joint details and construction procedures are evolving based on field experience. This trend is expected to continue.

ABC is considered to present an opportunity to embrace novel materials and details that deviate from emulative design. However, states are aware of the uncertainty in long-term performance of ABC projects with non-emulative design and the extra care and data that are needed during the design process. Over time, manuals for inspection and maintenance of both emulative and non-emulative connections need to be developed.

Standardization of ABC Connection Details and Processes

Standardization of ABC is viewed at both the microscopic and macroscopic levels, with the former concentrating on design and details and the latter focusing on the process by which an ABC alternative is selected for a project. The decision-making process to evaluate the viability of ABC covers factors that are broader than just ABC connections.

With the expanding popularity of ABC, states realize standard connection details need to be developed, although their views and philosophies differ. While some states believe that preapproved standard ABC connections would provide the tools for designers and contractors and would help expand ABC application, others believe that leaving flexibility in design and detailing could encourage widespread ABC use. More states appear to subscribe to the former view. PCI-Northeast⁵⁹ has developed manuals with standard details. Other states are developing manuals utilizing FHWA ABC details⁶⁰ in addition to their own documents for different precast element types and SPMT moves. FHWA ABC connections are frequently used as a baseline and are modified to suit the needs, conditions, availability, and construction practices of various states. Currently, Texas, Massachusetts, Florida, and Utah are at different stages of developing standard ABC connection details and making them available on their websites. Similar documents are expected to emerge from other states.

Utah has published manuals on different aspects of ABC, including a document on SPMT moves⁶¹ (Figure 2.30) and has made the manuals available on the Utah DOT website. Utah DOT also has developed a list of pre-approved grouted couplers to facilitate application of ABC.

59 PCI Northeast, A Chapter of the Precast/Prestressed Concrete Institute, <http://www.pcline.org/>

60 Culmo M, "Connection Details for Prefabricated Bridge Elements and Systems," FHWA-IF-09-010, Washington, DC, March 2009, <http://www.fhwa.dot.gov/bridge/prefab/if09010/report.pdf>

61 Accelerated Bridge Construction: SPMT Process Manual and Design Guide, Utah DOT, November 2009, <http://www.udot.utah.gov/main/uconowner.gf?n=11450820944206815>

Caltrans is developing standard pipe pin connections for use at column-cap beam joints. Figure 2.31 shows an example of a standard cap beam-column connection in Massachusetts.

Some of the standard details that are being developed do not necessarily meet AASHTO requirements. Some states do not allow couplers in plastic hinge regions of columns when the bridge is in SDC C or D because of the AASHTO restriction. As ABC research results become available and ABC practice evolves, issues of this nature should be resolved.

The process by which ABC is selected over conventional construction, although not specific to ABC connections, is important and relevant to the objective of this scan. Decision-making tools at the national and state levels are evolving and becoming available. User costs are generally considered and used as a means to justify ABC, although in many instances the initial cost is the primary consideration.

A pool-funded study was recently completed at Oregon State University to develop comprehensive decision-making tools to compare ABC with conventional construction and make recommendations⁶². Oregon, California, Iowa, Minnesota, Montana, Texas, Utah, and Washington State sponsored the study. Figure 2.32 shows the hierarchy and decision tree incorporated in this study. The key parameters used in the process and the ABC-AHP software⁶³ are schedule, direct and indirect costs, site constraints, and public service. Although the program has not yet been tried extensively, it is intended to provide ample flexibility to reflect local preferences and constraints and thus receive widespread use.

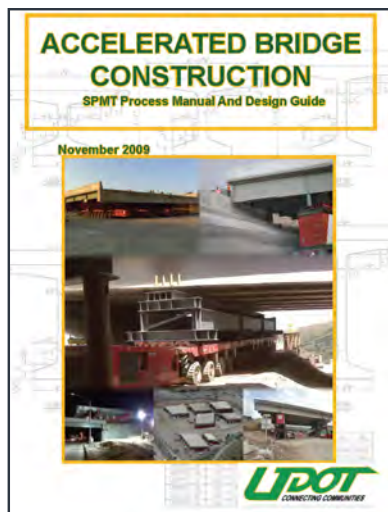

Figure 2.30
Utah manual and design guide
on SPMT moves

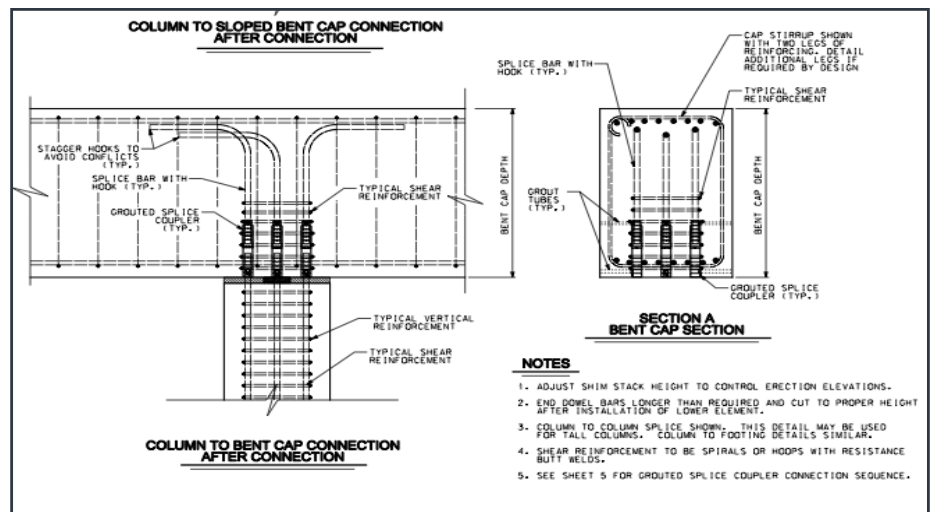

Figure 2.31
Cap beam-column connection used in Massachusetts

62 Doolen T, A Saeedi, and S Emami, “Accelerated Bridge Construction (ABC) Decision Making and Economic Modeling Tool,” FHWA-OR-TPF-12-06, Washington, DC, December 2011, http://www.oregon.gov/ODOT/TD/TP_RES/docs/Reports/2011/ABC.pdf

63 ABC AHP Decision Tool (manual), Project number TPF-5(221), Oregon State University, March 2012, http://www.fhwa.dot.gov/bridge/abc/dmtool/software_manual.pdf

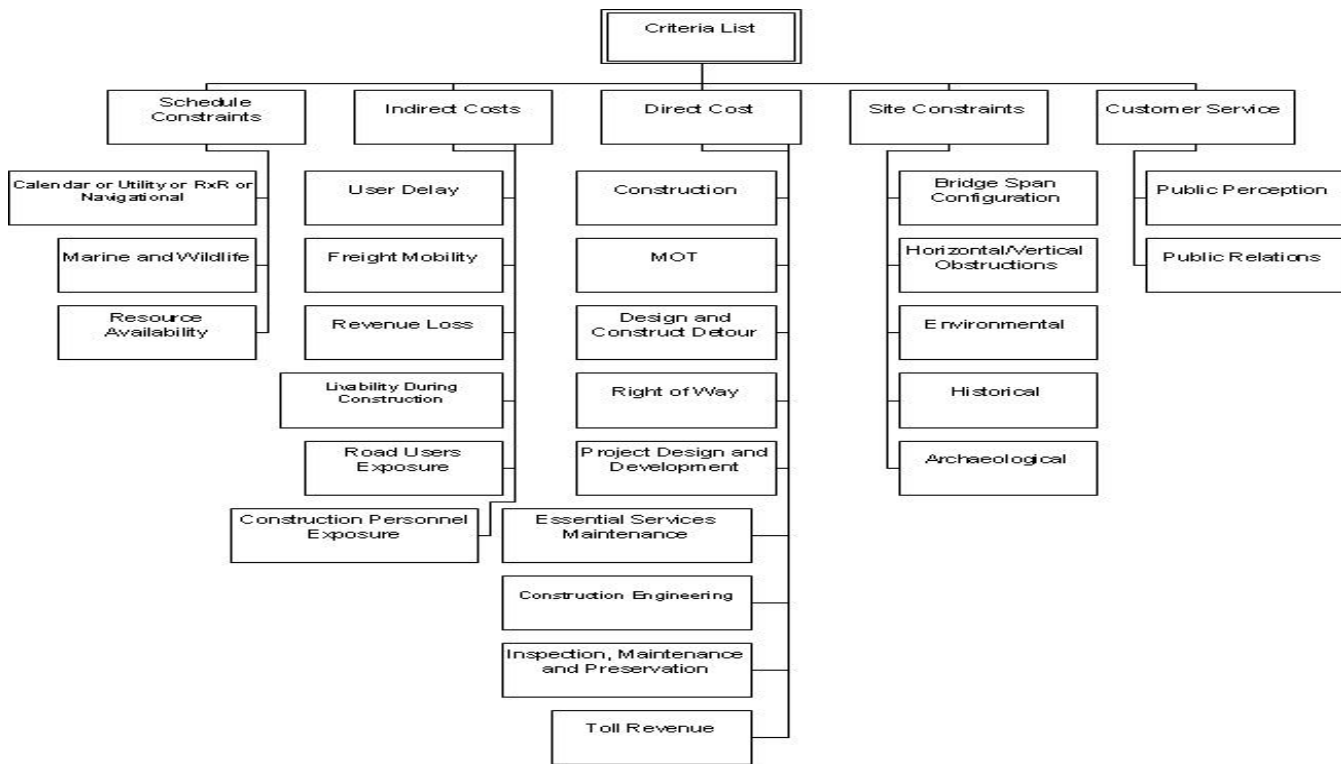

Figure 2.32 Decision criteria hierarchy⁶⁴

Several other states have developed decision-making processes with different levels of sophistication and posted them on their websites. While the higher initial cost of ABC may discourage some states from using ABC because of its budgetary impact on other projects, other states are beginning to view ABC as standard bridge construction. States with a longer history of ABC and a larger inventory of bridges constructed using ABC tend to be in the latter group as they have seen the cost of ABC decrease over time.

Because many contractors are new to ABC techniques and connections, the perceived financial risk is relatively high, which could translate to higher initial cost for ABC. Limited resources and the trade-off between doing fewer ABC projects versus a larger number of conventional construction projects could create a barrier to the widespread application of ABC.

Local preferences and upper-management receptiveness to ABC appear to influence the extent to which user costs are included in the decision-making process. Including user costs tends to justify ABC over conventional construction. Bridge engineers believe that DOT traffic divisions are best equipped to determine the impact of reduced construction time on the user. As contractors become more experienced with ABC, even the initial cost is expected to decrease. For example, shorter construction time could help reduce the project cost because of shorter equipment rental requirements, reduced labor costs, and other time-dependent costs.

64 Doolen T, A Saeedi, and S Emami, "Accelerated Bridge Construction (ABC) Decision Making and Economic Modeling Tool," FHWA-OR-TPF-12-06, Washington, DC, December 2011, http://www.oregon.gov/ODOT/TD/TP_RES/docs/Reports/2011/ABC.pdf

ABC Connection Research

Several institutions have conducted ABC connection research, focusing mostly on seismic performance of ABC connections and members. Limited studies on high-early-strength concrete hope to develop standard mixes that can be used at closure pours joining prefabricated reinforced concrete deck elements. Other studies have looked into detailing of the connections in full-depth precast deck slabs. Figure 2.33 shows a full-scale full-depth slab connection model tested at the FDOT Testing Structure Research Center in Tallahassee.



Figure 2.33 Full-depth deck slab connection model tested at the FDOT Testing Structure Research Center

Studies of ABC connections under seismic loads have been ongoing and could serve as a model to study the performance of ABC connections under other extreme loads. Research on ABC connections under seismic loading can be categorized as either emulative or non-emulative connections.

Emulative connection research has focused on providing full continuity at the connection in terms of transferring critical forces by using conventional materials, with the difference being that at least one of elements being connected is prefabricated. In some cases, steel reinforcement stresses are transferred through couplers of various types. These deviations from normal construction are designed so that they do not change the stress flow and performance of connections relative to that of conventional construction.

A study of conventional precast reinforced concrete columns embedded into precast footings, piles, or precast pier caps under cyclic loads found that they performed satisfactorily. As part of a FHWA/ Washington State DOT HfL project, a study at the University of Washington was conducted to determine the cyclic response of precast columns. Figure 2.34 and Figure 2.35 show the details of one of the test models. As intended in the emulative design, a plastic hinge was formed in the column and the footing was free of damage.

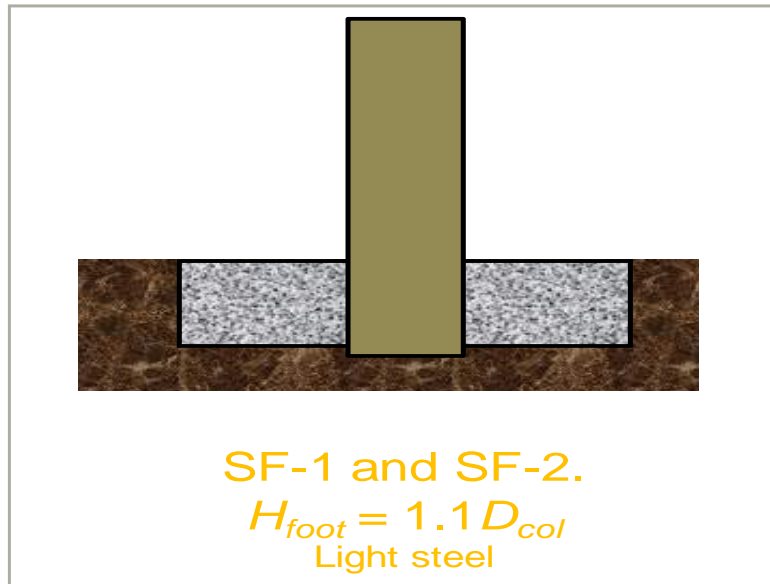

Figure 2.34 Model of a precast column model embedded in CIP footing at the University of Washington



Figure 2.35 Plastic hinge in precast column embedded in CIP footing

UNR has conducted studies in which both the columns and footings were prefabricated (Figure 2.16). Precast columns were placed in the footings and the space was filled with non-shrink grout. The connection performance in models tested on shake tables was satisfactory and comparable to that of CIP.

The University of South Carolina studied precast piles embedded in cap beam under slow cyclic loading (Figure 2.36). Some spalling of the concrete in the cap beam was observed; however, a plastic hinge was formed in the pile and the overall response was ductile.

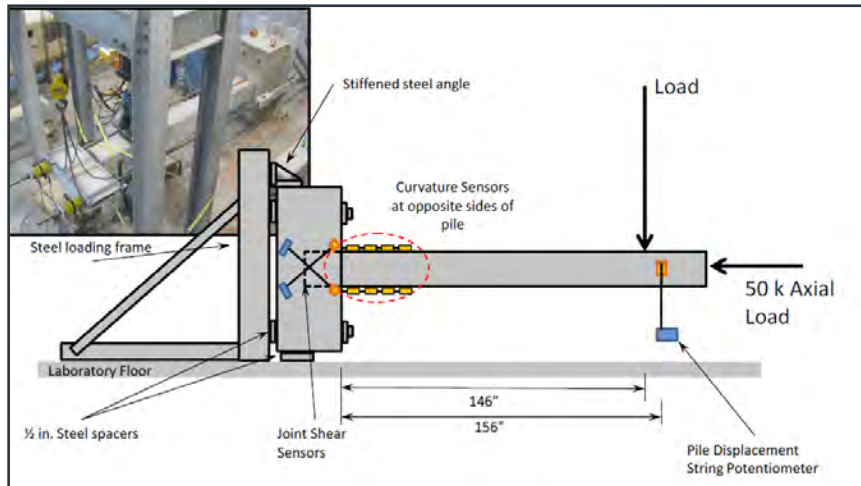

Figure 2.36 Pile cap beam connection model tested at the University of South Carolina

Other means of providing continuity has been through the use of large-diameter bars anchored in corrugated metal ducts. Florida has implemented the use of large-diameter bars to connect precast columns to cap beams. The University of Washington has studied the seismic performance of this type of connection. Figure 2.37 shows the concept. Figure 2.38 shows a test model representing column to cap beam connection in an upside-down setting to facilitate testing. The Washington State DOT HfL project has implemented this detail. Figure 2.25 and Figure 2.26 show a test model with column bars embedded in corrugated ducts in a footing that UNR is investigating. Ultra-high-performance grout is used at the connection.

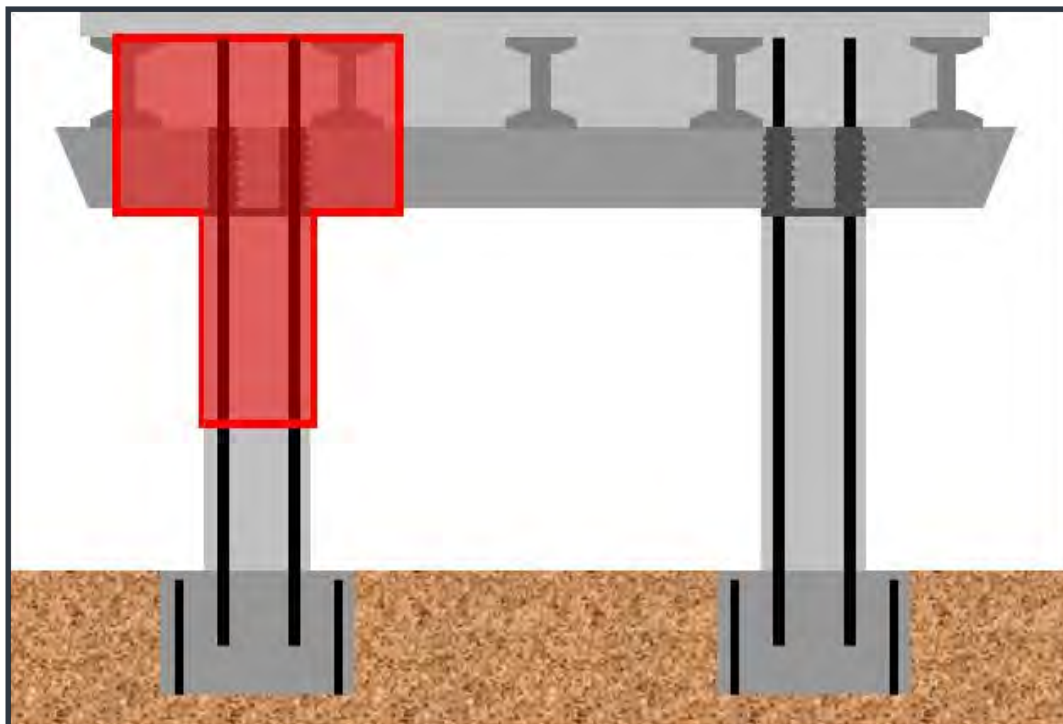

Figure 2.37 Column-cap beam connection with large diameter concept

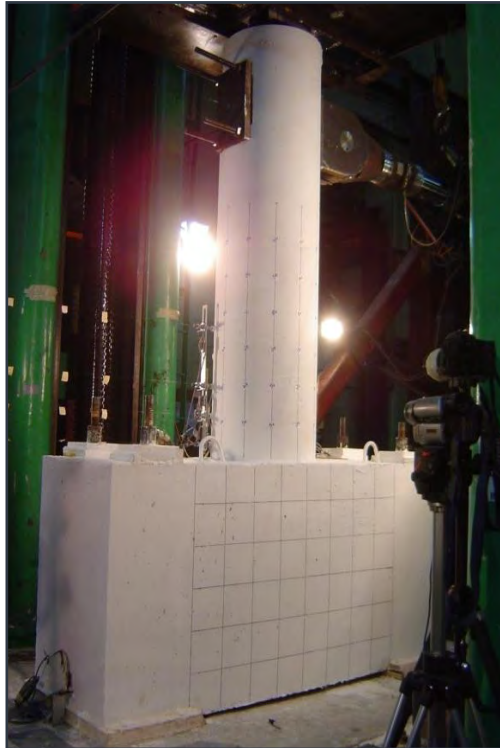

Figure 2.38 Column cap beam connection tested at the University of Washington

The seismic performance of different types of standard couplers of various types for longitudinal bars in column plastic hinges has been studied extensively in Japan for building-type connections; however, details specific to bridge columns are still under investigation.

Figure 2.39 shows a coupler system utilizing headed reinforcement that was tested at UNR under cyclic loads.



Figure 2.39 Precast column-footing connection model with headed bar couplers tested at UNR

In other column models, grouted couplers were used in the plastic hinge (Figure 2.40). The columns were hollow precast models filled with self-consolidating concrete after they were connected to the footing.

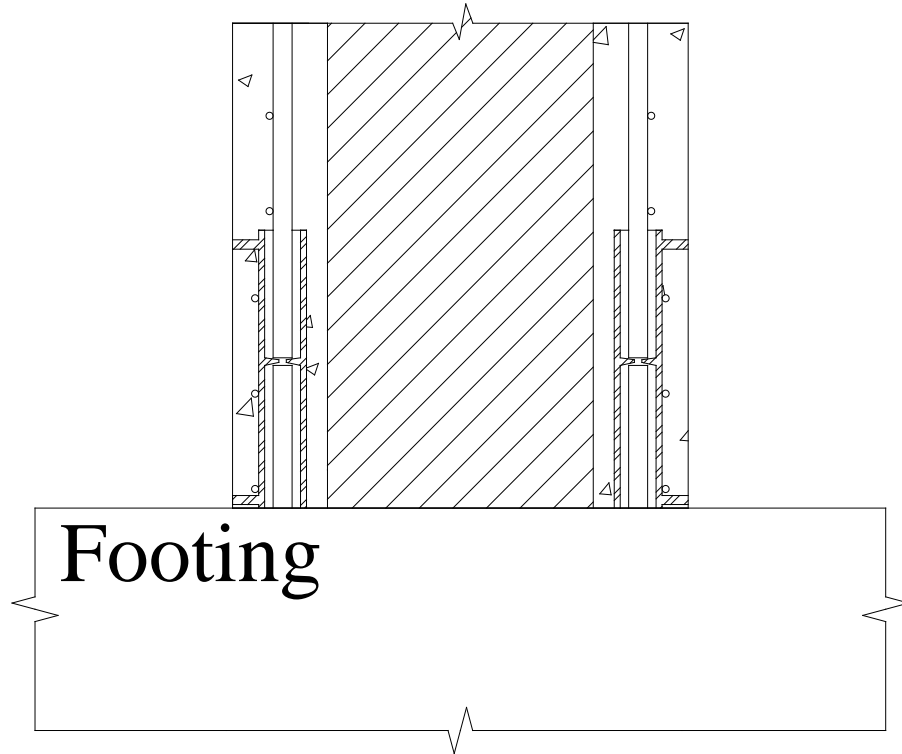

Figure 2.40 Precast column-footing connection model with grouted couplers tested at UNR

Figure 2.41 compares damage to the column models under 5% drift. The figure on the left shows a comparable CIP model. It is evident that the damage was comparable and the ABC connection performance was emulative. Under higher drifts, the model with headed reinforcement couplers exhibited higher ductility capacity than the one with grouted couplers. The UNR study continues on other variations of grouted coupler details to determine if the ductility capacity can be increased to the level of headed reinforcement couplers. Other experimental and analytical studies of the seismic performance of grouted coupler connections are in progress at the University of Utah.

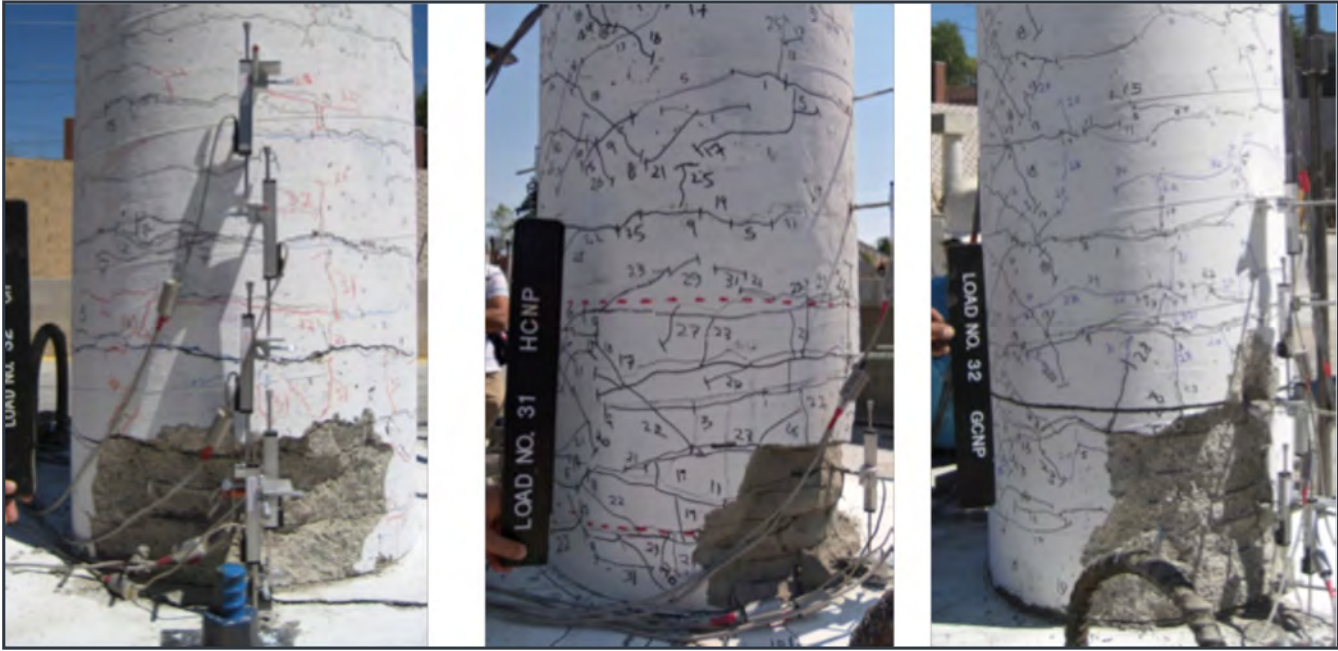

Figure 2.41 Damage at 5% drift ratio for models tested at UNR (left to right: CIP, headed bar couplers, and grouted couplers)

Various methods to convert multi-girder pier cap connections into integral pier caps by providing bottom reinforcement in the form of unstressed post-tensioning steel or high-strength bars though the joints are also being studied. Figure 2.42 shows the details of the former method used on the left side of the connection. Figure 2.43 presents the detail with high-strength bars through the diaphragm and the cap beam.

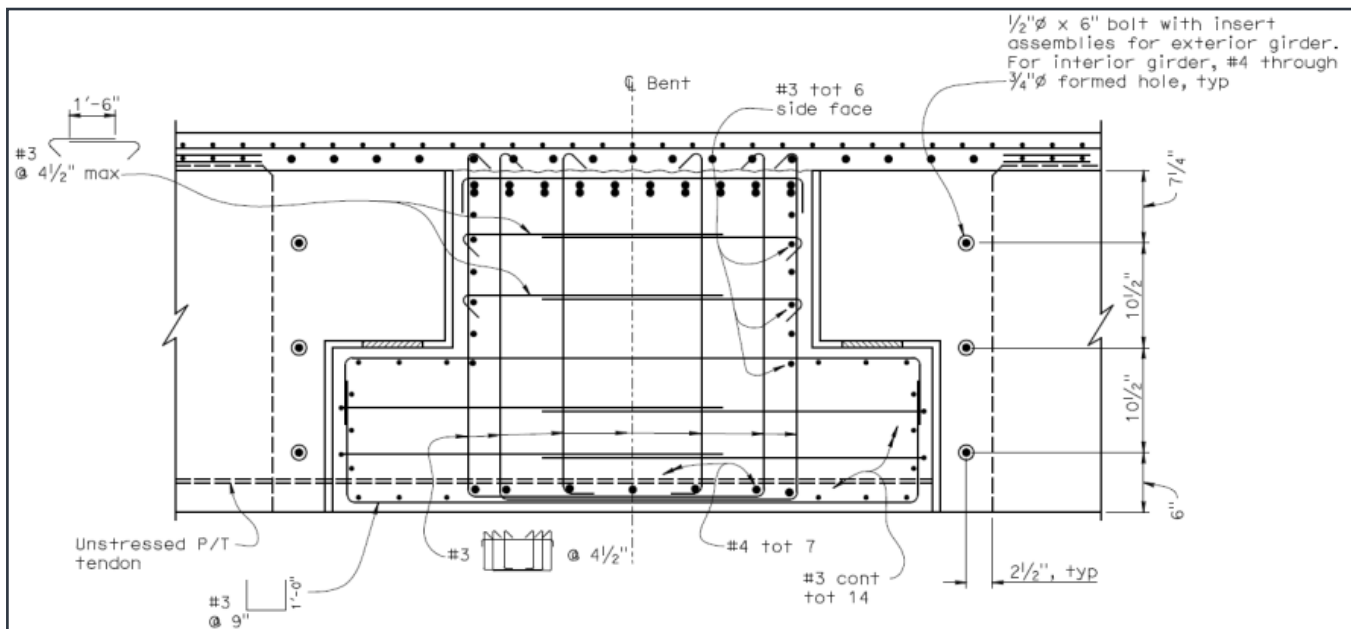

Figure 2.42 ISU superstructure/cap beam connection with unstressed post-tensioned tendon

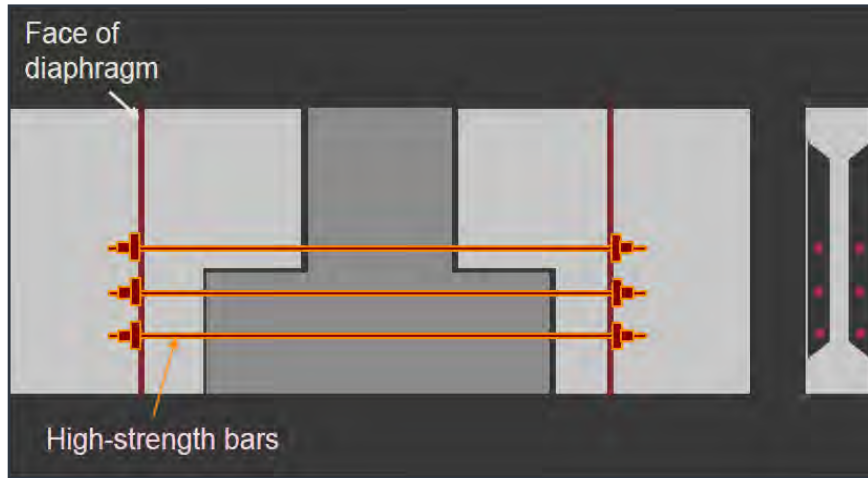

Figure 2.43 ISU superstructure/cap beam connection with high-strength bars

The versatility offered by precast members has encouraged research into non-emulative connection response under seismic loads. Post-tensioned segmental columns utilizing different details have been studied in various forms under slow cyclic and shake table loading. With post-tensioning, residual displacements are minimized and the performance of columns can be improved compared to conventional columns.

In some cases, sliding and rocking at joints are allowed to reduce seismic forces and improve energy dissipation. A study at SUNY Buffalo is focused on segmental column models, some with sliding at the segment joints (Figure 2.44). The sliding mechanism combined with post-tensioning provides for energy dissipation and restoring force that prevents permanent displacements.

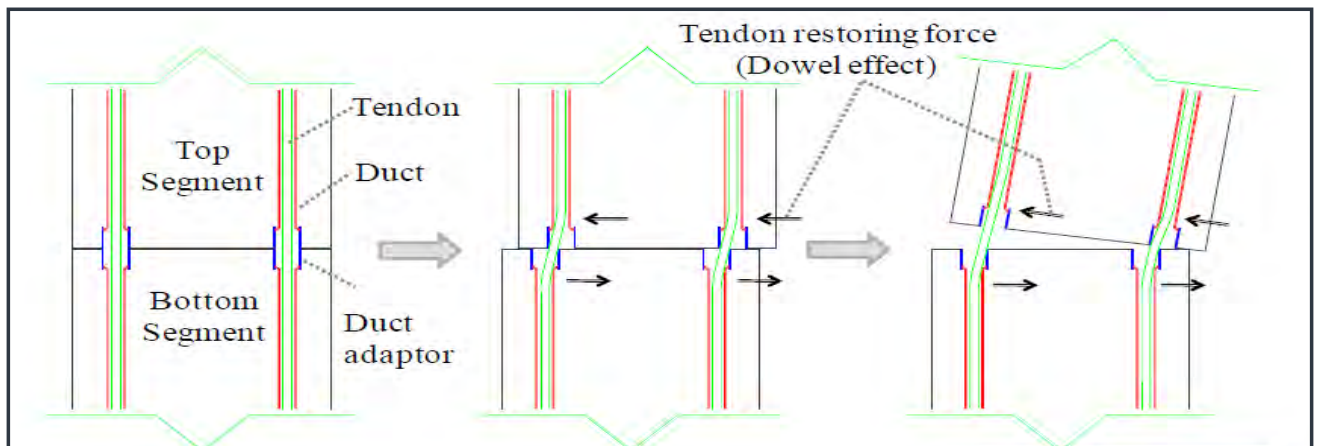

Figure 2.44 Segmental column connection with sliding joints tested at SUNY Buffalo

In a study at UNR, post-tensioned segmental cantilever columns with CIP base segments were subjected to shake table loading (Figure 2.45). The role of post-tensioning force was to connect the segments and re-center the columns as they underwent large lateral displacements. The earthquake energy was primarily dissipated through plastic deformation of the CIP base segments.

Other variations of post-tensioned segmental cantilever columns were studied with novel materials, such as fiber-reinforced concrete, built-in rubber pads, and FRP polymer wrapping. The objective of utilizing these novel materials was to reduce earthquake damage. The philosophy behind this approach is that by using novel materials, ABC connections and members can potentially perform to a higher standard than emulative design. Figure 2.46 presents the details of a shimmed rubber pad that was built into the column to deform in flexure with minimal shear deformation. Figure 2.47 shows the column model.

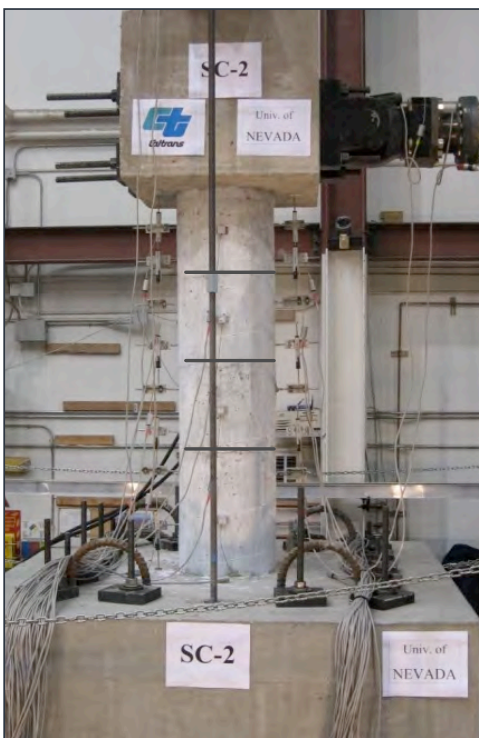

Figure 2.45
Segmental column model with CIP base segment on a shake table at UNR



Figure 2.46
Details of rubber pad incorporated into a segmental column model at UNR



Figure 2.47
Segmental column model with rubber pad on a shake table at UNR

Various researchers have studied concrete-filled steel and FRP tubes (Figure 2.48) under slow cyclic and shake table loading. The column models are embedded into footings to provide full moment transfer. The results have demonstrated successful performance of these column-footing connections. More research on the performance of these connections to pier caps is in progress.

Other means of improving the seismic performance beyond emulative design has included the use of:

- Concrete-filled steel tube columns
- High-performance concrete in the plastic hinge region of precast columns
- Shape memory alloy reinforcement
- Steel pipe pins in lieu of conventionally reinforced pins



Figure 2.48 Precast concrete-filled FRP tube column at UNR

Promising research results have been obtained for CIP construction utilizing these details. Cyclic response of prefabricated concrete-filled steel tube columns (Figure 2.49) at the University of Washington has shown that full moment can be developed at the column-footing interface. Steel pipe pins (Figure 2.50) were used at the top of two precast columns in a four-span bridge model tested on shake tables at UNR to connect with a precast cap beam (Figure 2.51). The study was successful in terms of both construction and seismic performance of the connections.



Figure 2.49
Concrete-filled steel tube column model tested at the University of Washington

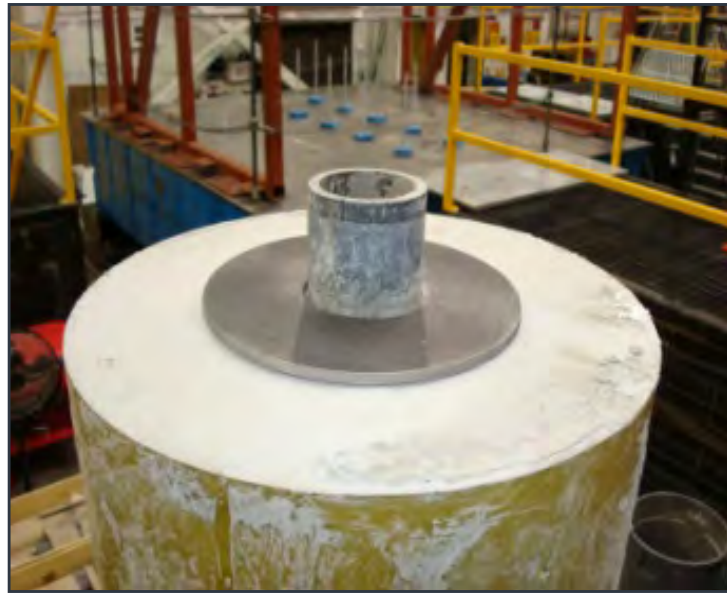

Figure 2.50
Steel pipe pin connection in a concrete-filled FRP tube column at UNR



Figure 2.51 *Lowering a precast cap beam onto steel pipe pin connections of a concrete-filled FRP tube pier at UNR*

Much progress has been made in understanding the seismic performance of ABC connections. However, research on ABC connections under other extreme loads is yet to be undertaken.

Innovative ABC Connections

ABC provides the opportunity to embrace innovation. In addition to research on using high-performance concrete, high-performance metallic materials, and the FRP materials described in the previous section, various forms of innovative precast bridge elements are being developed and implemented in the field. Connections of these members to each other or to other bridge components are designed mostly in emulative form; however, because these members are new, engineering judgment is also used.

Bridge-in-a-Backpack⁶⁵ is an example of innovative bridges utilizing carbon-fiber-reinforced polymer tube arches that are filled with concrete after the arches are installed (Figure 2.52).



Figure 2.52 Concrete-filled carbon-fiber-reinforced polymer tube arches implemented in a bridge in Massachusetts

65 Bridge-in-a-Backpack, Advanced Structures & Composites Center, University of Maine, <http://www2.umaine.edu/aewc/content/view/185/71/>

The Northeast Extreme Tee (NEXT) girder⁶⁶, recently developed in New England states, is another innovative and efficient girder in which the top flange forms the deck slab (Figure 2.53).



Figure 2.53 NEXT double-T girder used in Massachusetts

Although base isolation has been used for conventional bridges for some time, it is being considered as a viable alternative to help reduce demand on ABC connections under seismic loads. This could alleviate concerns about the reliability and ductility of ABC connections because of the reduced nonlinear deformation demands in the connections. The effectiveness of base isolation for other extreme loads, of course, is yet to be studied.

To help transfer promising innovative technologies that have been developed based on research into practice, FHWA's HfL and IBRD⁶⁷ programs have served as useful mechanisms with the potential to substantially spread the use of innovation in the field.

Monitoring ABC Connections and Prefabricated Bridge Elements and Systems

The general view about monitoring is that it may not be necessary when ABC connections are emulative. When grouted connections are used, the connection regions are inspected during and following construction, and necessary remedial measures are taken. This is due to the highly variable field performance of grouts and their sensitivity to variations in mixing and placement and to environmental effects. Because of a lack of data on past field performance of ABC connections, some states inspect them annually, rather than biennially, which is customary for conventional bridges.

Experience has shown that systematic monitoring of the bridge during SPMT moves is necessary to ensure that the superstructure is properly placed without overstressing any of the components. Such monitoring, of course, is short term and takes place only during the move.

66 Northeast Extreme Tee (NEXT) Beam, PCI Northeast,
http://www.pcine.org/index.cfm/resources/bridge/Northeast_Extreme_Tee_Beam

67 Innovative Bridge Research and Deployment Program, FHWA,
<https://www.fhwa.dot.gov/bridge/ibrd/program.cfm>

Instrumentation and long-term health monitoring of prefabricated bridge components and their connections are conducted on a selected basis only when innovative, unconventional elements are utilized in the bridge. Data on novel bridges is gathered to determine any unexpected behavior, learn about their behavior, develop accurate analytical and design tools, and identify any potential problems that require remedial measures.

The bridge shown in Figure 2.52 is one that is being monitored in Massachusetts. Strain gauges are installed on the carbon-fiber-reinforced polymer tubes and concrete. In addition, tiltmeters and displacement transducers are used to measure the movement of the arches. Another Massachusetts bridge, which utilizes steel folded plate girders (Figure 2.54), is also instrumented and being monitored using 75 strain gauges and several displacement transducers. The NEXT doubleT girders shown in Figure 2.53 are part of a third monitored bridge in Massachusetts. This bridge is skewed, and measuring live load distribution is of particular interest in the monitoring studies.



Figure 2.54 *Folded plate girder bridge in Massachusetts*

Other Findings

Extensive communication among different stakeholders (e.g., designers, contractors, top management, fabricators, industry, and the public) appears to have been the key to successful planning and execution of past ABC projects. Early involvement of contractors in the design and planning process alleviated issues and encouraged contractor participation in ABC by reducing financial risk and sharing the risk associated with new methods. Design-build projects present an opportunity for embracing innovation, including ABC, to save cost in the long run.

In some cases, the remoteness of precast plants relative to the job site might prevent the adoption of ABC. Creative solutions might be found by involving all stakeholders in early stages of ABC projects. For example, rather than plant-casting then paying for a high shipping cost of bridge components, the components could be cast on site. However, added quality assurance and quality control is necessary to ensure that site casting meets the standards set for plant casting.

Switching from conventional construction changes the role of contractors from constructors to installers of precast members. Installing ABC connections may require a higher level of skill than that normally required for construction. Because of this, some contractors might be resistant to the change both in their role and in their labor skills. Early contractor involvement could address this issue because of the lead time it provides to make adjustments.

More states are becoming aware of the importance of education and training for design and inspection of ABC projects. ABC design tools are also critical and are being developed by different states to become an integral part of their bridge design manuals.

Many lessons about best practices are being learned in ABC. For instance, converting circular columns to octagonal columns facilitates the casting of prefabricated columns on their sides. Difficulties in assembling multi-segment precast columns have led to the conclusion that segmental columns should be avoided unless necessary due to weight limits or other considerations. Transporting short, heavy segments could be challenging because of the need to spread the weight over several truck axles to avoid exceeding weight limits.

Despite the challenges associated with ABC, the state DOTs have a great deal of enthusiasm for and desire to use ABC. FHWA's HfL and IBRD programs are valuable vehicles for applying and showcasing ABC projects, thus increasing states' confidence in adopting ABC.

Recommendations

The following recommendations are made based on this scan and discussions during the scan team's meetings following the site visits

Continue Research on MH Load Combination and the Effects of Extreme Loads on ABC Connections

Research needs to continue on MH load combination effects on bridges and reliability-based methods to design for MH. The research and resulting design methods need to be inclusive of all extreme loads that are relevant both to the nation as a whole and to those specific to particular geographic regions. Design methods should provide sufficient flexibility to designers to choose the reliability indexes that they deem appropriate and relevant to their jurisdictions. The studies should provide insight into any considerations that are unique to ABC elements and connections for different types of extreme loads.

Given the scarcity of experimental and analytical research data on ABC connection performance under extreme loads, the proposed design methods will be inevitably tentative even when they reflect the state-of-the-art. The lack of data needs to be addressed through extensive research. For example, very little is known about the behavior of ABC connections under loading from ship collision, scour, blasts, and fire. Even under earthquake loading, the amount of research data on ABC connections is limited, and more extensive studies are needed. With additional research, future versions of MH loading design will be able to utilize data for more rational and realistic loading and structural behavior.

Once research results are obtained and potential methodologies to incorporate MH in LRFD are developed, even in preliminary forms, it is recommended that an NCHRP project be undertaken to transfer this research into AASHTO guidelines to provide tools for designers.

Establish a National Center on MH Design of ABC Bridges

A national center on ABC-type bridges and connections subjected to MH loading should be established. The main goals of this center should be to:

- Coordinate and integrate ABC research and development
- Develop design guidelines for MH loading consideration
- Ensure that emerging ABC connections meet performance requirements while being simple and practical

- Develop a library of standard ABC connection details to provide users a variety of choices
- Provide assessment of different connections and make recommendations about the application of different standard details under different extreme loads
- Collect, compile, interpret, and develop a database of field performance of ABC connections
- Serve as a central source for education of various stakeholders and dissemination of information about the history, design, maintenance, inspection, and other aspects of ABC components and connections that are resistant to MH loading
- Develop performance characteristics of ABC components and connections for performance-based design methods
- Coordinate with AASHTO to develop bridge design and construction specifications

The information on prefabricated bridge elements and publications on ABC that are posted on the FHWA website have been valuable in introducing and promoting ABC. The ABC center at the Florida International University has organized monthly webinars that have helped inform bridge designers about many case studies. The recommended MH-ABC center will be substantially more comprehensive with sufficient funding to thoroughly address all the key aspects of ABC.

Establish Ongoing Communication to The Associated General Contractors of America and other ABC Stakeholders

FHWA's Every Day Counts initiative has set a vision of which ABC is an important component. Extensive outreach to inform about and promote ABC to the bridge contracting community through The Associated General Contractors of America, operators of precast plants, fabricators of ABC connections, and suppliers of materials that are unique to ABC needs to be undertaken. This outreach could be included in the mission of the center discussed in the preceding recommendation.

Expand FHWA HfL and IBRD Programs

Despite the widespread enthusiasm and effort on the part of state DOTs to promote and expand the use of ABC, many barriers remain, especially because of uncertainty and the perceived financial risk that ABC might pose to bridge owners and contractors. The hesitation to use ABC becomes even more pronounced when advanced materials and techniques are utilized in the bridge. Demonstration projects funded through FHWA's HfL and IBRD programs can greatly help to reduce the hesitation and increase the comfort level in adoption of ABC. These programs should expand to support more demonstration projects utilizing various ABC connection techniques and help showcase successful ABC design and implementation, with the ultimate goal of promoting ABC in areas where extreme loads are prevalent.

Expand Research on Emulative ABC Connections Under Extreme Loads

The scan revealed that state DOTs are more willing to embrace emulative ABC connections than other types. Except for the limited data on the seismic performance of emulative ABC connections obtained in recent years, data for ABC connection performance under extreme loads are scarce. Research results on emulative ABC connection behavior not only under seismic loads, but also on other load types, are needed before the results can be implemented in the AASHTO specifications.

Support Research on ABC Connections with Unconventional Materials

Emulative design may be the most appropriate initial focus for codifying ABC connections. However, use of innovative details, high-performance grouts, concrete, metals, and composite materials should be considered for future development. Innovative methods and materials have the potential to exceed the target performance levels of emulative design. Therefore, research on ABC connections with emerging technologies and high-performance materials should continue and their performance under MH loading and their long-term performance should be studied.

Collect, Organize, and Disseminate Field Data on ABC Connections

Frequent field investigation and inspection of ABC projects should be conducted, performance data documented, and lessons learned identified until a sufficiently large database of the field performance of ABC connections is compiled. This effort can be undertaken in collaboration with FHWA's Long-Term Bridge Performance monitoring program⁶⁸ to utilize the tools and processes that have become available in recent years. The information needs to be thoroughly documented, highly organized, and in searchable electronic materials for effective access by ABC stakeholders.

Expand AASHTO Seismic Guide Specifications for Implementation of ABC

Understanding the effects of extreme load on bridges is at different levels of maturity depending on the load types. Extensive research over the past few decades has made substantial information on seismic load effects available and has led to the development of the AASHTO Guide Specifications for LRFD Seismic Bridge Design, which reflects the state-of-the-art. Yet even this document does not address design of ABC connections for areas of moderate and high seismicity. It is recommended that this document be expanded to address provisions for seismic design of ABC connections in SDCs B, C, and D.

⁶⁸ LTBP: Long-Term Bridge Performance Program, FHWA,
<http://www.fhwa.dot.gov/research/tfhrc/programs/infrastructure/structures/ltpb/>

Perform Research on High-Early-Strength Concrete and Grouts and Develop Design and Construction Specifications

High-early-strength concrete and grouts are essential materials for successful implementation of ABC connections. Significant research on these materials has been conducted. As a result, high-early-strength concrete and grouts have been utilized in closure pours and other connections in many bridges.

Systematic field monitoring of existing materials needs to be undertaken, and research should continue to address issues observed in the field and develop reliable and practical mixes and construction processes. It is recommended that the research and field data be synthesized and implemented in design and construction guide specifications for high-early-strength concrete and grouts.

Develop Guidelines for Shipment and Erection of Prefabricated Components

A wide variety of sizes and weights prefabricated bridge components can be used in ABC. Currently engineers have to perform potentially extensive calculations to optimize the transport and erection of prefabricated components. A considerable amount of information is needed with respect to truck dimensions, weight limits, permissible component sizes, and other constraints, some of which might be specific to the shipping routes and to the site of the bridge to be constructed.

To help expedite the planning for transporting and erecting ABC components, it is recommended that general guidelines be developed for integrating all the relevant information in one document.

Implementation Plan

The scan team proposes to undertake the following actions to implement the items discussed in the Recommendations section.

- Present seminars and webinars summarizing the scan’s findings and recommendations at venues frequented by bridge engineers, contractors, material suppliers, and fabricators. These venues include:
 - ◆ AASHTO Bridge Subcommittee meetings
 - ◆ Transportation Research Board (TRB) annual meetings
 - ◆ TRB international bridge conferences
 - ◆ International Bridge Conference⁶⁹
 - ◆ NCHRP 20-68A⁷⁰ and B⁷¹ project websites
 - ◆ Technical committees in ASCE, ACI, PCI, PTI, and the Florida International University ABC Center, among others
- Follow up with various relevant AASHTO bridge subcommittees to take action to implement the scan team’s recommendations and identify champions within these subcommittees for this purpose.
- Express support to FHWA upper management for the organization’s ongoing study on MH loading.
- Help develop a problem statement for AASHTO consideration on performance-based design of emulative and non-emulative ABC connections. Coordinate with the current NCHRP 20-05⁷² project on performance-based design.
- Help formulate a problem statement for a national center on MH loading design of ABC elements, connections, and structures.

69 The International Bridge Conference, Engineers’ Society of Western Pennsylvania, <http://eswp.com/bridge/>

70 NCHRP 20-68A, U.S. Domestic Scan Program, <http://apps.trb.org/cmsfeed/TRBNetProjectDisplay.asp?ProjectID=1570>

71 NCHRP 20-68B, Accelerating Rate of Innovation Among State DOTs, <http://apps.trb.org/cmsfeed/TRBNetProjectDisplay.asp?ProjectID=2657>

72 NCHRP 20-05, Synthesis of Information Related to Highway Problems, <http://apps.trb.org/cmsfeed/TRBNetProjectDisplay.asp?ProjectID=507>

- Develop technical articles summarizing the scan team's findings and recommendations for publication in TRB's *Transportation Research Record* and other professional journals.
- Form an ABC user group with membership comprising state engineers, designers, contractors, researchers, federal officials, suppliers, and fabricators. Hold regular virtual meetings to exchange ideas and share lessons learned.
- Interact with FHWA and other organizations to help implement the scan recommendations.

APPENDIX A: SCAN TEAM CONTACT INFORMATION

Scan Team Contact Information

Jugesh Kapur, PE, SE; AASHTO Chair

State Bridge Engineer
Washington State DOT
Bridge & Structures Office
PO Box 47340
Olympia, WA 98504-7340
Phone: (360) 705-7207
E-mail: kapurju@wsdot.wa.gov

Alexander K. Bardow, PE

Director of Bridge and Structures
Massachusetts Highway Department
10 Park Plaza, Suite 6430
Boston, MA 02116-3973
Phone: (617) 973-7571
Fax: (617) 973-7554
E-mail: alexander.bardow@mhd.state.ma.us

Waseem Dekelbab, PhD, PE; TRB Liaison

Senior Program Officer
Transportation Research Board
TRB Mail Room
500 Fifth Street, NW
Washington, DC 20001
Phone: (202) 334-1409
Fax: (202) 334-2006
E-mail: wdekelbab@nas.edu

Michael Keever, PE

California Department of Transportation
Office of Earthquake Engineering
1801 30th Street
Sacramento, CA 95816
Phone: 916-227-8806
E-mail: mike_keever@dot.ca.gov

Mehdi Saiid Saiidi, PhD, PE, FACI, FASCE; Subject Matter Expert

Department of Civil and Environmental Engineering

Mail Stop 258

University of Nevada, Reno

Reno, NV 89557

Phone: (775) 784-4839, (775) 784-8226

Fax: (775) 784-1390

Email: saiidi@unr.edu

Joshua Sletten, SE

Structures Design Manager

Utah Department of Transportation

4501 South 2700 West

PO Box 148470

Salt Lake City, UT 84114

Phone: (801) 965-4879

E-mail: jsletten@utah.gov

Daniel H. Tobias, PhD, PE, SE

Bridges and Structures

Illinois Department of Transportation

2300 S. Dirksen Parkway

Springfield, IL 62764-0002

Phone: (217) 782-2912

E-mail: daniel.tobias@illinois.gov

W. Phillip Yen, PhD, PE

Principal Bridge Engineer–Structural Dynamics

Office of Bridge Technology HIBT-1/Room E73-421

Federal Highway Administration

1200 New Jersey Avenue SE

Washington, DC 20590

Phone: (202) 366-5604

E-mail: pyen@dot.gov

APPENDIX B: SCAN TEAM BIOGRAPHICAL SKETCHES

Scan Team Biographical Sketches

JUGESH KAPUR (AASHTO CHAIR) is the State Bridge and Structures Engineer for Washington State, where he provides direction, guidance, and management to the structural engineering program with the assistance of 120 individuals in Washington State DOT's Bridge and Structures Office. He has implemented in the agency many ABC practices designed for seismic loads. Prior to this position, Kapur was the State Bridge Design Engineer, Design Unit Manager. He also worked in the private sector for eight years. Kapur is a University of Washington graduate and a registered professional engineer in civil and structural engineering in Washington and Oregon.

ALEXANDER K. BARDOW is the State Bridge Engineer for the Massachusetts DOT (MassDOT). In this position, he oversees the Technical Services Unit of the Bridge Section, which includes the Bridge Inspection, Ratings and Overloads, Metals Control, and Geotechnical and Hydraulic Units. He also oversees the development of MassDOT bridge design policy and standard details and standard specifications for bridge construction. Bardow is a member of the AASHTO Subcommittee on Bridges and Structures, the chair of its Technical Committee for Welding, vice chair of its Technical Committee for Timber, and a member of its Technical Committees for Seismic Design, Guardrail and Bridge Rail, and Tunnels. He is also a member of several National Cooperative Highway Research Program (NCHRP) Project Panels. A member of the American Society of Civil Engineers, he is a past president of the organization's Boston Society of Civil Engineers Section. Bardow received his BSCE and MSCE degrees from MIT and is a registered professional engineer in Massachusetts.

WASEEM DEKELBAB joined the National Academies in November 2008 as a Sr. Program Officer responsible for managing bridge and structural-related research projects that aim to propose standards, guidelines, and specifications for AASHTO. His last assignment was with Science Applications International Corporation in contract with FHWA to work on-site at the Turner-Fairbank Highway Research Center as principal investigator of the Bridge Management Information Systems laboratory supporting the Long-Term Bridge Performance Program. Dekelbab holds bachelor's, master's, and doctoral degrees in civil engineering; is a licensed professional engineer in several states; and is a certified Project Management Professional.

MICHAEL KEEVER is the Chief of the Caltrans Office of Earthquake Engineering, Analysis & Research in Sacramento, California. He is responsible for developing seismic design specifications and details for new bridge designs and retrofitting existing bridges; managing university structural and seismic research; conducting complex structural analysis; interacting with seismic peer review consultants and the Caltrans Seismic Advisory Board; and coordinating post-earthquake bridge damage investigations. Keever is a member of the Caltrans Accelerated Bridge Construction Steering Committee, chair of the Caltrans Executive Earthquake Committee, chair of the TRB AFF50 Seismic Design and Performance of Bridges Committee, and a member of the AASHTO T-3 Seismic Design Committee. He is a graduate of the University of Southern California and is a licensed professional engineer in California.

MEHDI SAID SAIDI (SUBJECT MATTER EXPERT) is a professor at the Civil and Environmental Engineering Department and the Director of Center for Advanced Technology for Bridges and Infrastructure at the University of Nevada, Reno. He has more than 34 years of experience in earthquake engineering research, mostly on bridges; has published more than 425 technical papers and reports; and has given more than 300 technical presentations, many as an invited guest and a keynote speaker. Saiidi has conducted research with funding from NSF, FHWA, Caltrans, NCHRP, the Nevada DOT, and private industries. Saiidi received a master's degree in civil engineering from Tehran University in 1973 and master's and doctoral degrees in structural engineering from the University of Illinois at Urbana-Champaign in 1977 and 1979, respectively. He joined the University of Nevada, Reno upon graduation. He served as the chair of the Civil and Environmental Engineering Department from 1986 to 1994 and served as the inaugural director of the university-wide Office of Undergraduate Research from 2003 to 2009. A registered professional engineer in California and Nevada, Saiidi is a Fellow of ASCE and ACI and is the founding and past chairman of ACI Committee 341, Earthquake-Resistant Concrete Bridges. He is a member of ACI Subcommittee 318, Flexure and Axial Loads, and several other technical committees and several other ACI committees. Saiidi has received many awards, including the UNR Outstanding Researcher Award, Foundation Professorship Award, Nevada Regents Researcher Award, the University of Illinois at Urbana-Champaign Distinguished Alumni Award, and the Lemelson Innovation Award.

JOSHUA J. SLETTEN has been the Structures Design Manager for Utah DOT's Structures Division since June 2009. In this capacity, he oversees all in-house structure design projects; supervises owner oversight of all consultant structure designs; maintains structural standards, specifications, typical details and manuals; and assists the chief structural engineer with key programs and initiatives, such as ABC. Since moving to Utah in 2007, he has been intently involved with all aspects of ABC, including planning, program implementation, project execution and design, program evaluation, and training. Prior to working at Utah DOT, Sletten spent eight years working as a bridge design engineer and project manager for the transportation engineering consultants LJB, Inc., in Dayton, Ohio, and HNTB Corp. in Salt Lake City, Utah. He is a member of the AASHTO Subcommittee on Bridges and Structures and serves on the Technical Committee for Software and Technology (T-19). He earned a bachelor's degree in civil engineering from the South Dakota School of Mines and Technology in 2001 and a master's degree in structural engineering from Purdue University in 2002.

DANIEL TOBIAS is a structural development and precast and prestressed construction engineer with the Illinois DOT. He is also an adjunct faculty member in structural engineering for the Department of Civil Engineering at St. Louis University and an associate editor of the American Society of Civil Engineer's *Journal of Bridge Engineering*. Tobias' career spans a broad range of experiences in structural and bridge engineering. In recent years, his focus has been on projects related to implementation of the AASHTO LRFD Code in Illinois; development and refinement of Illinois DOT's Earthquake Resisting System strategy; development and refinement of the seismic provisions for the AASHTO LRFD Code and AASHTO Guide Specifications, as well as numerous revisions in other areas of the AASHTO LRFD Code; and research, development, and implementation efforts for integral abutment bridges, drilled shafts, H-piles, HPC for bridge decks, and retrofitting

methods for wood piles, including glass-fiber reinforced polymer Tobias received a bachelor's degree in civil engineering from Virginia Tech and master's and doctoral degrees in structural engineering from the University of Illinois at Urbana-Champaign. He is a licensed professional engineer and a licensed structural engineer in Illinois.

W. PHILLIP YEN is the Principal Bridge Engineer in Structural Dynamics of the FHWA Office of Bridge Technology and the former Program Manager of the FHWA Seismic Hazard Mitigation Program of the Office of Infrastructure R&D. He is responsible for enhancing and implementing bridge technology in all extreme events related to structural dynamics and has the technical responsibility to conduct earthquake engineering research in highway construction. He is currently directing/managing three major FHWA seismic research projects with a budget of more than \$12.5 million. Yen was a voting committee member of AASHTO's new seismic design code development. He is FHWA's representative on the National Earthquake Loss Reduction Program; and is chairing the fifth and sixth annual National Seismic Conferences for Bridges and Highways; chaired the fourth and fifth annual technical committee of the NSC; and chairs FHWA's National Seismic Engineering Team. Yen also served as a steering committee member for the Mid-America Seismic Conference for Highways. He received his master's and doctoral degrees in civil engineering from the University of Virginia and is a registered professional engineer in Virginia.

APPENDIX C: HOST AGENCY KEY CONTACTS

Host Agency Key Contacts

California

Michael Keever

California Department of Transportation
Office of Earthquake Engineering
1801 30th Street
Sacramento, CA 95816
Phone: (916) 227-8806
E-mail: mike_keeveer@dot.ca.gov

Florida

Sam Fallaha, PE

Assistant State Structures Design Engineer
FDOT- Structures Research Center
2007 E. Paul Dirac Drive
Tallahassee, FL 32310 Phone: (850) 921-7111
E-mail: sam.fallaha@dot.state.fl.us

Thomas A. Andres, PE

Assistant State Structures Design Engineer
605 Suwannee Street, MS 33
Tallahassee, FL 32399-0450
Phone: (850) 414-4269
E-mail: thomas.andres@dot.state.fl.us

Massachusetts

Shoukry Elnahal, PE

Deputy Chief Engineer for Bridges & Tunnels
Massachusetts DOT
Ten Park Plaza, Suite 6500
Boston, MA 02116
Phone: (617) 973-7995
Fax: (617) 973-8808
E-mail: shoukry.elnahal@state.ma.us

Alexander K. Bardow, PE

Director of Bridge and Structures
Massachusetts Highway Department
10 Park Plaza, Suite 6430
Boston, MA 02116-3973
Phone: (617) 973-7571
Fax: (617) 973-7554
E-mail: alexander.bardow@mhd.state.ma.us

Eliza S. Partington

ABP Technical Coordinator
MassDOT Highway Division
Accelerated Bridge Program
10 Park Plaza, Room 6500
Boston, MA 02116
Phone: (617) 973-7225
E-mail: eliza.partington@state.ma.us

Nevada

Mehdi Saiid Saiidi, PhD, PE, FACI, FASCE

Department of Civil and Environmental Engineering
Mail Stop 258
University of Nevada, Reno
Reno, NV 89557
Phone: (775) 784-4839; (775) 784-8226
Fax: (775) 784-1390
E-mail: saiidi@unr.edu

Mark Elicegui, PE

Chief Structures Engineer
Nevada Department of Transportation
1263 South Stewart Street
Carson City, NV 89712
Phone: (775) 888-7540
Fax: (775) 888-7405
E-mail: melicegui@dot.state.nv.us

South Carolina

Lucero E. Mesa, PE

South Carolina Department of Transportation

Bridge Design Section

Seismic Design Support

955 Park Street, Room 508

Columbia, SC 29202

Phone: (803) 737-1765

Fax: (803) 737-1881

E-mail: mesale@dot.state.sc.us

Steve Nanney, PE

South Carolina Department of Transportation

Preconstruction Support-Structural Support

955 Park Street, Room 508

Columbia, SC 29202

Phone: (803) 737-1734

Fax: (803) 737-1881

E-mail: nanneysa@dot.state.sc.us

Zhugang “Amos” Liu, PE

STV/Ralph Whitehead Associates

1000 W. Morehead Street, Suite 200

Charlotte, NC 28208

Phone: (704) 372-1885

Fax: (704) 372-3393

E-mail: Amos.Liu@stvinc.com

Texas

Keith Ramsey, PE

Director of Field Operations

Bridge Division

Texas Department of Transportation

118 E. Riverside Drive

(Mailing: 125 East 11th Street)

Austin, TX 78701

Phone: (512) 416-2250

Fax: (512) 416-2105

E-mail: kramsey@dot.state.tx.us

Utah

Carmen Swanwick

Chief Structures Engineer
Utah Department of Transportation
4501 South 2700 W
PO Box 148470
Salt Lake City, UT 84119
Phone: (801) 965-4981
Fax: (801) 965-4187
E-mail: cswanwick@utah.gov

Joshua Sletten, SE

Structures Design Manager
Utah Department of Transportation
4501 South 2700 West
Box 148470
Salt Lake City, UT 84114
Phone: (801) 965-4879
E-mail: jsletten@utah.gov

Washington State

Bijan Khaleghi

State Bridge Design Engineer
Washington State DOT Bridge & Structures Office
PO Box 47340
Olympia, WA 98504-7340
Phone: (360) 705-7181
E-mail: khalegb@wsdot.wa.gov

Jugesh Kapur, PE, SE

State Bridge Engineer
Washington State DOT
Bridge & Structures Office
PO Box 47340
Olympia, WA 98504-7340
Phone: (360) 705-7207
E-mail: kapurju@wsdot.wa.gov

Amplifying Questions

Name of Respondent: _____ State: _____ Date: _____

D = Designers

C = Contractors

1. General Issues on Design for Multi-Hazard Loading

1-1 What extreme load events do you consider for your state? (D)

1-2 Do you combine them? (D)

1-3 How do you combine them? (D)

2. ABC Design for Multi-Hazard Loading

2-1 What do you consider to be ABC connections? (D & C)

2-2 Are these ABC connections used only to connect precast members or could they be used for CIP members? (D & C)

2-3 Do you have different target performance levels for ABC connections under multi-hazard loading (life safety, repairable, operational)? (D)

2-4 Do you anticipate having different target performance levels for ABC connections in the future? (D)

2-5 What cost escalations have you experienced when combining various extreme events and using ABC connections? (D)

2-6 Have you experienced cost escalation when you use ABC? (D & C)

3. Decision and Design Tools for ABC Use

3-1 Do you carry out any cost-benefit analysis of ABC, including life cycle cost analysis? (D)

3-2 Do you have published design methods specific to ABC components and connections or do you use guidelines developed by others? Are the design methods available on the web and, if so, what is the link? (D)

3-3 Do you have standard component details for ABC? If so, how did you develop these? Are these for a specific hazard type? (D)

3-4 Do you have standard connection details for ABC? If so, how did you develop these? (D)

3-5 Do you have a process to prequalify other (nonstandard) ABC component and connection details? Briefly describe the process, if any. (D)

3-6 In fabricating bridge components and connections for ABC, do you use standard fabrication and construction tolerances, such as those found in the Bridge Welding Code, PCI Manuals, etc., or do you have different tolerances in your specifications for ABC? (D & C)

3-7 Have you incorporated field adjustability of ABC connections to allow for and accommodate the compounding effects of fabrication and construction tolerances? (D & C)

4. Past ABC Application

4-1 What are the superstructure and substructure ABC connection types you use? (D & C)

4-2 What has been your experience with ABC connection field implementation? (D & C)

4-3 Have you been documenting lessons learned from field experience with ABC connection application? Is the material available? (D & C)

4-4 Has the volume of ABC change orders or claims been different than that for conventional construction? Please elaborate. (D & C).

4-5 Have you modified the ABC design and construction process based on field experience? Please explain briefly. (D & C)

4-6 How has your contracting community adapted to projects using ABC components and connections? Are they allowed to use alternative non-ABC if they meet project delivery requirement? (D & C)

4-7 Have any of your ABC bridges been subjected to multi-hazard or extreme events? If yes, has any of those events come close to the level for which these bridges were designed? If so, how did the bridges perform? (D)

5. Partnership with Industry and Research Institutions

5-1 Do you partner with any industries to develop ABC components and connection details? Please elaborate. (D & C)

5-2 Have you funded any experimental research on ABC components and connections with conventional or alternative materials? If so, are data available on the web or in print form? (D)

5-3 Do you carry out any in-house research on ABC connections? (D)

6. ABC Inspection and Maintenance

6-1 Do you have special construction inspection requirements for ABC connections? Please elaborate. (D)

6-2 Do you have in-service inspection requirements for ABC connections? Please elaborate. (D)

APPENDIX D AMPLIFYING QUESTIONS

- 6-3 Do you have a process to carry out post-event inspections to determine damage and establish if the ABC connections performed as intended? Please elaborate. (D)
- 6-4 Have you had any concerns or issues with durability of ABC components or connections? How do you address these issues? Please elaborate. (D)
- 6-5 Have you had specific maintenance issues and procedures for bridges built using ABC? (D)
- 6-6 Have you performed repair or rehabilitation of ABC connections or components? (D & C)