

**APPENDIX E:
SITE-SPECIFIC INSTRUMENTATION PLANS**

SHEET NOTES:

REVISIONS:

NO.	DATE	BY	DESCRIPTION

DESIGNED BY: _____
DRAWN BY: _____
CHECKED BY: _____
DATE: _____
PROJECT NO.: _____
SHEET TITLE:
**CALIFORNIA, BARSTOW
INSTRUMENTATION
PLAN**

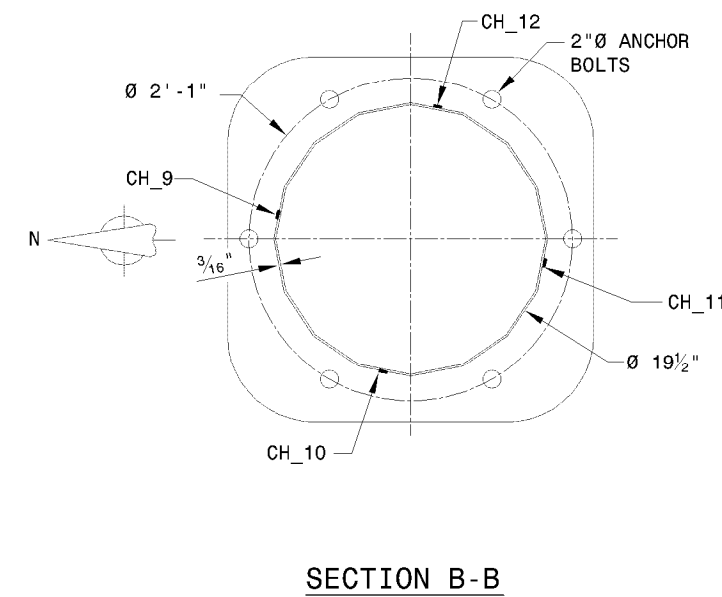
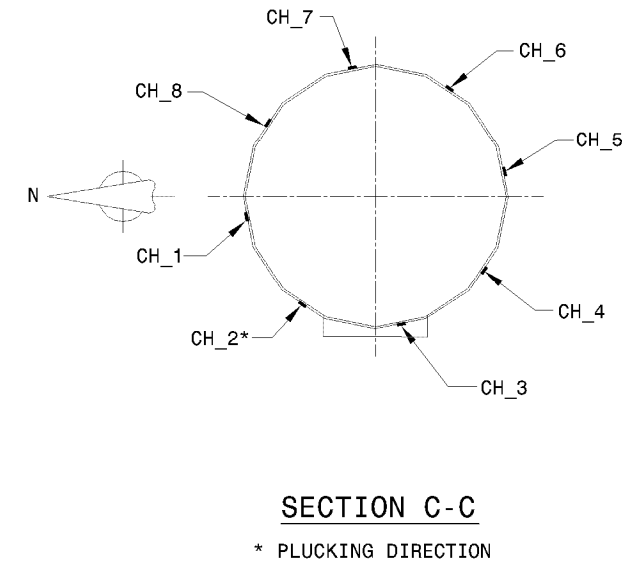
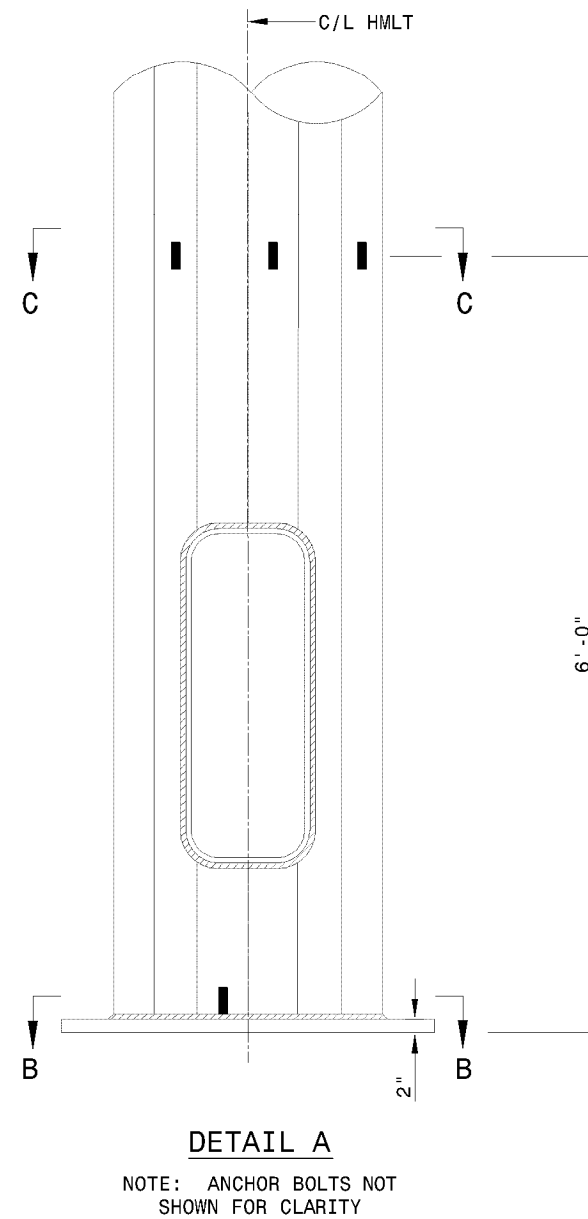
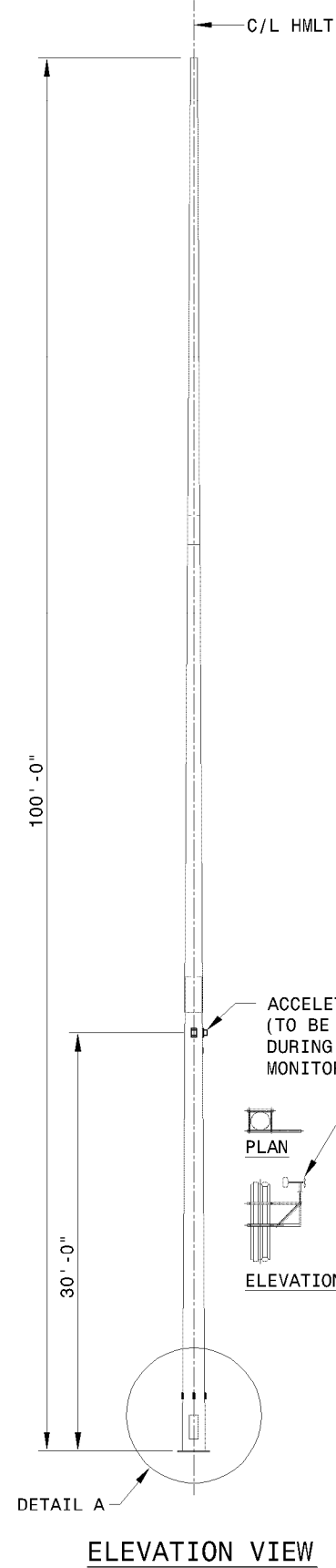

SHEET NOTES:

REVISIONS:

NO.	DATE	BY	DESCRIPTION

DESIGNED BY:

DRAWN BY:

CHECKED BY:

DATE:

PROJECT NO.:

SHEET TITLE:

**IOWA NORTH
INSTRUMENTATION
PLAN**

SHEET NO.:

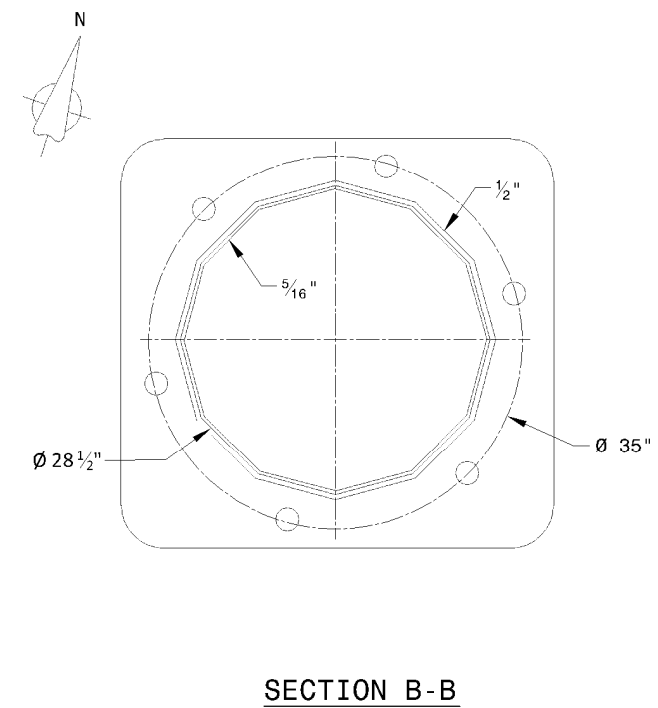
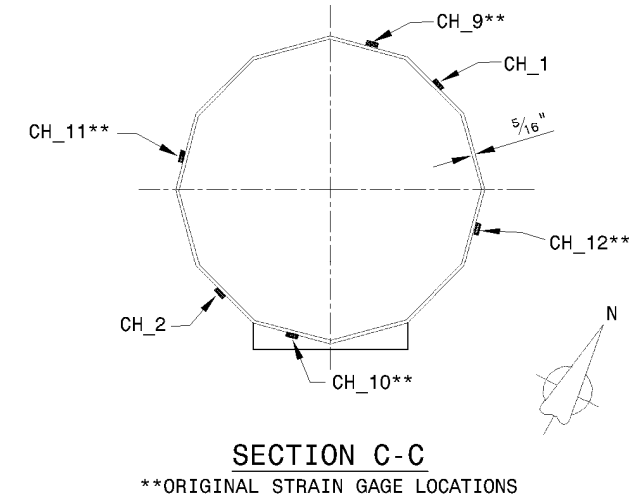
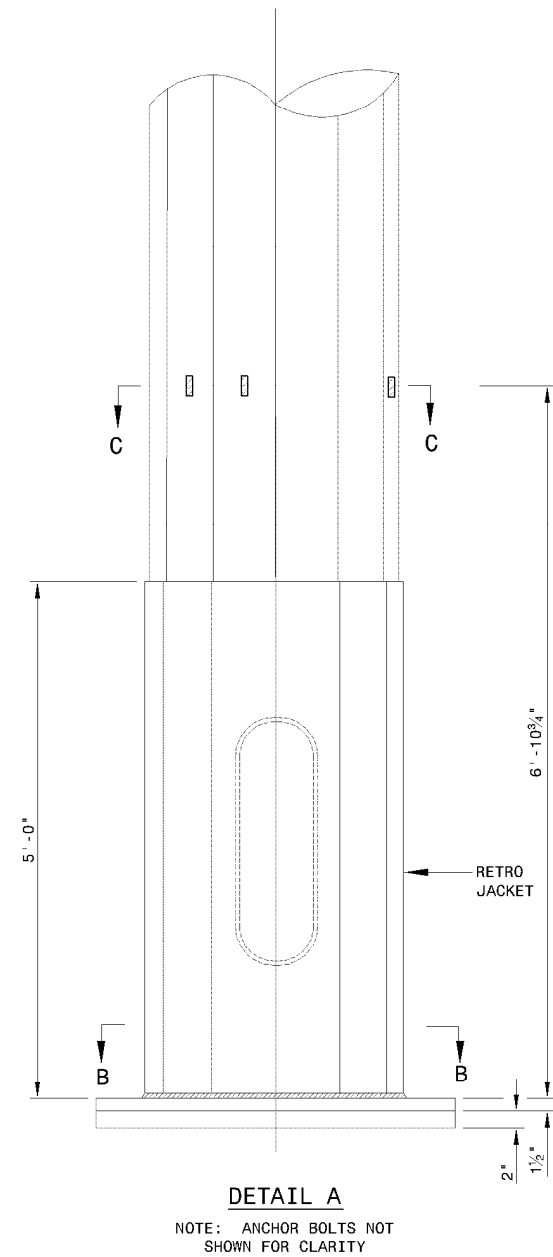
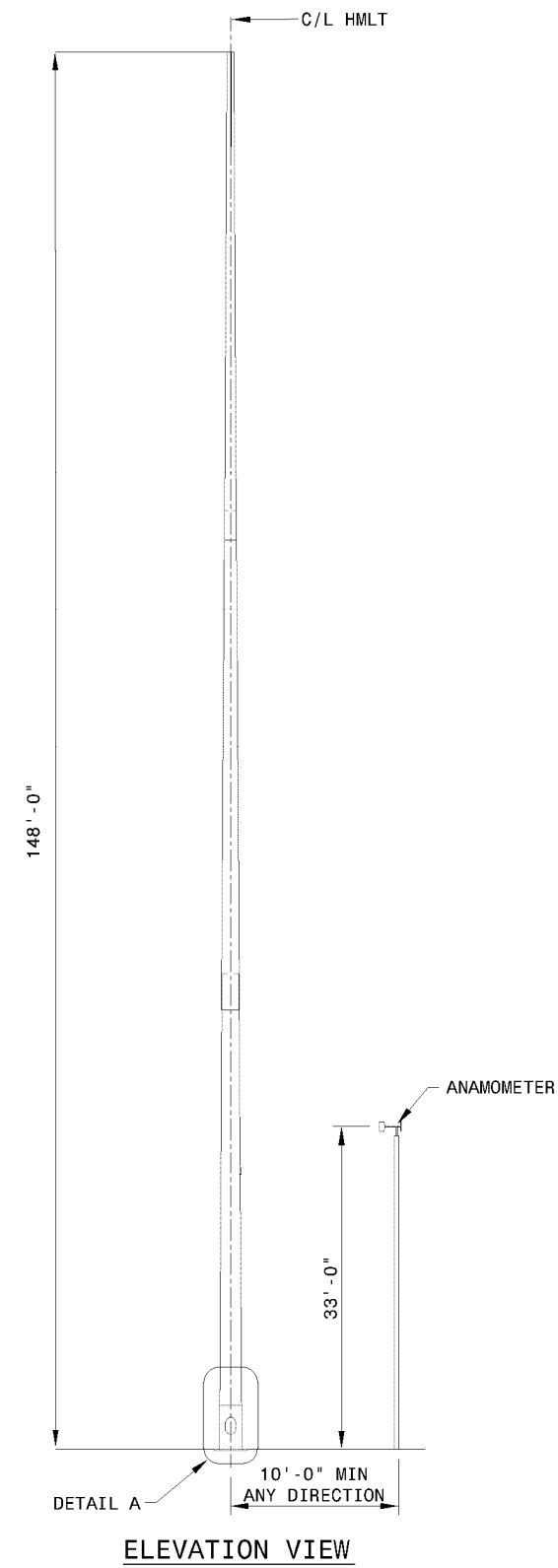

SHEET NOTES:

REVISIONS:

NO.	DATE	BY	DESCRIPTION

DESIGNED BY: _____
DRAWN BY: _____
CHECKED BY: _____
DATE: _____
PROJECT NO.: _____
SHEET TITLE:
**IOWA SOUTH
INSTRUMENTATION
PLAN**

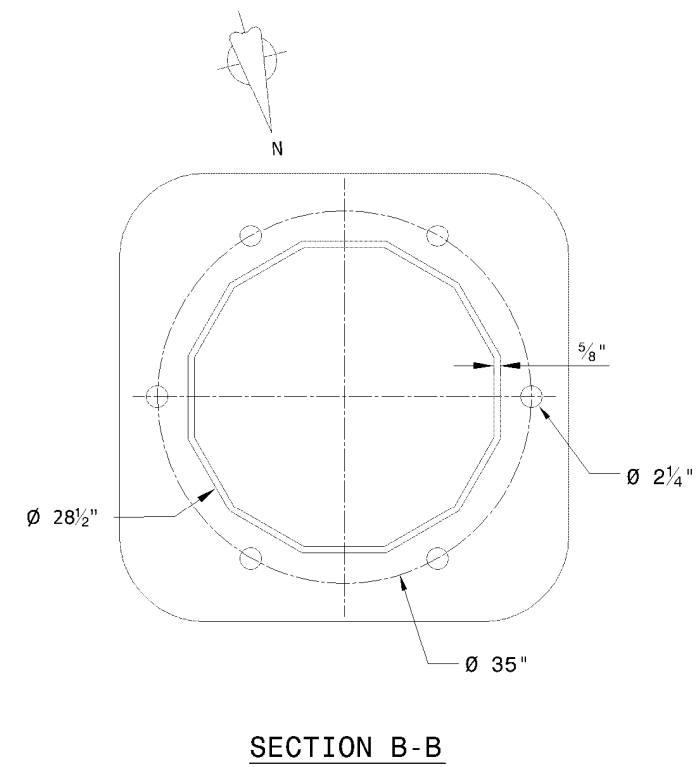
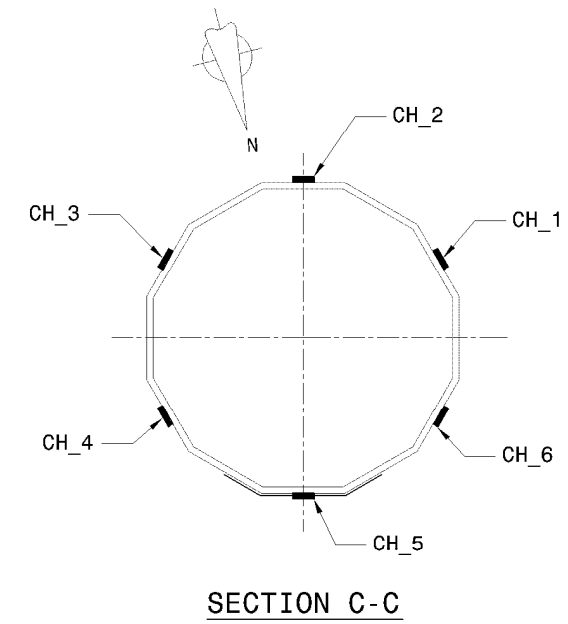
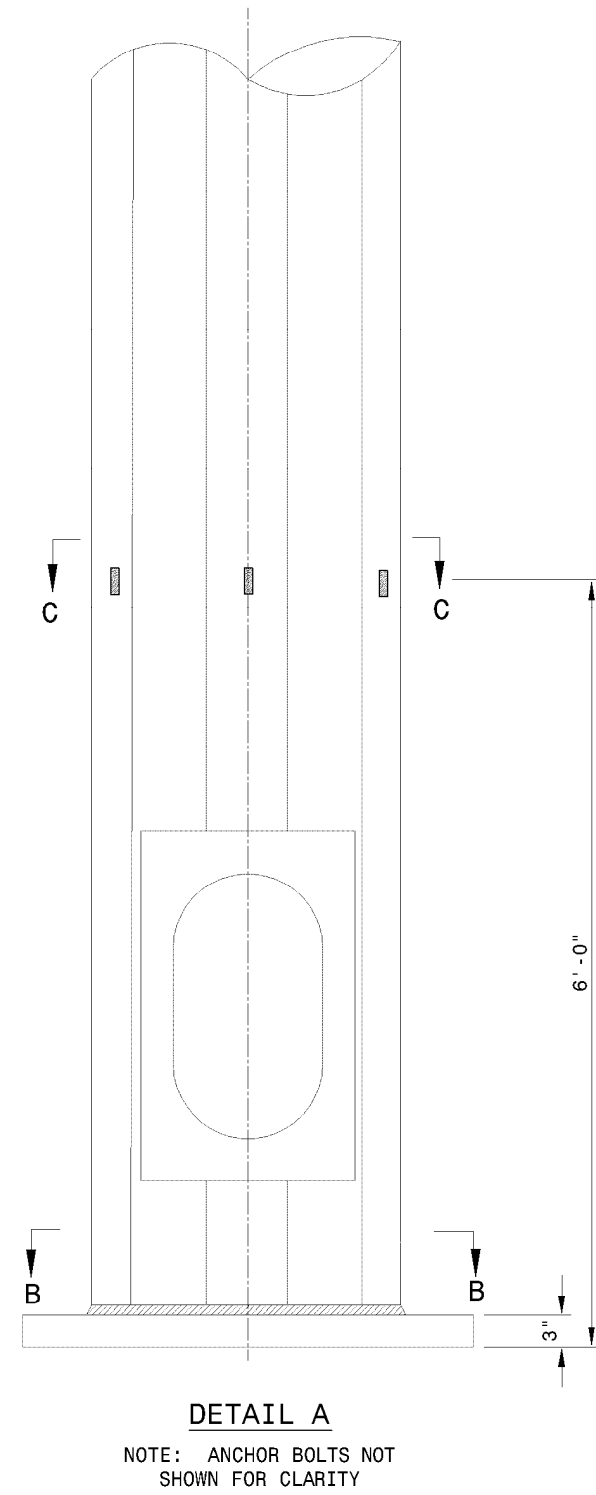
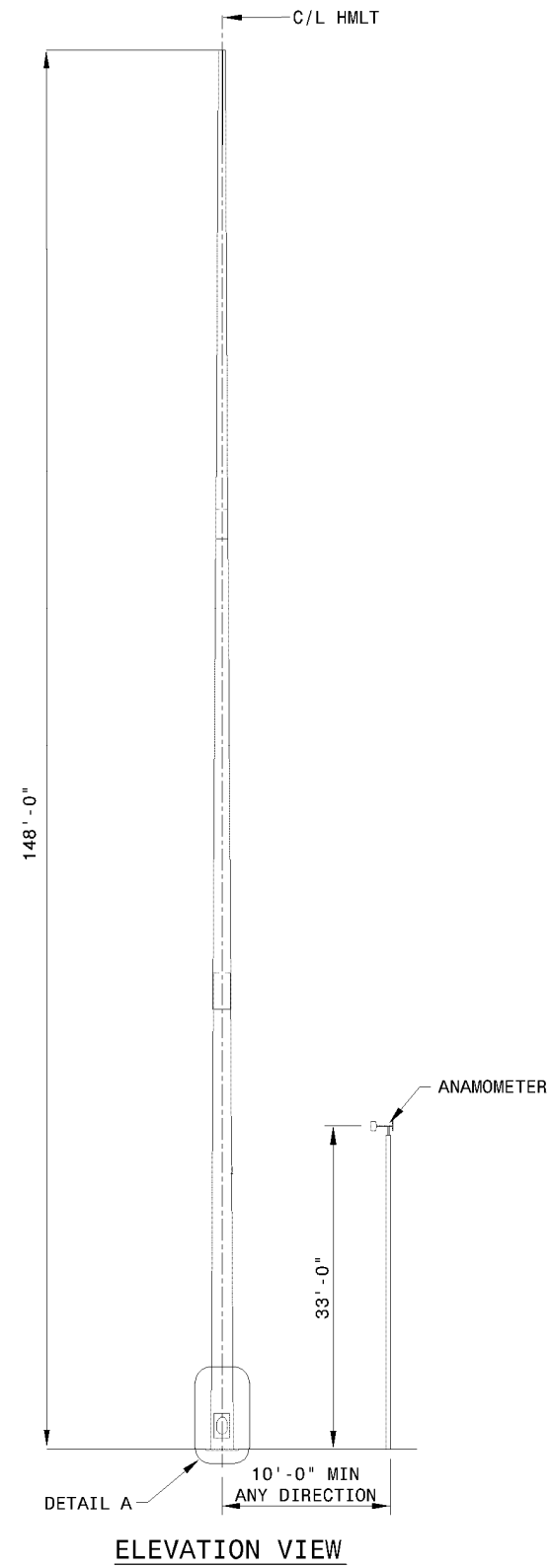

SHEET NOTES:

REVISIONS:

NO.	DATE	BY	DESCRIPTION

DESIGNED BY: _____
DRAWN BY: _____
CHECKED BY: _____
DATE: _____
PROJECT NO.: _____
SHEET TITLE: _____

KANSAS
INSTRUMENTATION
PLAN

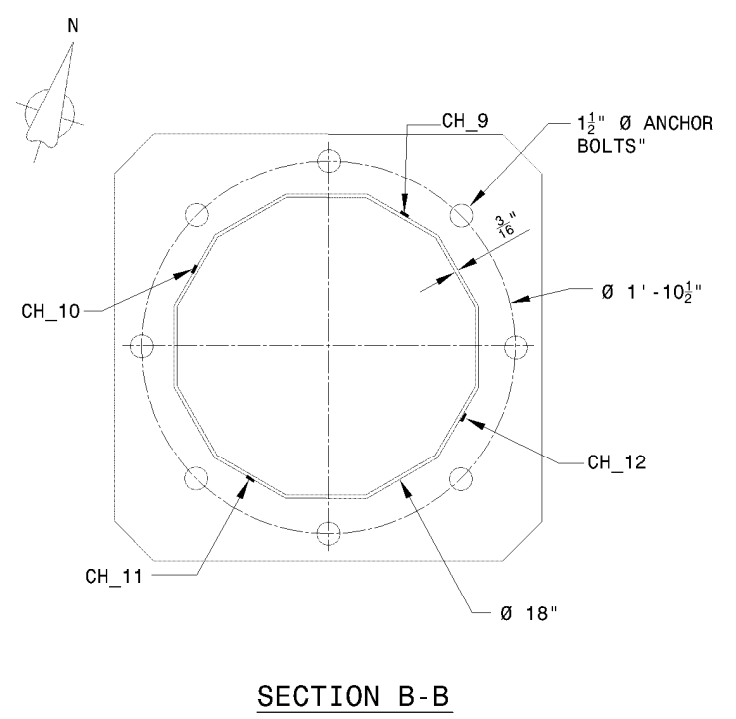
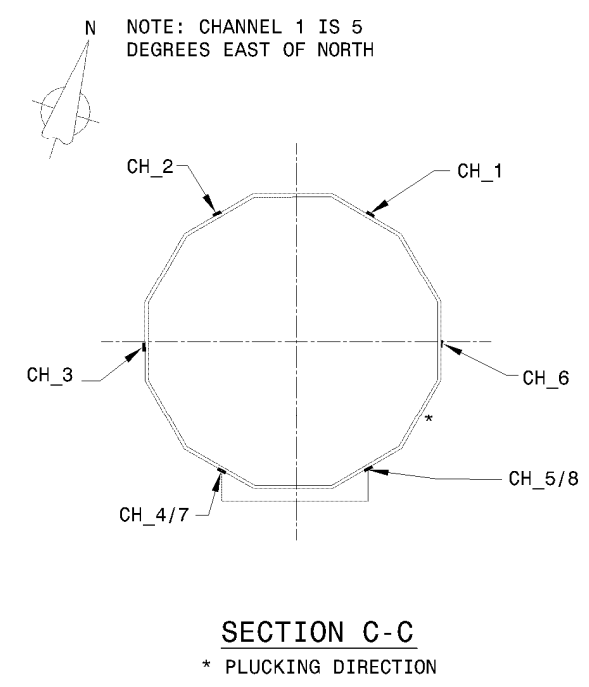
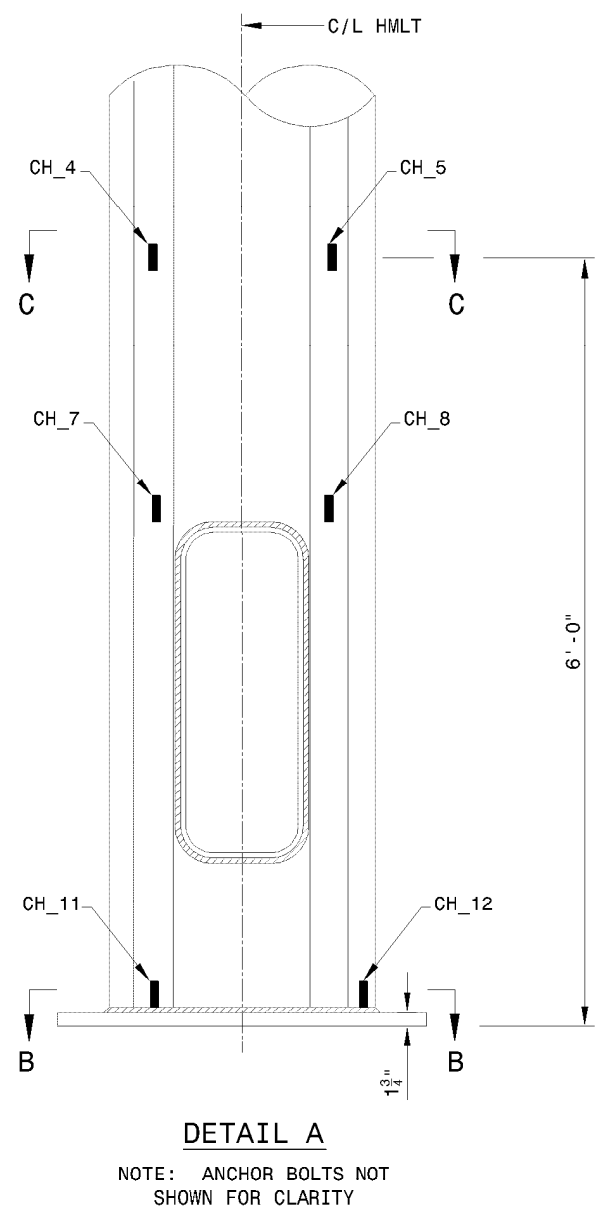
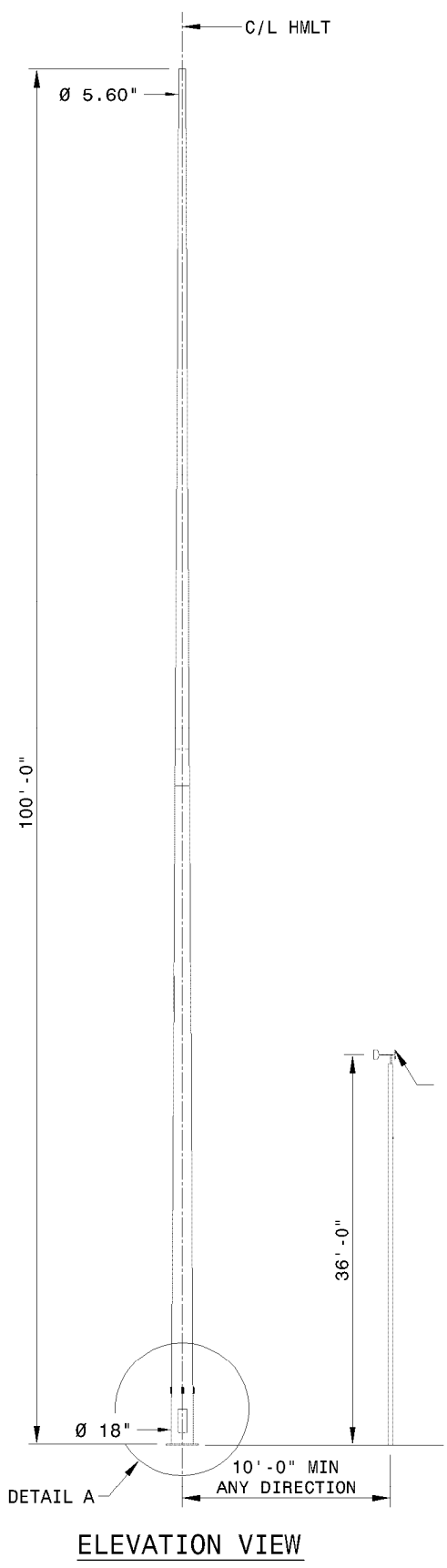

SHEET NOTES:

REVISIONS:

NO.	DATE	BY	DESCRIPTION

DESIGNED BY:

DRAWN BY:

CHECKED BY:

DATE:

PROJECT NO.:

SHEET TITLE:

**NORTH DAKOTA
INSTRUMENTATION
PLAN**

SHEET NO.:

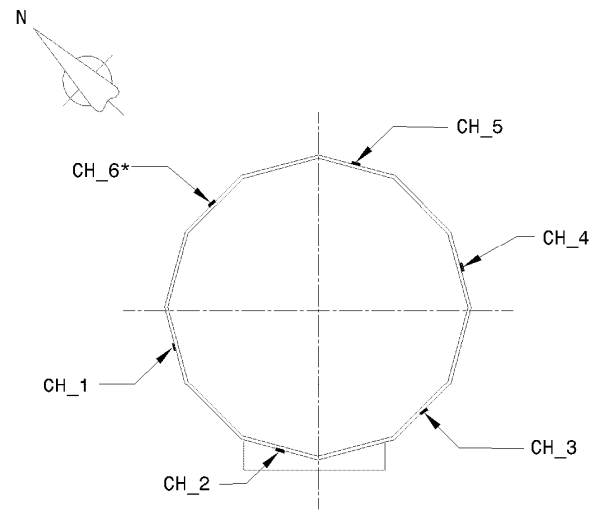
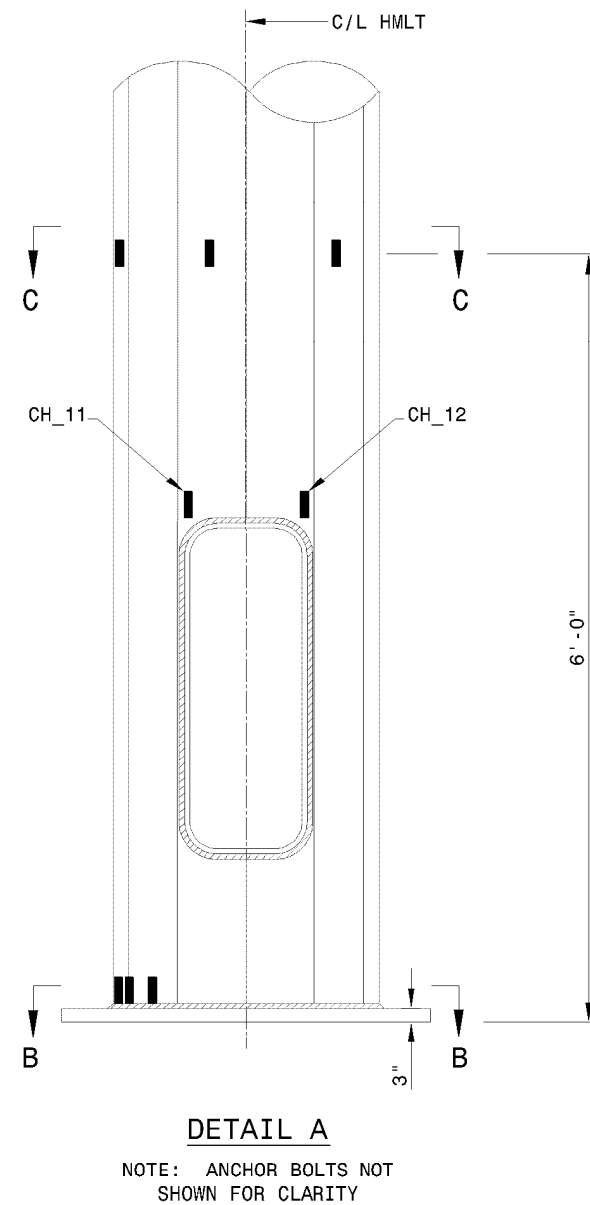
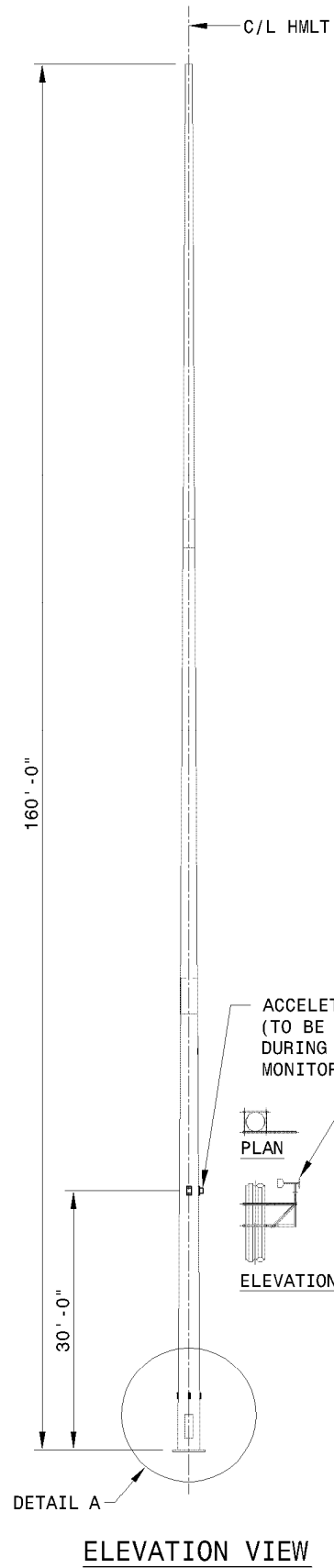

SECTION C-C
* PLUCKING DIRECTION

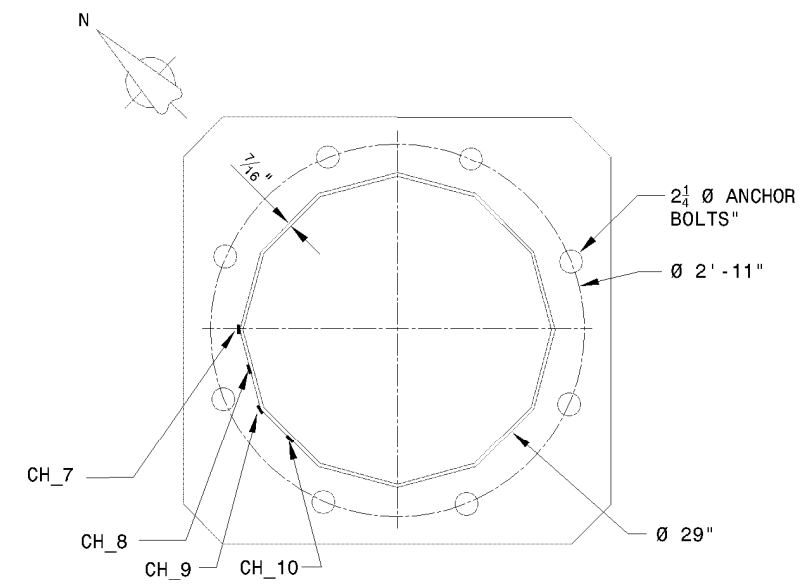

SECTION B-B

SHEET NOTES:

REVISIONS:

NO.	DATE	BY	DESCRIPTION

DESIGNED BY: _____
DRAWN BY: _____
CHECKED BY: _____
DATE: _____
PROJECT NO.: _____
SHEET TITLE: _____

**OKLAHOMA NE
INSTRUMENTATION
PLAN**

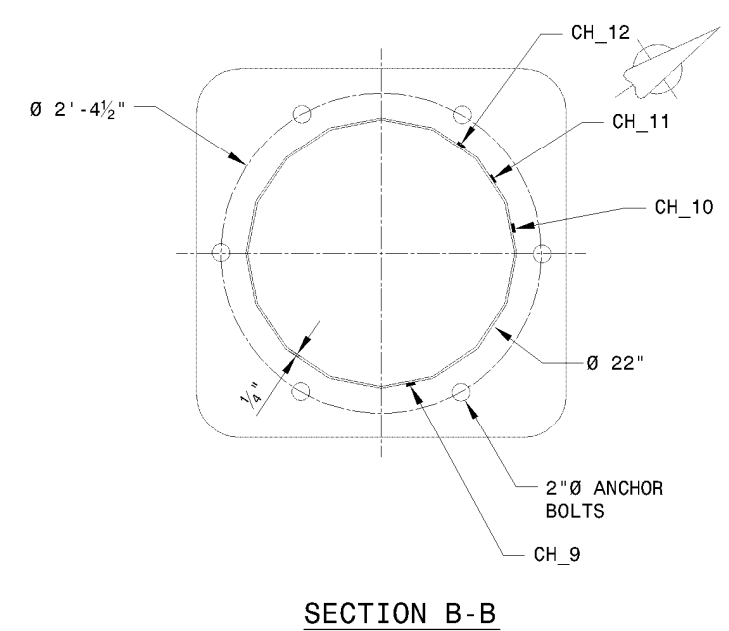
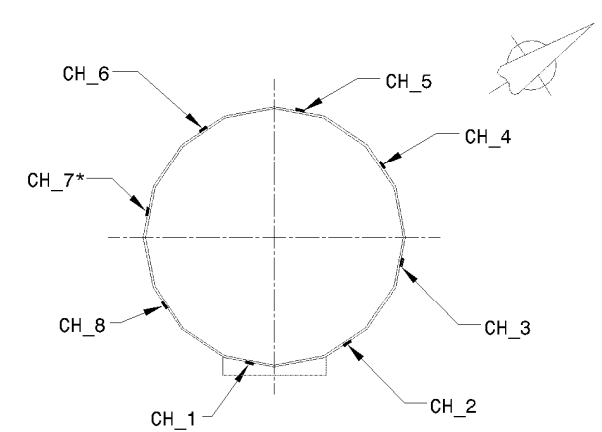
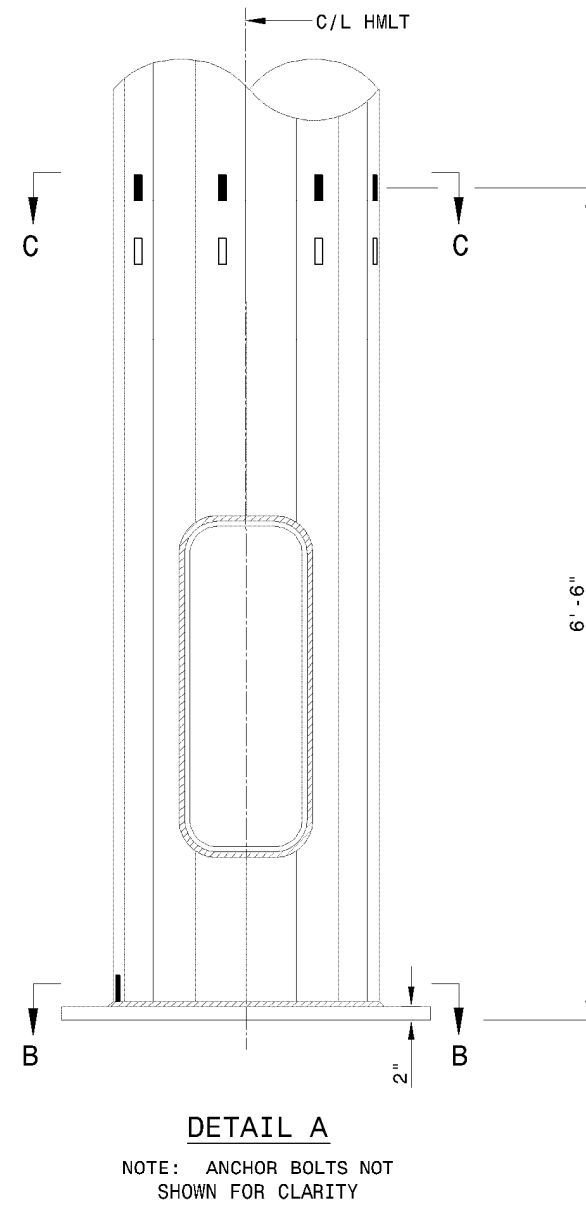
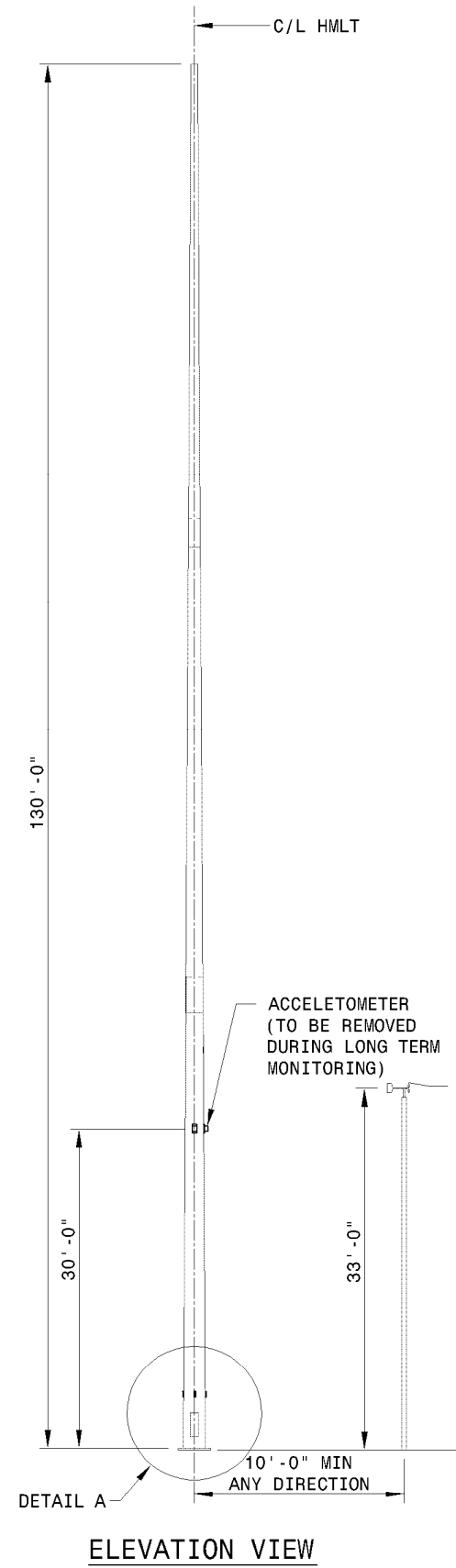

SHEET NOTES:

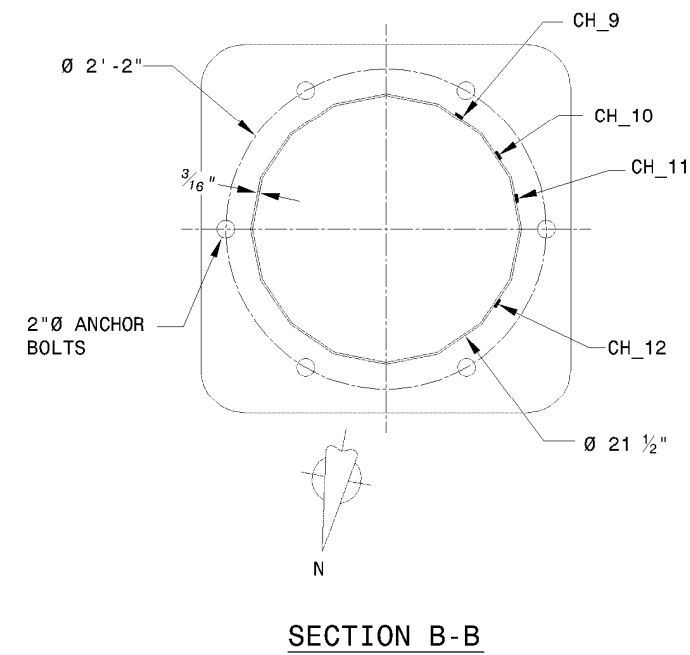
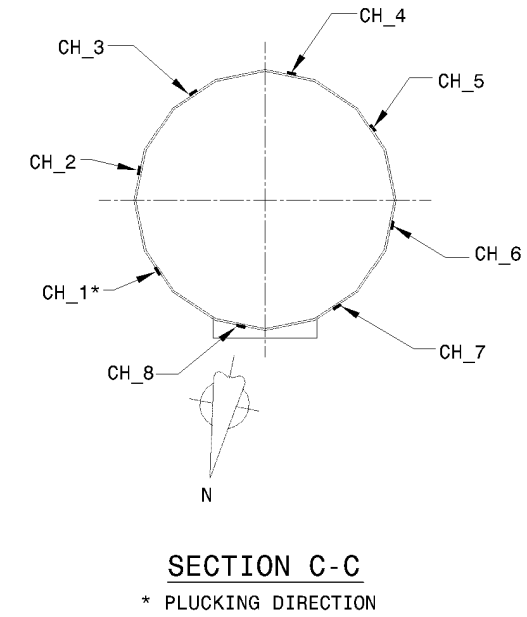
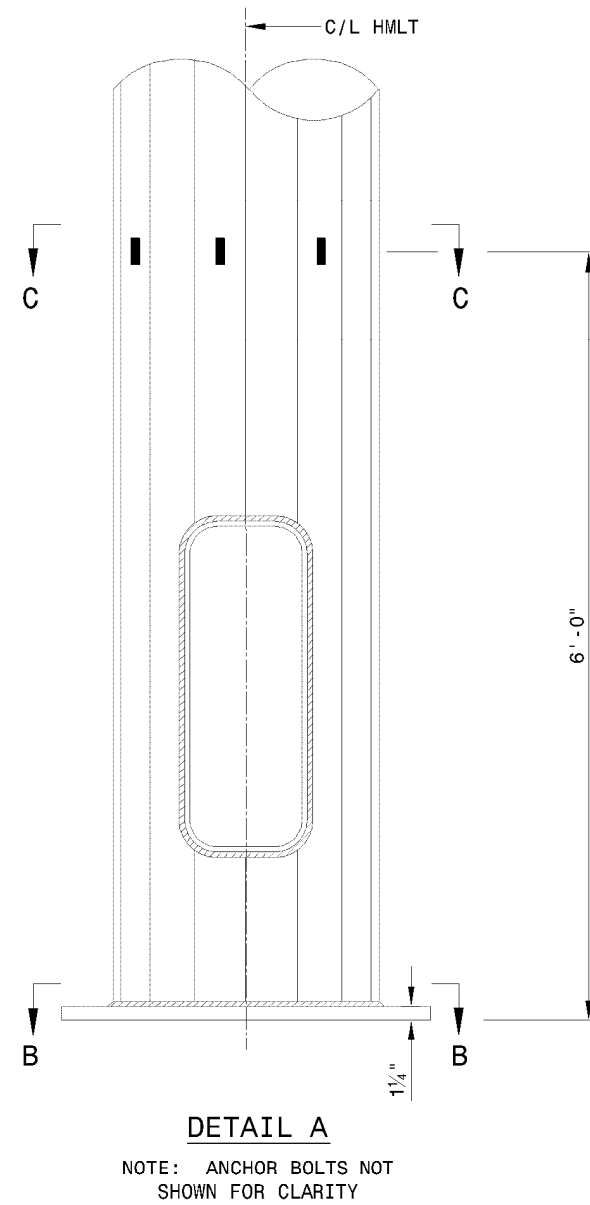
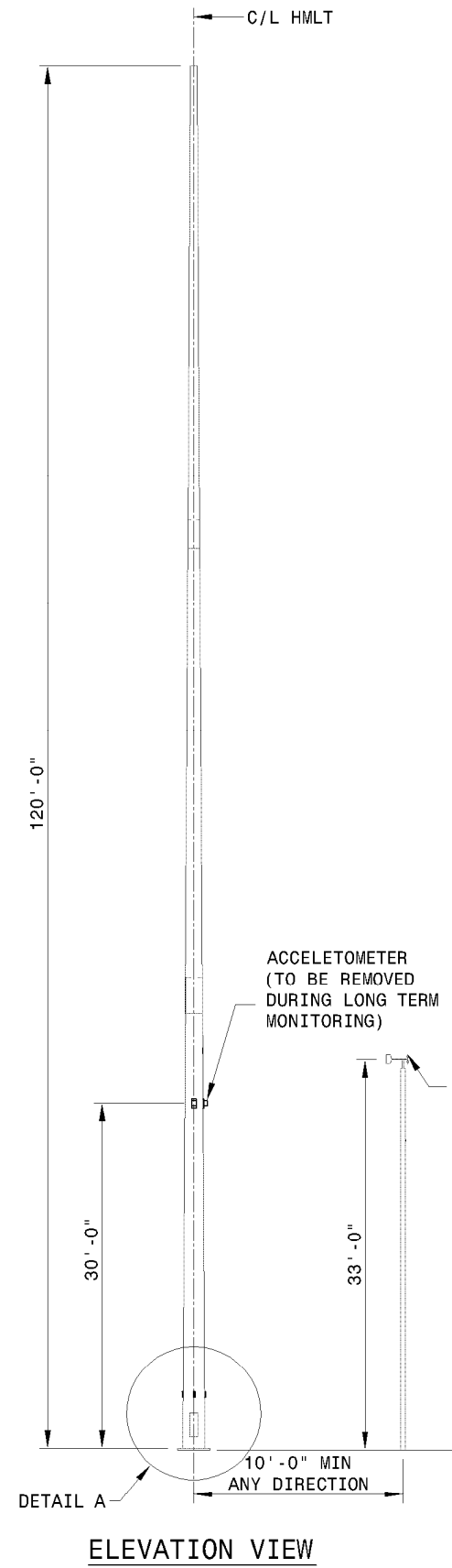

REVISIONS:

NO.	DATE	BY	DESCRIPTION

DESIGNED BY: _____
 DRAWN BY: _____
 CHECKED BY: _____
 DATE: _____
 PROJECT NO.: _____
 SHEET TITLE:
**OKLAHOMA SW
 INSTRUMENTATION
 PLAN**

SHEET NOTES:

REVISIONS:

NO.	DATE	BY	DESCRIPTION

DESIGNED BY: _____
 DRAWN BY: _____
 CHECKED BY: _____
 DATE: _____
 PROJECT NO.: _____
 SHEET TITLE:

**PENNSYLVANIA
 INSTRUMENTATION
 PLAN**

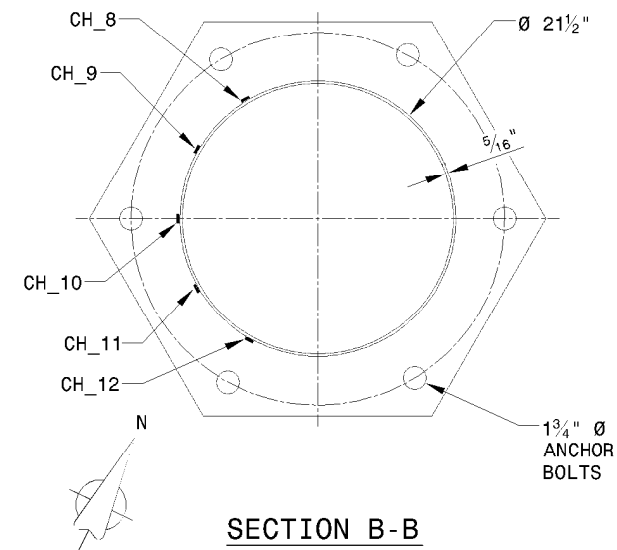
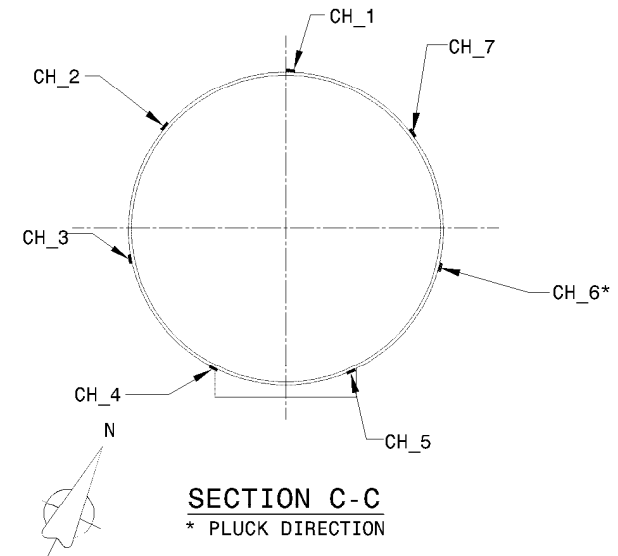
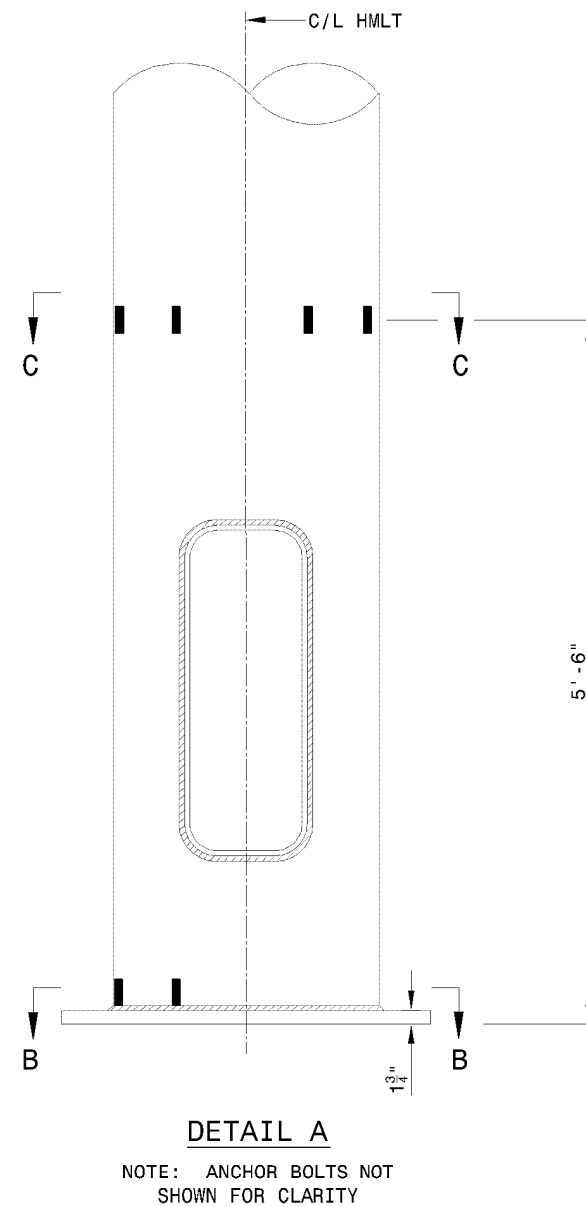
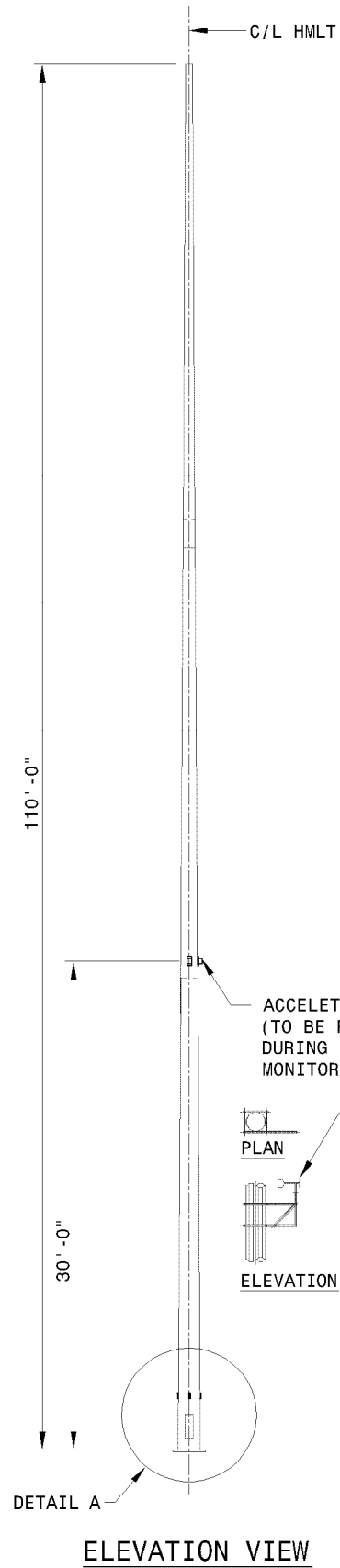

SHEET NOTES:

REVISIONS:

NO.	DATE	BY	DESCRIPTION

DESIGNED BY: _____
DRAWN BY: _____
CHECKED BY: _____
DATE: _____
PROJECT NO.: _____
SHEET TITLE:
**SOUTH DAKOTA
INSTRUMENTATION
PLAN**

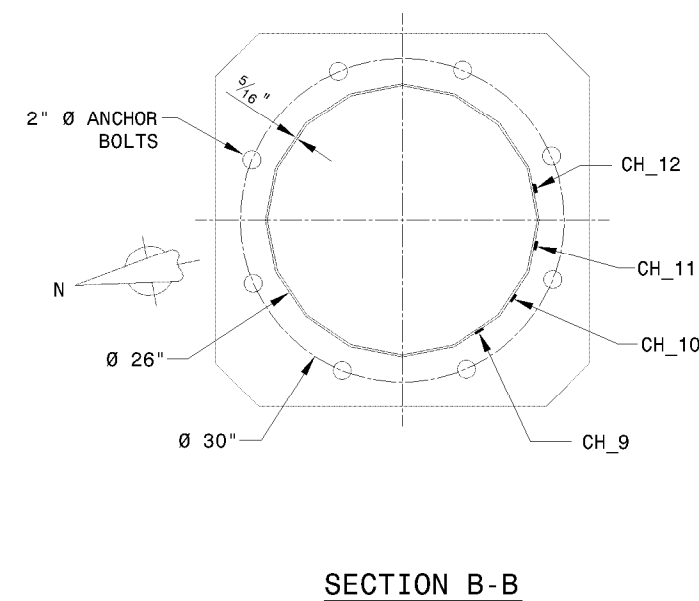
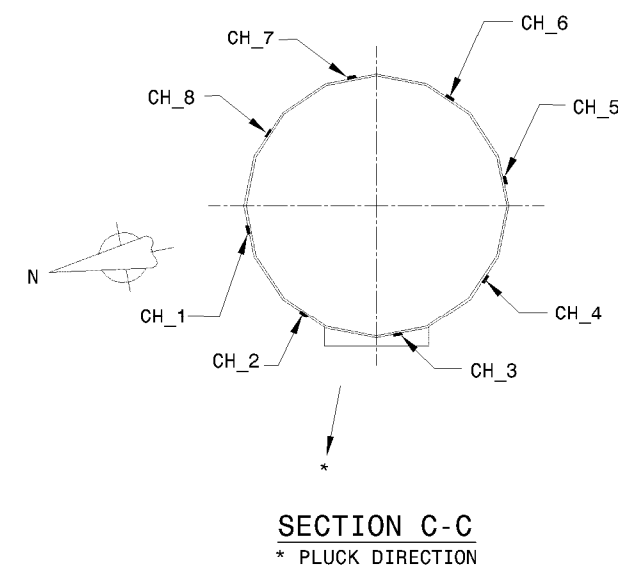
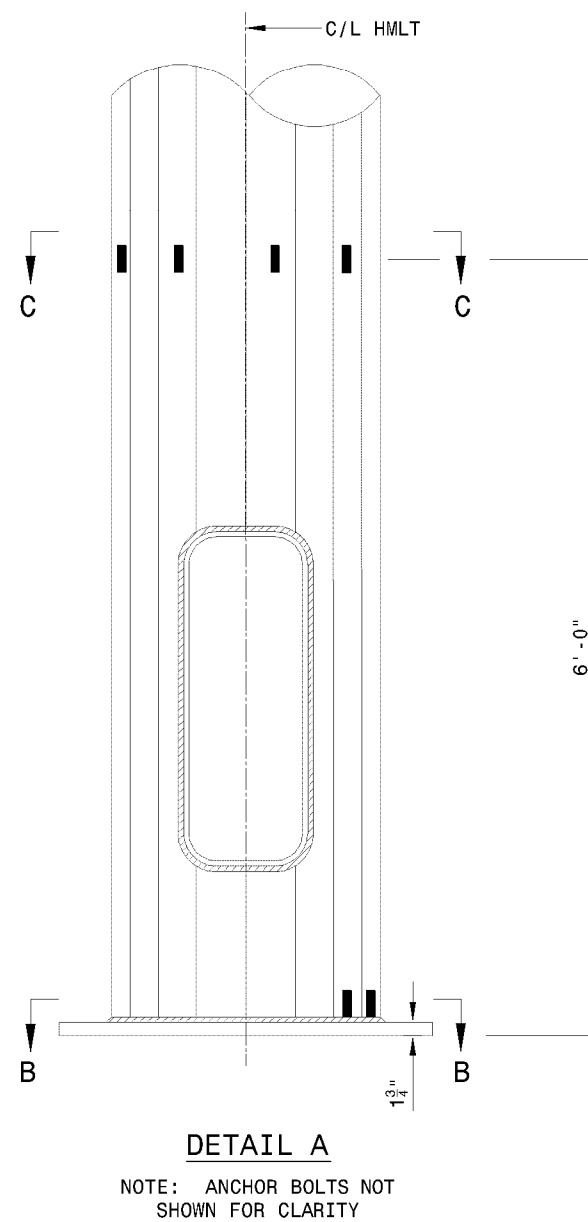
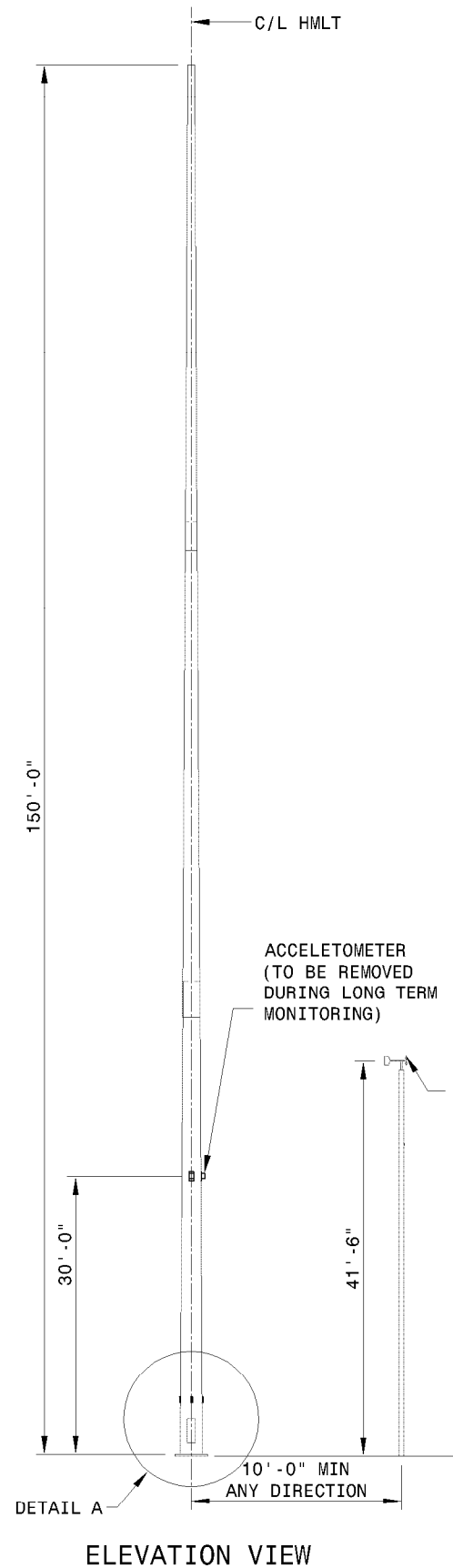

SHEET NOTES:

REVISIONS:
NO. DATE BY
DESCRIPTION

DESIGNED BY:
DRAWN BY:
CHECKED BY:
DATE:
PROJECT NO.:

SHEET TITLE:
**WYOMING, CRESTON
JUNCTION EAST
INSTRUMENTATION
PLAN**

SHEET NO.:
1 of 1

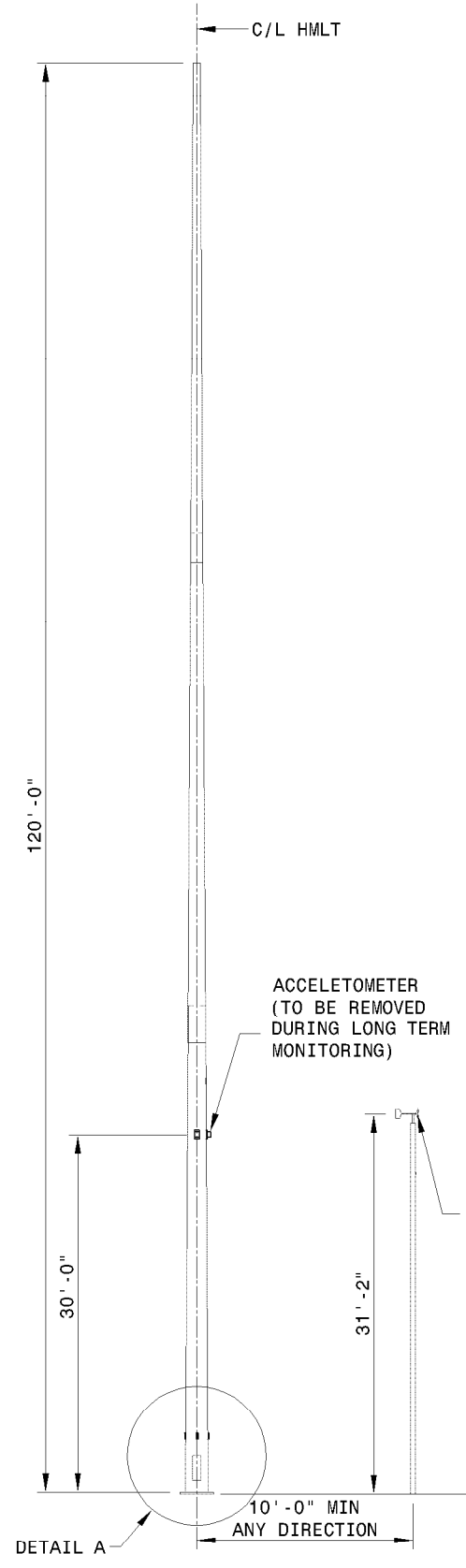

ELEVATION VIEW

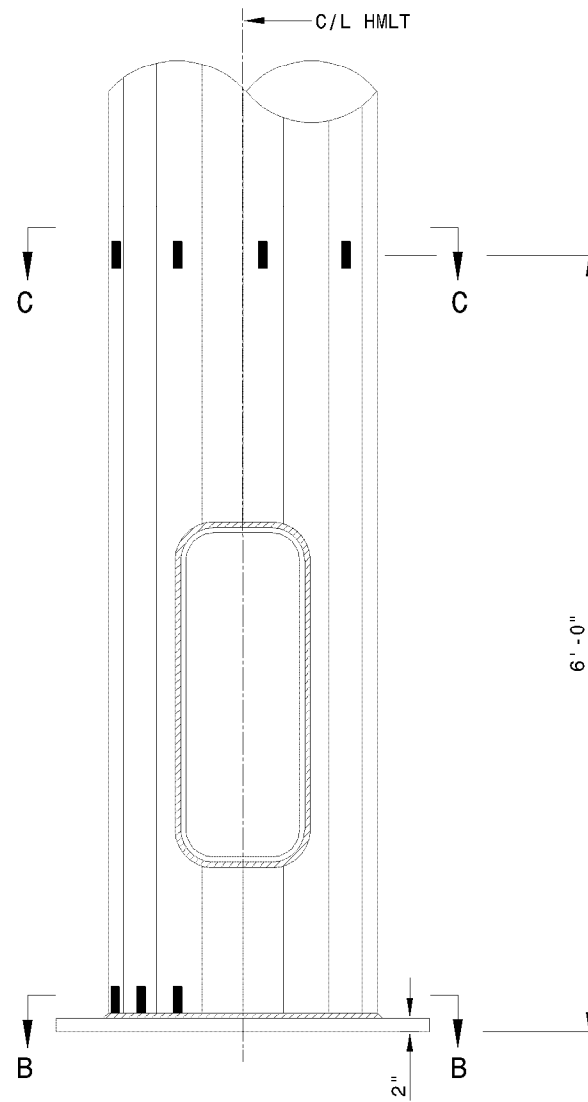

DETAIL A

NOTE: ANCHOR BOLTS NOT
SHOWN FOR CLARITY

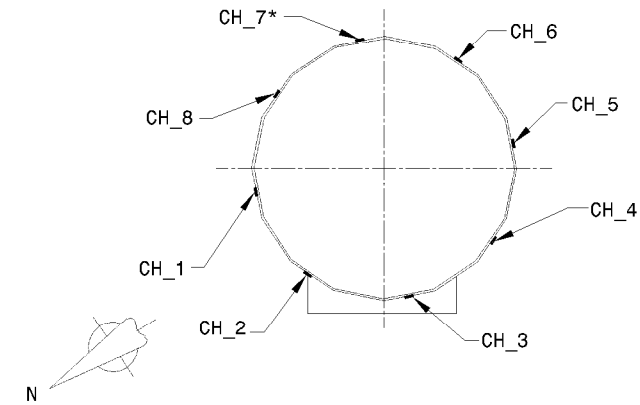

SECTION C-C
* PLUCKING DIRECTION

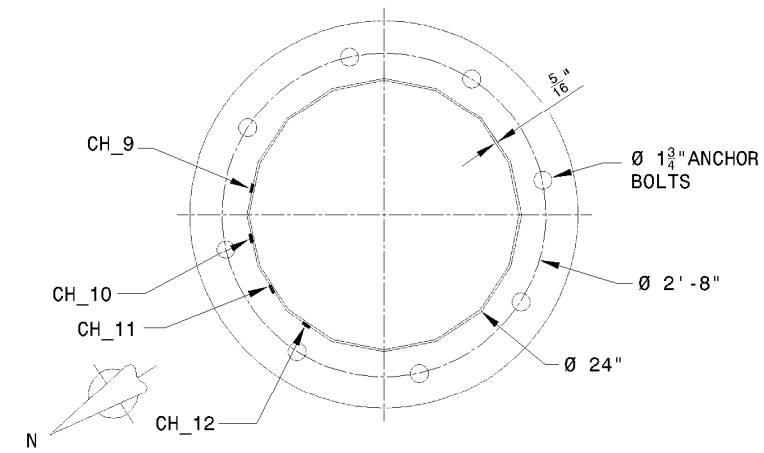

SECTION B-B

SHEET NOTES:

REVISIONS:

NO.	DATE	BY	DESCRIPTION

DESIGNED BY:
DRAWN BY:
CHECKED BY:
DATE:
PROJECT NO.:
SHEET TITLE:
**WYOMING, CRESTON
JUNCTION WEST
INSTRUMENTATION
PLAN**

